

The Mirage 5 was developed by Dassault Aviation from the proven Mirage III airframe. It had simplified avionics and, as a result, a lower production cost. The Mirage 5 was primarily designed for export.

The maiden flight took place in May 1967. Anxious to replace its Mirage III fleet, Israel quickly placed an order. However, it was cancelled following an embargo on arms sales to Israel imposed by the French government.

At that time, Belgium was making a decision regarding the replacement of its venerable F-84F and RF-84F. Apart from the Mirage 5, the Swedish SAAB Draken and the American Douglas Skyhawk were in line for contesting this order amounting to 106 aircraft in total. The choice eventually favoured the French machine, originally destined for Israel, after a cost reduction was negotiated including the use of American avionics as well as some economic compensations. Thus, apart from the first three pre-series aircraft built by Dassault, the entire order was assembled in Belgium by S.A.B.C.A / SONACA and FN.

Pre-series airframe MA 01 made its first flight on 6th March 1970. Renamed BA 01, it was delivered to the Belgian Air Force on 29th June of the same year. The two-seater version MD 01 and the reconnaissance version MR 01 followed and were respectively renamed BD 01 and BR 01. Initially, these three aircraft were overall natural metal but they were painted prior to joining their operational units. Of the one hundred and six aircraft built, sixty-three were BA, sixteen BD and twenty-seven BR.

The Squadrons began their re-equipment with the new machines from 1970. The 3rd Wing from Bierset was the first to receive its Mirages which went to the 1st Squadron (Mirage BA) as well as the 8th Squadron (Mirage BD). Next came the 2nd Wing based at Florennes with its 2nd Squadron (Mirage BA). Finally, in 1971, the 42nd RECCE Squadron, also based at Florennes, equipped with Mirage 5 BR.

But the end was programmed. In 1987, the 2nd Squadron abandoned its Mirages to take delivery of the F-16 and in 1989, it was the turn of the 1st Squadron. During that period, the 42nd Squadron moved to Bierset with its BR where it remained till the end. All Mirages still in service at that time with the 1st Squadron were transferred to the 8th Squadron where they continued their operational career until 1992 after a last "lap of honour" when they took part in the « Desert Storm » operation at the end of a career lasting more than twenty years.

When they entered service, all the Mirages received a Vietnam-type camouflage, made up of two shades of green and beige on top and very light grey underneath. Although the camouflage scheme was identical for all aircraft (BA, BR or BD), it could vary significantly from one aircraft to another. This scheme remained in service until 1981. At that time, all aircraft received an overall wrap-around camouflage.

It was intended to prolong the operational life of the Mirage 5 beyond the year 2000. The MIRSIP program (Mirage Safety Improvement Program) planned the modernisation of the aircraft electronics and of the cockpit. Unfortunally, for budgetary reasons, the Mirage 5 was modernised ... to be sold to the Chilean Air Force.

1 Squadron(*)	2 Squadron	8 Squadron
03 BA 03	01 and 02 BA 01 and BA 02	201 to 216 BD 01 to BD 16
05 to 10 BA 03 to BA 10	04 BA 04	
12 BA 12	11 BA 11	
15 BA 15	13 and 14 BA 13 and BA 14	
17 BA 17	16 BA 16	
19 BA 19	18 BA 18	
21 to 23 BA 21 to BA 23	20 BA 20	
25 BA 25	24 BA 24	
28 to 42 BA 28 to BA 42	26 and 27 BA 26 and BA 27	
44 to 49 BA 44 to BA 49	43 BA 43	
51 BA 51	50 BA 50	
55 BA 55	52 and 53 BA 52 and BA 53	
56 BA 56	57 and 58 BA 57 and BA 58	
59 to 63 BA 59 to BA 63		
		42 Squadron
		301 to 327 BR 01 to BR 27

(*) Until 1989

Note: The above table is given by way of information and does not take into account aircraft withdrawn from service for various reasons (accident or other).

Sources :

Belgian Military Aviation 1945-1977 – Paul A. Jackson - Midland Counties Publications.

History of the Belgian Air Force (1910 – 1990) – John Pacco – JP Publications.

La Force Aérienne – Lannoo.

Le Mirage 5 fut développé par Dassault Aviation sur base de la cellule éprouvée du Mirage III. Il avait une avionique simplifiée et donc un coût de reviens moins élevé. Le Mirage 5 était avant tout destiné à l'exportation.

Le premier vol eut lieu en mai 1967. Cherchant un successeur à son Mirage IIIC, Israël passa rapidement une commande. Toutefois, celle-ci fut annulée suite à un embargo décrété par le Gouvernement Français de l'époque sur les ventes d'armes à Israël.

A ce moment, la Belgique devait prendre une décision quant au remplacement de ses vénérables F-84F et RF-84F. Outre le Mirage 5, le SAAB Draken suédois et le Douglas Skyhawk américain étaient en lice pour l'obtention de ce marché portant sur une commande totale de cent six appareils. Le choix se porta finalement sur l'avion français, originellement destiné à Israël, après négociations sur une réduction des coûts, l'utilisation d'une avionique américaine ainsi que des compensations économiques. C'est ainsi qu'à l'exception des trois premiers avions de pré-série construits chez Dassault, l'entièreté de la commande fut assemblée en Belgique par les sociétés S.A.B.C.A / SONACA et FN.

L'appareil de pré-série MA 01 fit son premier vol le 06 mars 1970. Redésigné BA 01, il fut livré à la Force Aérienne Belge le 29 juin de la même année. Les versions biplaces MD 01 et reconnaissance MR 01 suivirent et furent respectivement redésignées BD 01 et BR 01. Initialement, ces trois appareils étaient entièrement métal naturel mais furent peints avant leur entrée en unité. Sur les cent six appareils construits, il y avait soixante-trois BA, seize BD et vingt-sept BR.

Les Escadrilles commencèrent à être dotées de leur nouveau matériel à partir de 1970. Le 3^e Wing de Bierset perçut le premier ses Mirage qui allèrent équiper la 1^e Escadrille (Mirage BA) ainsi que la 8^e Escadrille (Mirage BD). Vint ensuite le 2^e Wing stationné à Florennes avec la 2^e Escadrille (Mirage BA). Finalement, en 1971, la 42^e Escadrille RECCE, également établie à Florennes, passa sur Mirage 5 BR.

Mais la fin était programmée. En 1987, la 2^e escadrille laissa ses Mirage pour passer sur F-16 et en 1989, ce fut le tour de la 1^e Escadrille. Pendant ce temps, la 42^e Escadrille rejoignait la base de Bierset avec ses BR où elle demeura jusqu'à la fin. Tous les Mirage alors encore en service à la 1^e Escadrille furent versés à la 8^e Escadrille où ils poursuivirent leur carrière opérationnelle jusqu'en 1992 après un dernier baroud d'honneur avec leur participation à l'opération « Desert Storm » et plus de vingt ans de carrière.

A leur entrée en service, tous les Mirage reçurent un camouflage type Vietnam, composé de deux tons de vert et beige sur le dessus, gris très clair en dessous. Bien que le schéma de camouflage fusse identique pour tous les appareils (BA, BR ou BD), celui-ci pouvait varier sensiblement d'un avion à l'autre. Ce schéma resta en service jusqu'en 1981. Tous les appareils furent alors entièrement camouflés dessus et dessous.

Il était prévu que la vie opérationnelle des Mirage 5 soit prolongée pour servir au-delà de l'an 2000. Le programme MIRSIP (Mirage Safety Improvement Program) portait en effet sur une modernisation de la partie électronique de l'avion ainsi que du cockpit. Malheureusement, pour des raisons budgétaires, les Mirage 5 furent bien modernisés...mais pour être revendus au Chili.

1e Escadrille(*)	2e Escadrille	8e Escadrille
03 BA 03	01 et 02 BA 01 et BA 02	201 à 216 BD 01 à BD 16
05 à 10 BA 03 à BA 10	04 BA 04	
12 BA 12	11 BA 11	
15 BA 15	13 et 14 BA 13 et BA 14	
17 BA 17	16 BA 16	
19 BA 19	18 BA 18	
21 à 23 BA 21 à BA 23	20 BA 20	
25 BA 25	24 BA 24	
28 à 42 BA 28 à BA 42	26 et 27 BA 26 et BA 27	
44 à 49 BA 44 à BA 49	43 BA 43	
51 BA 51	50 BA 50	
55 BA 55	52 et 53 BA 52 et BA 53	
56 BA 56	57 et 58 BA 57 et BA 58	
59 à 63 BA 59 à BA 63		
		42e Escadrille
		301 à 327 BR 01 à BR 27

(*) Jusqu'en 1989

NOTE : Le tableau ci-dessus est fourni à titre indicatif et ne tient pas compte des avions retirés du service à la suite de différentes causes (accident ou autre)

Sources :

- Belgian Military Aviation 1945-1977 – Paul A. Jackson - Midland Counties Publications.
- History of the Belgian Air Force (1910 – 1990) – John Pacco – JP Publications.
- La Force Aérienne – Lannoo.

1 Wings

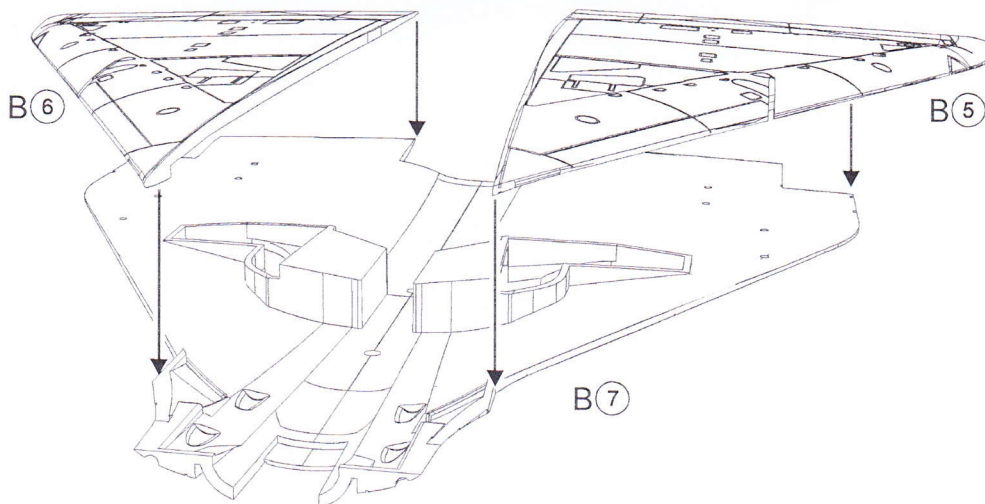

2 Rear fuselage

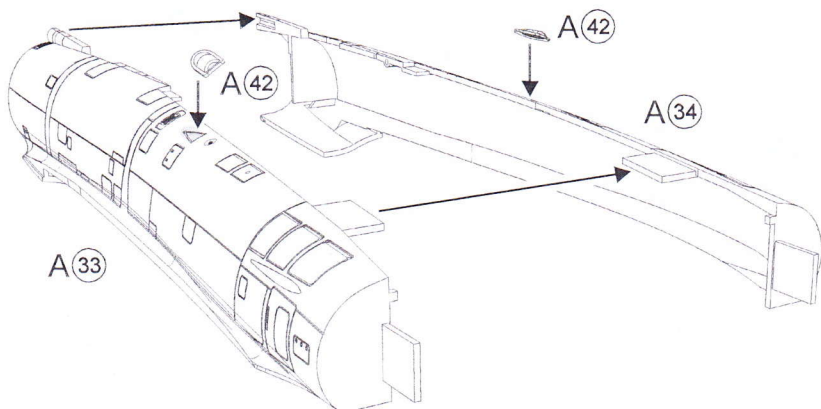

3 Exhaust

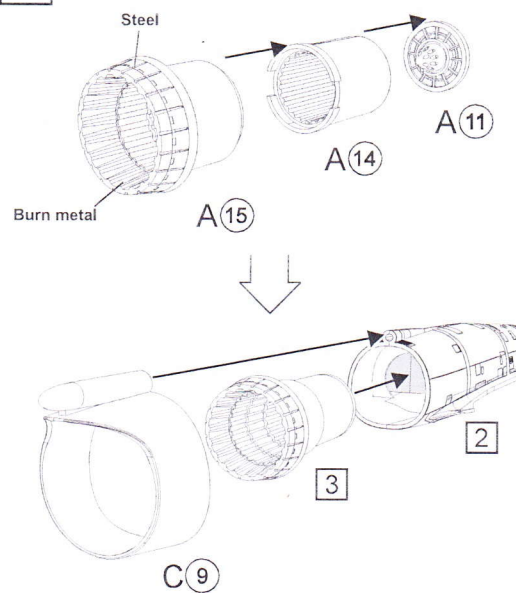

4

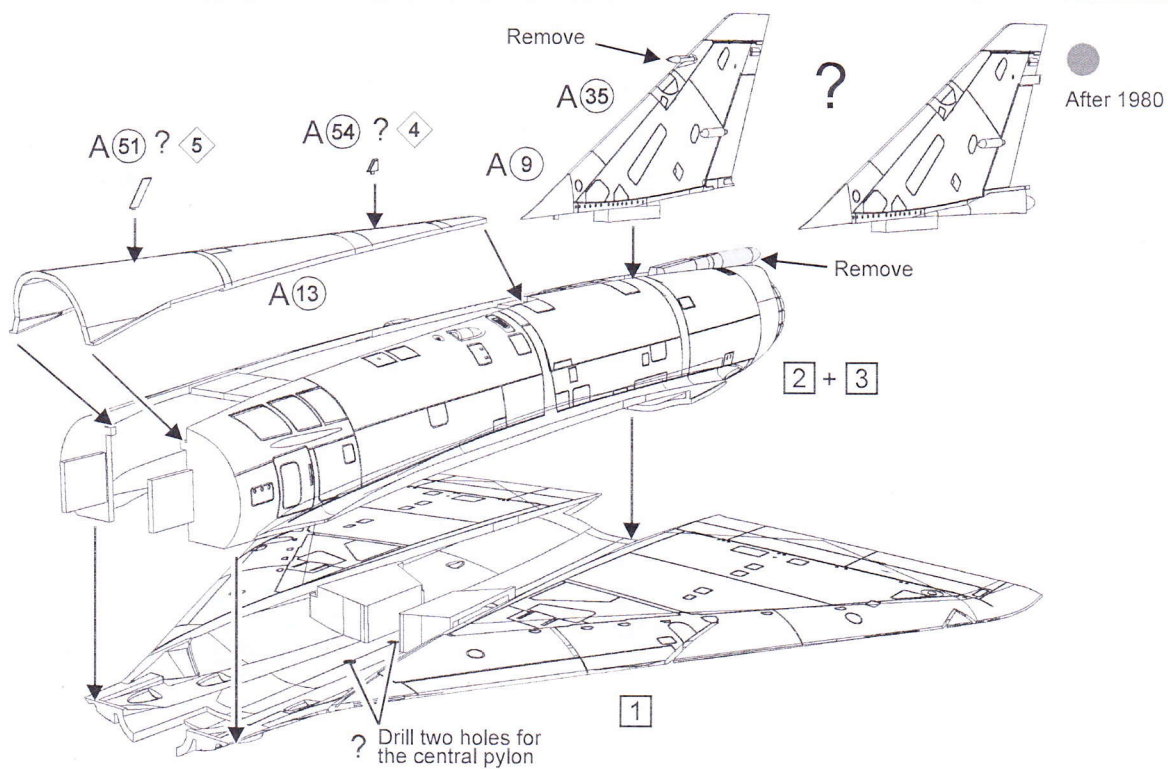

5 Seats

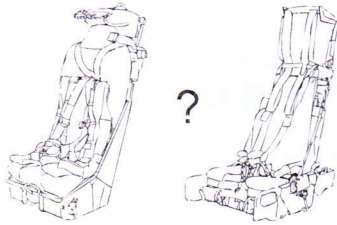

MB Mk4

MB Mk10
Equipped aircraft
late in the 80's

Seat: Matt Black
Cushions: Tan or Kaki Brown
Seat belts: Blue
Handles: Black/Yellow striped

6 Front fuselage

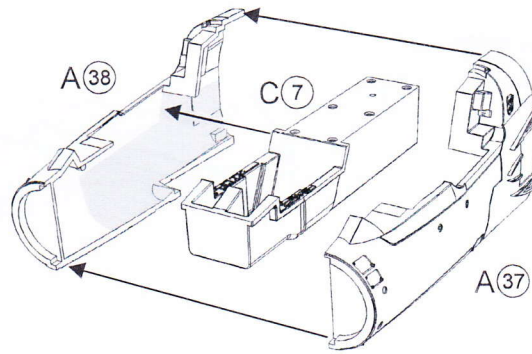

Inside cockpit: Matt Black

7 Cockpit

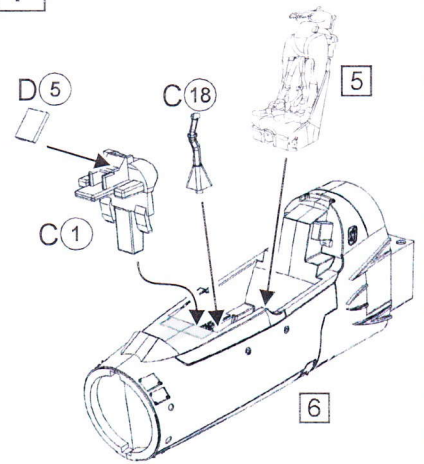

Inside cockpit: Matt Black

8 Noses

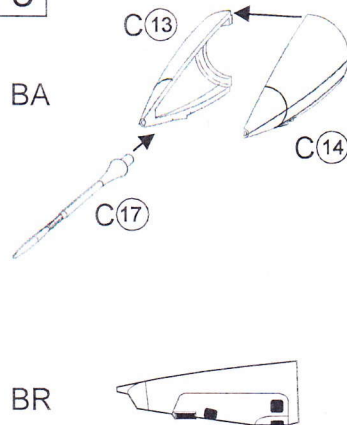

9 Fuselage setting

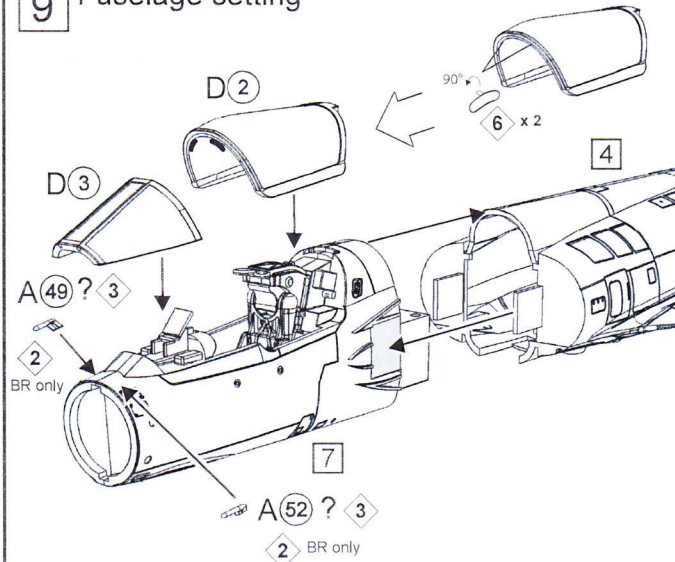

10 Nose wheel

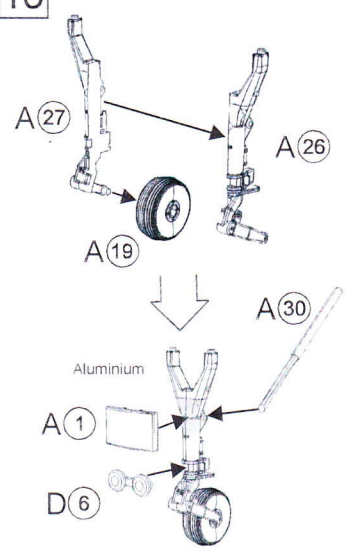

11 Air intakes

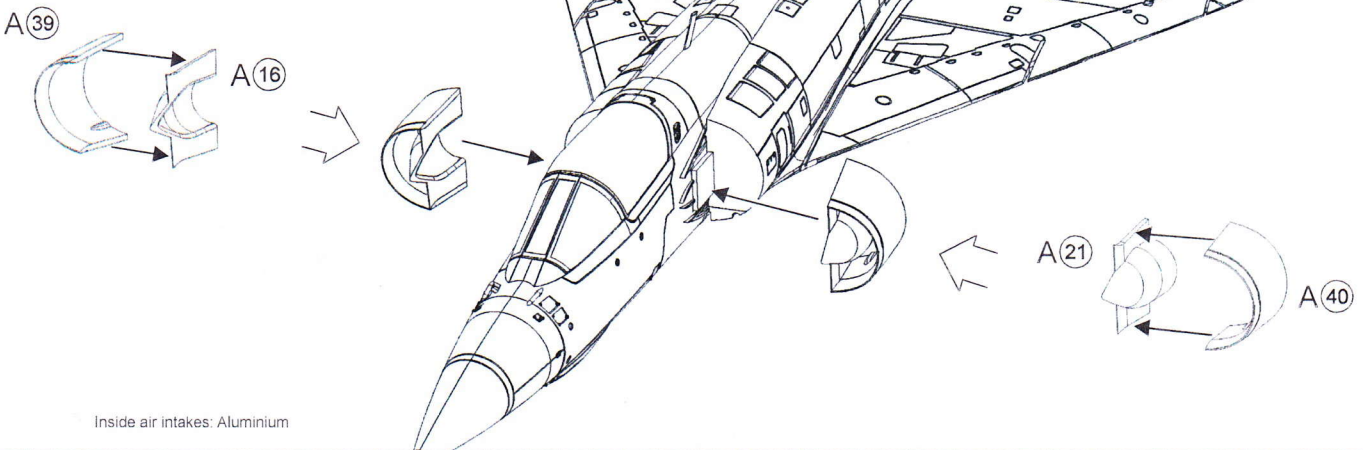

Inside air intakes: Aluminium

12 Main landing gear - Right

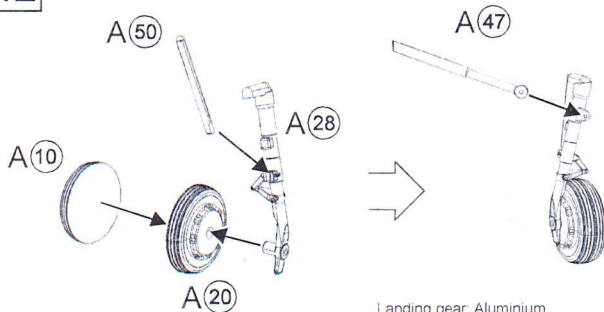

Landing gear: Aluminium

13 Main landing gear - Left

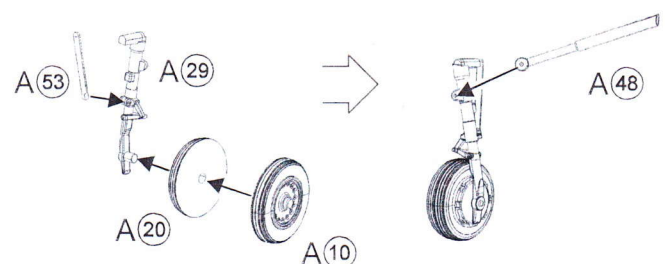

14

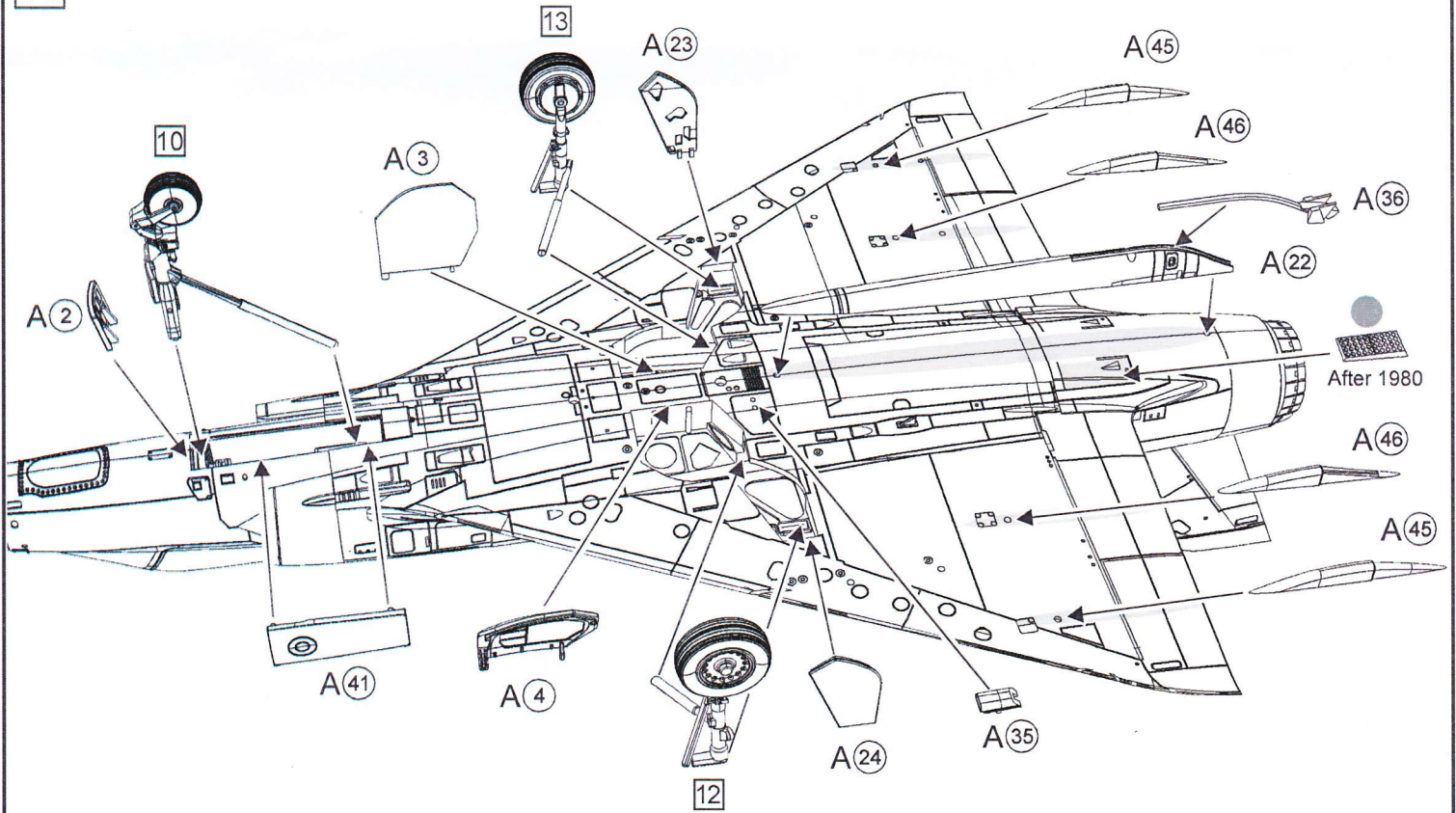

Landing gears doors and wheels bays : Aluminium

15 External fuel tanks

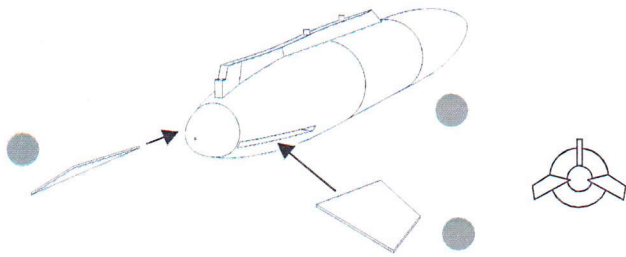

1700 L

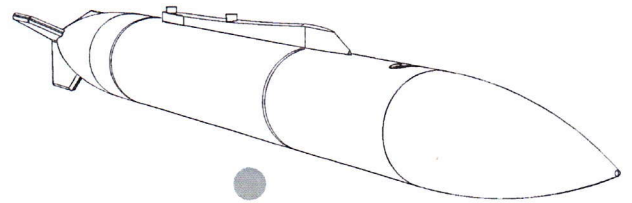

Supersonic 500 L

16 Tanks positioning

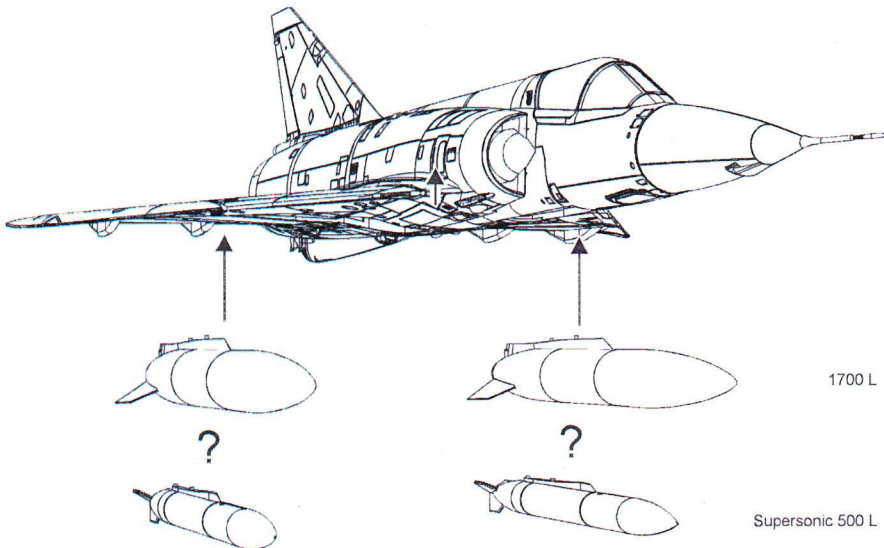

1700 L

Supersonic 500 L

17 Ladder

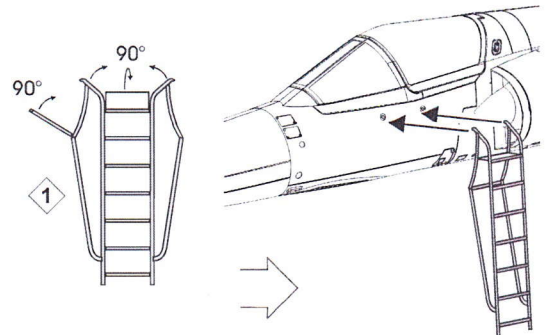

Rue A. Bodson 38 - B6280 Gerpinnes (Belgium)
 Tel / Fax : ++32 (0)71.50.44.39
 Email : pjproduction@pjproduction.net
 Web site : www.pjproduction.net

Mirage V BA of the No 8 Squadron based at Bierset and temporarily detached at Diyarbakir (Turkey) during the operation "Desert Storm".
Vietnam type camouflage after 1980 (Tan/Dark Green/Light Green on all surfaces).

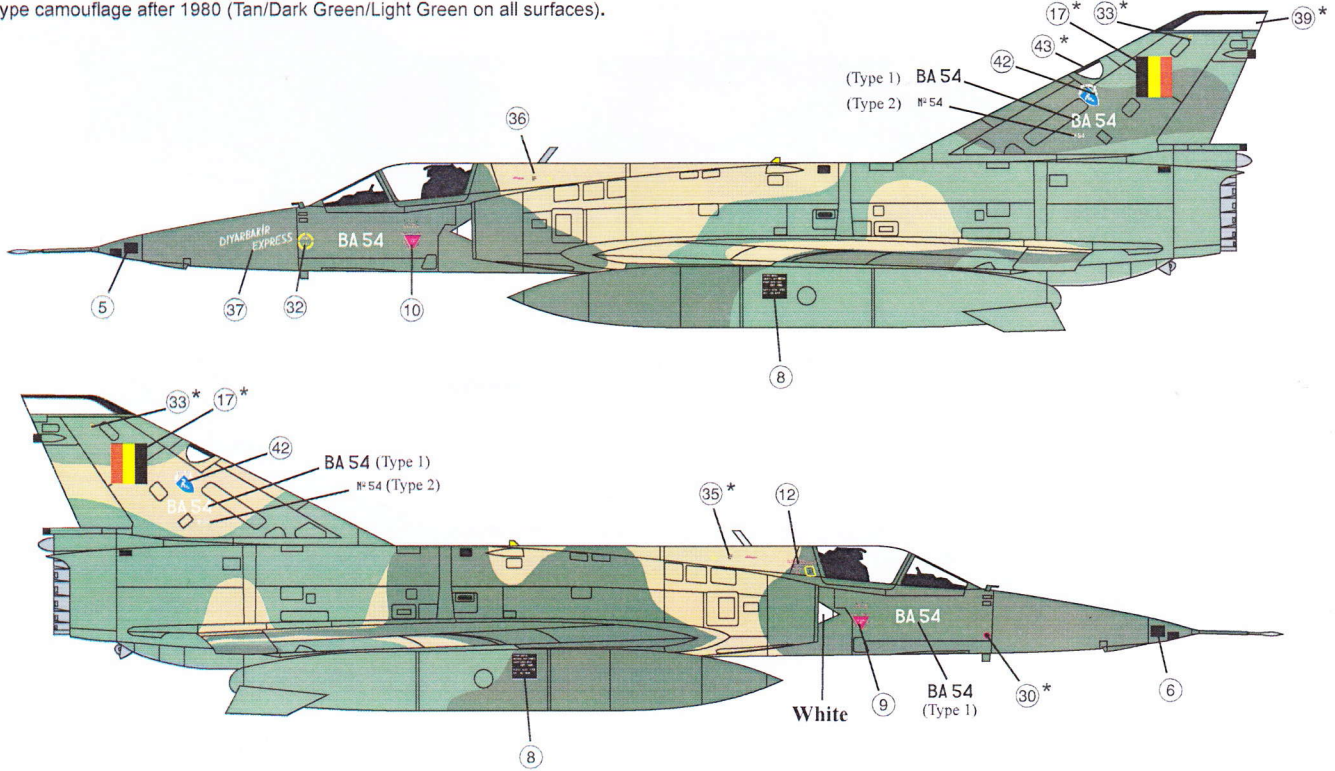

PAINT CONVERSION

	Humbrol	Gunze	Tamiya	Fed. Std
Dark Green	116	H309	XF27/61	FS34064
Medium Green	117	H73	XF61/65	FS34102
Tan	118	H310	XF52	FS30219
Light Grey	147	H62	XF19	FS36622

Note for decals setting:

L / R = Left and Right side

○* = Common to all versions

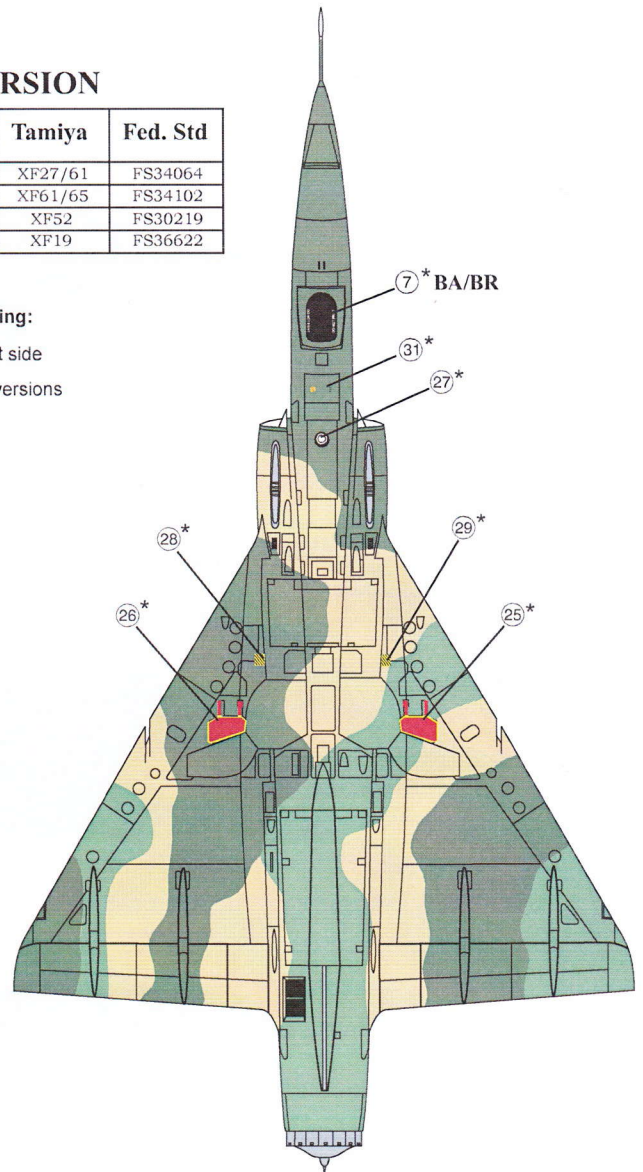
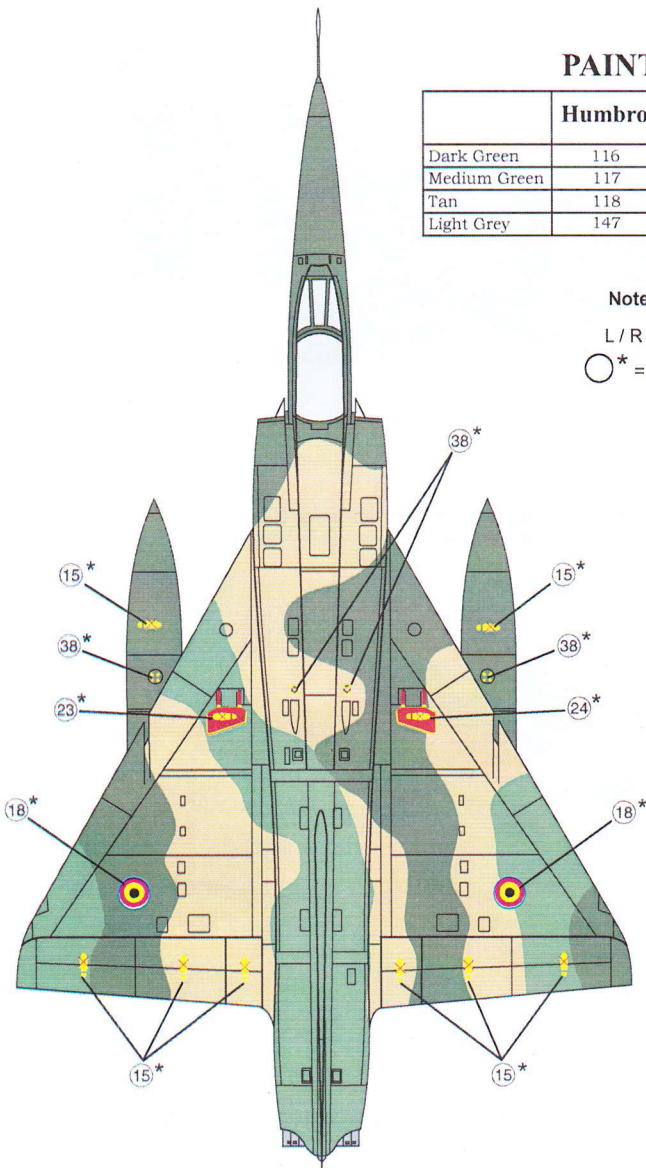

Mirage V BA of the No 2 Wing, No 2 Squadron, Belgian AF, Florennes 1980.
 Vietnam type camouflage before 1981 (Tan/Dark Green/Light Green uppersurfaces, Light Grey undersurfaces).

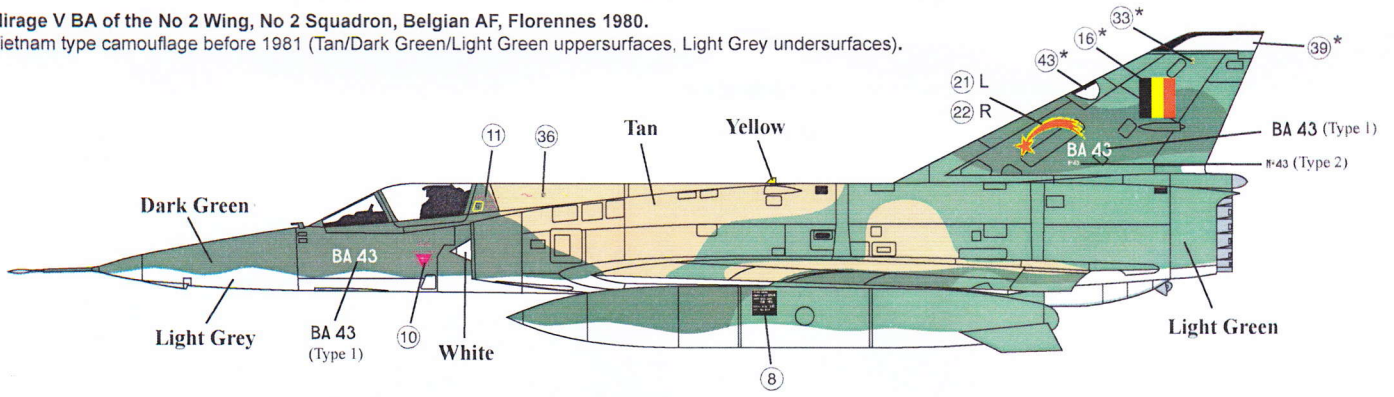

Mirage V BA of the No 1 Wing, No 8 Squadron, Belgian AF, Bierset before 1989.
 Vietnam type camouflage before 1981 (Tan/Dark Green/Light Green uppersurfaces, Light Grey undersurfaces).

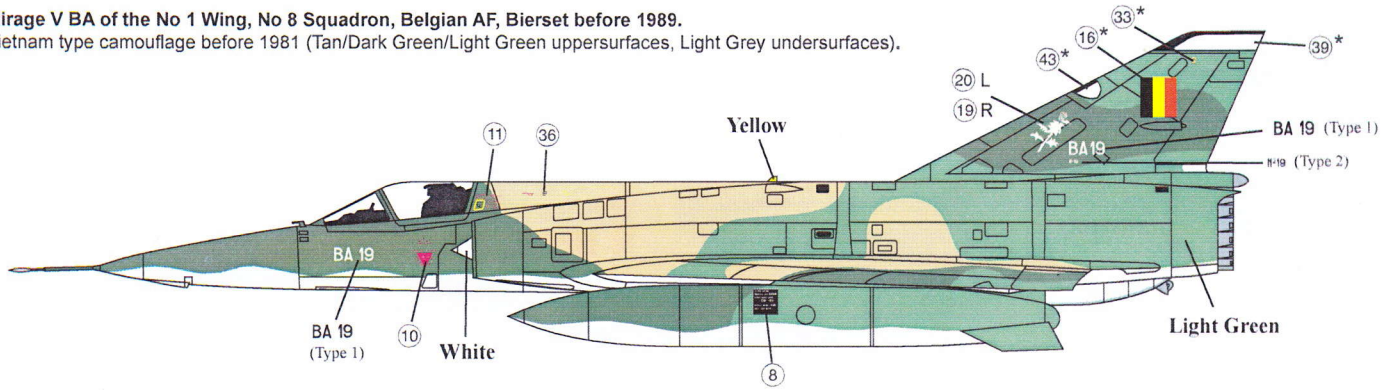

Mirage V BR of the No 42 Squadron, Florennes 1978.
 Vietnam type camouflage before 1981 (Tan/Dark Green/Light Green uppersurfaces, Light Grey undersurfaces).

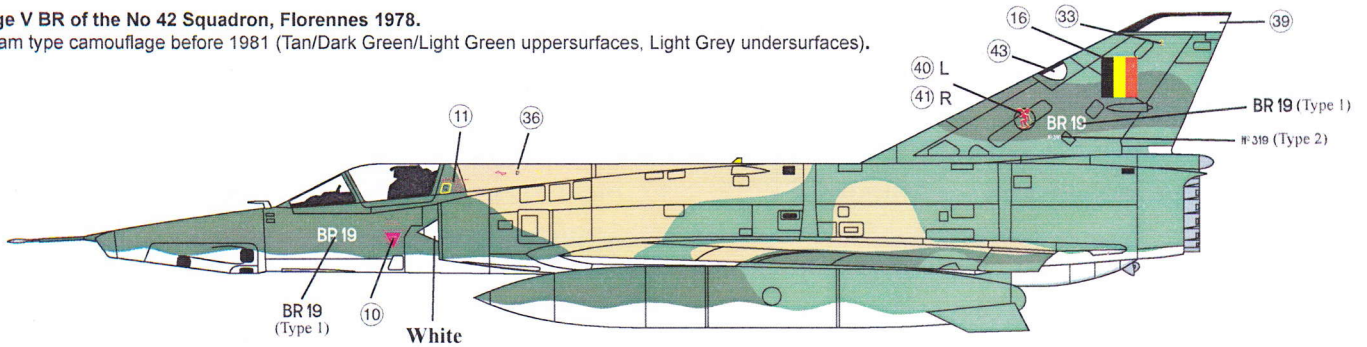

Mirage V BR of the No 42 Squadron, Bierset late in the 80's.
 Vietnam type camouflage on all surfaces.

