

SW 72127

scale 1/72



U-125A JASDF

Special anniversary versions



The U-125A is based on a mid-sized business jet originally developed by de Havilland in 1961 as the DH 125 Jet Dragon. The aircraft was a low wing mono-plane design with slightly swept wings and a turbojet engine mounted to each side of the rear fuselage. The first prototype flew on 13 August 1962 and the second prototype fitted out more like a production model flew on 12 December 1962. Produced by Hawker Siddeley who already owned de Havilland, as the HS. 125, the production aircraft had a longer fuselage and greater wingspan and first flew on 12 February 1963. The 125 was continually upgraded with new powerplants, cockpit systems and airframe modifications as technology improved. It also underwent a continual change of ownership over time. During the 1990's, Japan was the first country to specify the

U-125A, a Hawker 800 based variant extensively modified for maritime Search And Rescue duties, built by Raytheon who now owned 125 production. They have been operational since 1995. The aircraft features large observation windows on both sides of the fuselage, a Toshiba 360 degree belly mounted radar system, Melco thermal imaging equipment, a flare and marker-buoy dispenser, and it is also able to drop inflatable liferafts, large enough to accommodate crew and passengers from larger ships. These can be accessed and released from the pressurised cabin and are dropped through the main wheelwells with the gear extended. The airframe uses enhanced anti-corrosion measures to protect it from the harsh maritime environment. Japan has been supplied with 27 U-125A aircraft and currently operates 25. In 1996, a U-125A located a foundering Russian cargo ship in the Sea of Japan and is credited with saving 22 lives of the crew.

JASDF aircraft usually have unit markings on the tail, but the U-125A have their markings on the fuselage, with their assigned base underneath.

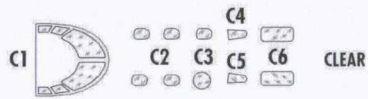
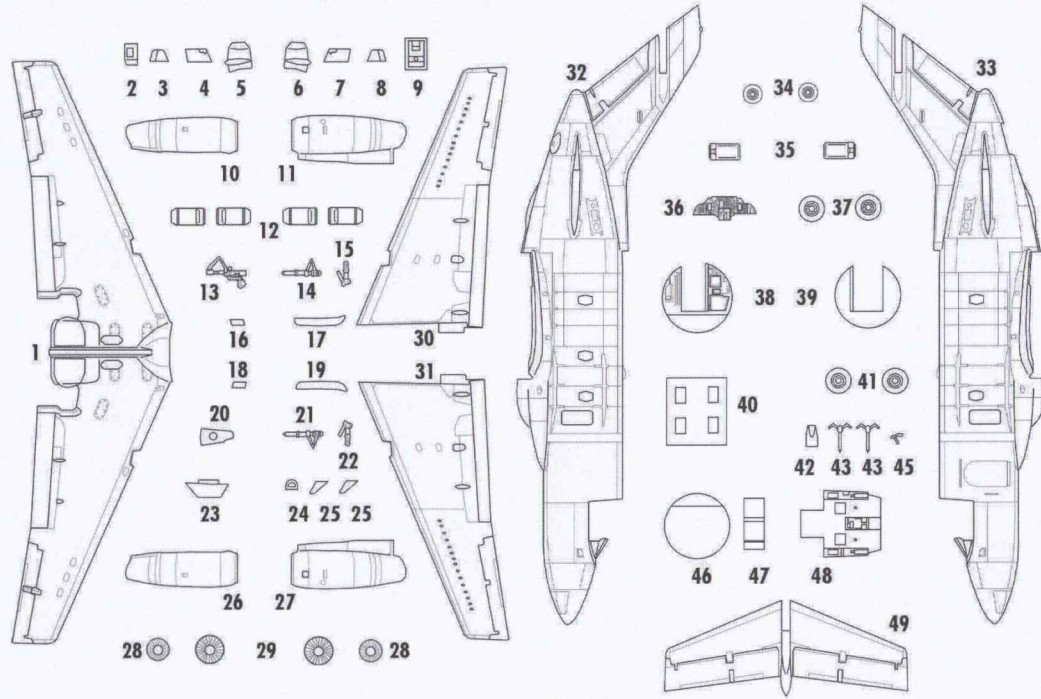
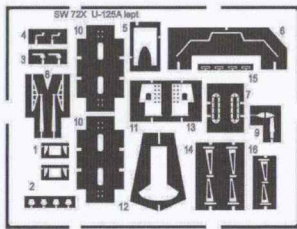
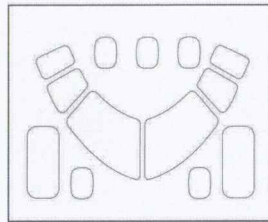

PHOTO-ETCHED



MASK



BARVA/COLOR

- A Světlá krémová / Light Creamy
- B Černá/Black
- C Stříbrná/Silver
- D Hliníková / Aluminium
- E Chromová / Chrome
- F Světle šedá / Light Grey
- G Tmavá šedá / Dark Grey
- H Kůže / Leather
- I Kovová / Gun metal
- J Barva pneu / Tyres Black
- K Střední šedá / Medium Grey
- L Přírodní kov / Natural metal

Preparatory procedures

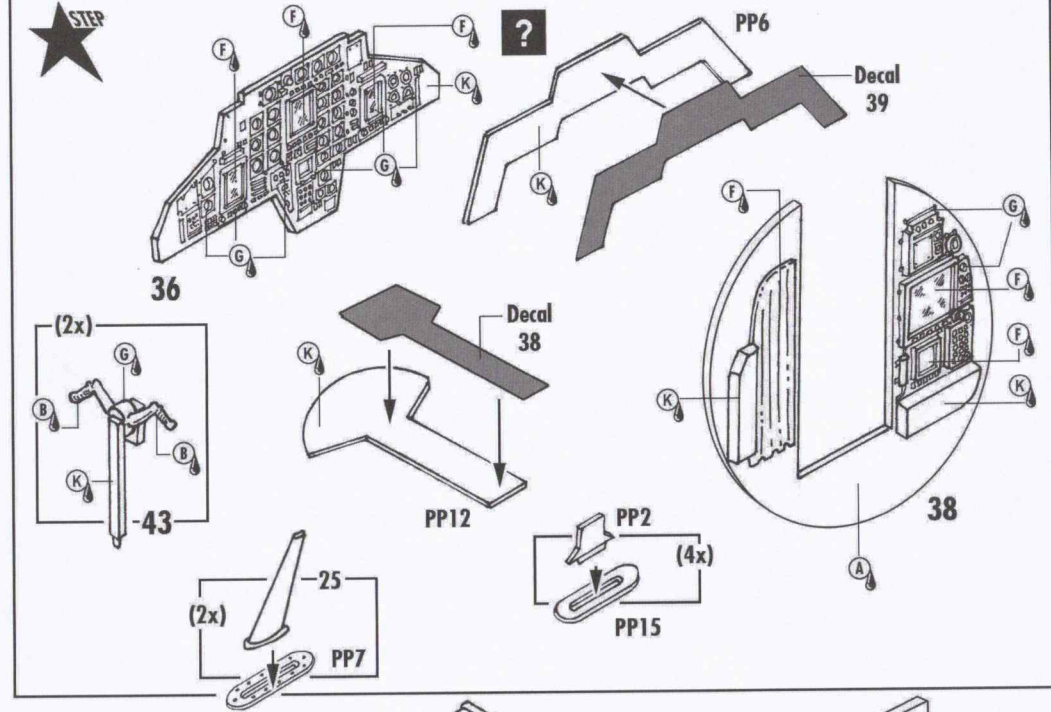

STEP

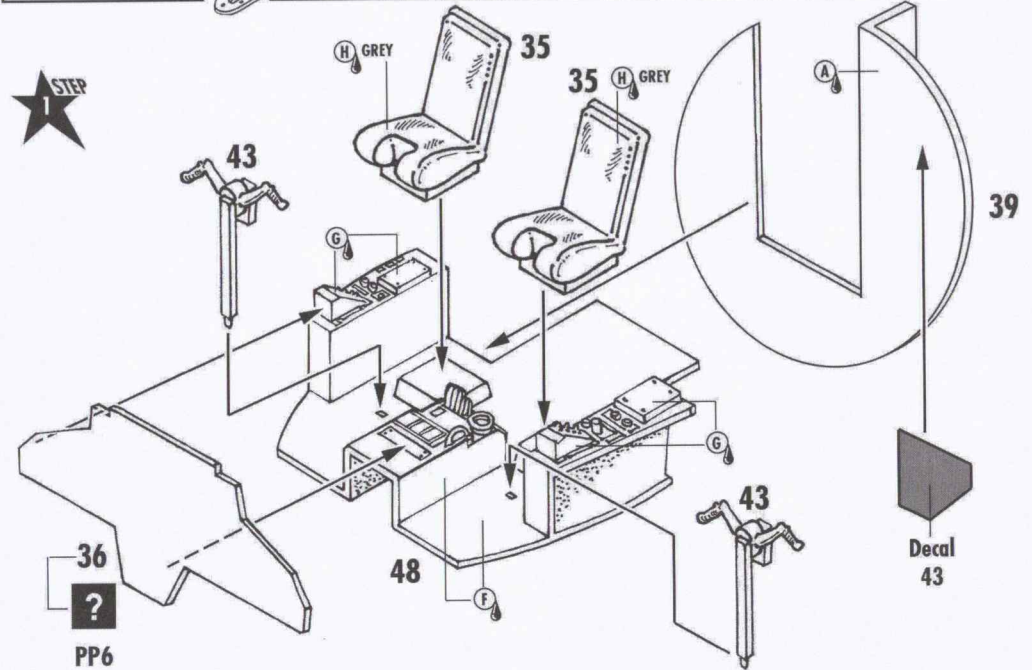

STEP 2

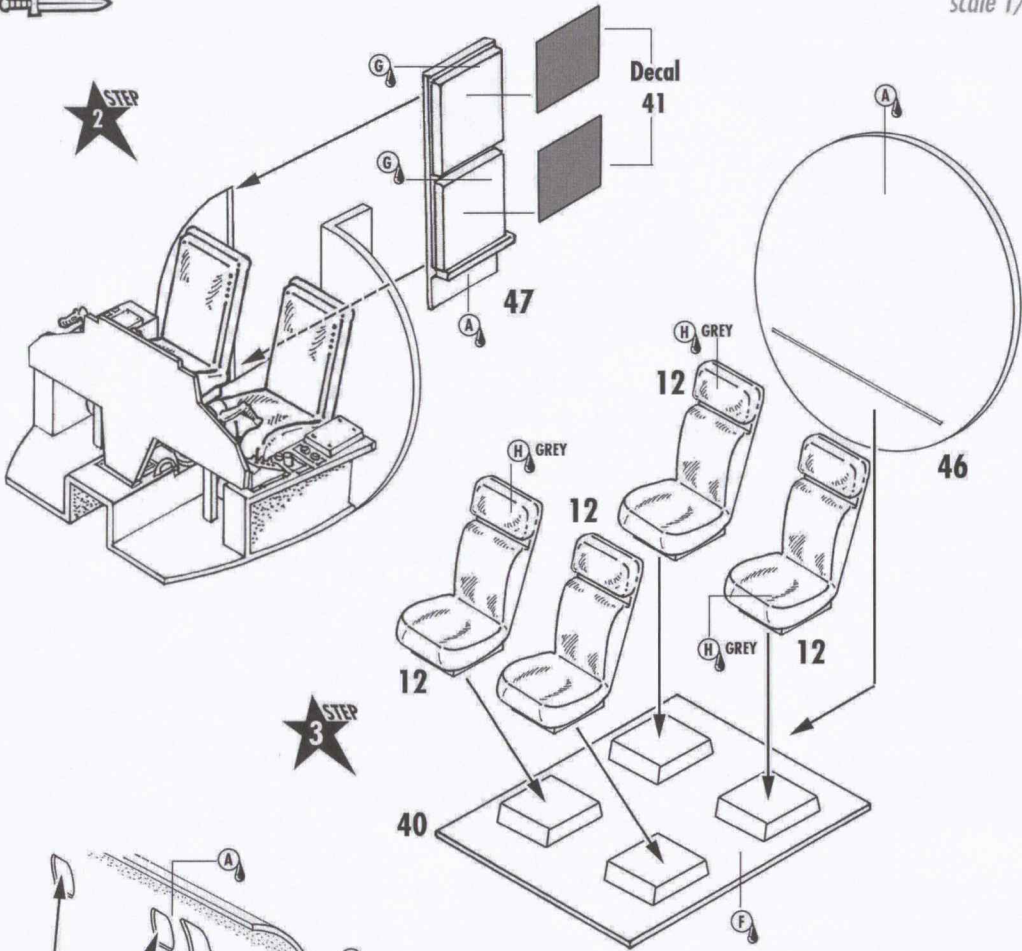

STEP 3

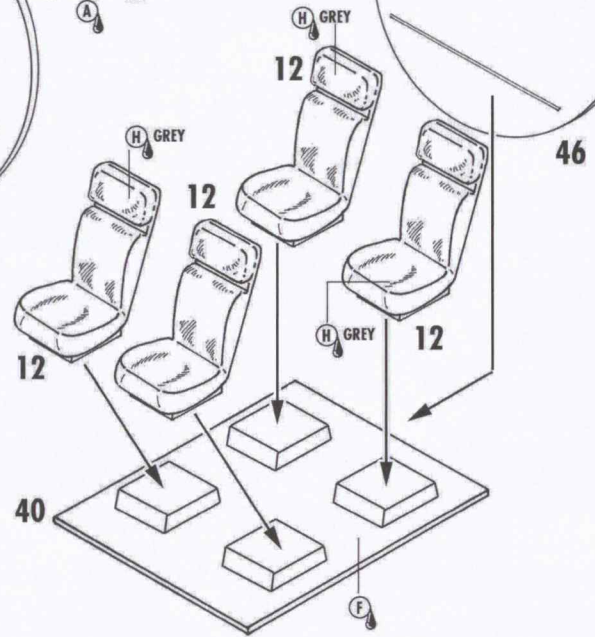

STEP 4

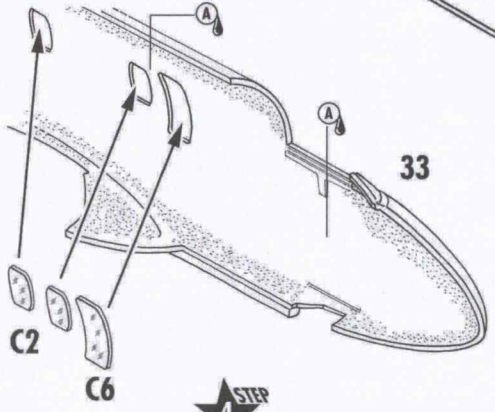

STEP 5

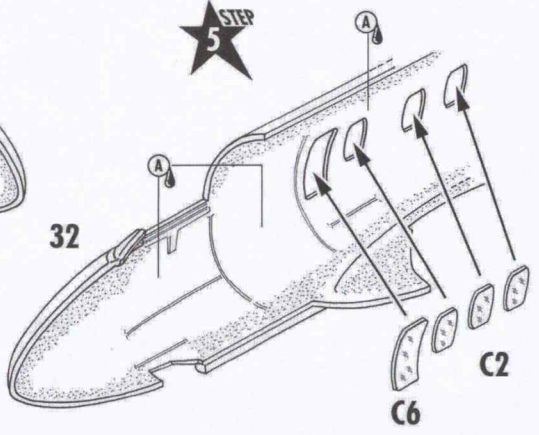

STEP 6

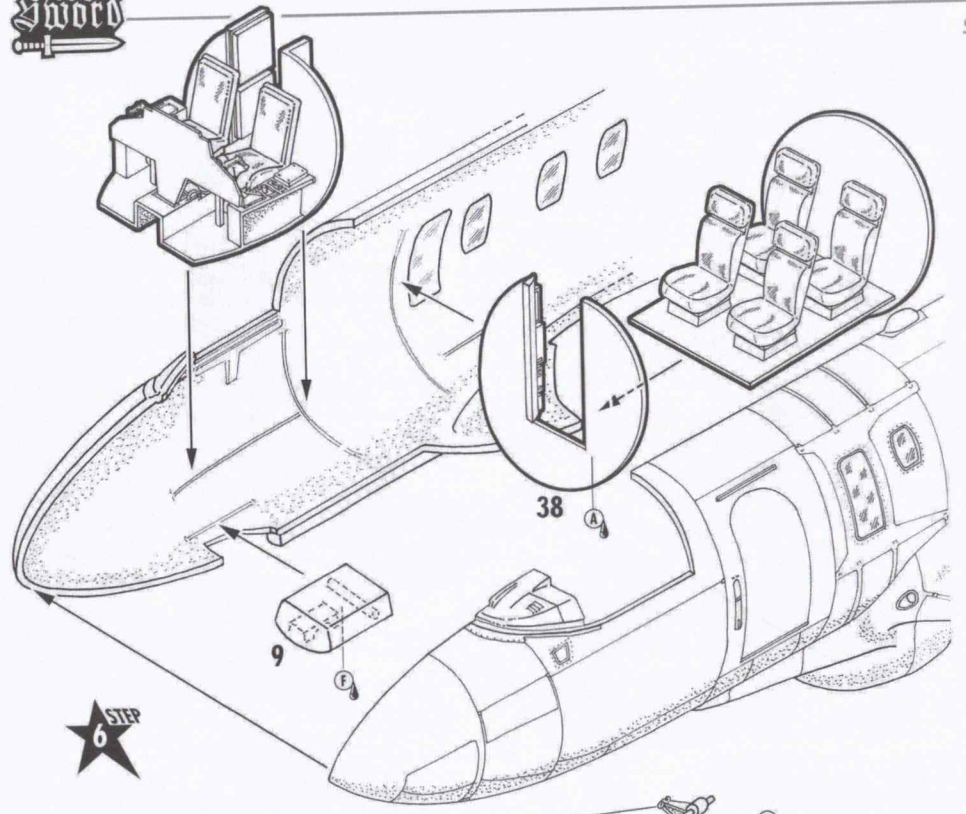

STEP 7

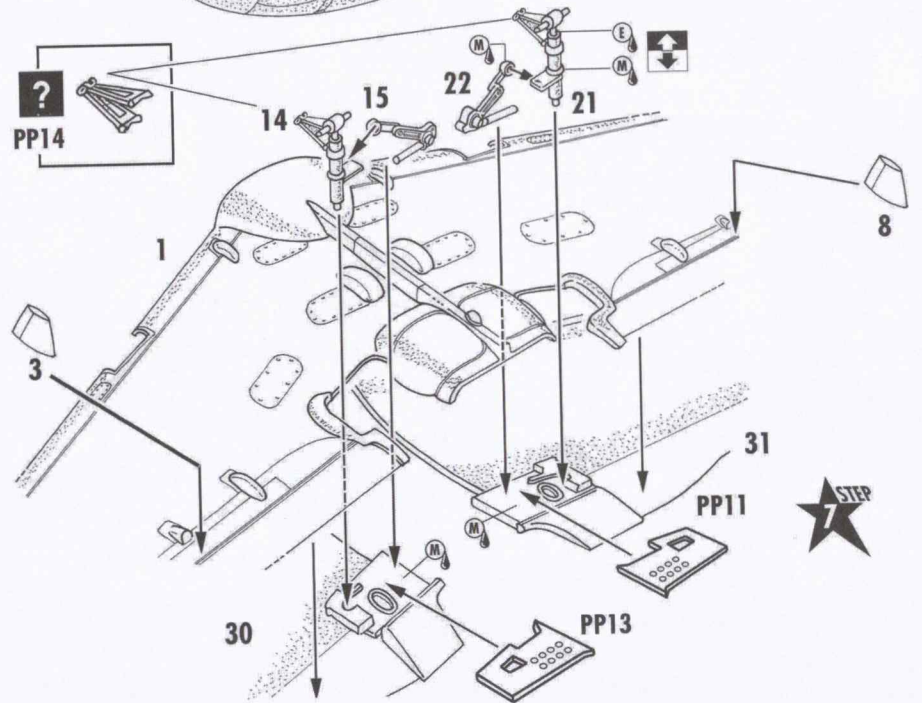

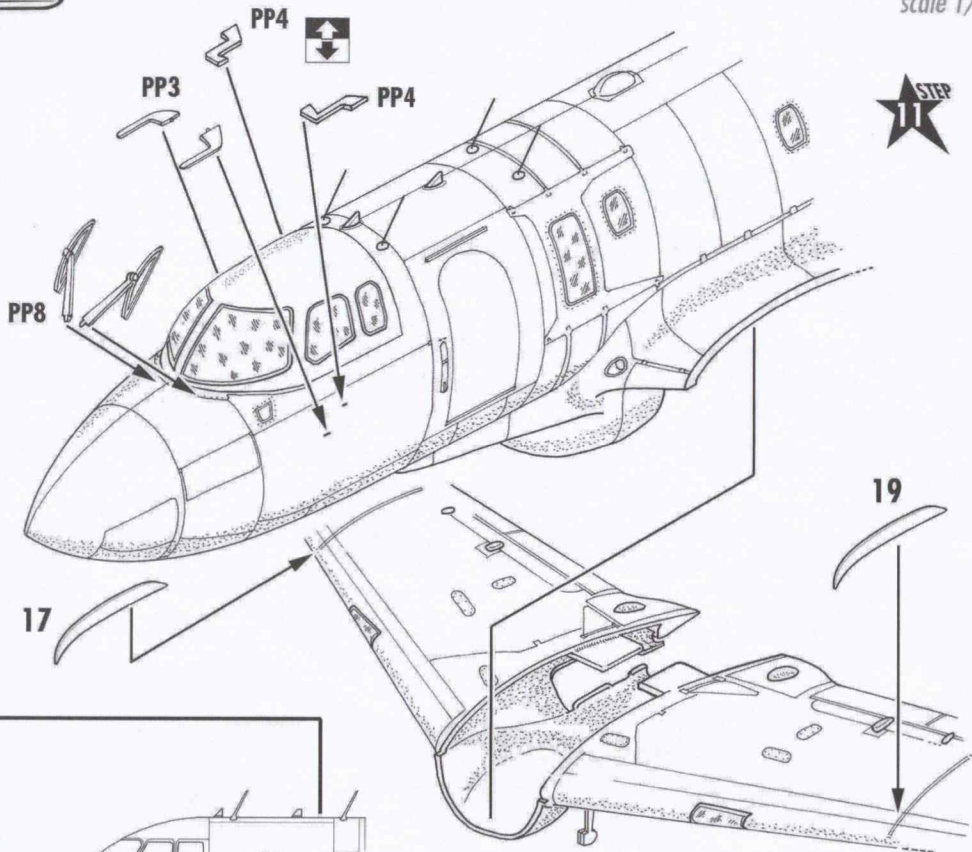

STEP 11

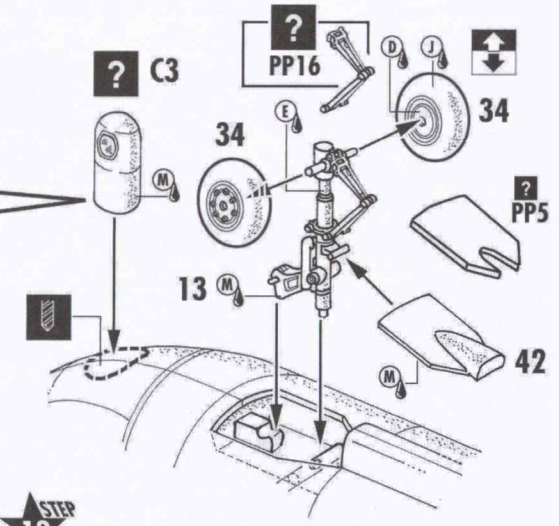
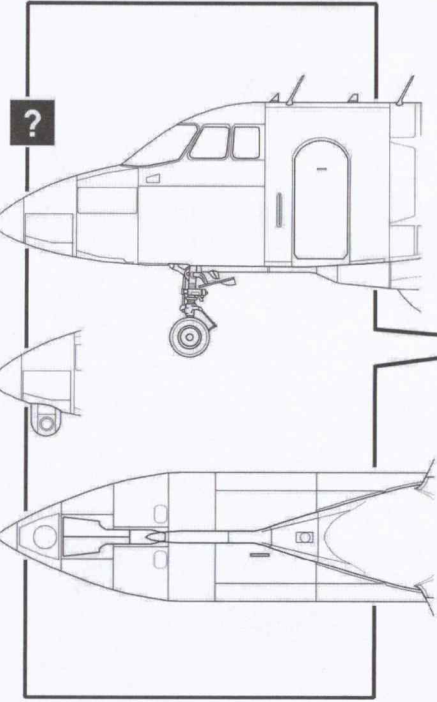

STEP 12

STEP 8

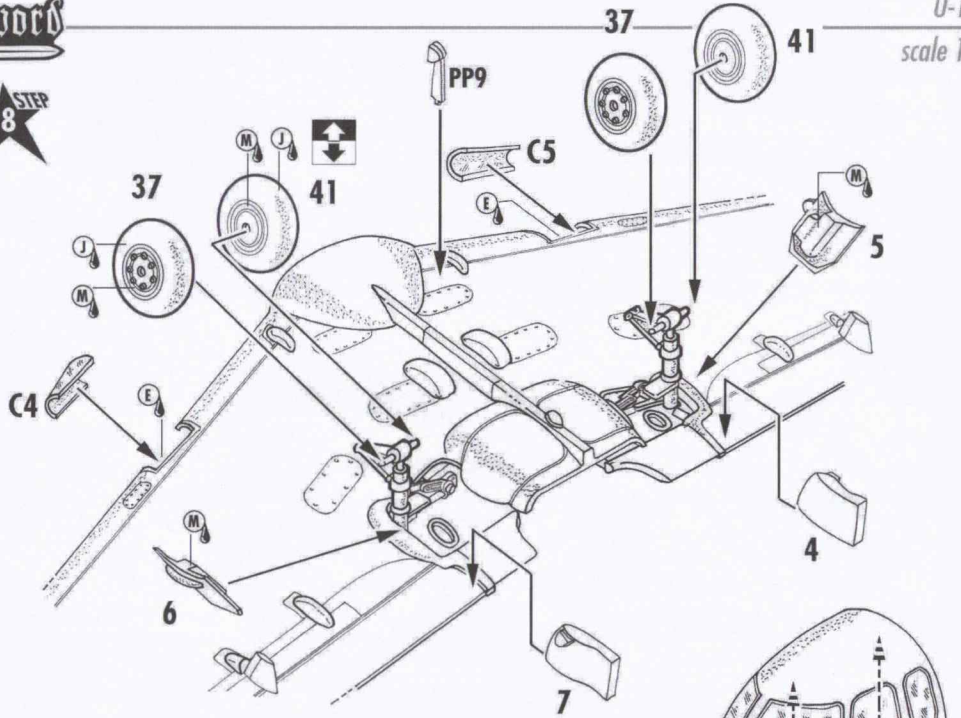

STEP 9

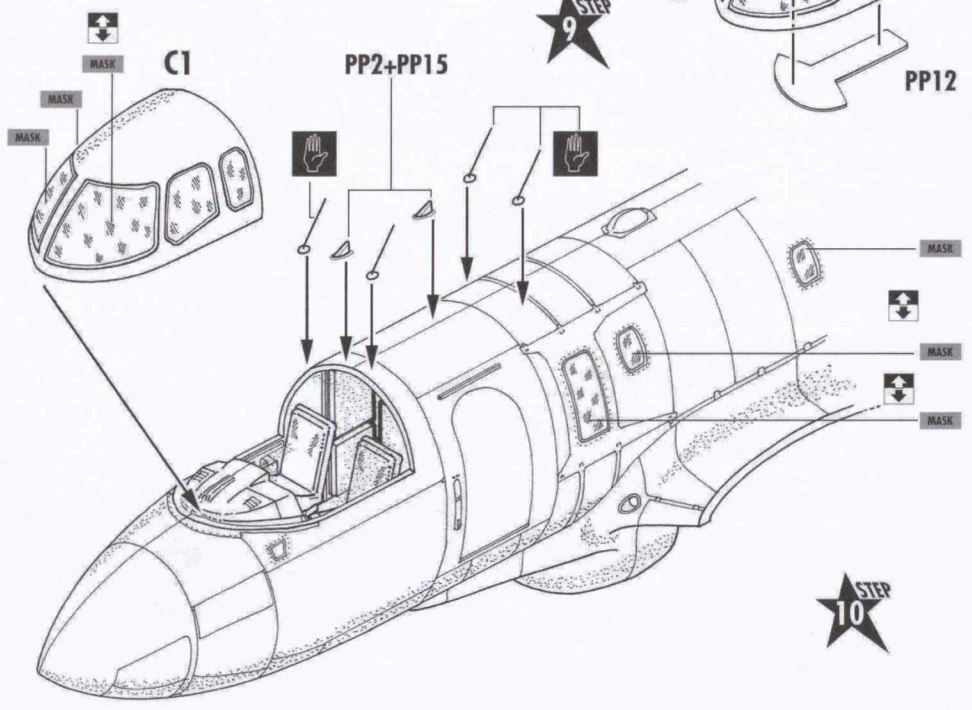

STEP 10

STEP
11

(26+27+28+29)

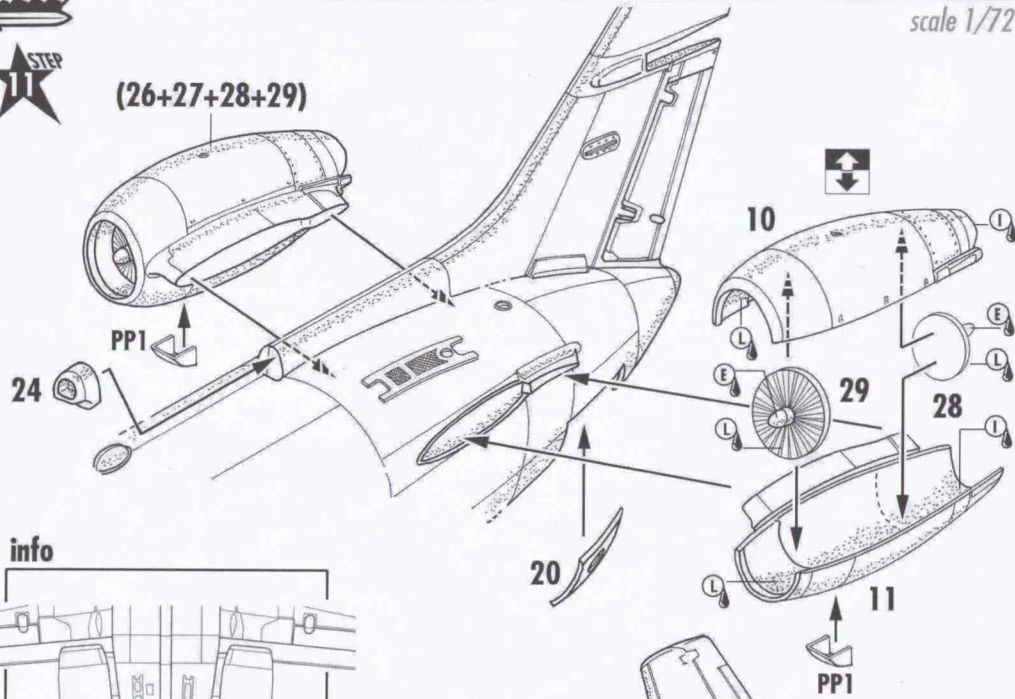

info

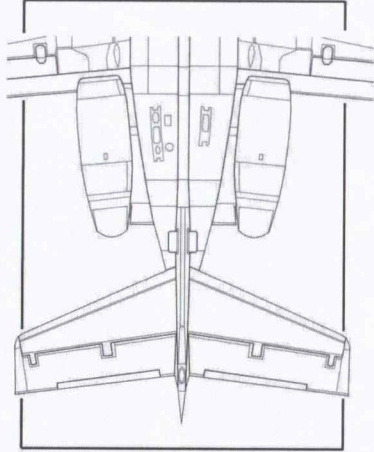

STEP
12

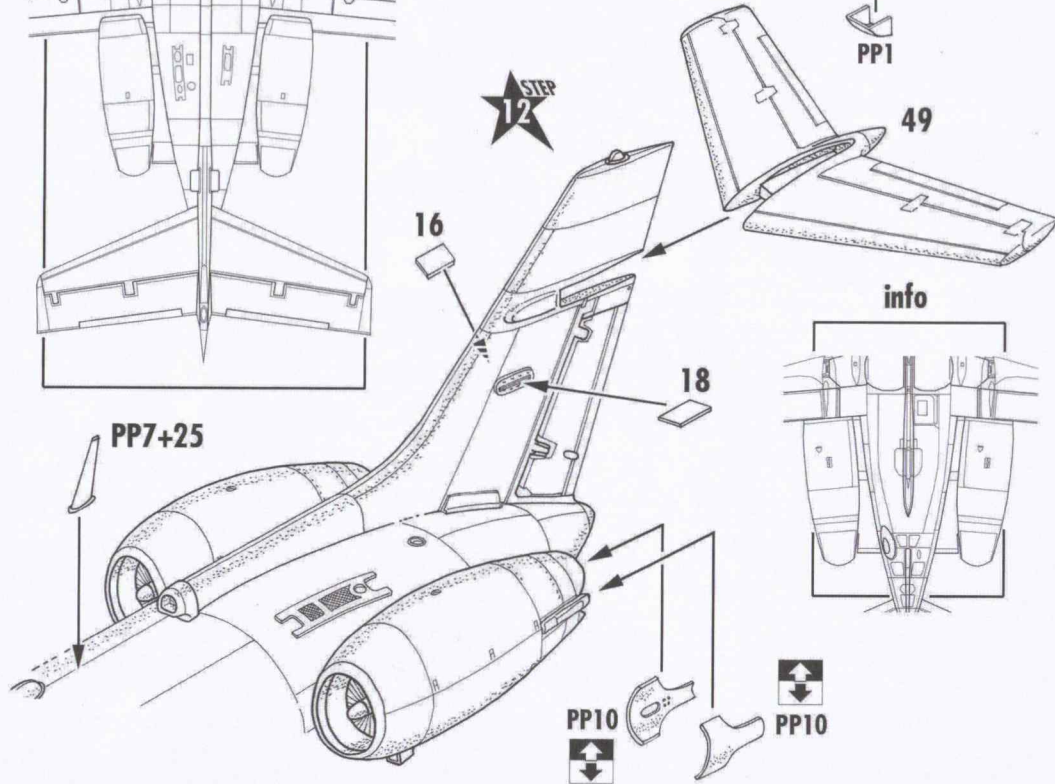

info

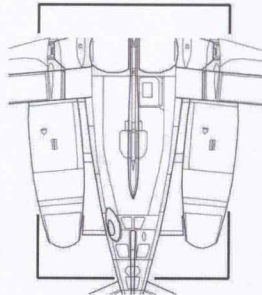

PP10



PP10

STEP
13

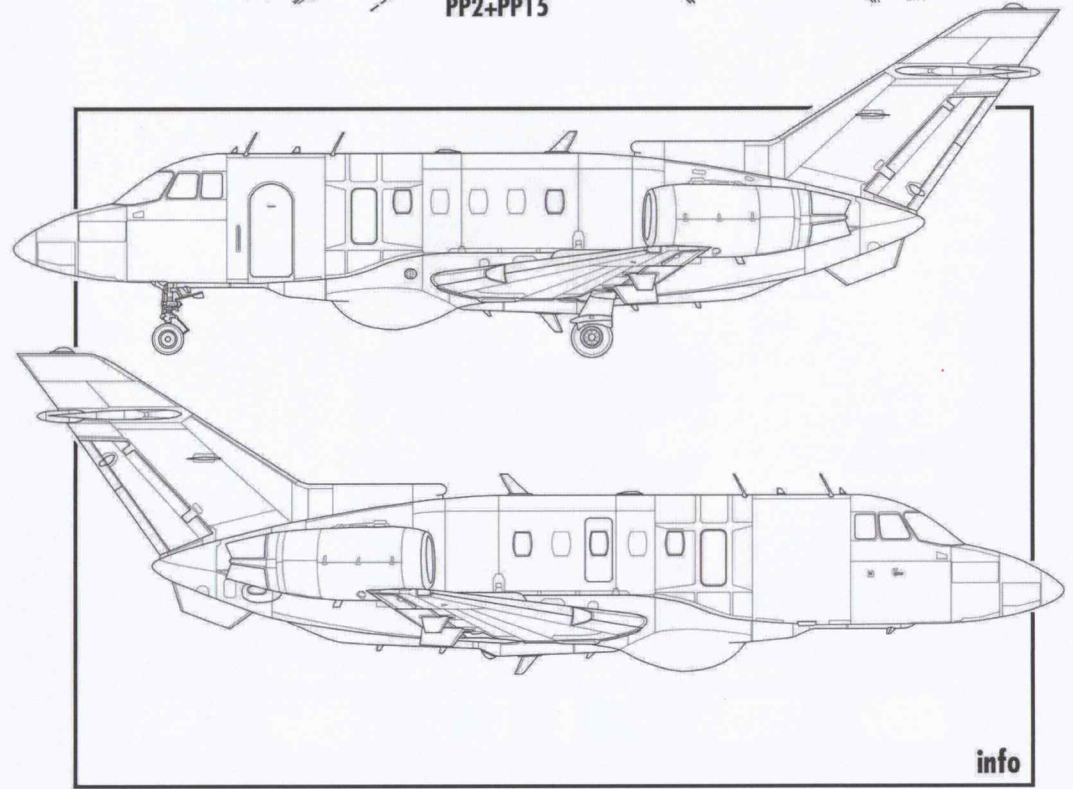
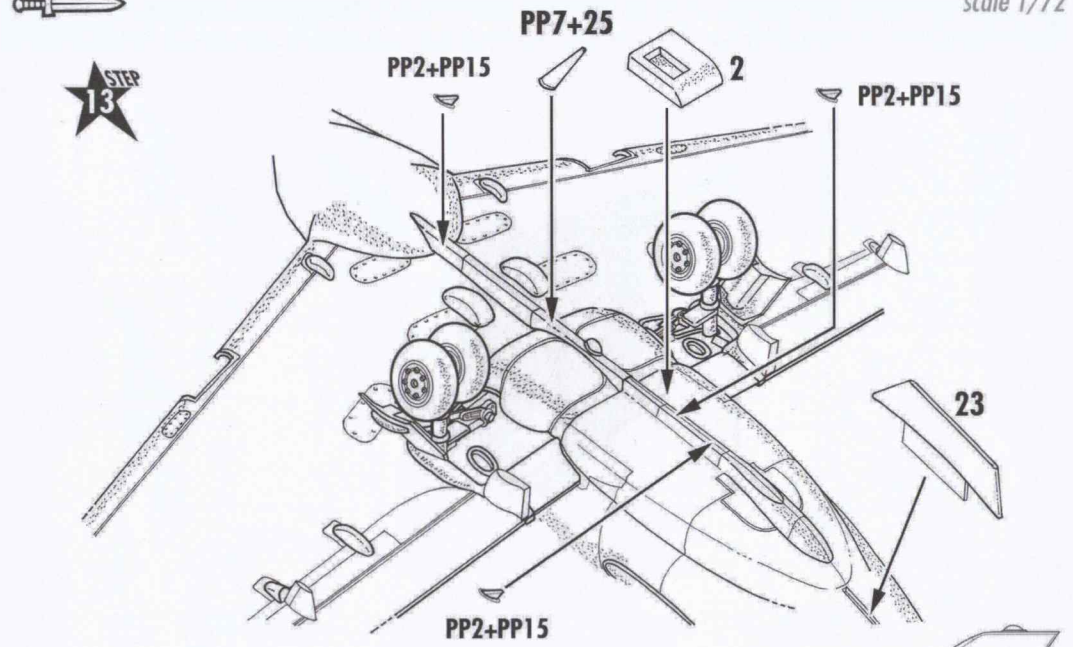

info

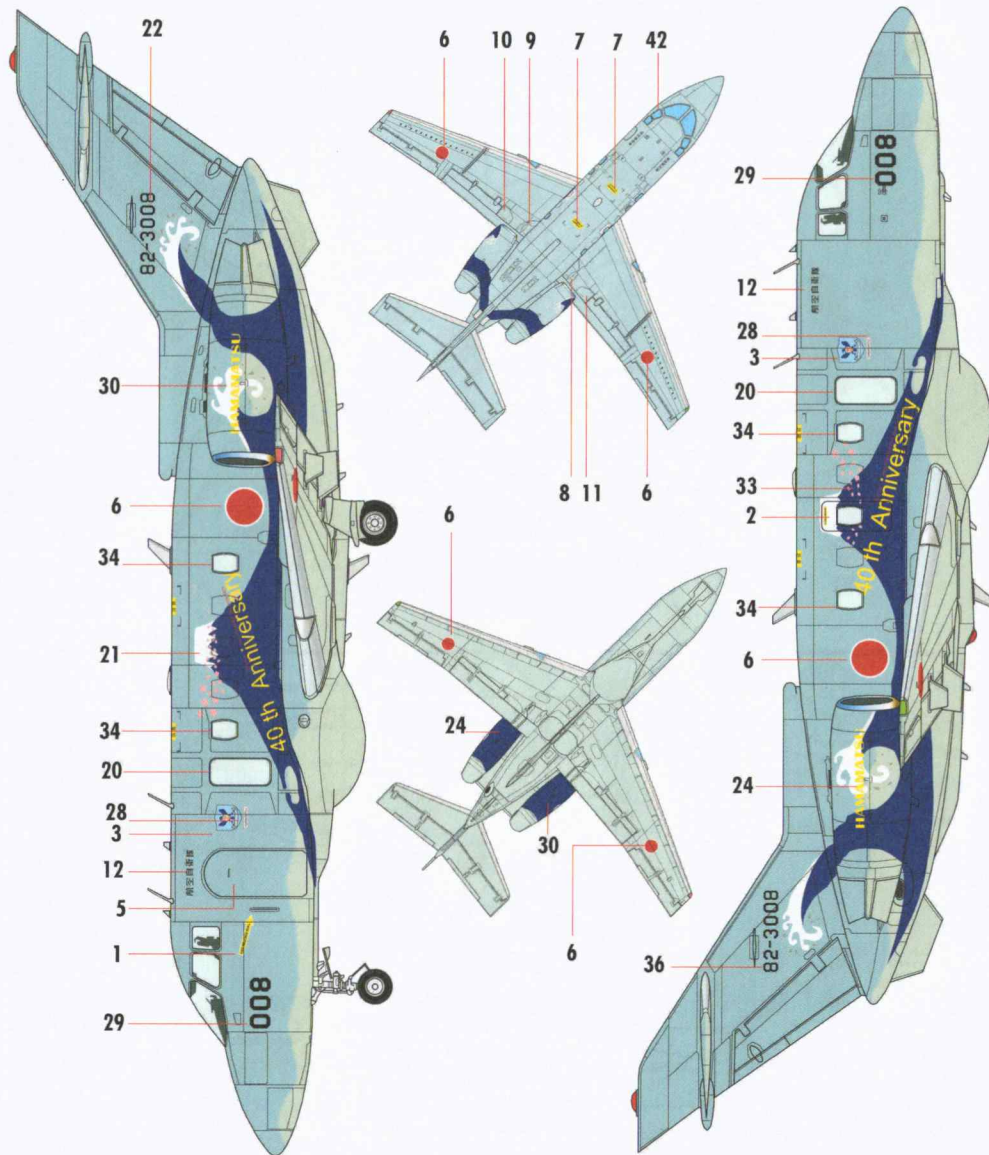

Natural metal	Chrome	Light Blue-Grey	Sky Light grey	Blue

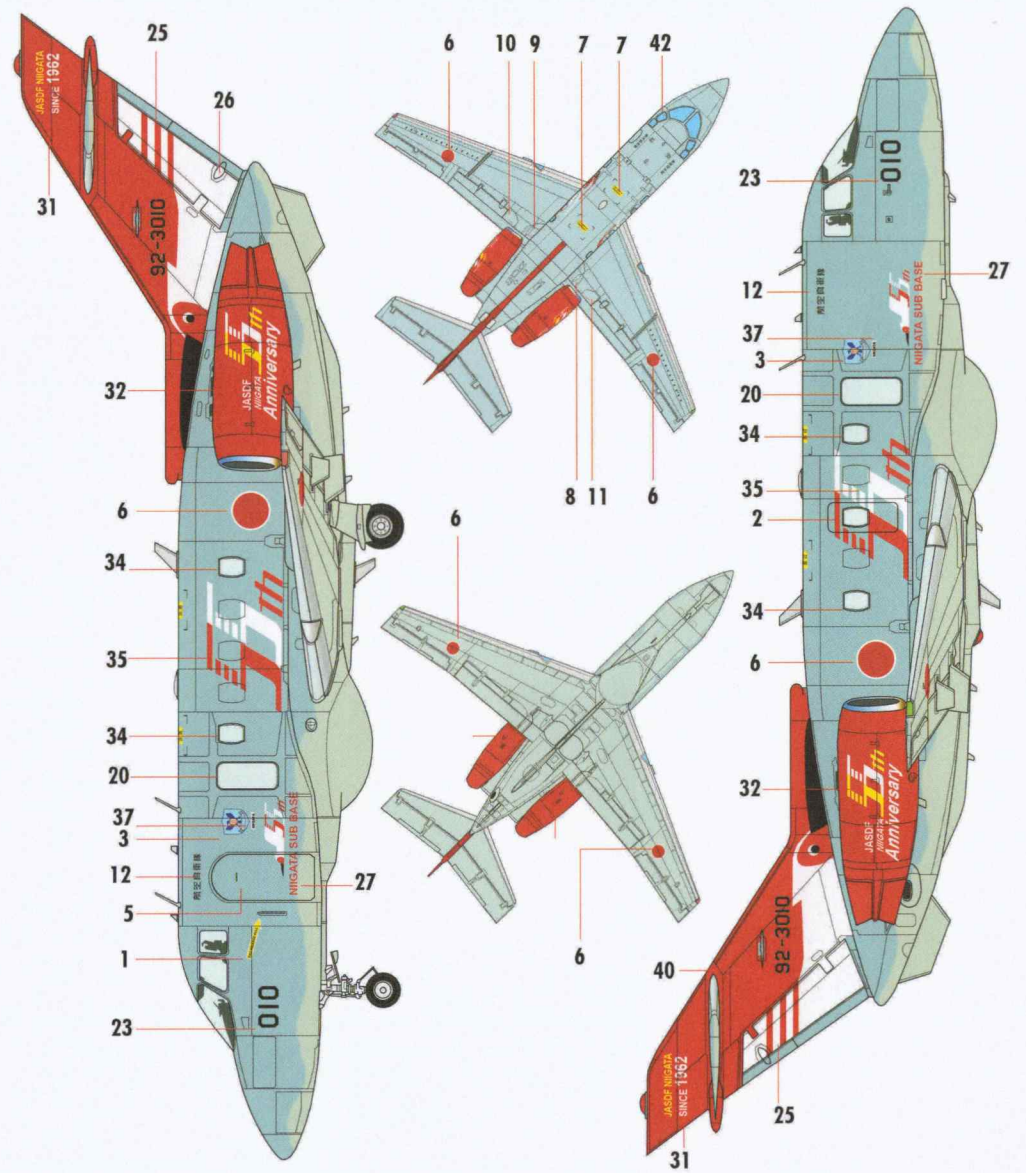

Natural metal	Chrome	Light Blue-Grey	Sky Light grey	Red

008 010 92-3010 7
1 2 3
008 010 92-3010
4 5 6 8

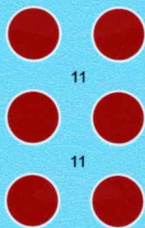
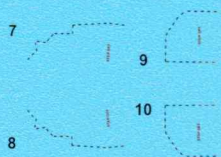

KOMATSU TRAINING SQ 14
KOMATSU TRAINING SQ 15

航空自衛隊
16
航空自衛隊



18 82-3008



13

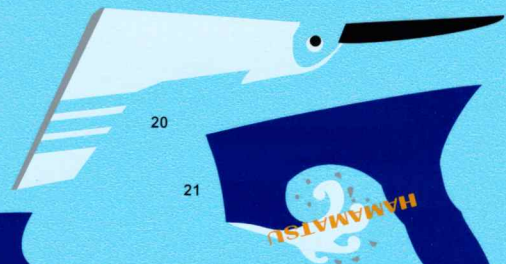

22
NIIGATA SUB BASE

22
NIIGATA SUB BASE

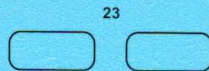

24
8002-28



25

28

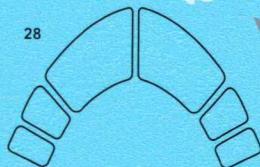

26

29



27
JASDF NIIGATA
SINCE 1962

27
JASDF NIIGATA
SINCE 1962

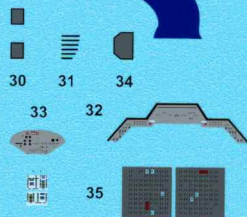

36



JASDF
NIIGATA
Anniversary

37
JASDF
NIIGATA
Anniversary

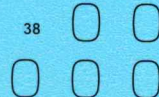

PRINTED BY TECHMOD



SW 72127SE U-125A