

FA2

SEA HARRIER FA2



Sea Harrier FA2

The Sea Harrier is a naval short take-off and vertical-landing/vertical take-off and landing jet fighter, reconnaissance and attack aircraft.

A second, updated version for the Royal Navy was made as the Sea Harrier FA2, improving its air to air abilities and weapons compatibilities, along with a more powerful engine. The first aircraft was entered service in 1993. Although withdrawn from active Royal Navy service in 2006, Sea Harriers are used to train naval aircraft handlers at the Royal Navy School of Flight Deck Operations. The Sea Harrier is in active use in the Indian Navy.

The Sea Harrier saw action in war again when it was deployed in the 1992–1995 conflict in Bosnia. It was used again in the 1999 NATO campaign against the Federal Republic of Yugoslavia in Operation Allied Force, Sea Harriers which operated from HMS Invincible frequently patrolled the airspace to keep Yugoslavian MiGs on the ground.

The Sea Harrier FA2 featured the Blue Vixen radar, which was described as one of the most advanced pulse doppler radar systems. The Sea Harrier FA2 also carried the AIM-120 AMRAAM missile, the first UK aircraft to be provided with this capability. An upgraded model of the Pegasus engine, the Pegasus Mk 106, was used in the Sea Harrier FA2; in response to the threat of radar-based anti aircraft weapons electronic countermeasures were added. Other improvements included an increase to the air-to-air weapons load, look-down radar, increased range, and improved cockpit displays.

偵察と対地攻撃を主任務とするシーハリヤーは、短距離/垂直離着陸が可能な艦上戦闘機です。

より強力なエンジンに換装したことに伴い、他機種との搭載火器の互換性、および空対空戦闘能力が向上するなど、イギリス海軍 後継戦闘機としての改良が加えられたシーハリヤー FA2は、1993年に就役しました。2006年にイギリス海軍の主力を退役した後、シーハリヤーは離発艦訓練を担うイギリス海軍兵学校での航空教官の訓練機として運用されたほか、インド海軍に於いては現在も現役機として作戦に従事しています。

前タイプのFRS1がフォークランド紛争で初の戦闘を経験したあと、再び1992～95年のボスニア紛争に展開したFA2が、戦闘行動を実施しました。また1999年には、ユーゴスラビア連邦共和国に対してNATO(北大西洋条約機構)軍が発動したアライド・フォース(コソボ空爆)作戦に加わり、イギリス海軍空母 インヴィンシブルから発艦したシーハリヤーが、地上に在るユーゴスラビア空軍のミグMiG-29を監視し、上空警戒任務に度々就くなど活躍を見せました。

最も先進的なドップラーレーダーシステムの1つと言われるブルーヴィクセンレーダーを装備するシーハリヤーFA2は、AIM-120アムラム空対空中距離ミサイルが搭載可能な最初のイギリス軍機で、改良型エンジンである高出力のペガサス Mk.106や、対空ミサイルの脅威に対する電子装備も搭載していました。またその他、空対空兵装の搭載能力やルックダウン レーダー装備による索敵能力も向上したことに加え、それら機能の簡便な操作性を実現した液晶ディスプレイや大型のHUD(ヘッドアップディスプレイ)を計器に踏まえたコックピットも、その改良点に含まれています。

CAUTION

*Read carefully and fully understand the instructions before commencing assembly.

*Keep out of reach of children. Children must not be allowed to put any parts in their mouths, or pull plastic bag over their heads.

*When using adhesives and paints, please make sure not to use them in closed room or near the fire.

*When assembling this kit, tools including knives are used. Extra care should be taken to avoid injury.

WARNING: CONTAIN SMALL PARTS NOT FOR CHILDREN UNDER 14 YEARS OF AGE.



Drill



Remove



2 Set



Bend



Optional



Decal



Super Glue



Fill Hole



No Cement



Be Careful

TOOLS RECOMMENDED

Cement



Side Cutter



Modeling Knife

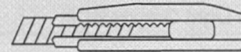

Tweezers



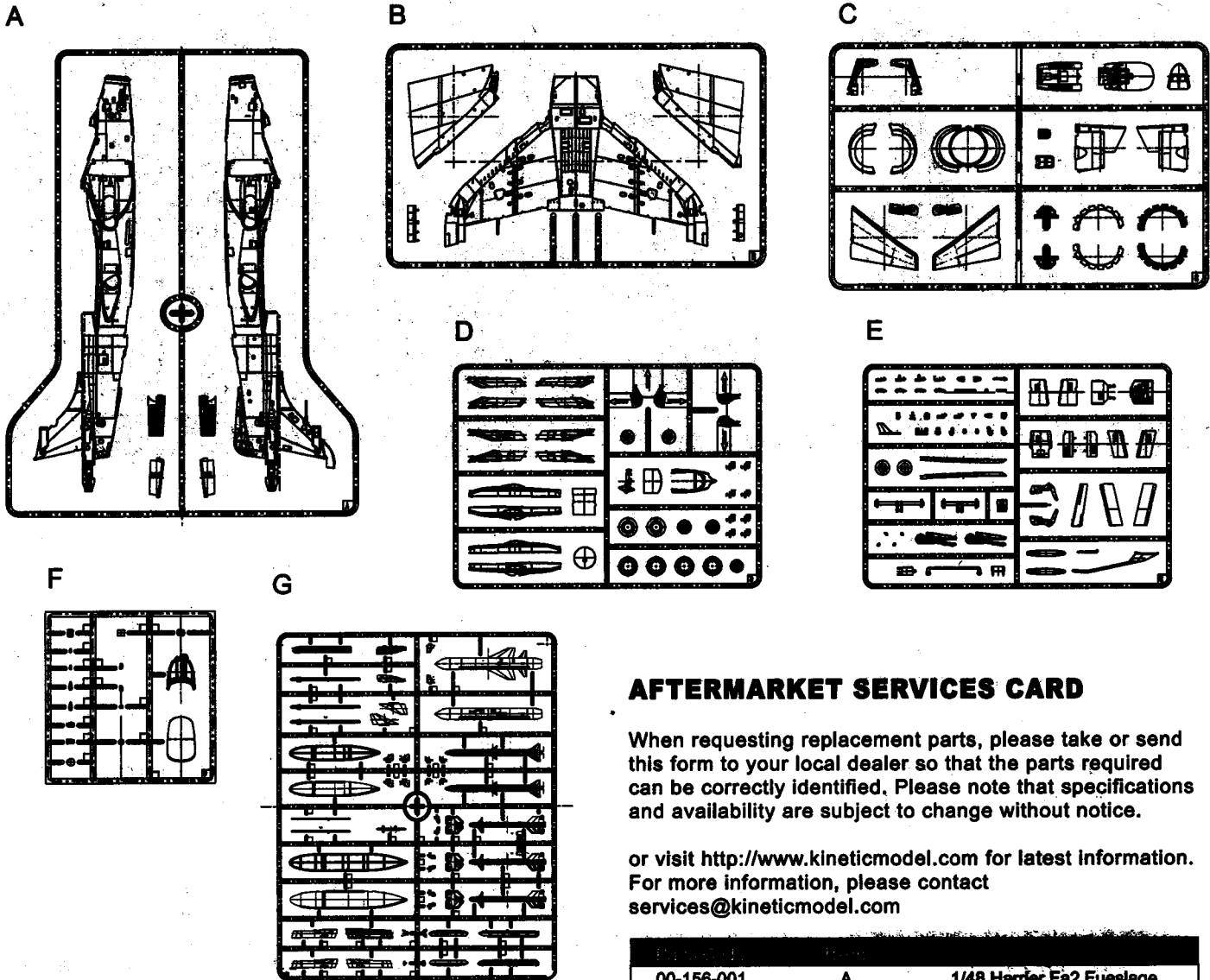

AFTERMARKET SERVICES CARD

When requesting replacement parts, please take or send this form to your local dealer so that the parts required can be correctly identified. Please note that specifications and availability are subject to change without notice.

or visit <http://www.kineticmodel.com> for latest information. For more information, please contact services@kineticmodel.com

00-156-001	A	1/48 Harrier Fa2 Fueselage
00-156-002	B	1/48 Harrier Fa2 Wings
00-156-003	C	1/48 Harrier Fa2 Intake
00-156-004	D	1/48 Harrier Fa2 Parts
00-156-005	E	1/48 Harrier Fa2 Landing Gear
00-156-006	F	1/48 Harrier Fa2 Clear Parts
00-156-007	G	1/48 Harrier Missile Sprue/tank
01-156-48041	Decal	1/48 Harrier Fa2
06-156-48041	PE	1/48 Harrier Fa2 Pe

PAINT INDEX

COLOR	33	33	4768AP	Xf-18	-	950	057
Flat Black	33	33	4768AP	Xf-18	-	950	057
Flat White	130	1	4796AP	X-2	-	951	001
Clear Red	1321	47	-	-	-	934	-
Clear Green	1325	-	-	-	-	-	-
Us Ghost Grey	127	308	-	-	-	-	-
Gun Metal	53	-	4681AP	-	-	-	-
royal Blue	15	5	-	-	-	899	91
Medium Sea Grey(Fs36270)	32	335	-	-	-	870	51
Khaki Grey	26	-	-	-	-	880	-
Steel Grey	87	-	-	-	-	-	-
Sea Light Grey(Fs36118)	85	317	4313AP	-	-	868	53

denotes Humbrol Paints

1

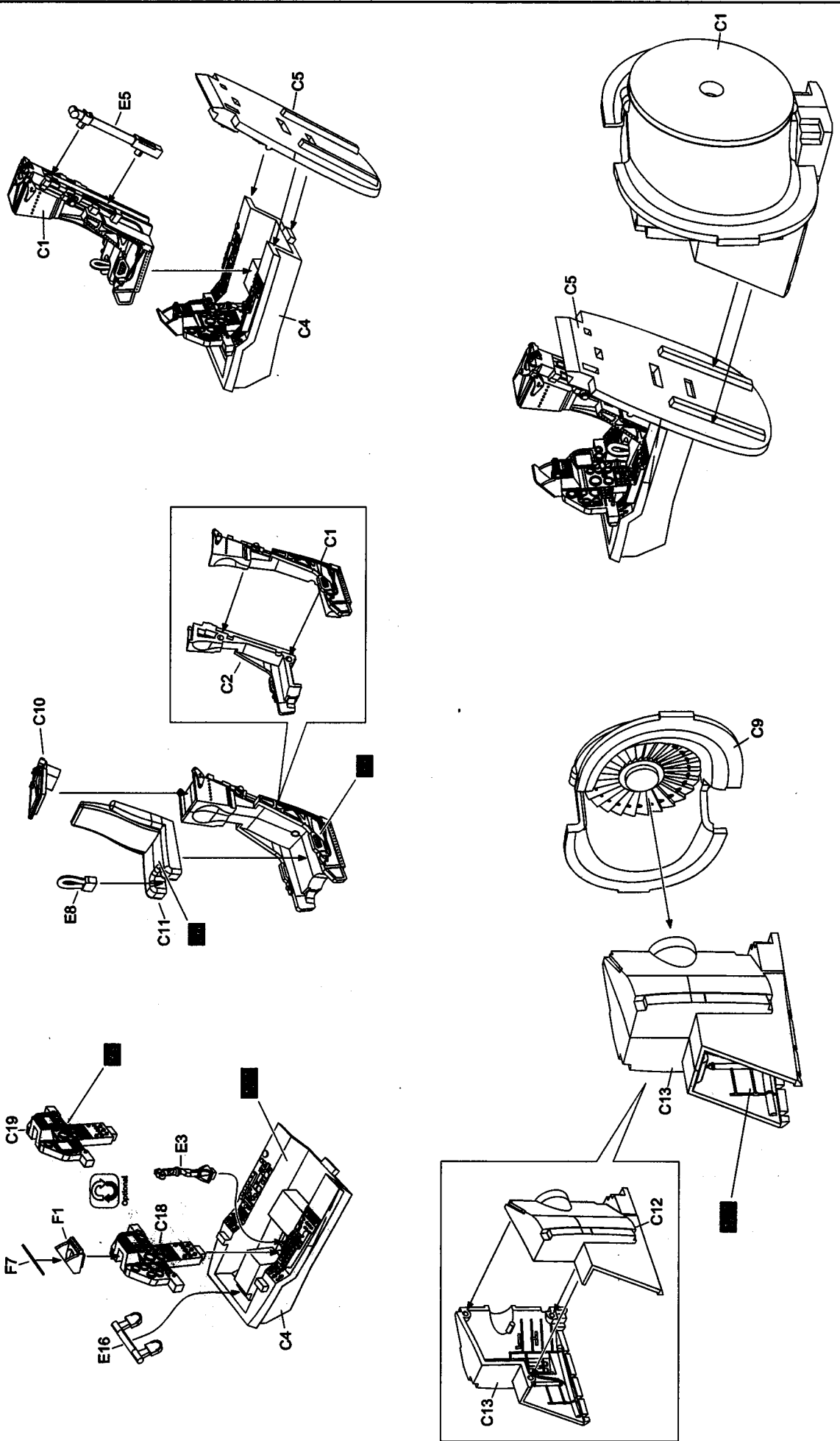

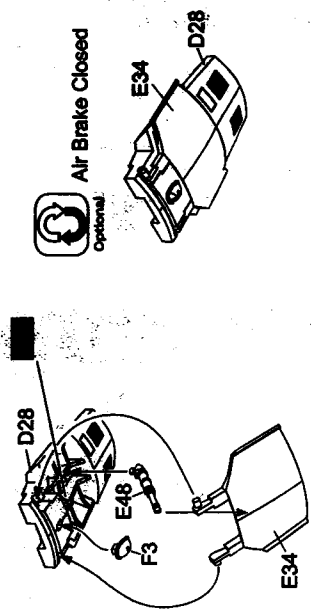
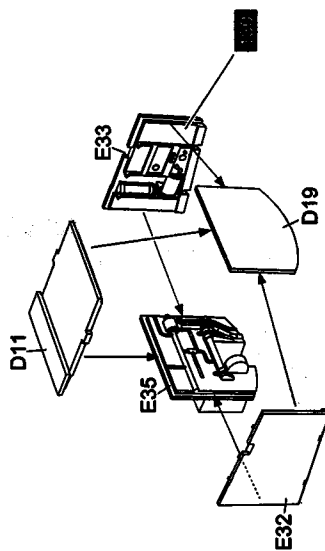
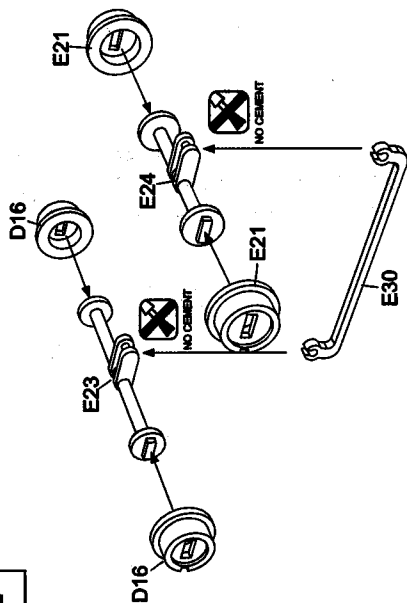
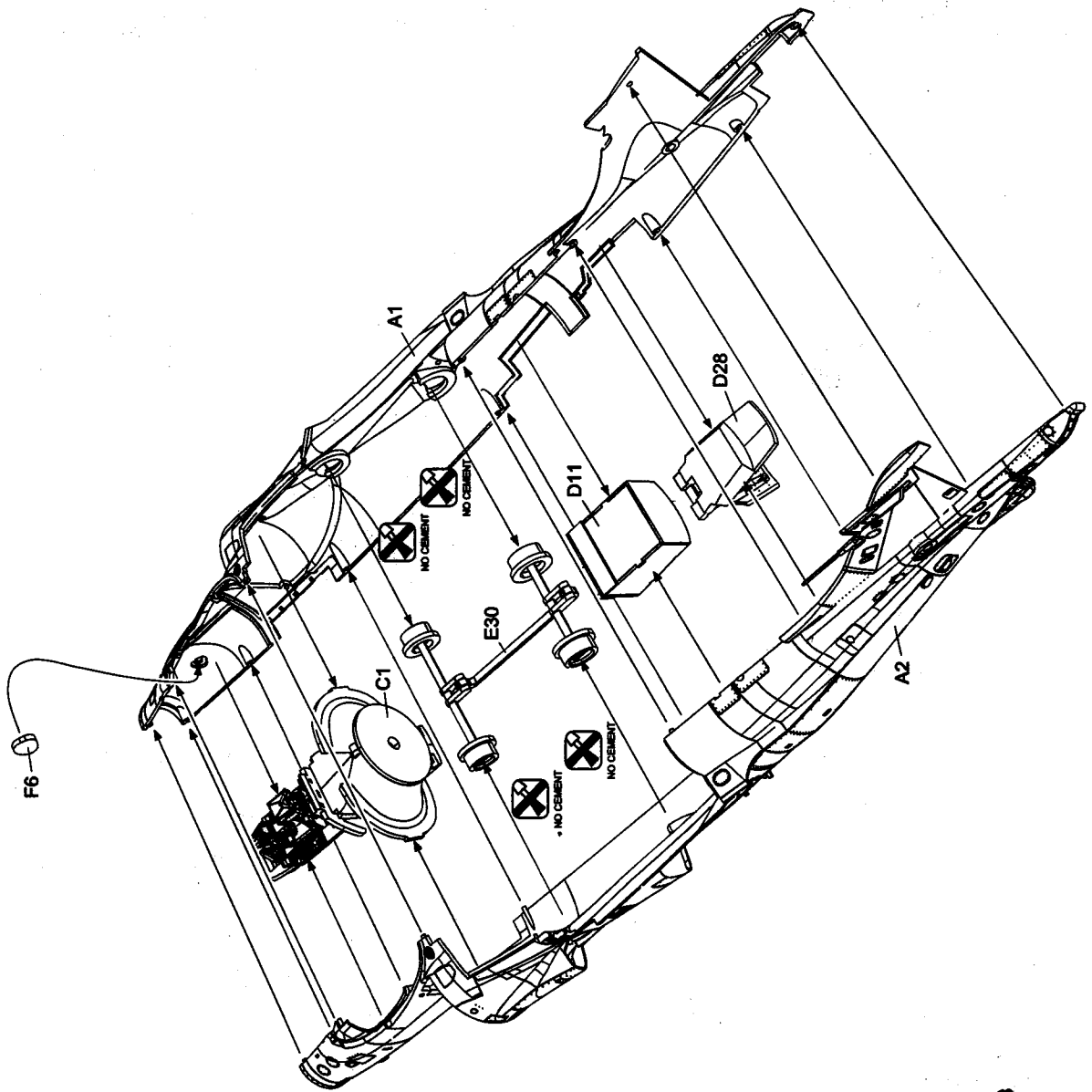

2

4

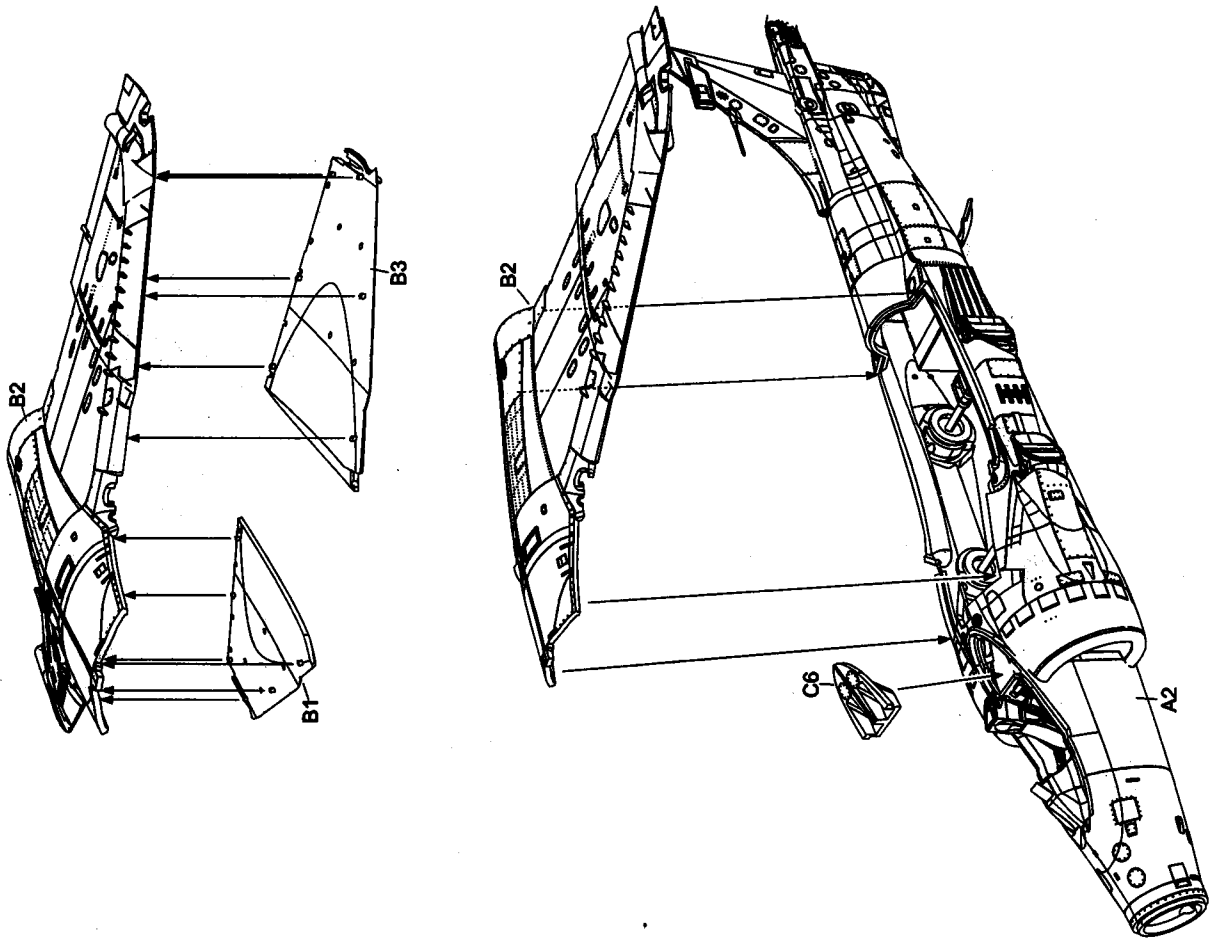

3

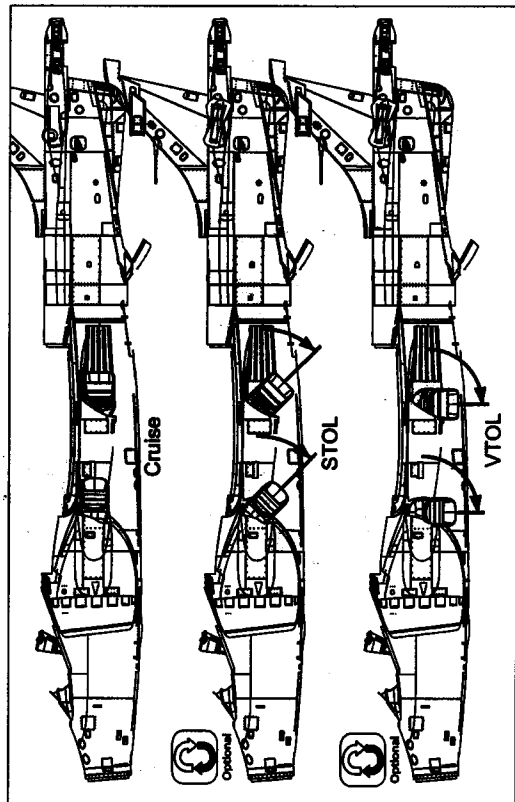
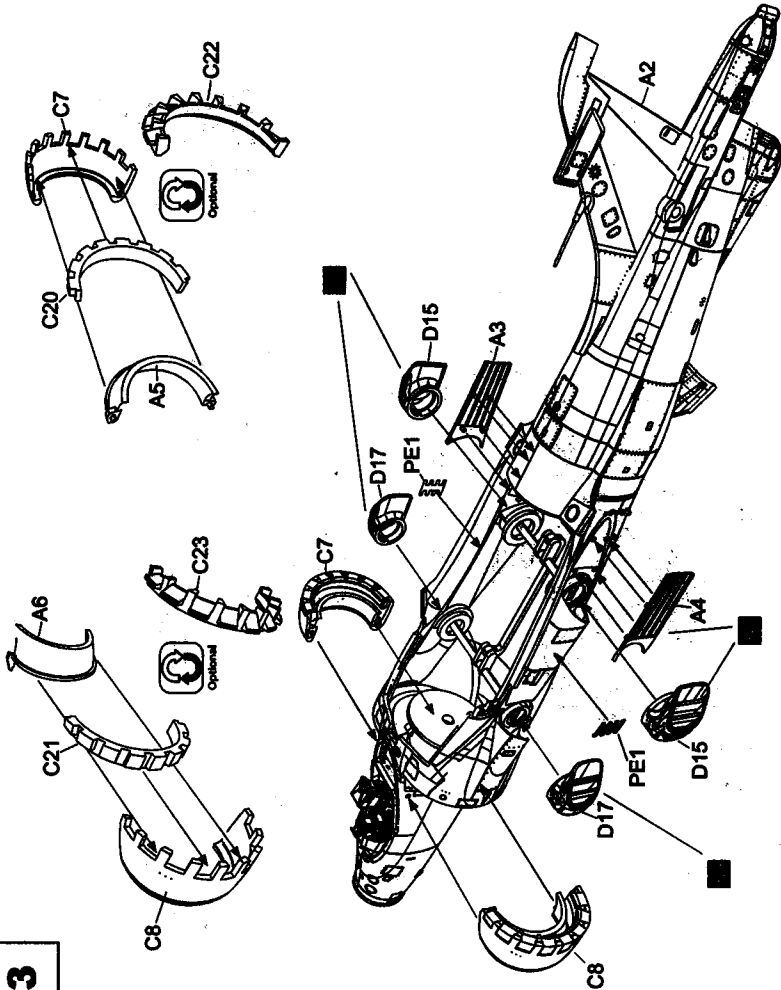

6

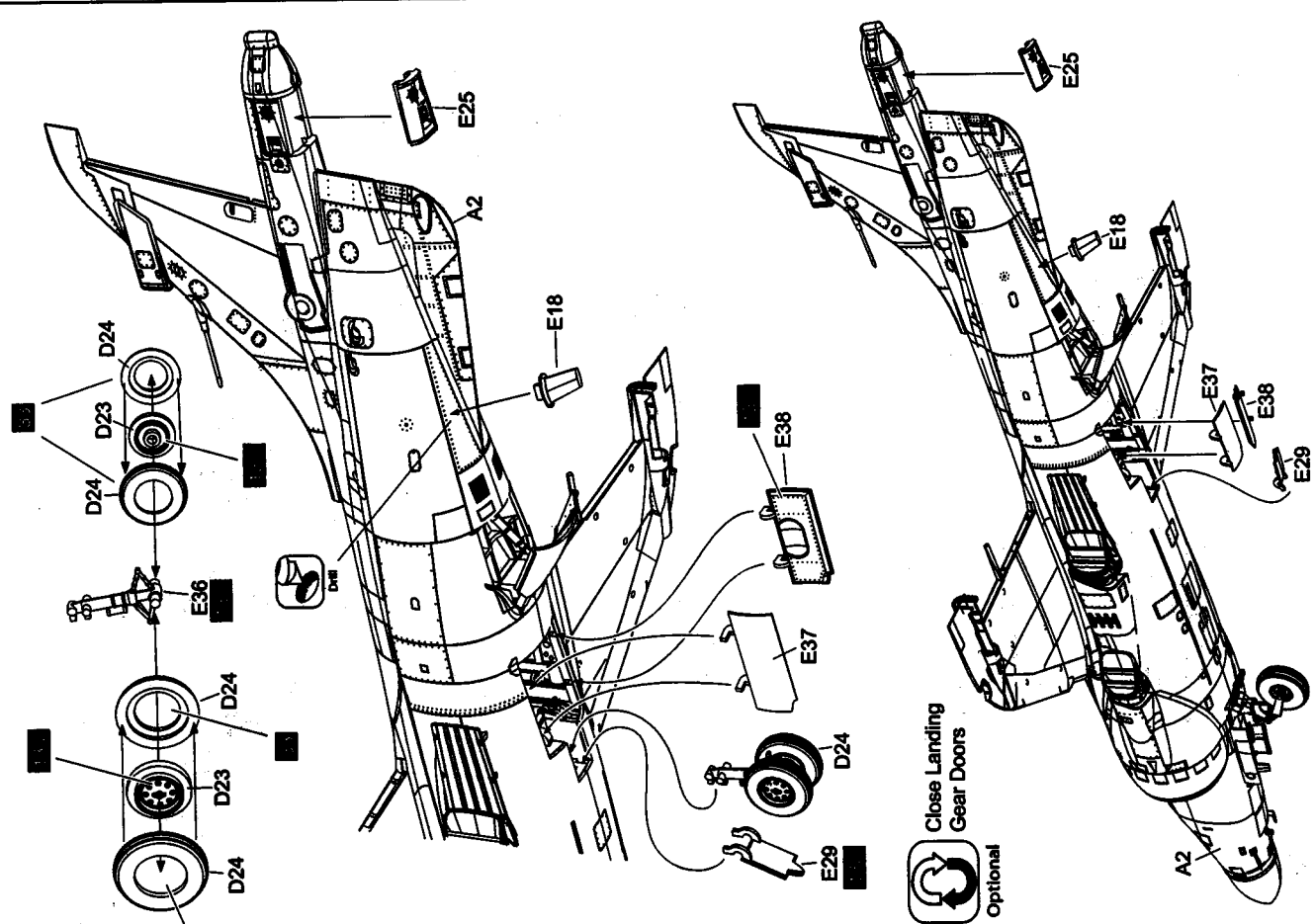

5

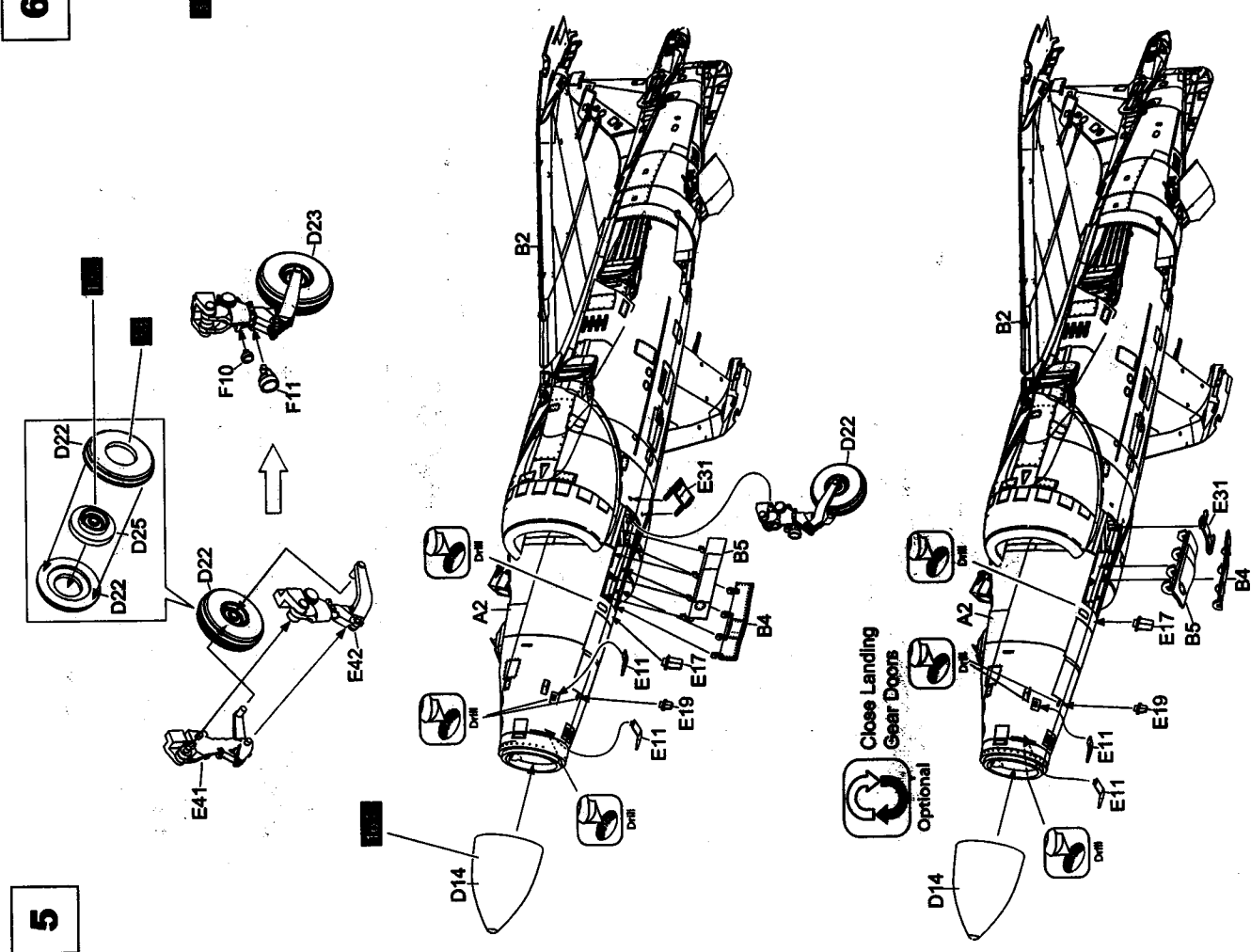

7

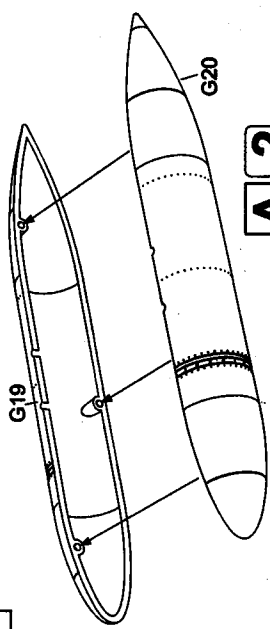

A x2

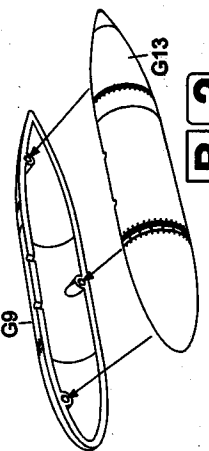

B x2

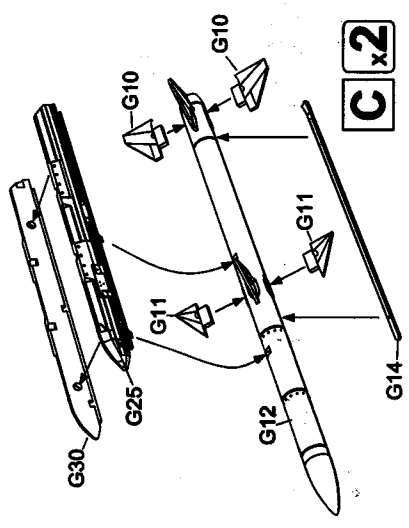

C x2

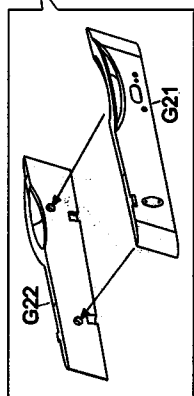

D x2

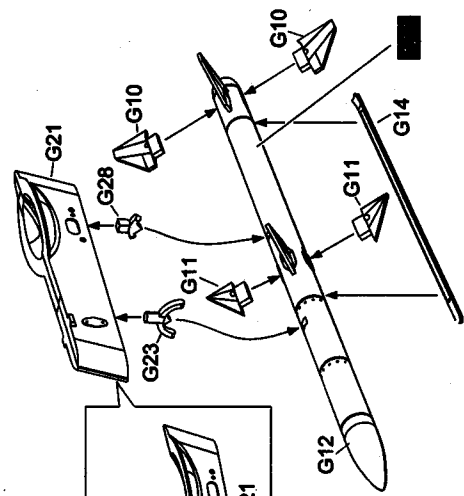

E x2

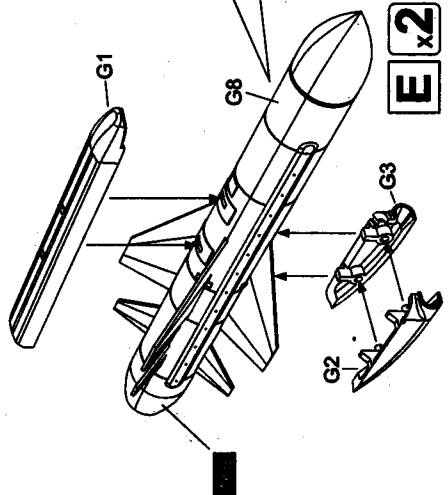
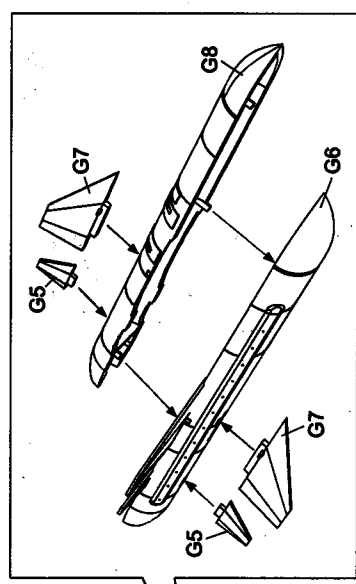

G x2

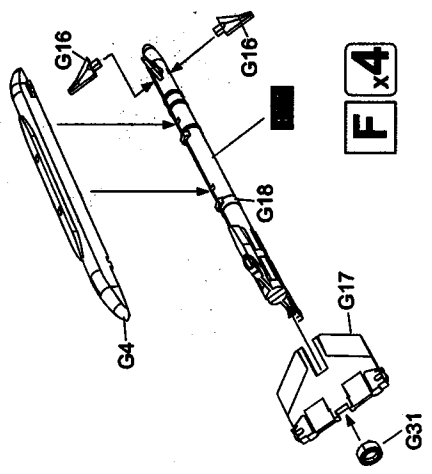

H x2

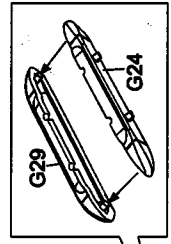

I x2

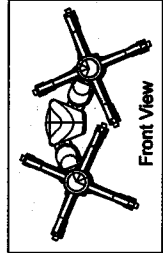
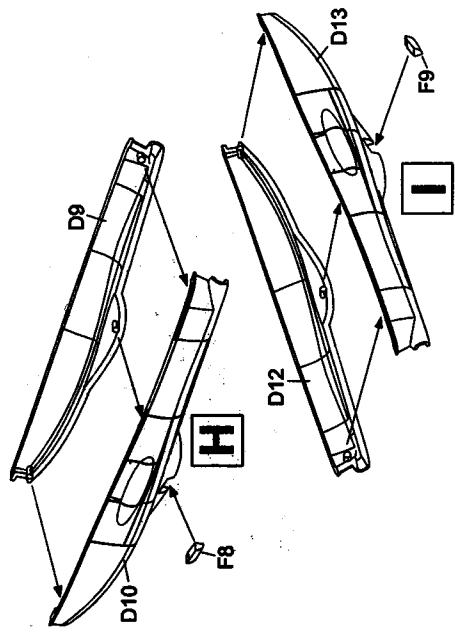

9

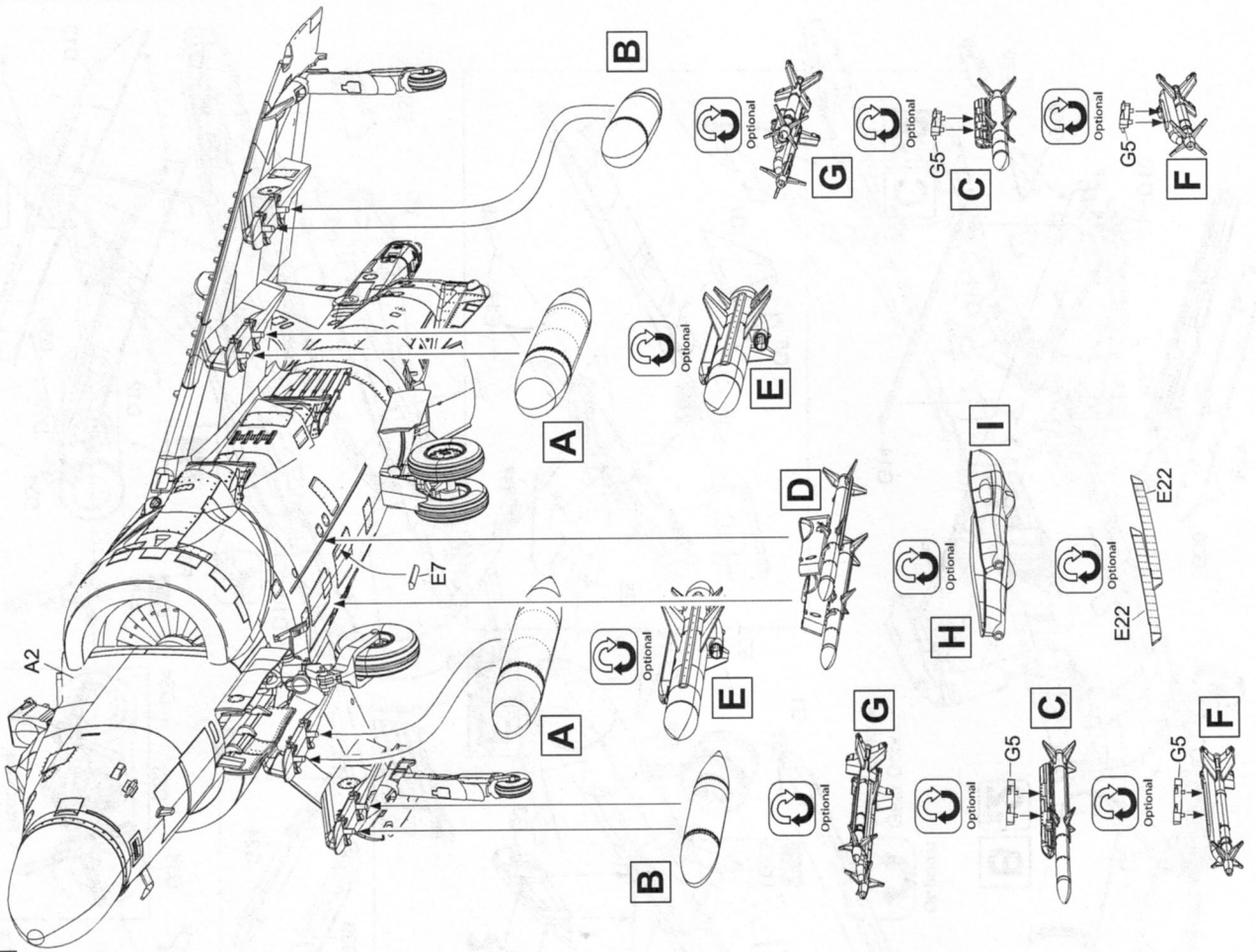

8

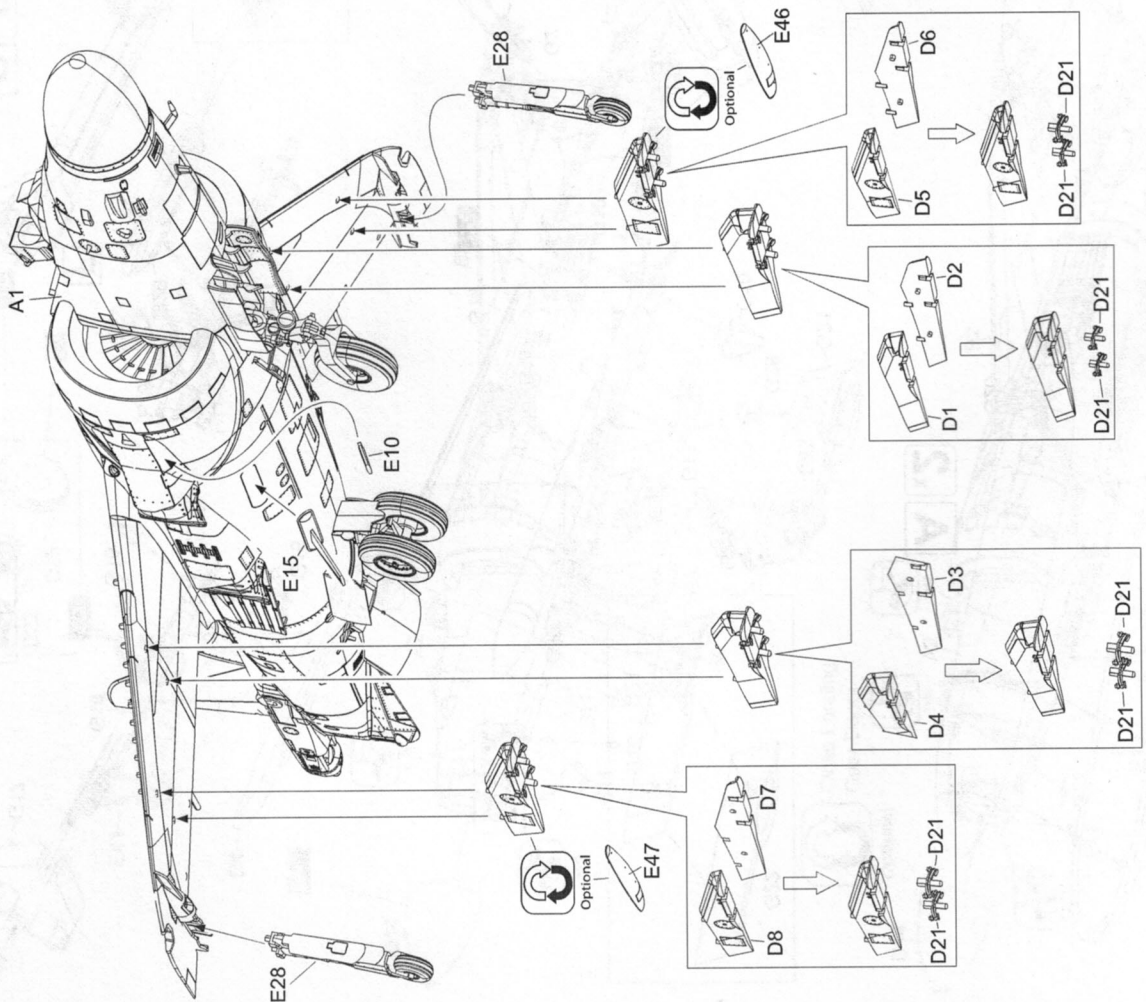

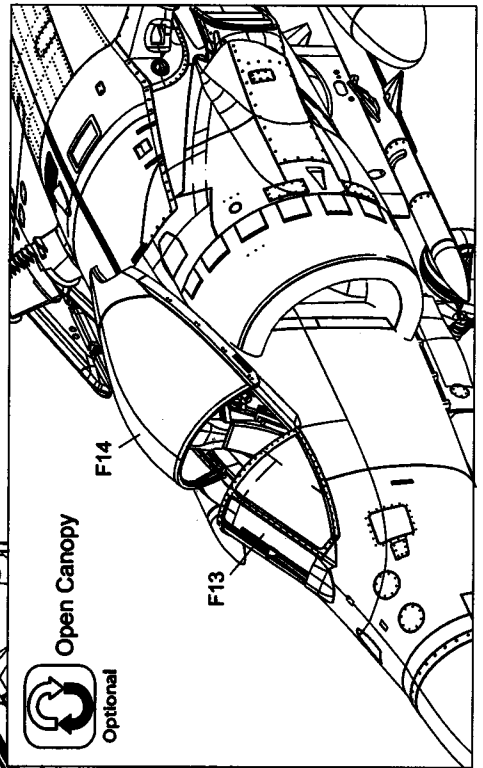
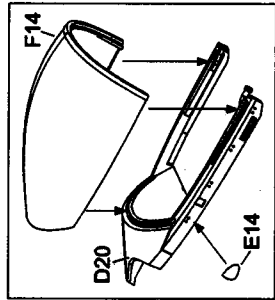
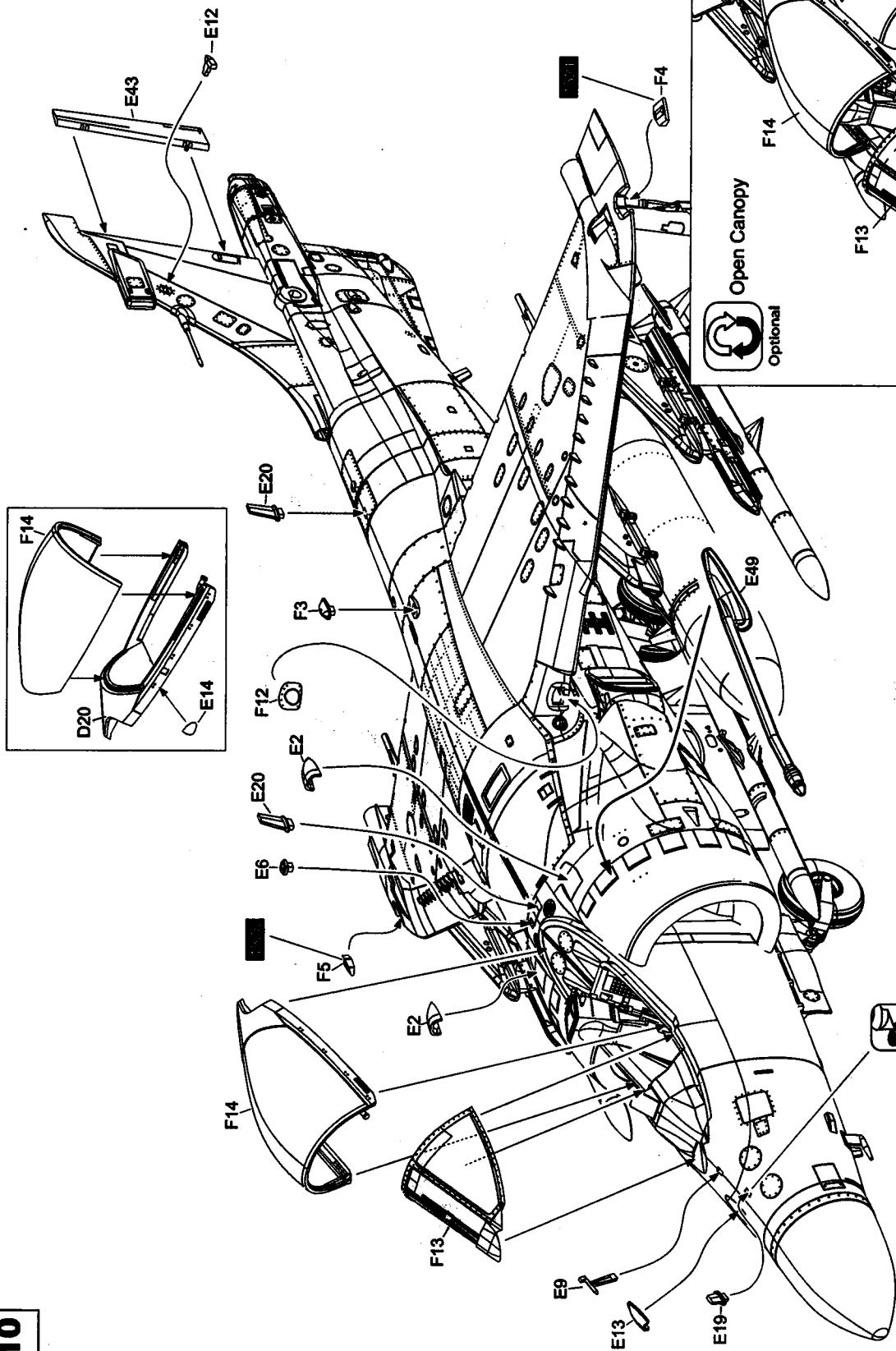

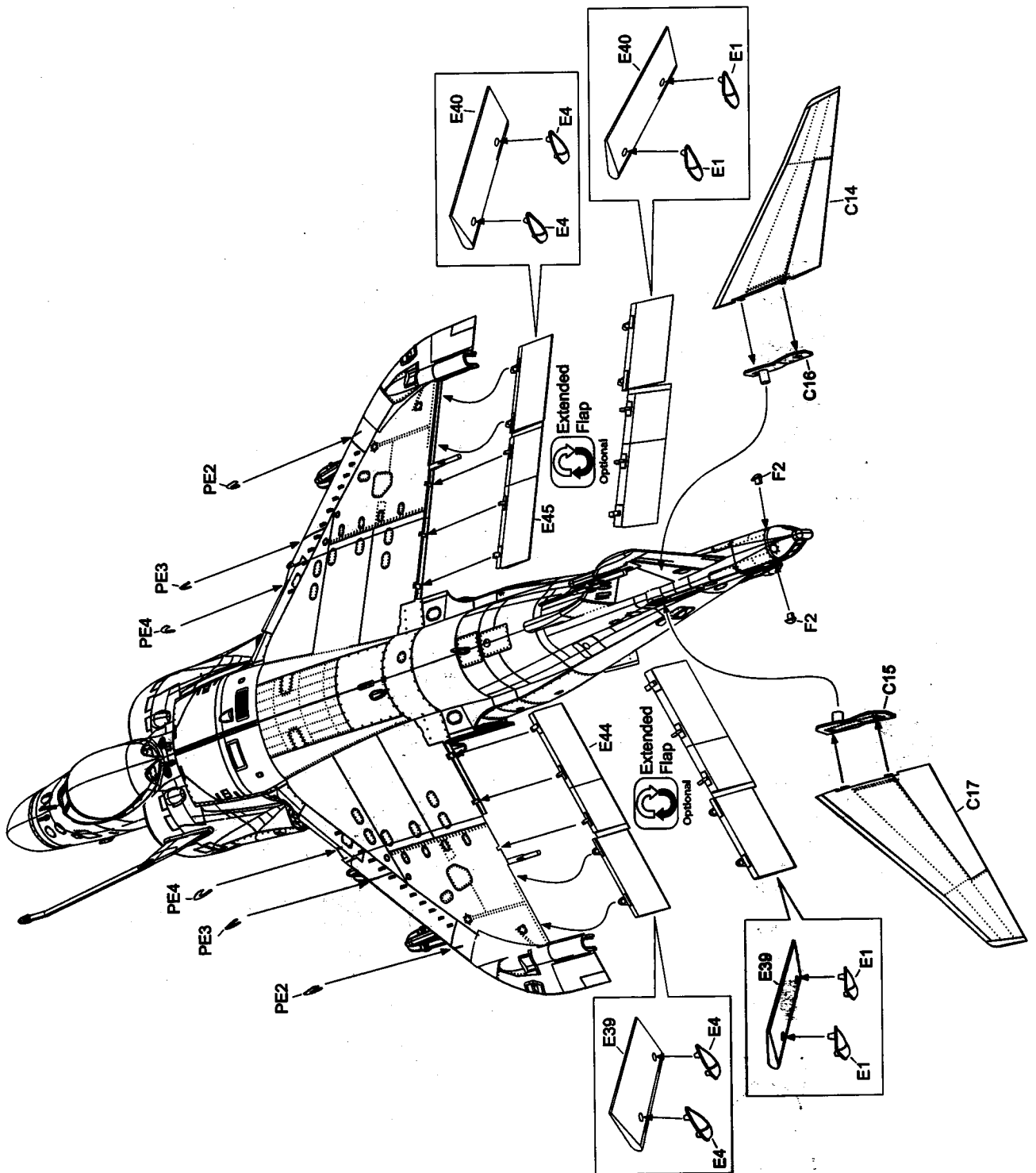

**Common Markings
on all grey schemes**

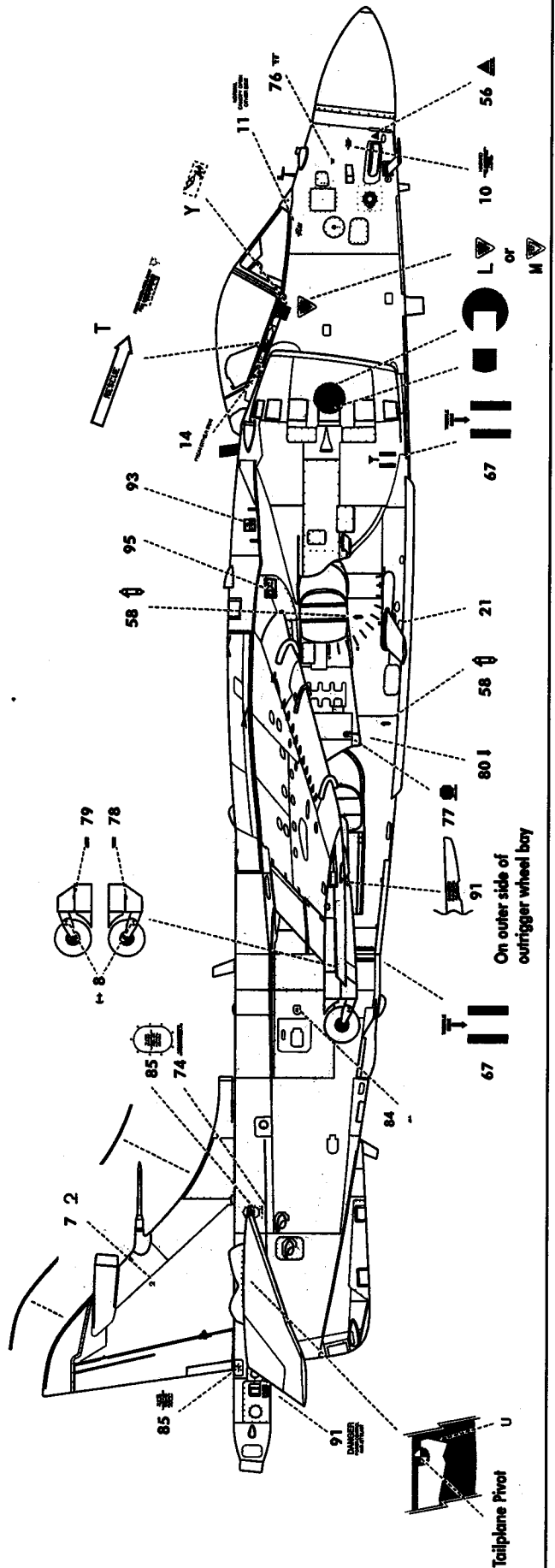
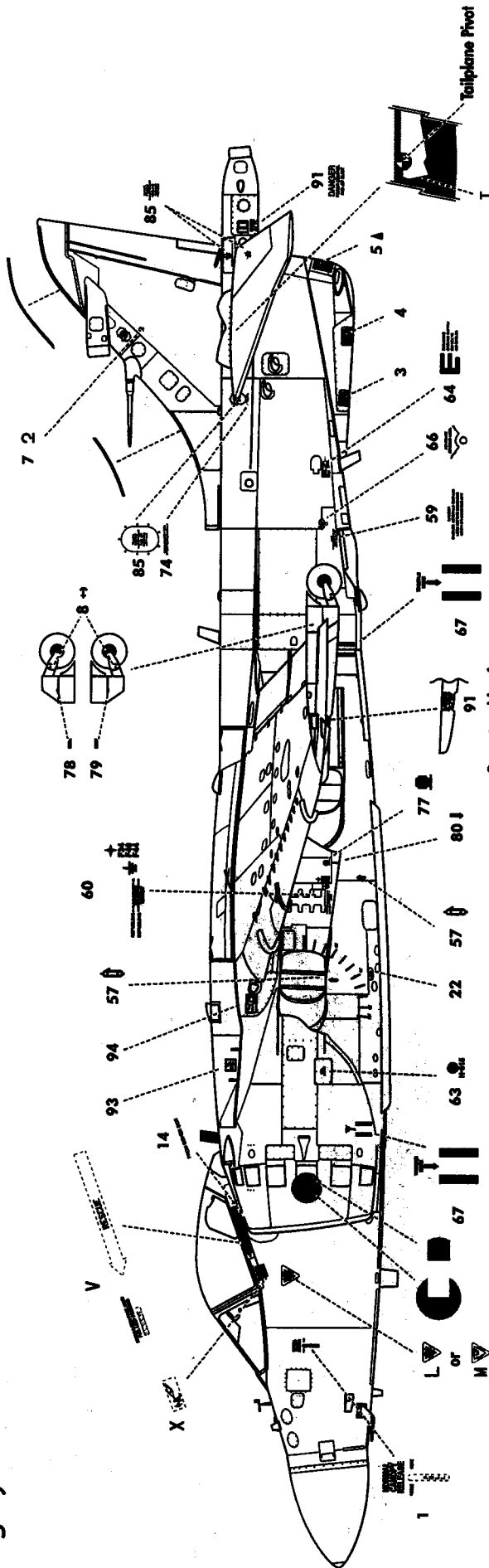

Stencil Locations

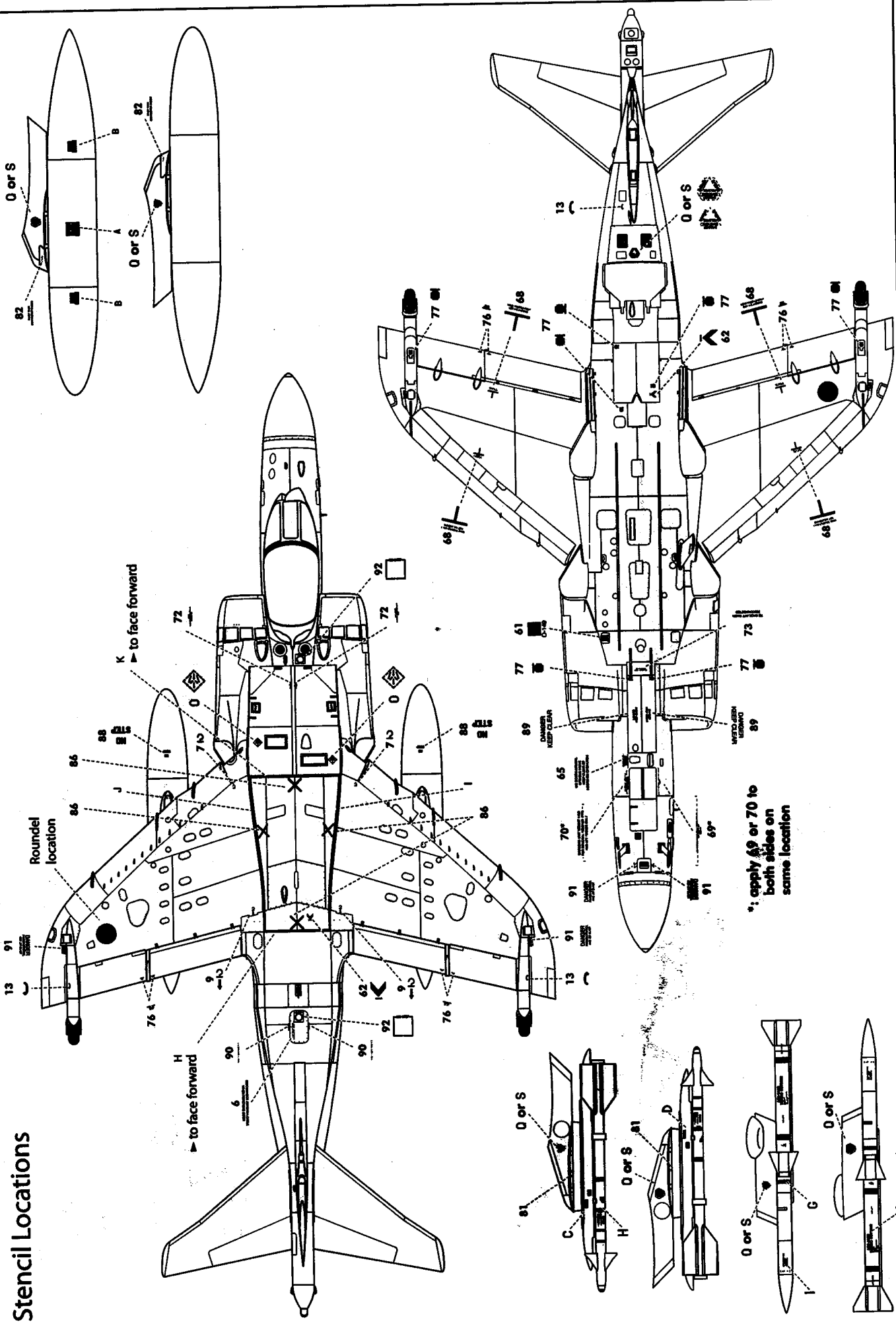

*: apply 69 or 70 to both sides on same location

1. ZD613 "Satan 1" in decommissioning scheme of 800 Squadron, Royal Navy, March 2004.

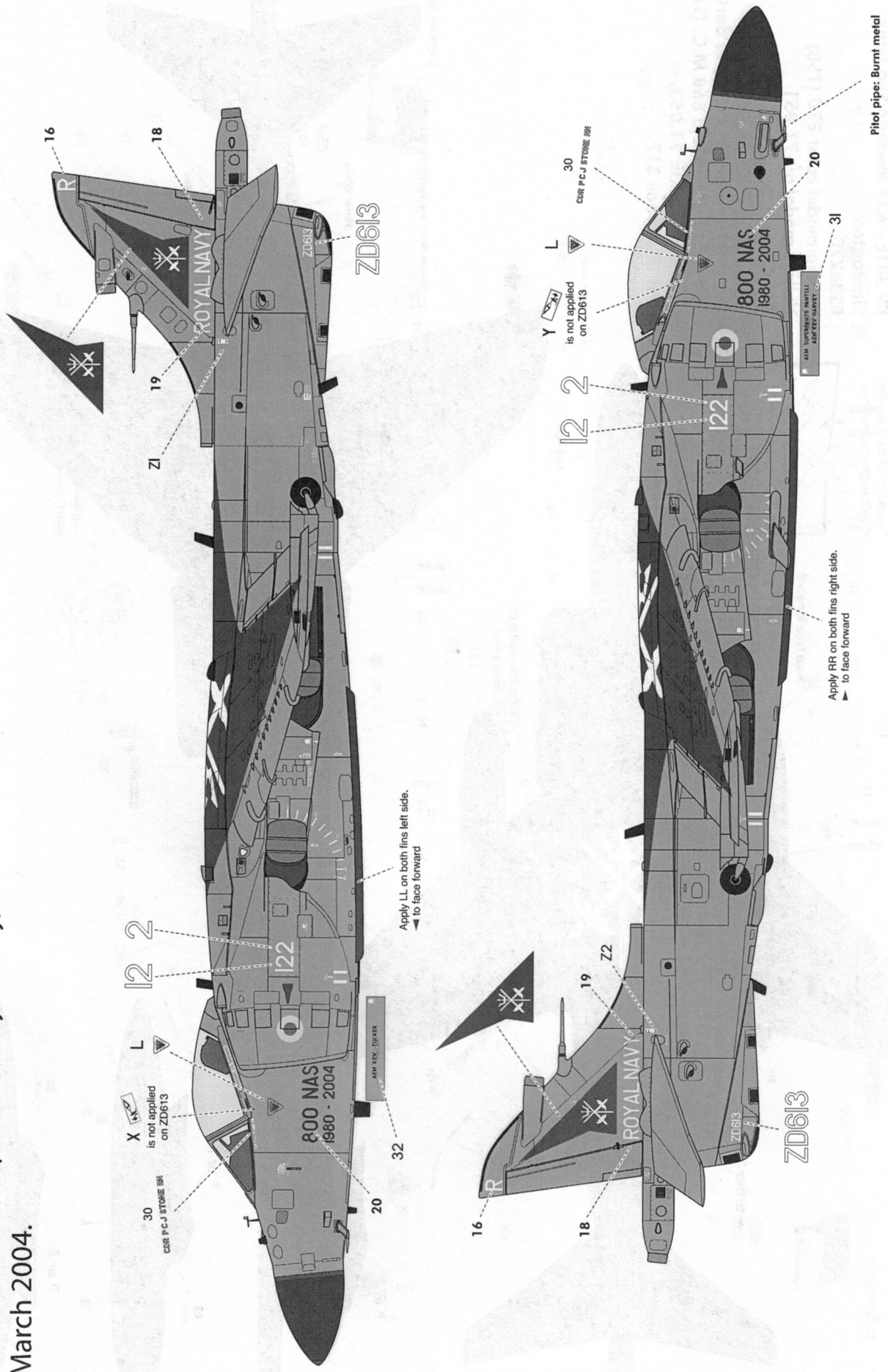

Paint entire aircraft into
BS 381c - 637 Medium Sea Grey.

Similar to:
FS36270

Vallejo model color 870 (158)

Vallejo model air 71.051

GSI Creos 335

Except the radome which gets darker:
use FS 36118, Vallejo 868 M.C. (163),
Vallejo model air 71.053,
and GSI Creos 317.

Squadron crest is painted
OVER engine room lines

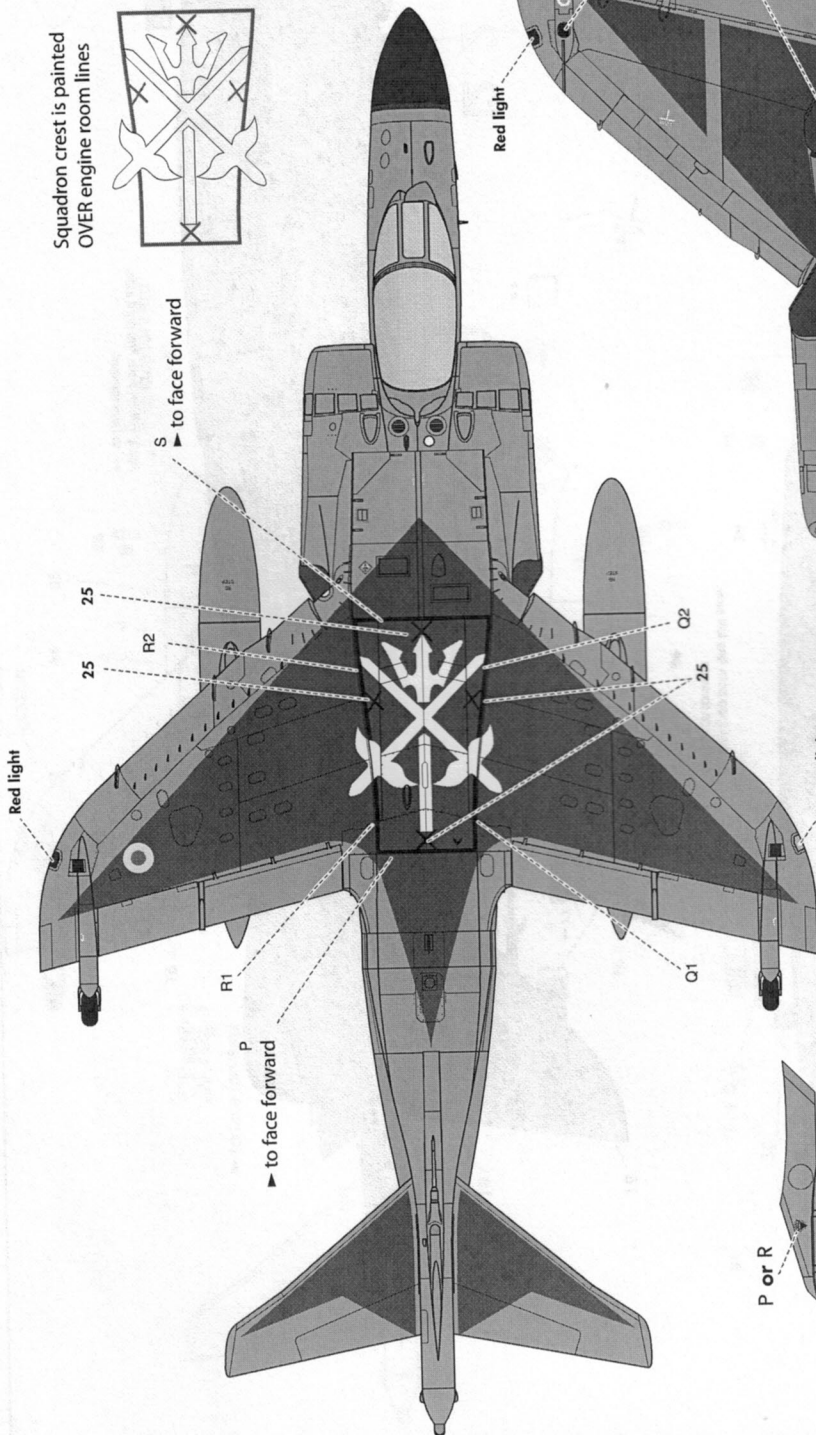
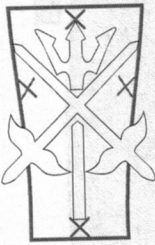

"2" on gear door

Red light

Nozzle and heat shield: Burnt metal

Flare: White

Chaff: Red

Green light
(Note: NOT blue)

P or R

P or R

P or R

82

B

A

P or R

82

This aircraft have been painted
 gloss Royal blue over white:
 use FS15044,
 Vallejo model color 899 (50)
 Vallejo model air 71.091
 GSI Creos 5

Except the radome which is same with
 the grey scheme:
 use FS 36118, Vallejo 868 M.C. (163),
 Vallejo model air 71.053,
 and GSI Creos 317.

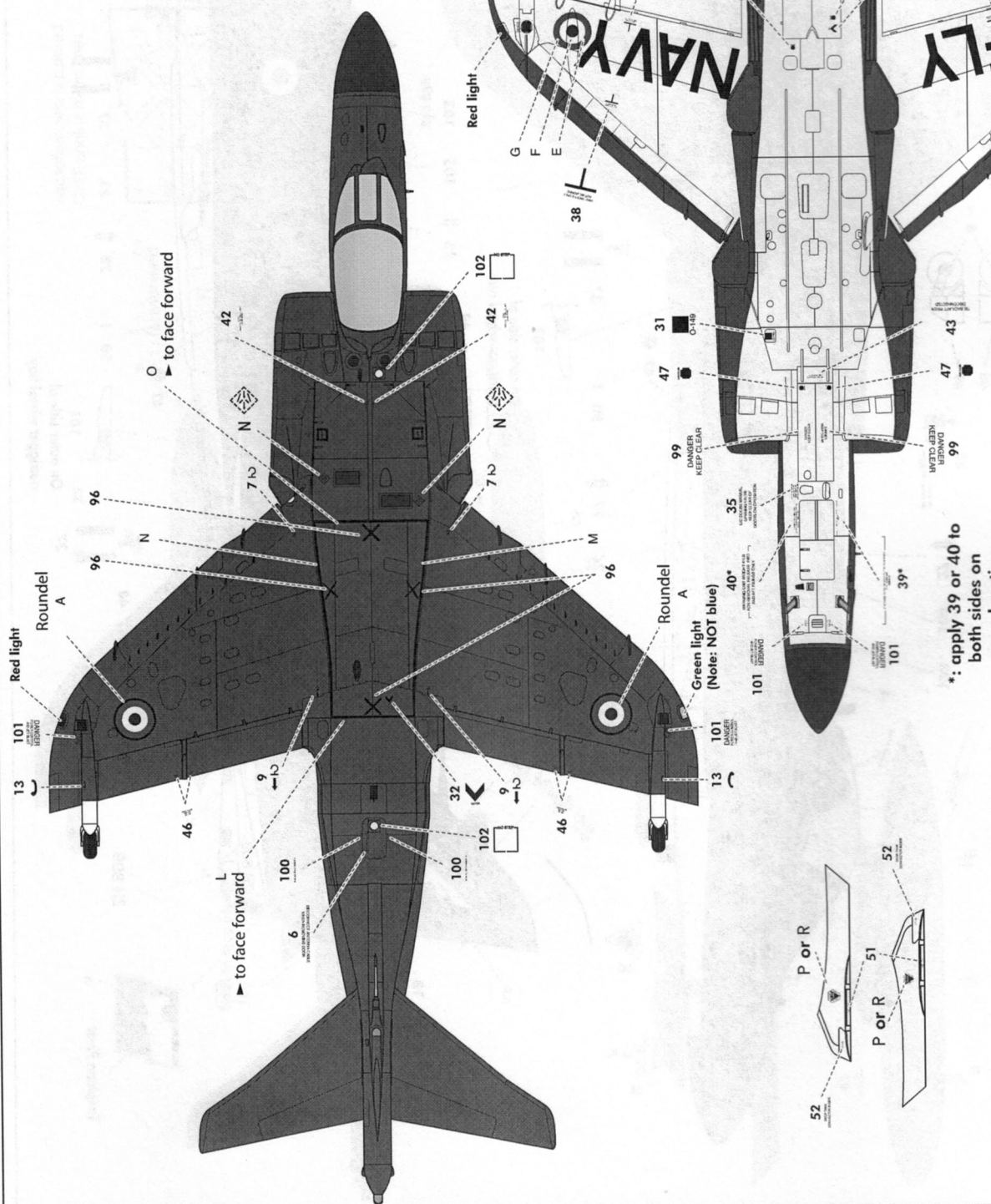

Note:
 1. Some picture shows no "Fly Navy"
 2. NO outer pylons have been attached
 to this aircraft

800 Squadron, Royal Navy, at disbandment, Yeovilton, 2004

Pilot Name Marking No. : "C" on both sides

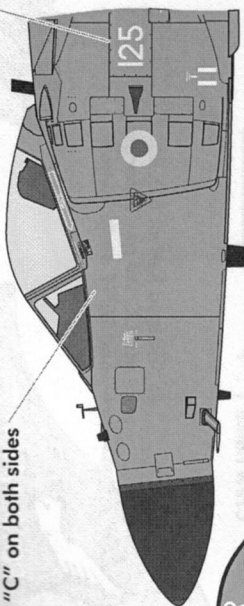

Aircraft No. : "A"

Aircraft Carrier Code : "D"

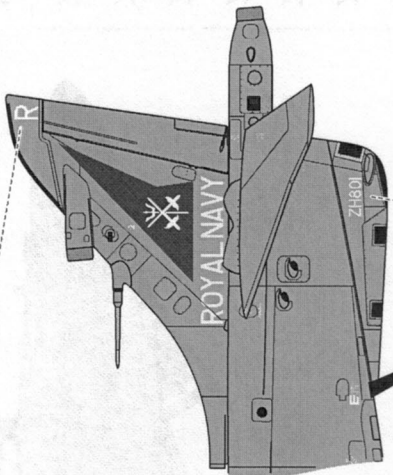

Aircraft Serial No : "B"

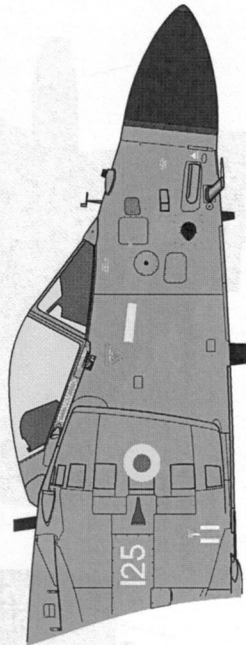

Last digit of Aircraft No. on outrigger gear door : "E"

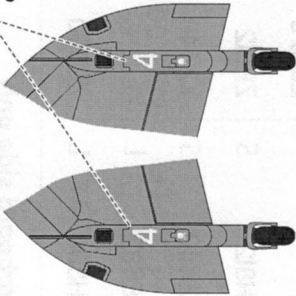

A	B	C	D	E
124	ZE696	4	16	4
125	ZH801	12	16	
126	ZD610	9	16	
127	ZH806	11	16	7
128	ZD579	6	16	8

Note: All aircraft carried gun pods and 190gal. tank only on the last flypast

801 Squadron, Royal Navy

Pilot Name Marking No. : "C" on both sides

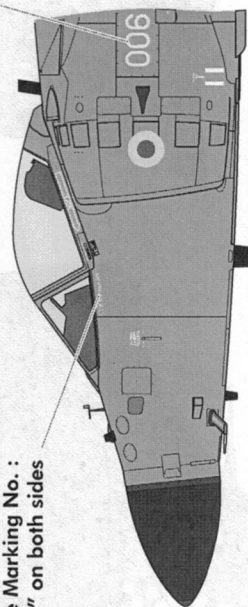

Aircraft No. : "A"

Aircraft Carrier Code : "D"

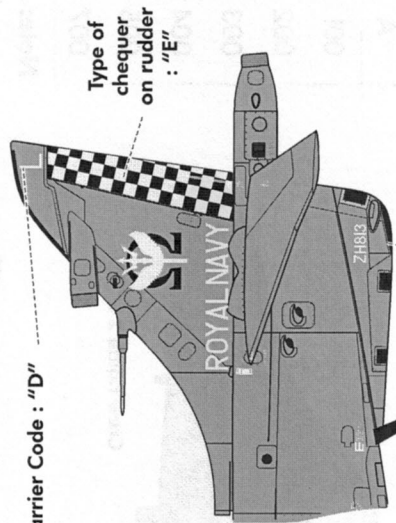

Type of chequer on rudder : "E"

Crew name 1 : "F"

Aircraft Serial No : "B"

Last HMS Illustrious Detachment, November, 2005.

A	B	C	D	E	F
001	ZH796	15	15	Y	
002	XZ440*	16	15	Z	
003	ZE690	18	15	Y	
004	ZH803	17	15	Z	25
005	ZH812	19	15	Z	
006	ZH813**	20	15	Y	

* : XZ440 is one of first SHAR built in 1979

** : ZH813 is the last SHAR FA.2 built in 1998

801 Squadron's disbandment, Yeovilton, March, 2006.

A	B	C	D	E	F	G
001	ZH796	2	15	Y	23	
002	ZH811	7	15	Y		24
003	ZH804	14	15	Y		
004	ZH803	5	15	Z	21	
005	ZH812	13	15	Z	27	
007	ZE690	11	15	Y		

Note: All aircraft carried fuselage strakes and AMRAAM drill rounds

899 Squadron, Yeovilton.

Oct, 2004.							Decommissioning, Mar, 2005.									
A	B	D	E	B	C	D	E	F	G	A	B	C	D	E	F	G
711	ZH802	L		ZH802	3				L							
712	ZH796	L		ZE692	8				L							
713	ZE690	S		ZH800	11				L	28						
714	ZE693	L														
715				ZD579	1	16	L	29								
716	ZH812	S		ZH812	3			S	27							
717	XZ440	S		XZ440	10			S								
718	ZE692	L														
719	ZH800	17	L	ZE690	33*			S								

***: On Starboard side only**

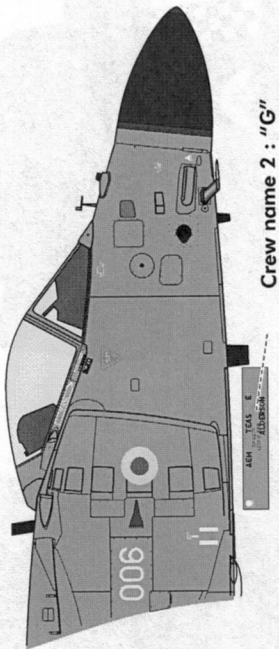
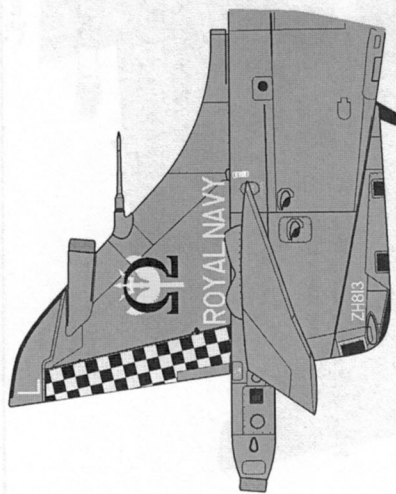

Crew name 2 : "G"

899 Squadron, Royal Navy

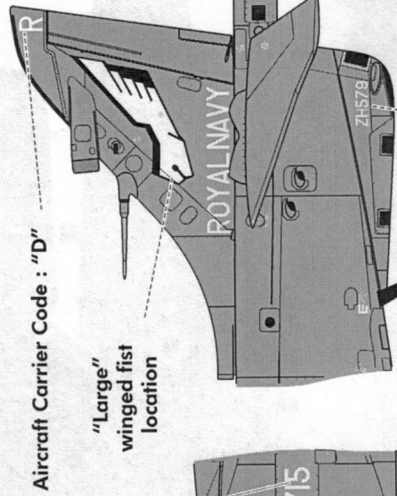

Aircraft Carrier Code : "D"

"Large" winged fist location

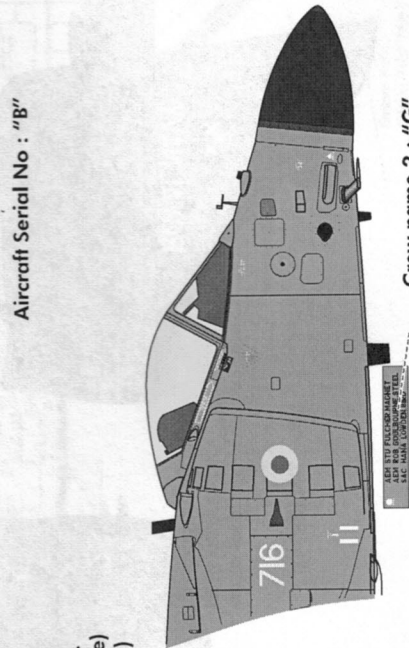

Aircraft Serial No : "B"

Crew name 2 : "G"

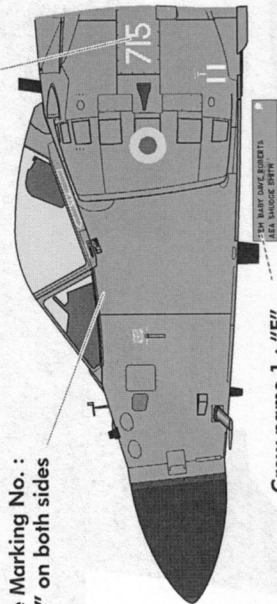

Aircraft No. : "A"

Pilot Name Marking No. : "C" on both sides

Crew name 1 : "F"

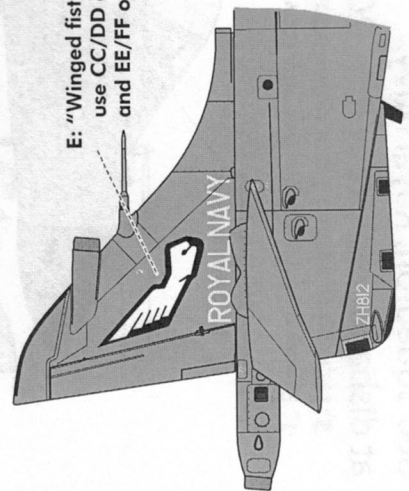

E: "Winged fist" of 899 Sq. use CC/DD on "L"(Large) and EE/FF on "S"(Small)