

11

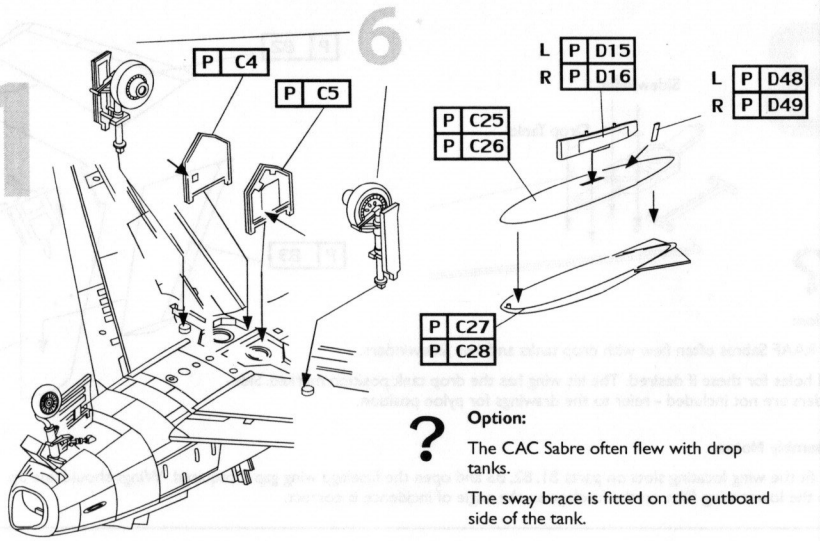

Option:
 The CAC Sabre often flew with drop tanks.
 The sway brace is fitted on the outboard side of the tank.

12

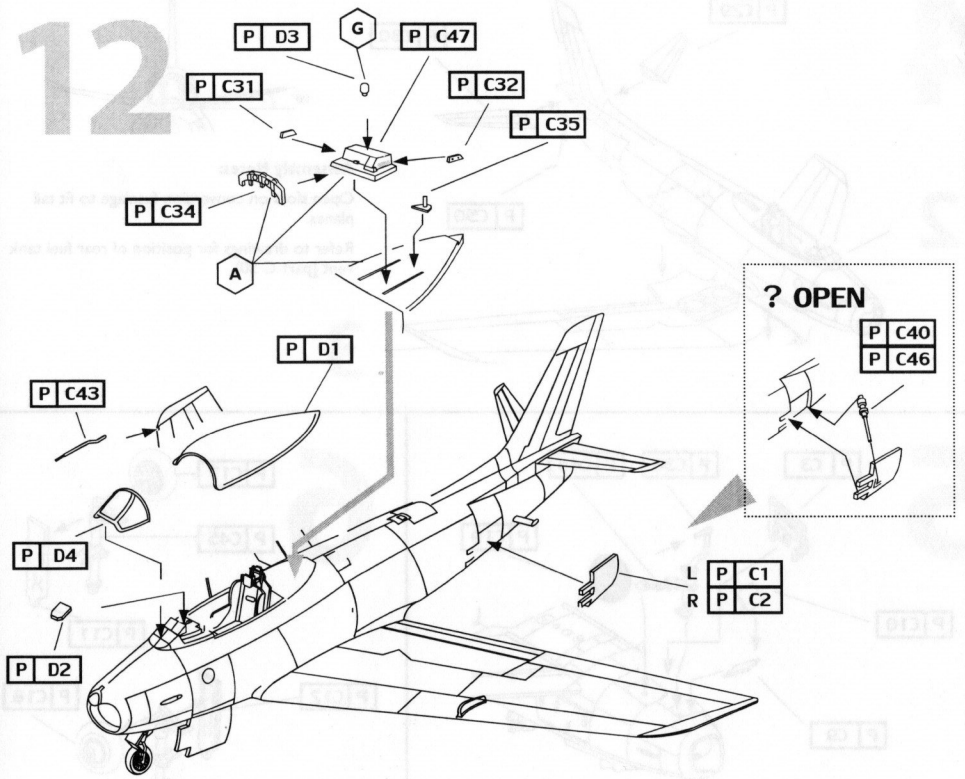

? OPEN



CAC CA-27 SABRE "AVON SABRE"

K 072078
 1/72 Scale Model Construction Kit

HISTORY

The CAC Avon Sabre was a unique aircraft in Australian military aviation history. It was the first all metal jet fighter to be constructed in this country. The decision to produce the North American Aviation (NAA) F-86 Sabre, fitted with the Rolls-Royce Avon turbo-jet engine and upgraded armament in the form of two ADEN cannons, saw CAC embark upon a major re-design program. Because the Avon engine was lighter, shorter and of greater diameter than the General Electric J34 engine which powered the NAA Sabre, CAC incorporated major structural changes in the Sabre fuselage, resulting in a total redesign of almost 40% of the fuselage.

The Avon Sabre gave sports car like performance as well as packing quite a punch. In service the aircraft proved to be versatile and although no trainer variant was produced in Australia pilot conversion proceeded with reasonable speed. As NAA produced modifications to the basic design these were incorporated in CAC built aircraft. The slatted wing was replaced with the famous 'six-three' wing. Sidewinder missiles were fitted to the aircraft and even ground attack missions were incorporated within the aircraft's repertoire.

The Sabre served operationally with 3, 75, 76, 77 & 79 Squadrons, and 2 OTU & 3 OCU between 1953-68. They were based in Australia and overseas, serving in Ubon, Thailand and Butterworth, Malaysia under mutual defence treaties. The survivors were then refurbished and supplied to the Indonesian and Malaysian Air Forces.

This kit includes a decal sheet from Souther Sky Models with schemes from 75 Squadron including the Black Diamonds display team.

COLOUR TABLE

KEY	COLOUR	SPECIFICATIONS	APPROXIMATE MATCH					
			GUNZE MR COLOR	HUMBROL	MODELMASTER	REVELL	TAMIYA	XTRACOLOR
A	BLACK		H12	33	1749	36302	XF-01	X404
B	POLISHED ALUMINIUM		C090	27002	1404	-	-	-
C	DARK GULL GRAY	FS 36231	H317	140	1740	36179	XF-54	-
D	LEATHER	-						
E	ALUMINIUM PAINT		H8	56	1781	32199	XF-16	-
F	STEEL		H18	53 27001	1780	32191	XF-56	-
G	CLEAR RED		H90	91321	4630	-	X-27	-
H	INSIGNIA RED	BSC 381 538	H327	153	1705		XF-07	
I	ORANGE		H14	18	-	-	X06	-
J	BRUNSWICK GREEN	BSC 381 226	H6	3	2049	32159	X-05	X7
K	LIGHT GREY	* BSC 381 C 630	-H315	-183	-	-	-XF-20	-
L	YELLOW	BSC 381 368	H329	24	1569	35115		X11

BEFORE YOU START

Wash all parts with dishwashing detergent and warm water to remove mould release agents.
 The conversion parts included in this kit have been produced using limited run injection moulding technologies. The mating edges will require adjustment before fitting. Careful preparation will result in an easier build.

CONSTRUCTION

Construction may require parts to be scratch built or sourced from a spares box. These are marked **S** and notes are given.

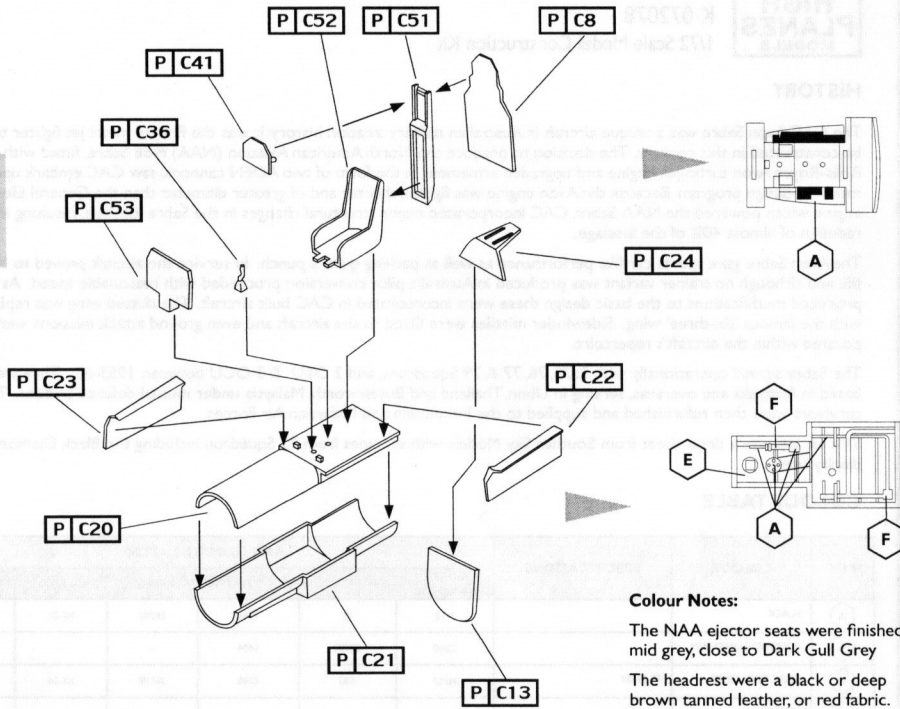

Colour Notes:
 The NAA ejector seats were finished in a mid grey, close to Dark Gull Grey
 The headrest were a black or deep brown tanned leather, or red fabric.

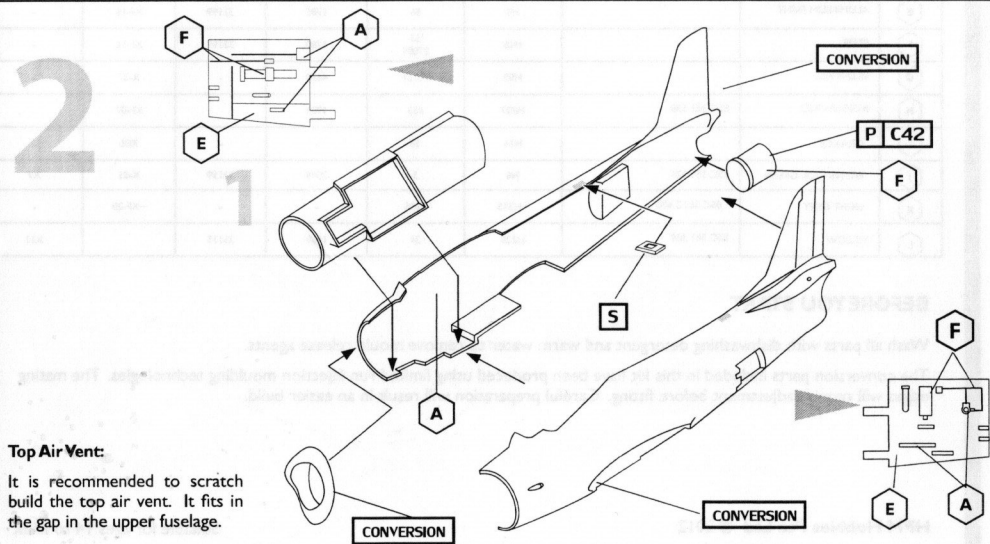

Top Air Vent:
 It is recommended to scratch build the top air vent. It fits in the gap in the upper fuselage.

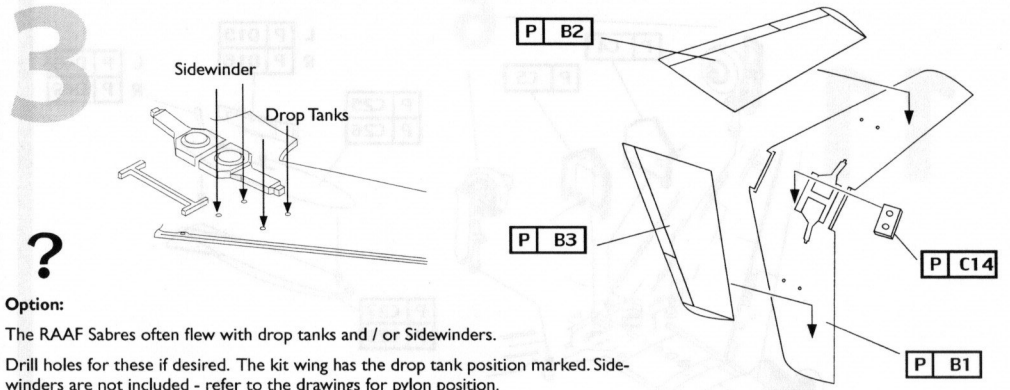

Option:
 The RAAF Sabres often flew with drop tanks and / or Sidewinders.
 Drill holes for these if desired. The kit wing has the drop tank position marked. Sidewinders are not included - refer to the drawings for pylon position.

Assembly Notes:
 Test fit the wing locating slots on parts B1, B2, B3 and open the fuselage wing gap if required. Wings should line up with the lower wing fillet on the fuselage so the angle of incidence is correct.

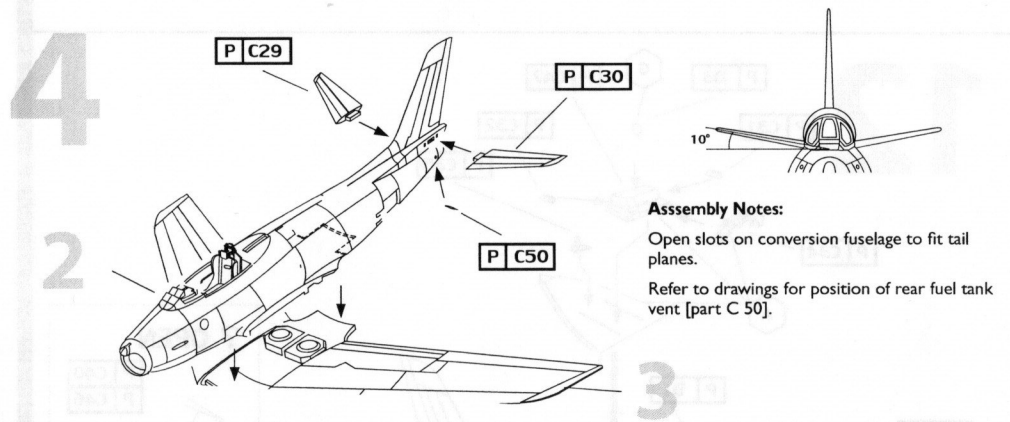

Assembly Notes:
 Open slots on conversion fuselage to fit tail planes.
 Refer to drawings for position of rear fuel tank vent [part C 50].

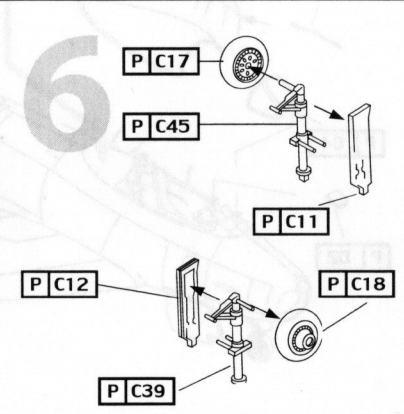
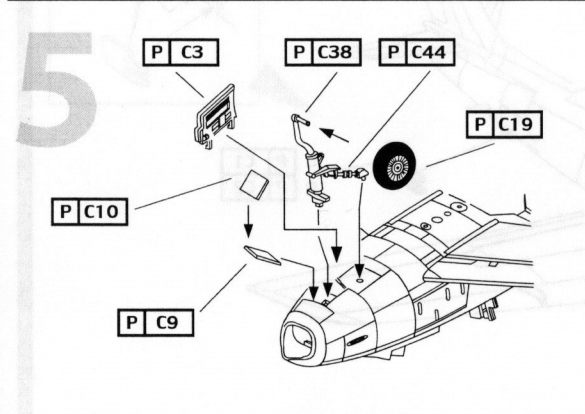

Royal Australian Air Force 75 Squadron Avon Sabre Mk32



SSM-035

Screen Printed

1/32	□	1/72	■
1/144	□	1/48	□

www.southernskymodels.com.au
LIMITED EDITION DECALS



Southern Sky Models



INSTRUCTIONS:

Applying the decals.

- 1 We recommended that you cut as close to the item as possible to achieve the best results from each decal.
- 2 When soaking in water you only need to soak them for a maximum of 11 seconds and then slide the item off the paper and straight on to the model.
- 3 Once on the model and in the right position, lightly press down on it with a dry tissue to soak up the excess water.
- 4 Once the decal has set and is dry you may then use some decal setting solution to help the decal adhere to the paint on the model.

Notes:

These decals are still raw and do not have a clear varnish finish on them.

This is to prevent them from cracking and turning yellow over time in storage.

How ever, there is a thin film of oil on them so before you apply any clear lacquer to them once they are on the aircraft we recommend that you give them a light wipe over with a soapy damp cloth. Then you can apply some clear acrylic lacquer to your model.

Warning: Be very gentle with the decal film when applying to the model. As the decal film is very thin and may tear if mistreated.

CAC Avon Sabre Mk32

75 Squadron RAAF Base Williamtown N.S.W.

Reference: Meteor, Sabre & Mirage in Australian service by: Stewart Wilson
North American (CAC) Sabre by: John Hopton
RAAF image archives (Canberra)

1.

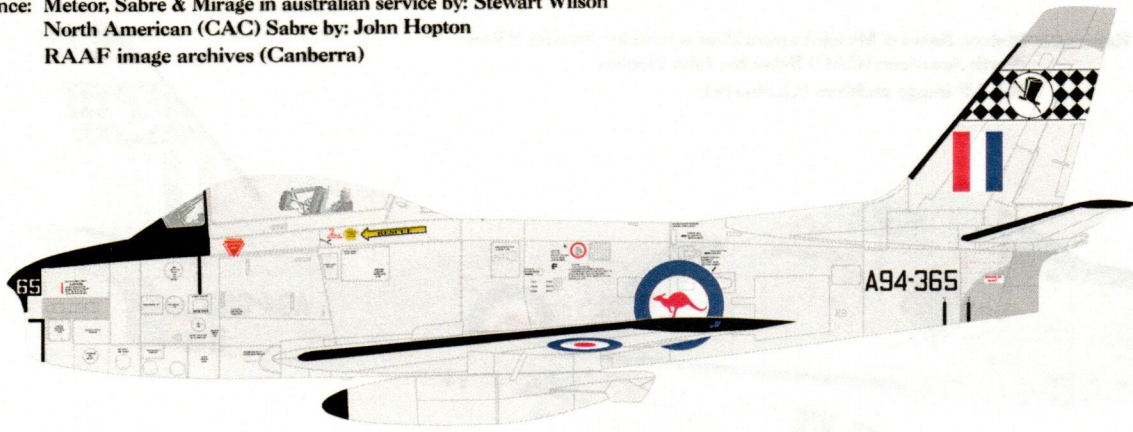

A94-365: This is one of the earliest paint schemes that 75 sqn carried on there sabre.
This aircraft was seen around RAAF Williamtown during the early 1960's

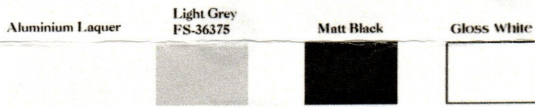
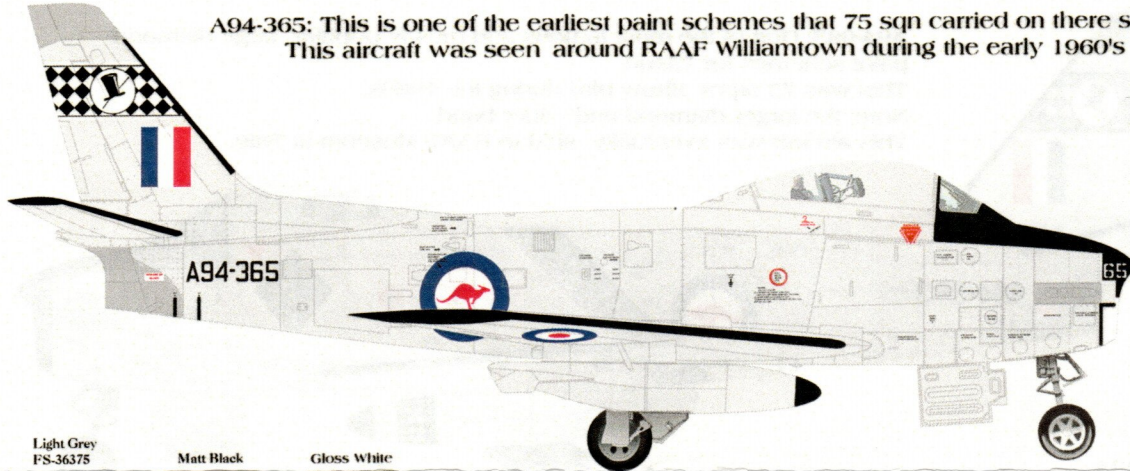

Exhaust covering and gun ports are polished metal

2.

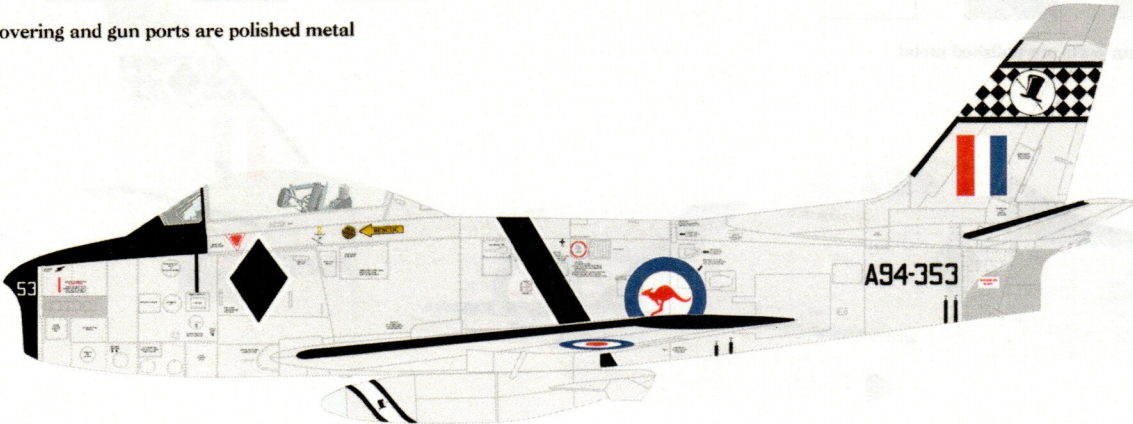

A94-353: This is one of the earliest large diamond paint schemes
that 75 sqn is most famous for.
This aircraft was seen around RAAF Williamtown during the mid 1960's

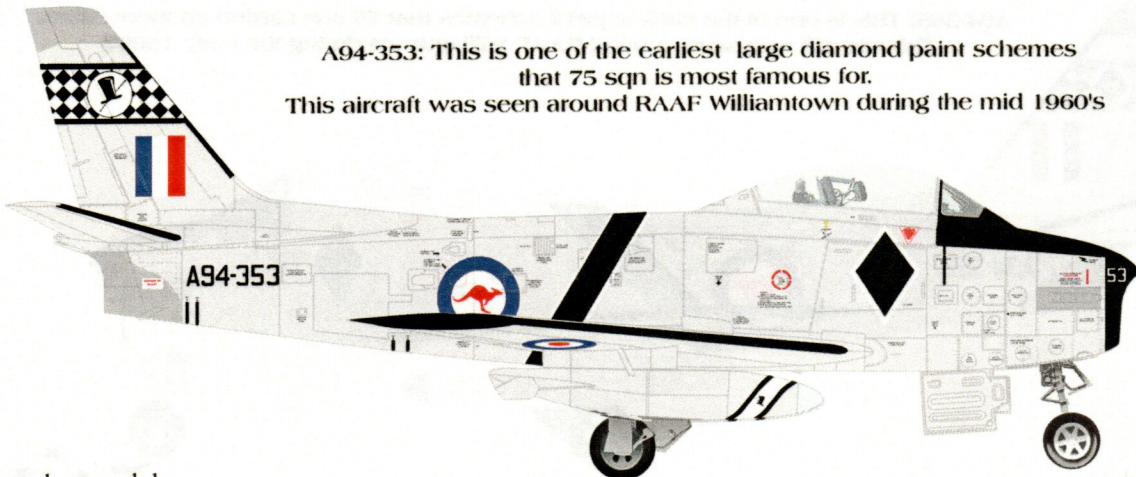

Drawings and research by:
Steven Evans
Drawings in 1/72 scale

SSM-035 75 SQN SABRE

Southern Sky Models

CAC Avon Sabre Mk32

75 Squadron RAAF Base Williamtown N.S.W.

Reference: Meteor, Sabre & Mirage in Australian service by: Stewart Wilson
North American (CAC) Sabre by: John Hopton
RAAF image archives (Canberra)

3.

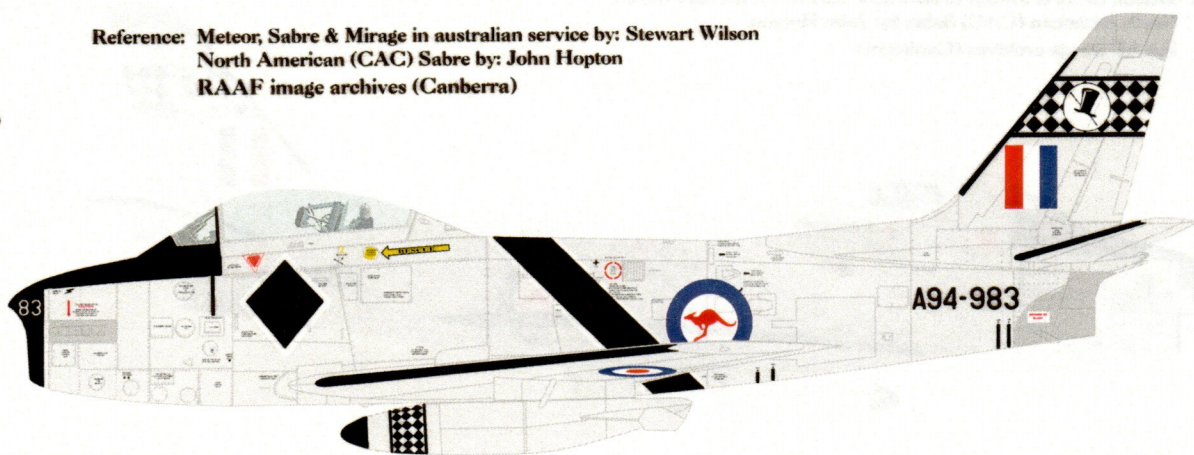

A94-983: One of the most famous and mostly popular large diamond paint schemes for 75sqn.
This was 75 sqn's Show bird during the 1980s.
Note: the larger diamond and wider band.
This aircraft was eventually sold to RAAF Museum at Sale.

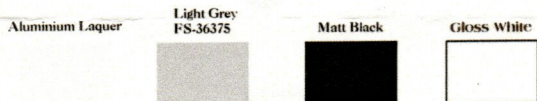
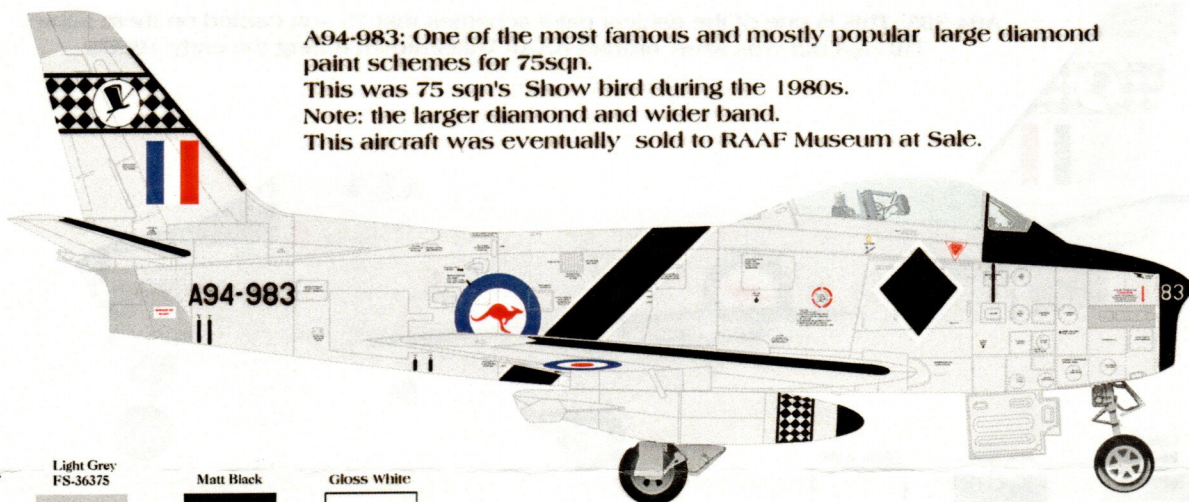

Exhaust covering and gun ports are polished metal

4.

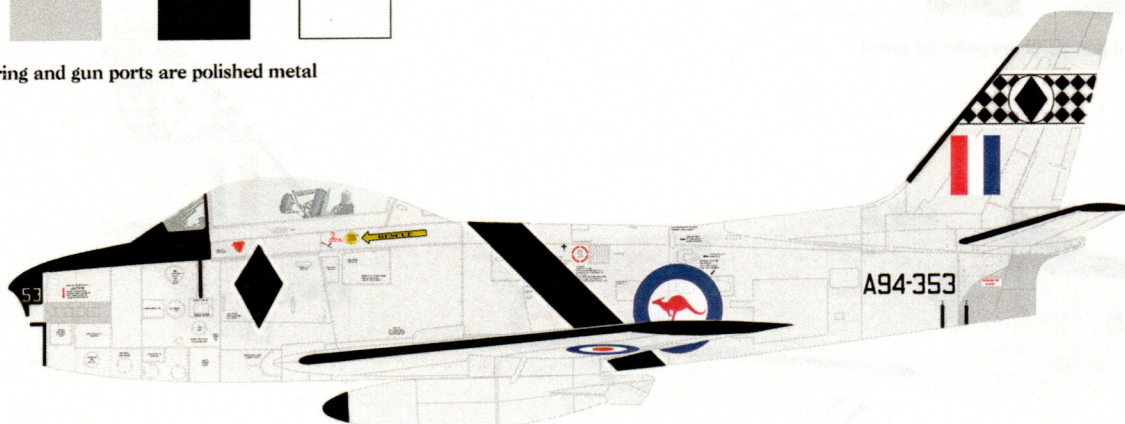

A94-365: This is one of the earliest paint schemes that 75 sqn carried on their sabre.
This aircraft was seen around RAAF Williamtown during the early 1960's

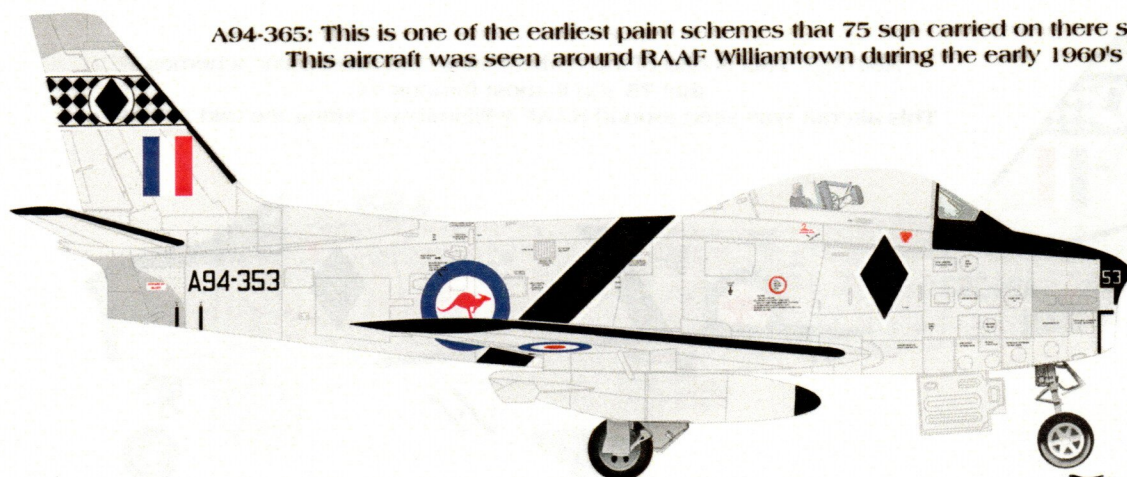

Drawings and research by:
Steven Evans
Drawings in 1/72 scale

SSM-035 75 SQN SABRE

Southern Sky Models

Aluminium Laquer Light Grey FS-36375 Matt Black Gloss White

Exhaust covering and gun ports are polished metal

CAC Avon Sabre Mk32

75 Squadron RAAF Base Williamtown N.S.W.

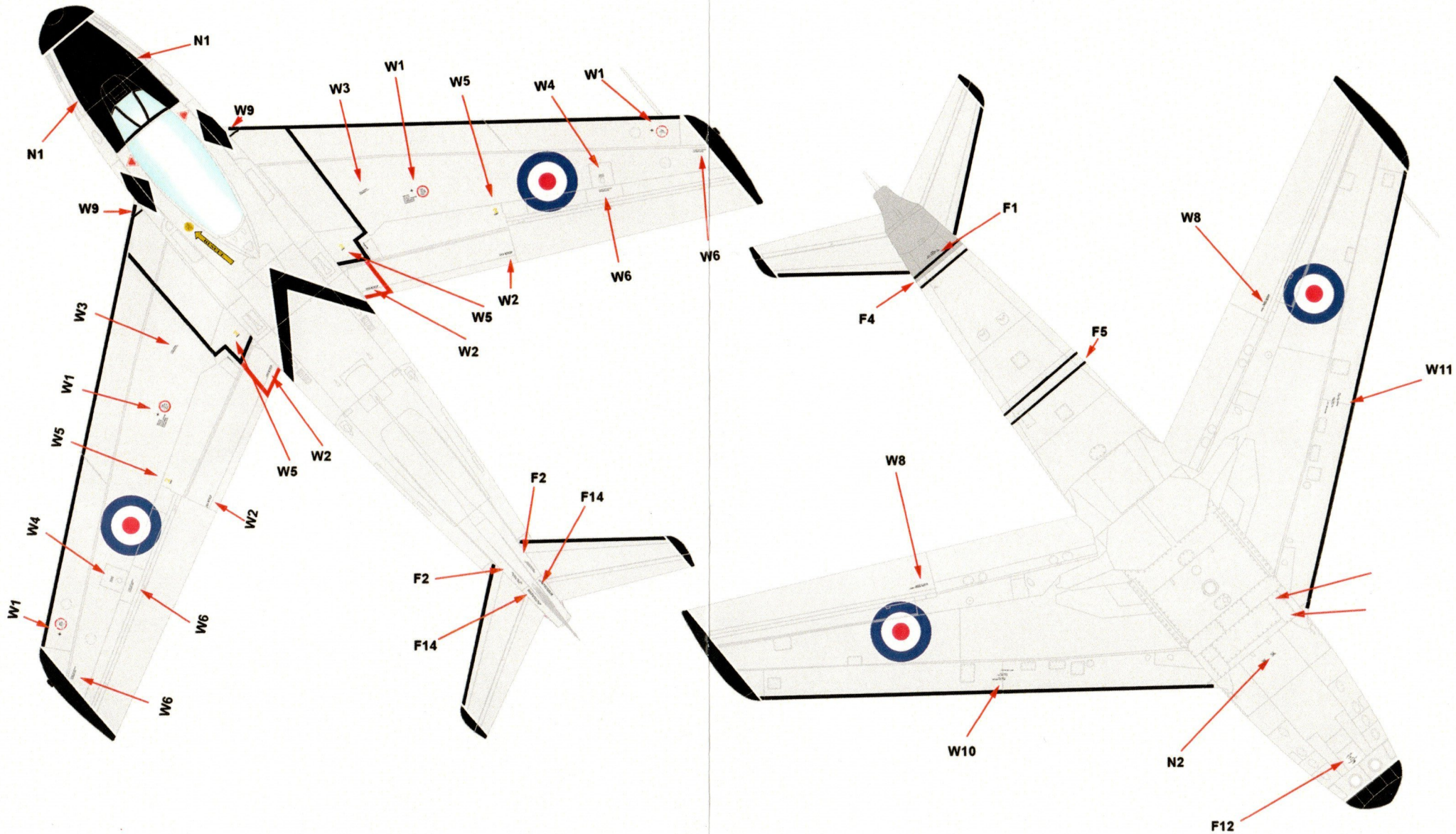

Drawings in 1/72 scale
by Steven Evans

Not all the minor data decals are available in the 1/72 scale set.