

ACADEMY

HOBBY MODEL KITS

P-51C MUSTANG "RED TAILS"

WITH GROUND VEHICLE

FA219/#2225

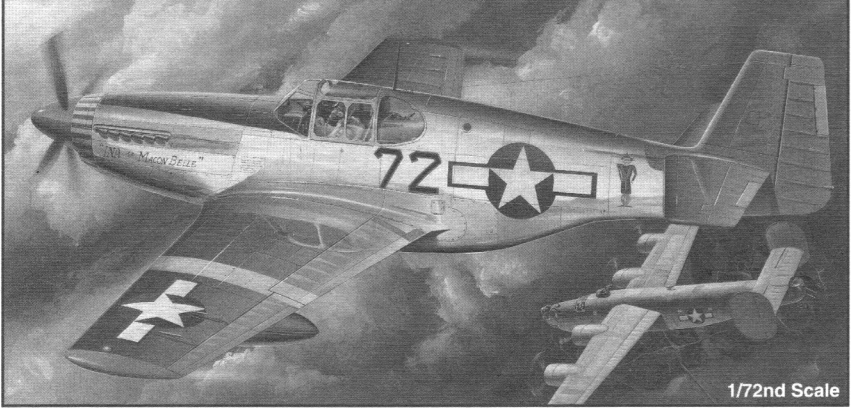

P-51C무스탕 "레드테일"

The P-51 Mustang earned its reputation as one of the greatest fighters of the Second World War, perhaps of all time. The replacement of the 1,100 hp Allison V-1710-39 engine in the original design to the Rolls-Royce Merlin engine brought the Mustang into the realm of excellence. This single seat fighter plane excelled with its deadly weaponry, high speed and long range maneuverability. This combination made the Mustang unparalleled as an escort fighter, interceptor and ground attacker, Also used for reconnaissance missions the Mustang proved its worth by staying active around the world well into the seventies.

Die P-51 Mustang verdient es, als eines der großartigsten Jagdflugzeuge aller Zeiten bezeichnet zu werden, vielleicht sogar als das Beste. Die anfänglichen Probleme mit dem 1100 PS Allison V-1710-39 Motor verschwanden nach dem Einbau des Rolls-Royce Merlin Triebwerkes und die Mustang begann ihre steile Karriere. Der einsitzige Jäger bestach durch seine gewaltige Feuerkraft, hohe Geschwindigkeit und Reichweite. Diese Kombination befähigte die Mustang zu Begleit-, Jagd- und Bodenangriffseinsätzen mit unvergleichlichen Ergebnissen. Sie wurde ebenso als Aufklärer verwendet und bewies ihren Wert bis ans Ende ihrer Dienstzeit in den siebziger Jahren.

P-51 무스탕기는, 多分第2次世界大戦時の全期を通じて、もっとも偉大な戦闘機の中の一つの飛行機としての名声を獲得しました。原型機で装備された1100馬力のアリソン V-1710-39型エンジンからロールス・ロイス・マーリン・エンジンへの改装で、ムス탕機は傑作機の域に達しました。この単座戦闘機は、優れた武装量、高速度および長距離航続能力などの運用性能に秀でていました。これらの長所の組み合わせがムス탕機を、護衛戦闘機、迎撃戦闘機および対地攻撃機として比類なき戦闘機たらしめたのです。また、ムス탕機は、偵察任務にも使用され、70年代に至るまで世界中で現役機としてとどまり続けたことで、その価値を立証したのです。

P-51 무스탕기는 아마도 제2차 세계대전 전 기간을 통틀어 보아도 가장 뛰어난 활약을 펼쳤던 위대한 전투기중의 하나라 해도 틀림 없을 것이다. 당초 앨리슨사제의 V-1710-39형 엔진을 장비하고 있던 무스탕의 원형기는 이 엔진이 지닌 고질적인 고고도성능 부족문제에 지적됨에 따라 새로이 영국제 로스 로이스 멀린엔진(후에 패커드 멀린엔진으로 라이센스 생산)을 도입, 장착하게 되는데, 이 개수작업에 의해 잠재된 성능을 100% 발휘할 수 있게된 무스탕은 비로서 걸작기의 반열에 오르게된다. 단발엔진의 단좌형 전투기임에도 불구하고 우수한 무장탑재량과 뛰어난 고속성능 및 장거리 항속능력을 지닌 무스탕은, 이러한 장점을 최대한 살려 대전기간중 호위, 요격임무는 물론 지상공격기나 정찰기로서도 맹활약을 펼쳤으며, 상당수의 기체는 1970년대까지도 살아남아 세계 곳곳에서 현역기로 쓰일만큼 그 뛰어난 성능을 입증하였다.

<READ THIS BEFORE YOU BEGIN>

- Study the instructions before assembling.
- Check the fit of each piece before cementing into place.
- Do not use too much cement to join parts.
- Never use cement of paint near open flame.
- Open a window or make area well ventilated when cement of paint is in use.
- Tear up and throw away the empty plastic bags to avoid danger of suffocation for little children.

<ALLGEMEINE HINWEISE>

- Die Anordnung der Bauteile ist aus den Zeichnungen der Anleitung ersichtlich.
- Die Teile vor dem Verkleben ungeleimt zusammenhalten, um innen passizz zu prüfen.
- Klebstoff nicht zu dick auftragen.
- Klebstoff und Farben niemals in der Nähe einer Flamme verwenden.
- Während der Bemalung mit Spritzpistole oder Pinsel für frische Luftzufuhr, Z.B. öffnen des Fensters, sorgen.
- Bausatz von Kleinen Kindern fernhalten. Verhüten Sie, daß Kinder irgendwelche Bauteile in den Mund nehmen oder Plastiktüten über den Kopf ziehen.

<LISEZ CE QUI SUIT AVANT DE COMMENCER LE MONTAGE>

- Etudier les schémas d'assemblage.
- Contrôler que chaque pièce soit bien conforme avant de la coller à sa place.
- N'utilisez pas trop de colle pour réunir les pièces.
- Ne faites manipuler la colle ou peinture à proximité d'une flamme.
- Aérer soigneusement la pièce où vous peignez/ouvrez la fenêtre).
- Après avoir sorti les pièces du sac en plastique, déchirer le sac afin d'éviter que les enfants ne le mettent sur la tête et ne s'étouffent.

■ 組み立てる前に

- 組み立てる前に説明書をお読み下さい。
- 部品をランナーから切りはなす時は模型用ニッパーとカッターを使用します。
- 接着剤を少し少なめに使うことがきれいに仕上げるコツです。
- 接着する前に部品を合わせて確かめます。
- 接着剤や塗料を使用する時はときどき窓を開けて換気に気をつけましょう。
- 組み立て後の部品やビニール袋は小さな子供の手の届かない安全な所に保管して下さい。

■ 조립하기 전에

- 부품을 조립하기 전에 설명서를 잘 읽어본 후 조립한다.
- 부품을 자를 때에는 칼이나 니퍼로 깨끗이 잘라준다.
- 접착제를 사용할 곳과 사용하지 않는 곳에 주의하고 너무 많이 바르지 않도록 한다.
- 접착하기 전에 부품을 맞추어 확인한 후 조립한다.
- 에나멜 페인트나 접착제를 사용할 때는 창문을 열어 환기를 시키고 화기를 멀리한다.
- 사용 후 남은 부품은 어린 아이들의 손에 닿지 않도록 잘 처리한다.

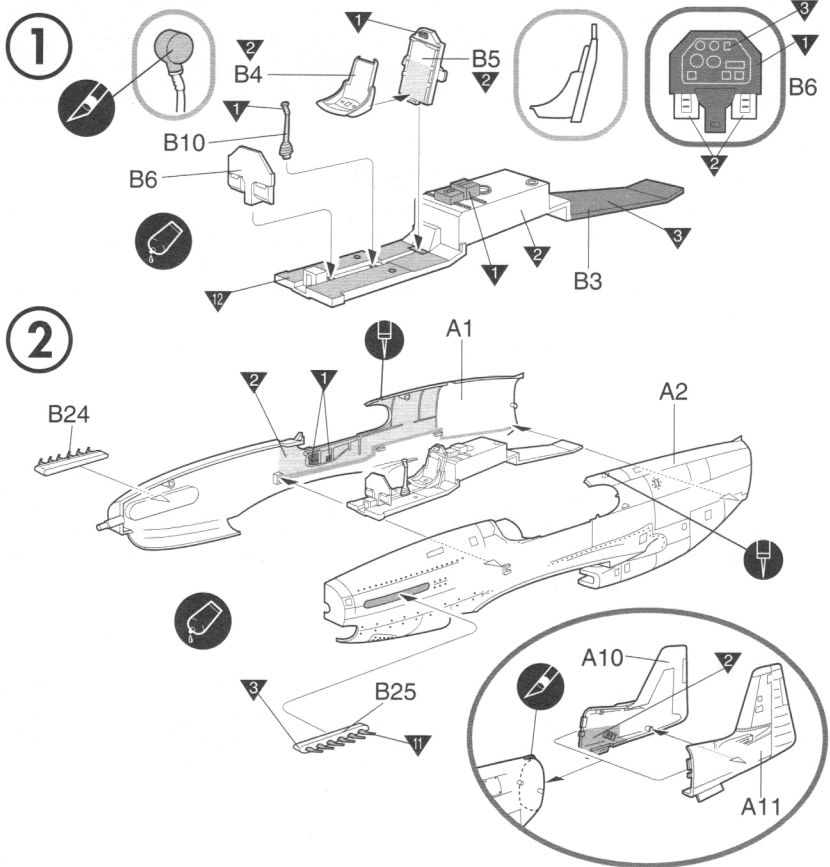

<p>점착한다 Cement Parts Coller Kleben Pegar Incollare Colar Kleben</p>	<p>점착하지 않는다. DO NOT cement Ne pas coller Nicht kleben No pegar Non incollare Nao colar Niet kleven</p>	<p>2 반대측도 조립한다 Repeat for opposite side Répétition de la page Wiederholung für gegenüberliegende Seite</p>	<p>☆ 전사지를 붙인다. Decals/comanies Abziehbild</p>	<p>g 무게추를 넣는다. Add weight Laster Gewicht</p>
<p>잘라낸다. Cut away Couper schneiden Cortar Tagliare Cortar Snijden</p>	<p>선택한다. Optional parts Choix Auswahlmöglichkeit Eleccion Scelta Opcao Keuze</p>	<p>반대측도 조립한다 Repeat for opposite side Répétition de la page Wiederholung für gegenüberliegende Seite</p>	<p>구멍을 뚫어준다. Make hole Faire un trou Offnen</p>	<p>주의한다. Be careful Faire attention Hier vorsicht</p>

3

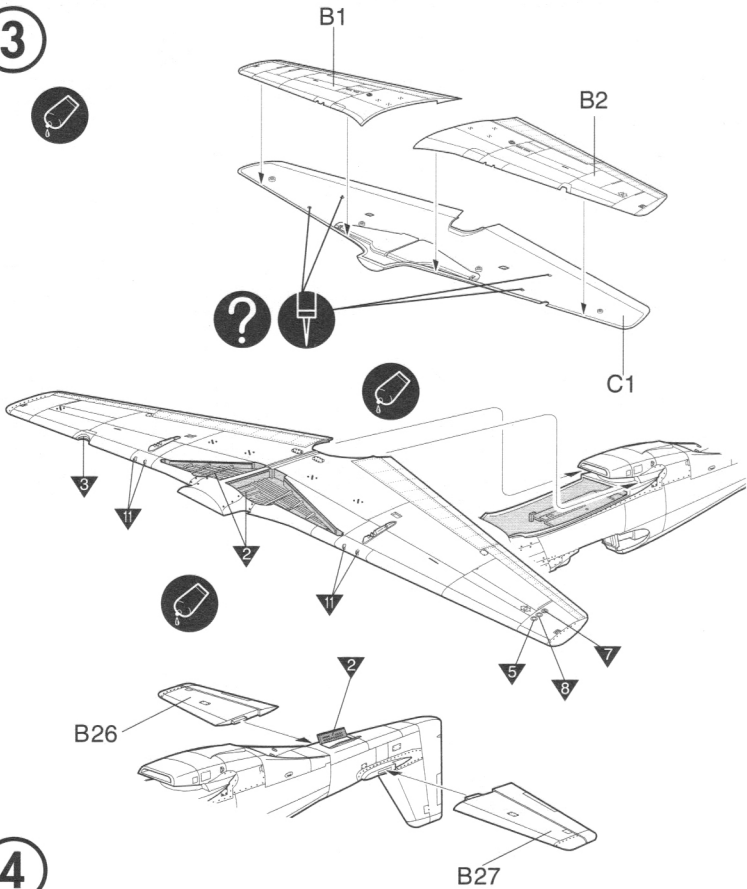

4

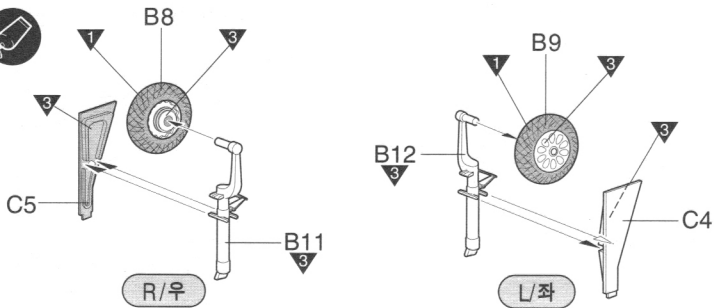

구멍이나 홈을 채워준다.
Use filler
Mastiquer
Schießen



색칠 및 건조지 표시 번호
Painting scheme number
Numeros de la lista de pinturas
Lackeschemanummer

- 1 FLAT BLACK
- 2 INTERIOR GREEN
- 3 SILVER
- 4 YELLOW
- 5 CLEAR RED

- MATTSCHWARZ
- INNENGRÜN
- SILBER
- GELB
- ROT, REIN

- NOIR MAT
- VERT INTERIEUR
- ARGENT
- JAUNE
- ROUGE CLAIR

- つや消しブラック
- インテリアグリーン
- シルバー
- イエロー
- クリアーレッド

- 무광 검정색
- 인테리어 그린
- 은색
- 유광 노랑색
- 클리어 레드

5

Attach as shown.
Gemäß Abbildung einbauen.
Fixer comme indiqué.
図の角度でとりつけます。
그림의 각도처럼 조립한다.

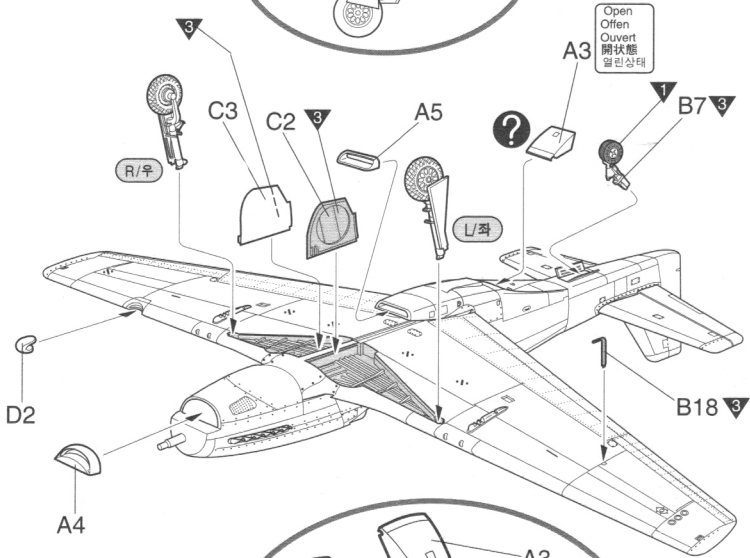
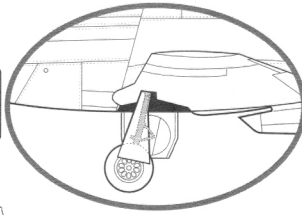

Open
Ouvert
Ouvvert
開状態
열린상태

Closed
Geschlossen
Fermé
閉状態
닫힌상태

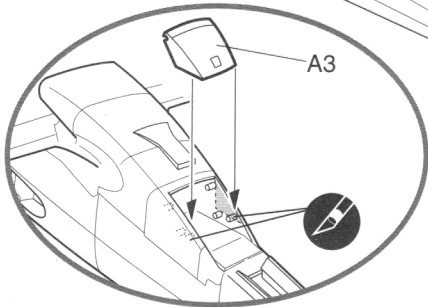

6

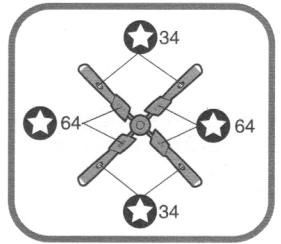
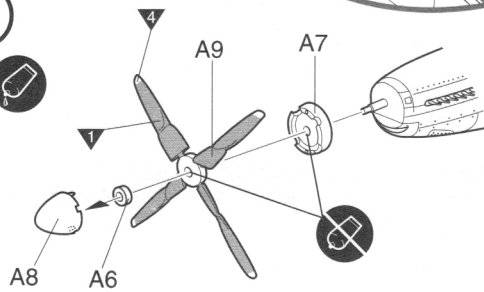

6	CLEAR BLUE	BLAU, REIN	BLEU CLAIR	クリアーブルー	클리어 블루
7	CLEAR ORANGE	ORANGE, REIN	ORANGE CLAIR	クリアーオレンジ	클리어 오렌지
8	CLEAR GREEN	GRÜN, REIN	VERT CLAIR	クリアーグリーン	클리어그린
9	OLIVE DRAB	BRAUNOLIV	BRUN OLIVE	インテリアグリーン	국방색
10	RED	ROTHELLBRAUN	ROUGE BRUN CLAIR	レッド	유광 빨강색

7



Closed
Geschlossen
Fermé
閉状態
닫힌상태

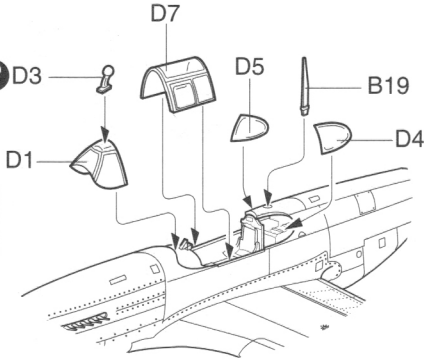

Open
Offen
Ouvert
開状态
열린상태

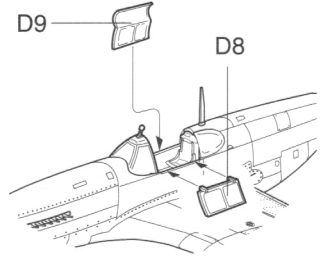

8



4.5in. ROCKET BAZOOKA
4.5인치 로켓 바주카

9 C6(C16)

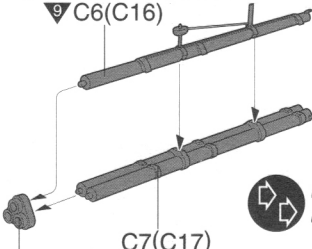

9 C8(C15)

C7(C17)



500lb. BOMB
500파운드 폭탄

9 C9(C11) C13(C14) 9

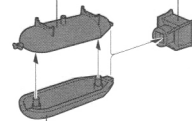

C10(C12) 9



108gal. REINFORCED PAPER
DROP TANK
강화종이제 108갤런 연료탱크



C18(C20)



75gal. DROP TANK
75갤런 연료탱크

B13(B15)

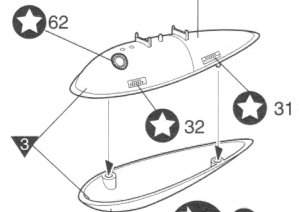

B14(B16)



11 GUNMETAL

METALL-GRAU

GRIS ACIER

ガンメタル

건메탈

12 LIGHT BROWN

HELLBRAUN

BRUN CLAIR

ライトブラウン

라이트브라운

8

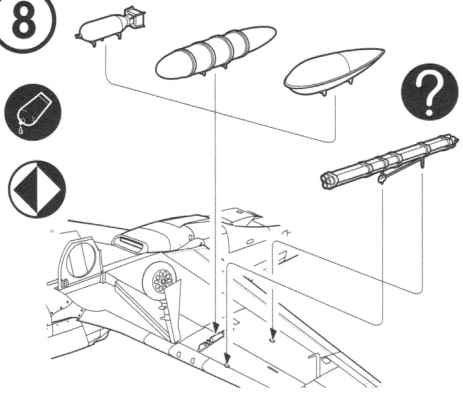

1

LIGHT UTILITY VEHICLE
다용도 차량

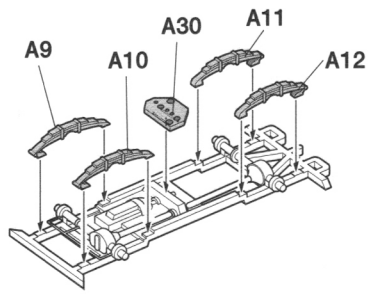
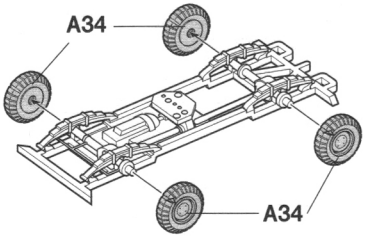
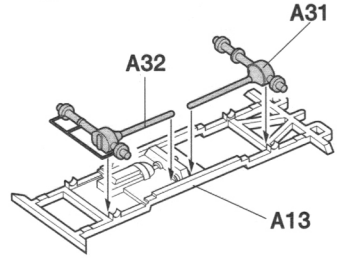

2

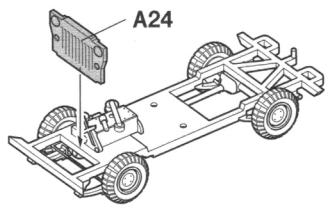
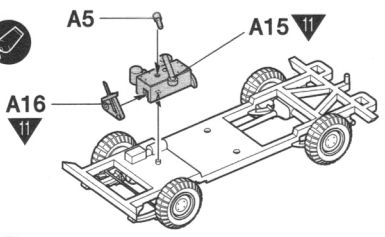

3

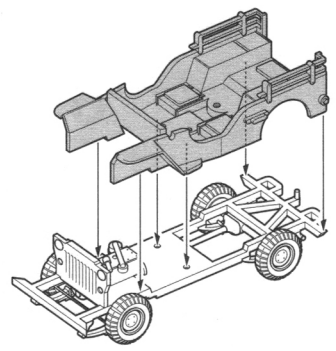
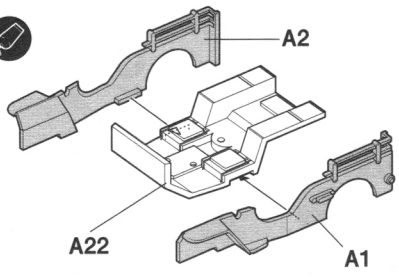

4

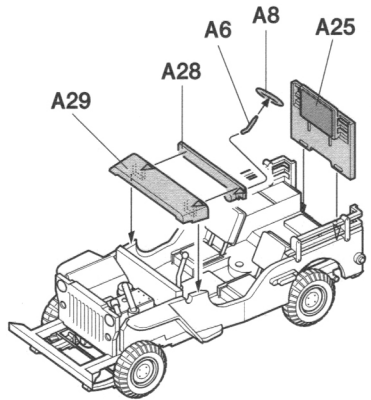
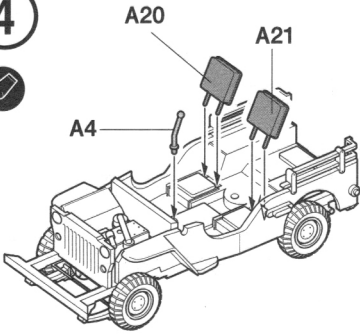

5

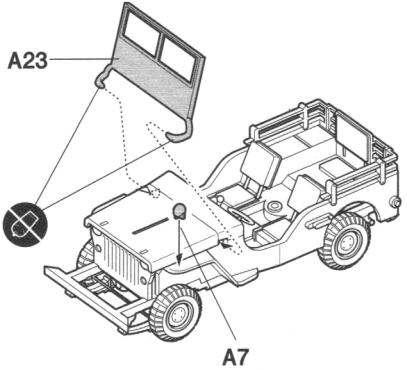
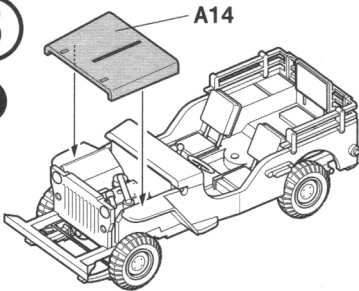

6

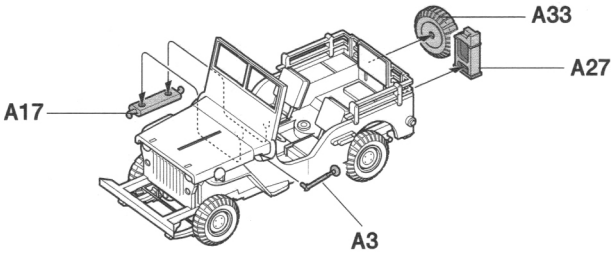

Painting & Decal placement 색칠 및 전사지 붙이기

1 LIGHT UTILITY VEHICLE
다용도 차량

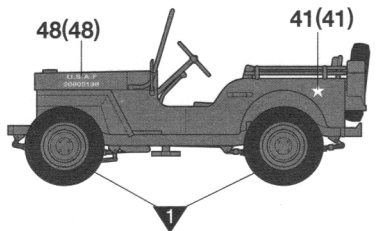
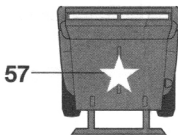
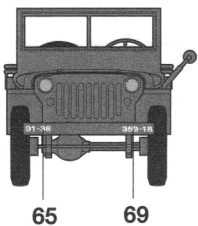

Parts Locating Diagram 부품도

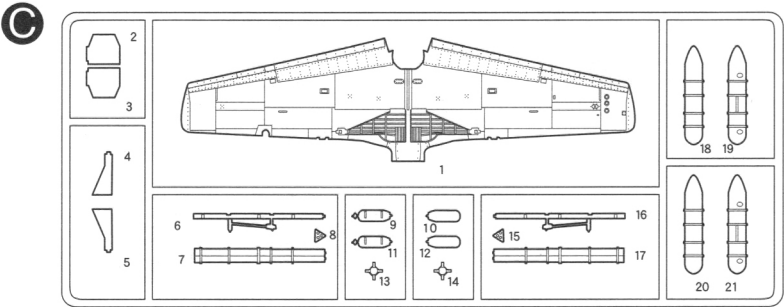
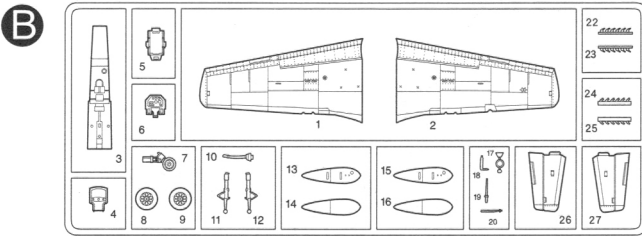
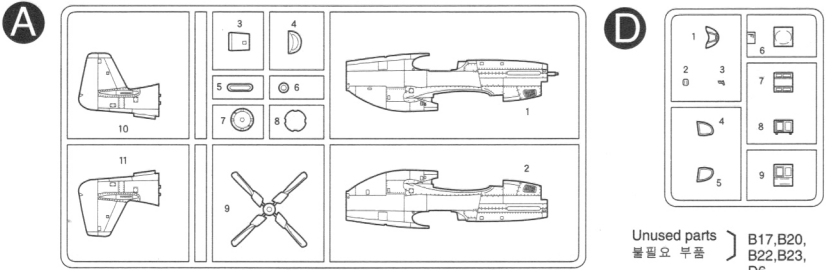

A LIGHT UTILITY VEHICLE 다용도 차량

Unused Parts 불필요부품 : A18, A19, A26

