



МиГ-25РБ

Советский самолет-разведчик

В конце 60-х годов в ОКБ А. И. Микояна был разработан первый в мире истребитель-перехватчик со скоростью полета 3М – МиГ-25.

В это же время был сконструирован высотный разведчик-бомбардировщик, получивший название МиГ-25РБ.

Эти не имеющие аналогов самолеты-разведчики состояли на вооружении ВВС СССР (впоследствии – России), а также экспортировались в Ирак и Сирию. МиГ-25РБ ВВС Ирака использовались для бомбовых ударов во время Ирано-Иракской войны 1980-1988 г.

Тактико-технические характеристики МиГ-25РБ

Длина, м.....	21,55
Размах крыла, м.....	13,42
Взлетный вес (нормальный), кг.....	37100
Двигатели.....	2хТРДФ Р15БД-300, тяга на форсаже – 2х11200 кгс
Максимальная скорость, км/ч.....	3000
Потолок, м.....	23000
Дальность, км.....	1865 / 2400 с ПТБ
Вооружение.....	до 4000 кг бомб

ВНИМАНИЕ!

Перед сборкой внимательно прочитать руководство по монтажу. Каждая деталь пронумерована. Соблюдать последовательность монтажа. Необходимые рабочие инструменты: нож и напильник для зачистки деталей; резиновая лента, клейкая лента и зажимы для сушки белья для прижимания склеиваемых деталей. Детали из пластика очистить в растворе мягкого моющего средства и высушить на воздухе для того, чтобы краска и переводные картинки лучше прилипали. Перед приклеиванием проверить, подходят ли детали; клей наносить экономно. Хром и краску удалить с поверхностей склеивания. Небольшие детали покрасить перед тем, как они будут удалены из рамок. Краску необходимо хорошо просушить, только после этого продолжать сборку. Каждую соответствующую переводную картинку отдельно вырезать и примерно на 20 секунд окунуть в теплую воду. На обозначенном месте картинку отделить от бумаги и прижать промокающей бумагой.

MiG-25RB

Soviet Reconnaissance Plane

In the end of 60s the Mikoyan Design Bureau was developed the world's first interceptor fighter with speed of Mach 3 – the MiG-25.

At the same time high reconnaissance-bomber modification was designed, which was called the MiG-25RB.

These perfect reconnaissance planes served in Soviet (later – Russian) Air Force, and were delivered to Iraq and Syria. MiG-25RB Iraqi Air Force was used for bomb attacks during the Iran-Iraq war of 1980-1988.

Tactical and Technical Specifications of MiG-25RB

Length, m.....	21,55
Span, m.....	13,42
Start weight (normal), kg.....	37100
Engines.....	2xR15BD-300, thrust in afterburner - 2x11200 kgf
Max. Speed, km/h.....	3000
Service ceiling, m.....	23000
Range, km.....	1865 / 2400 with drop tank
Armament.....	Bomb load - up to 4000 kg

CAUTION!

Read the instructions thoroughly prior to assembly. Each component is numbered. Adhere to specified sequence of assembly. Tools required: knife and file for removal of components from frame; rubber bond, adhesive tape and clothes pegs for clamping components together after applying adhesive. Clean plastic components in a mild detergent solution and allow to air-dry so that paint and transfers adhere better. Prior to applying adhesive, check to see whether the components fit together; apply adhesive sparingly. Remove chrome and paint from the contact surfaces. Paint small components before removing them from the frame. Allow paint to dry well, and only then continue to assemble. Cut out each transfer individually and immerse in warm water for approx. 20 seconds. Slide transfer off paper and into designated position, then press on with blotting paper.

ИСПОЛЬЗУЕМЫЕ КРАСКИ / USED COLORS:

	Revell	Tamiya		
A	371	XF80	Светло-серый, полуматовый	Light Grey
B	169	XF75	Темно-серый, матовый	Dark Grey
C	108	XF1	Черный, матовый	Flat Black
D	190	X11	Полированная сталь	Chrome Silver
E	191	X32	Сталь	Steel
F	195	X31	Титан	Titanium Gold

	Revell	Tamiya		
G	199	XF16	Алюминий	Aluminium
H	364	XF5	Зеленый, матовый	Flat Green
J	148	XF71	Сине-зеленый, матовый	Blue Green
K	157	XF20	Серый, матовый	Medium Grey
L	161	X25	Зеленый, глянцевый	Clear Green
M	731	X27	Красный, глянцевый	Clear Red

01 СТАДИЯ СБОРКИ
ASSEMBLY STEP

x2 СДЕЛАТЬ ДВЕ ДЕТАЛИ
MAKE 2 PCS

■ ПРИ СБОРКЕ НЕ ИСПОЛЬЗУЕТСЯ
PARTS NOT FOR USE

***** СДЕЛАТЬ САМОМУ
SCRATCH BUILD

03 СБОРОЧНАЯ ЕДИНИЦА
ASSEMBLY UNIT

A ИСПОЛЬЗУЕМАЯ КРАСКА
USED COLOR

□ ПРОСВЕРЛИТЬ
OPEN HOLE

? ПРОИЗВОЛЬНЫЙ ВЫБОР
OPTIONAL

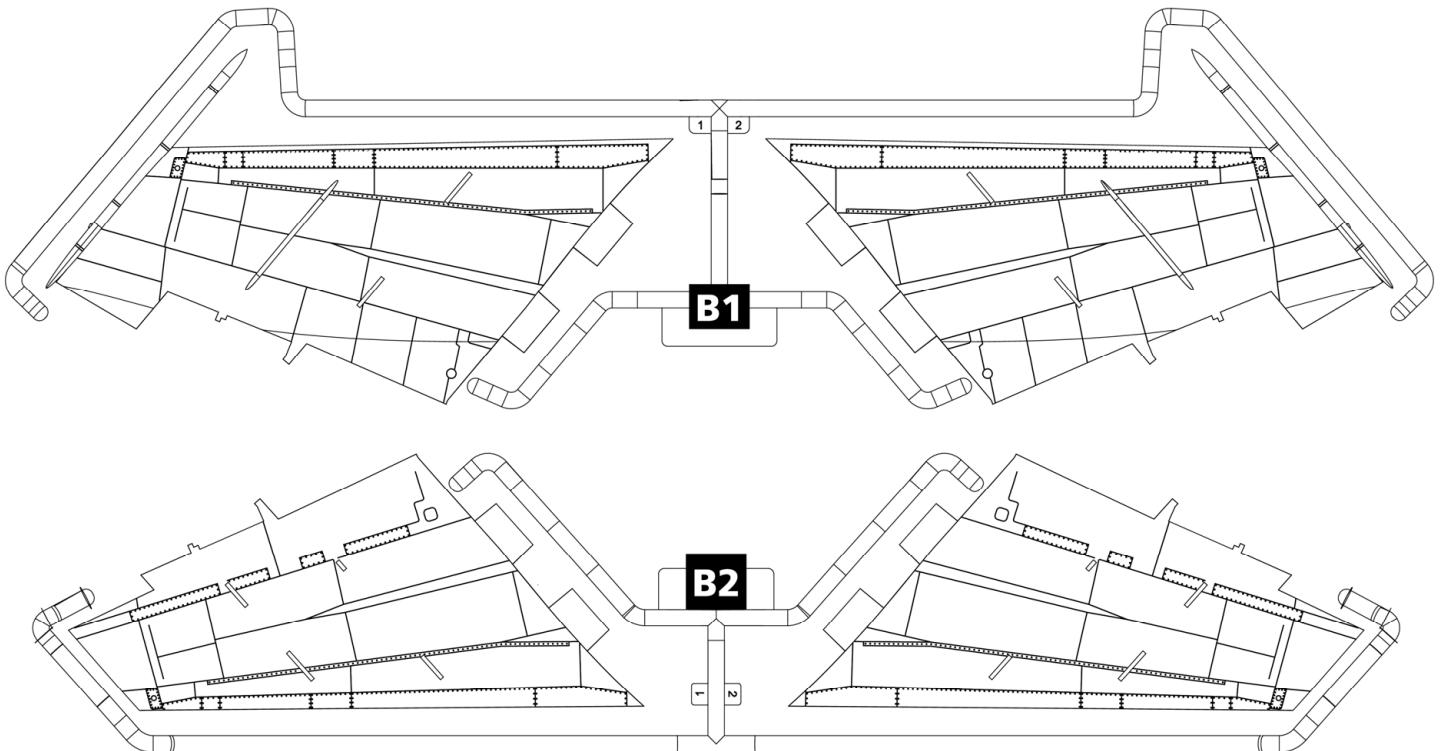
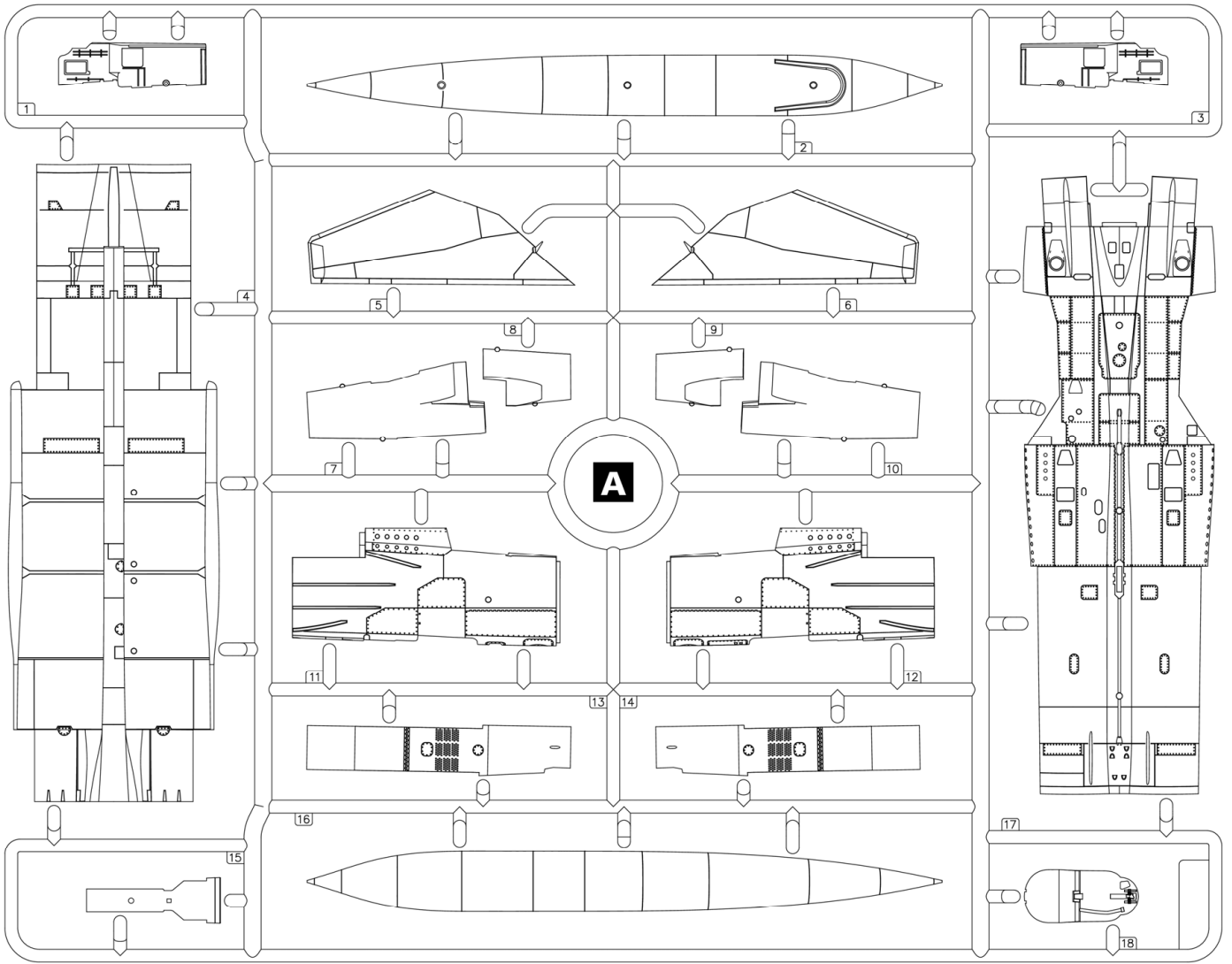

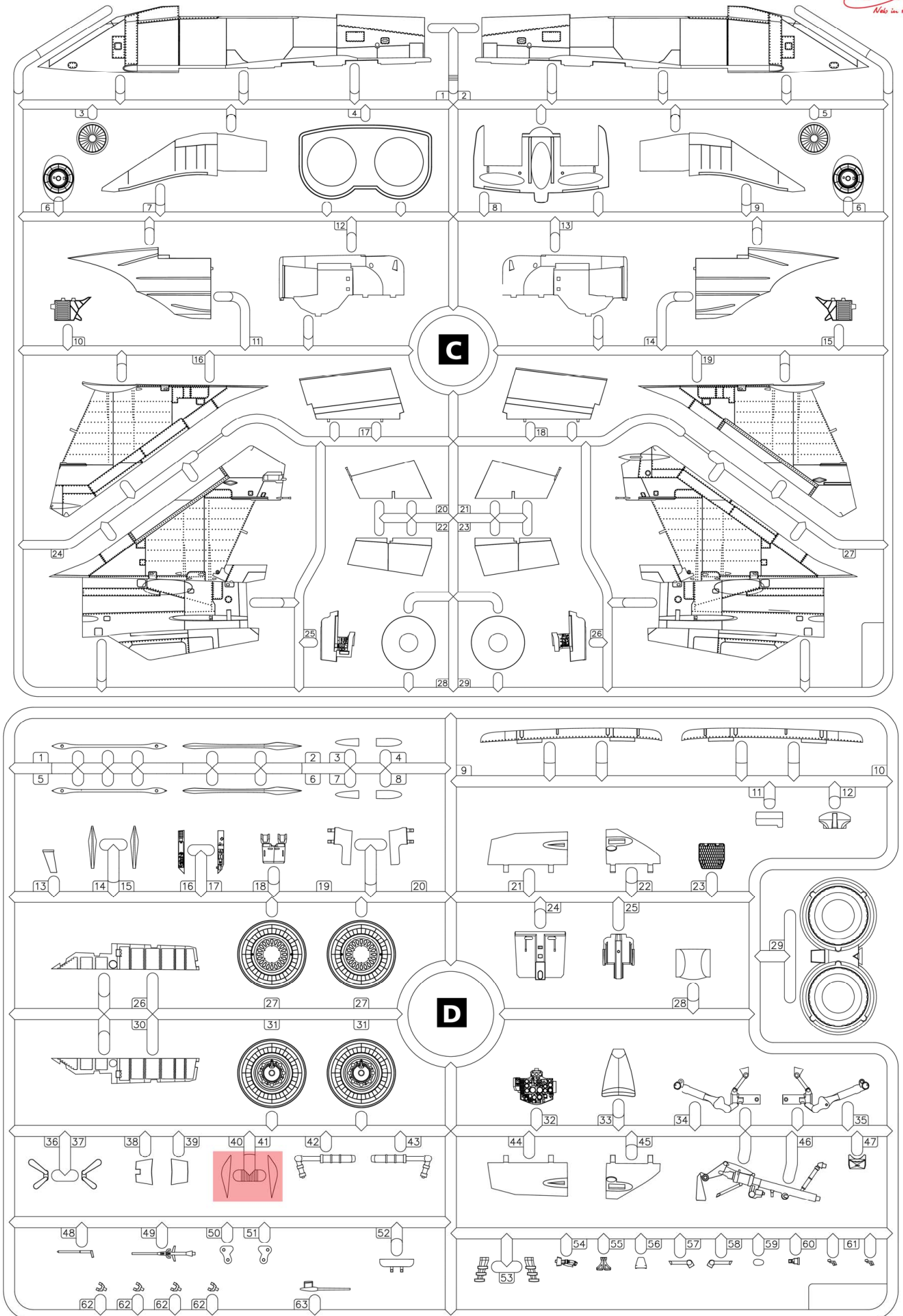

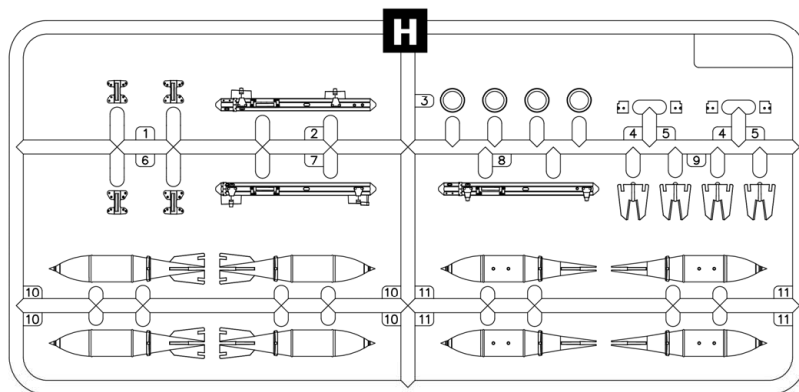
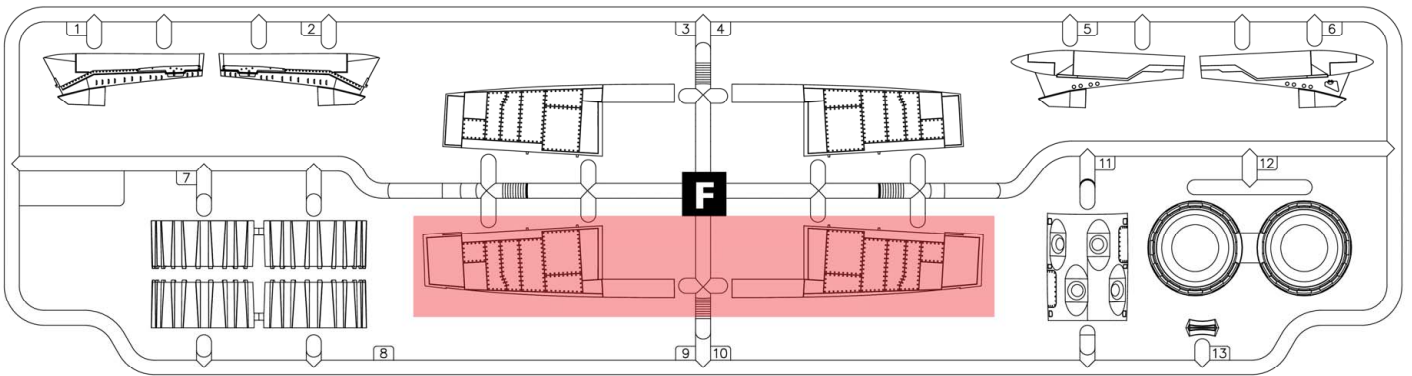
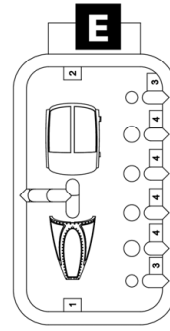
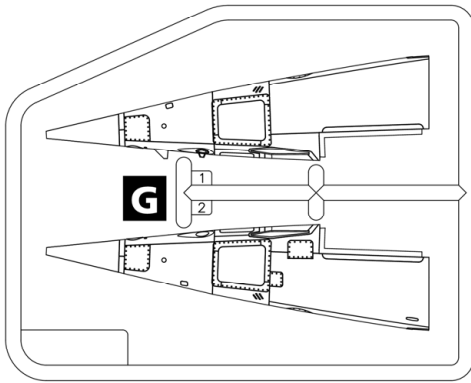

x2

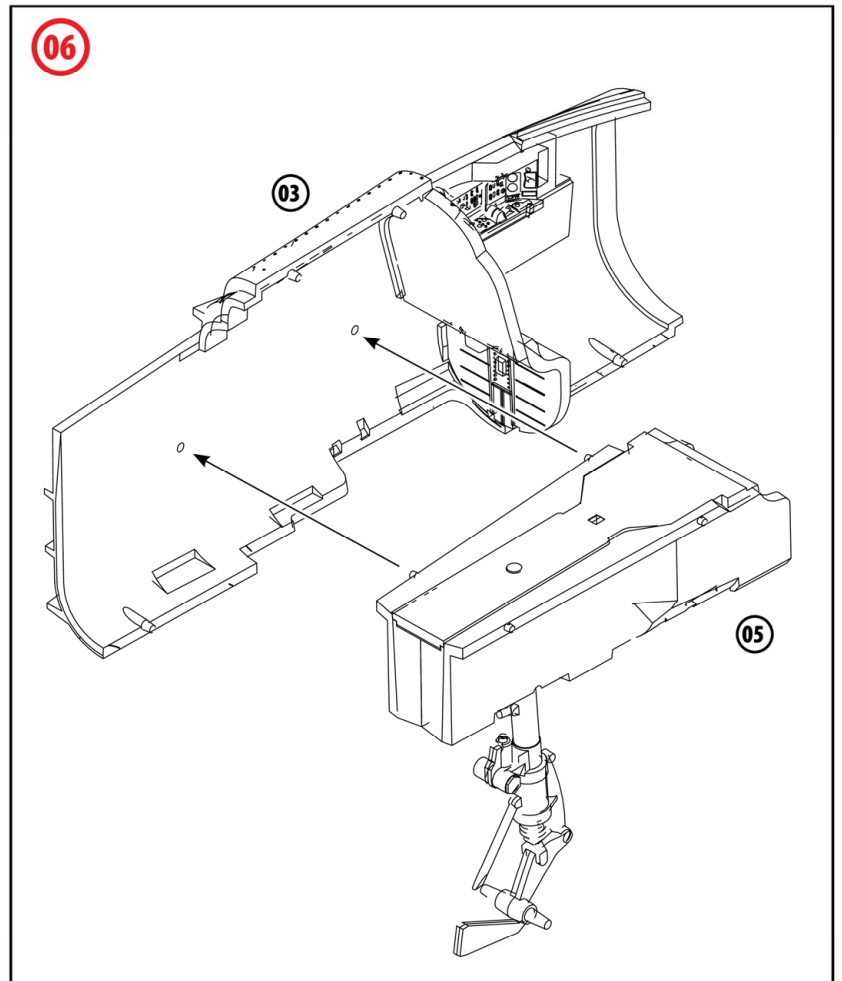
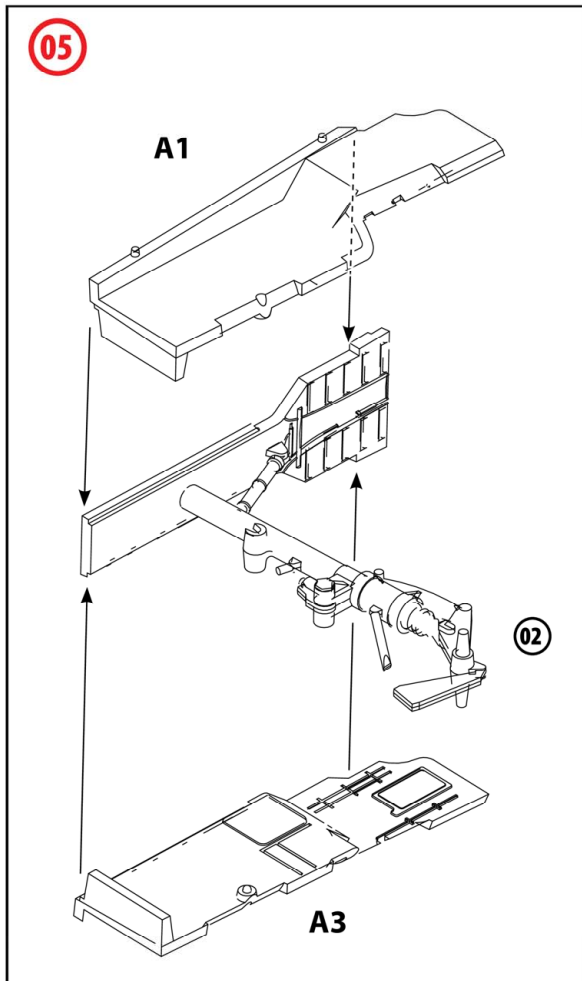
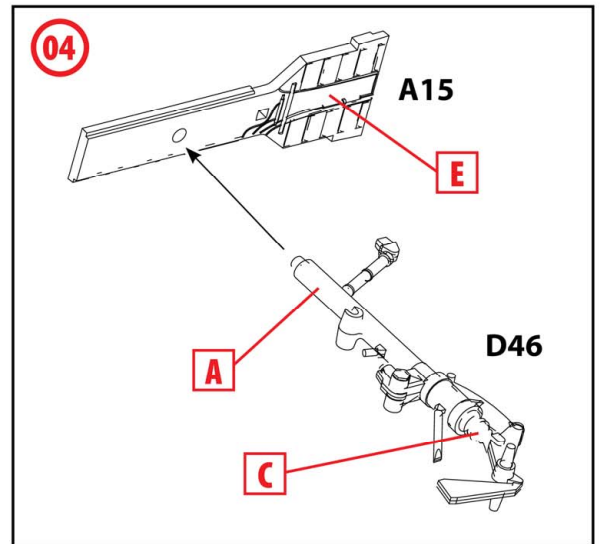
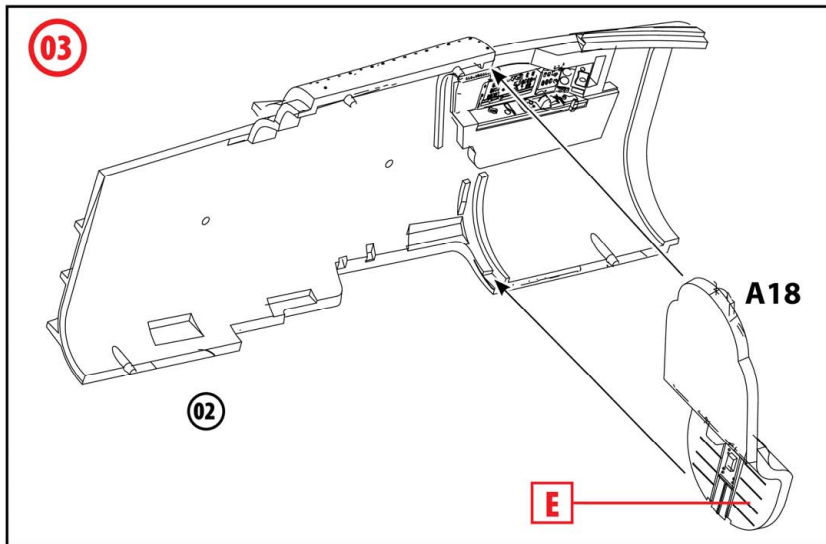
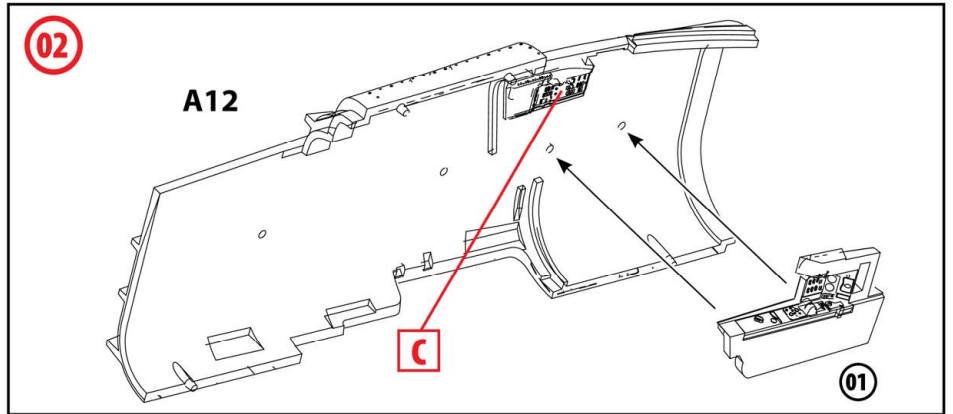
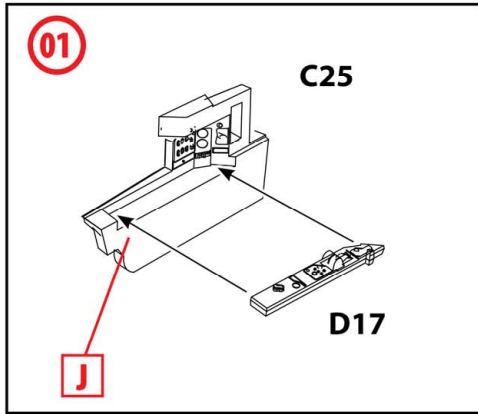

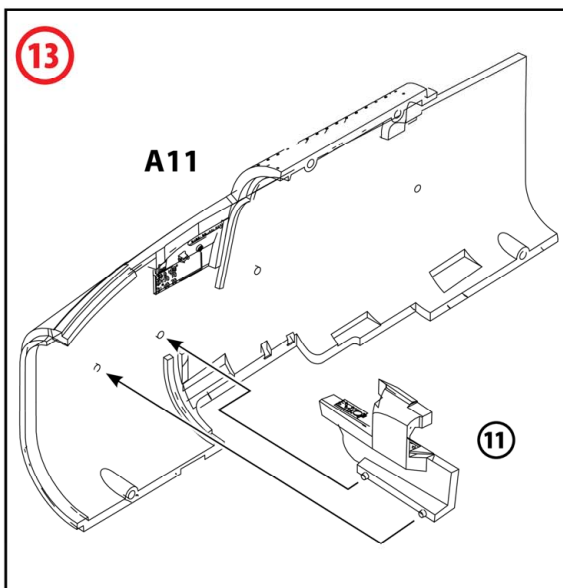
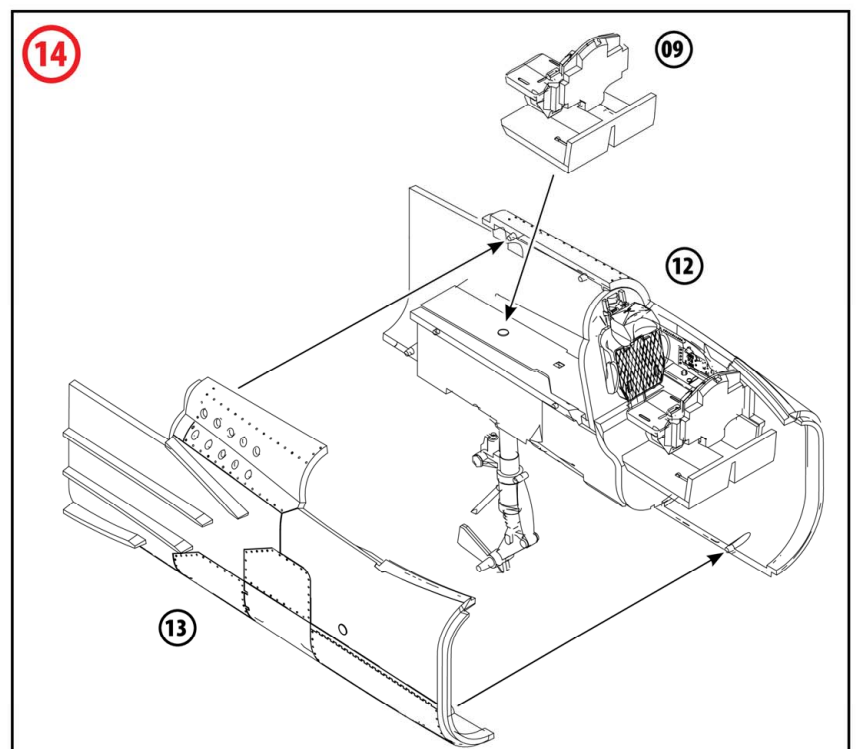
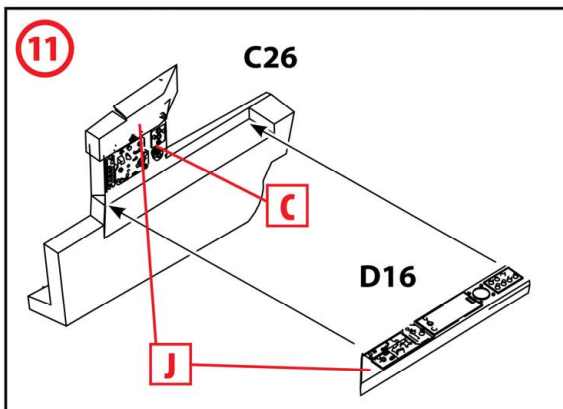
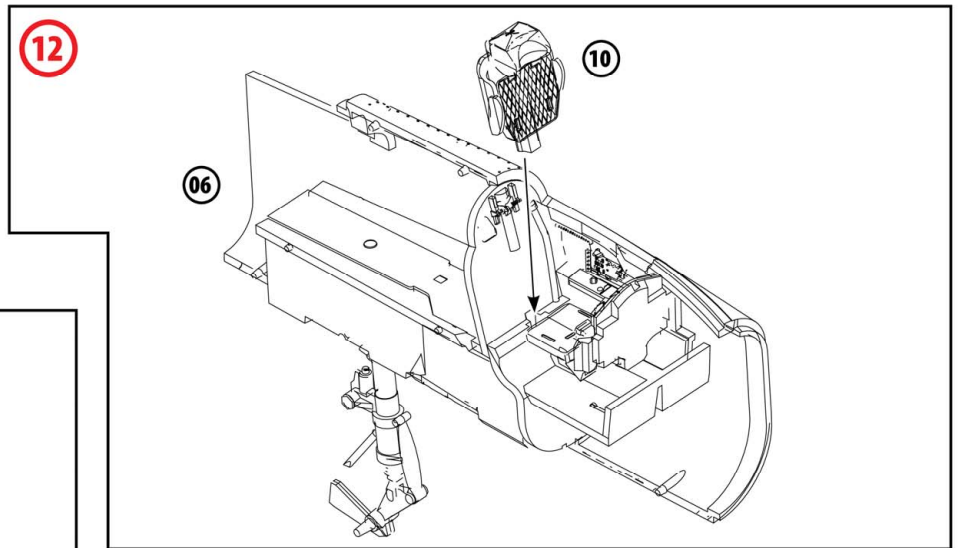
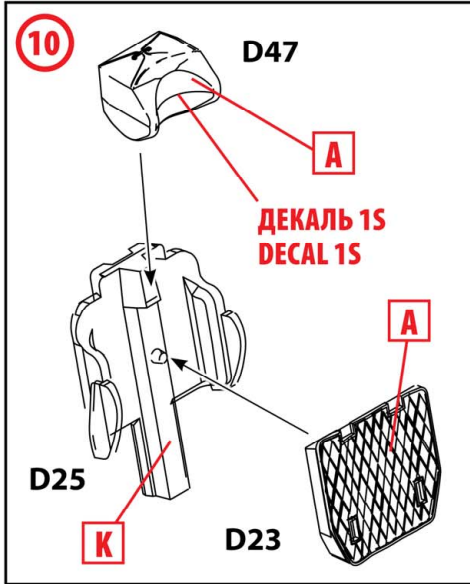
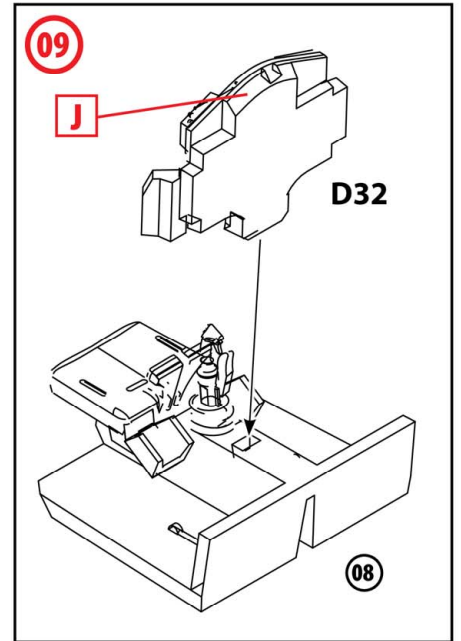
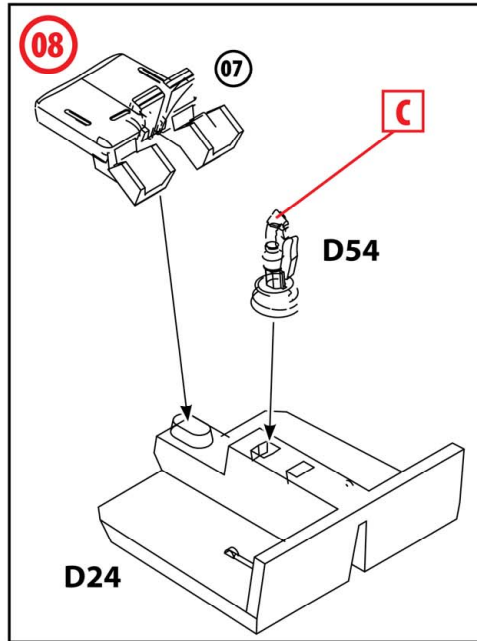
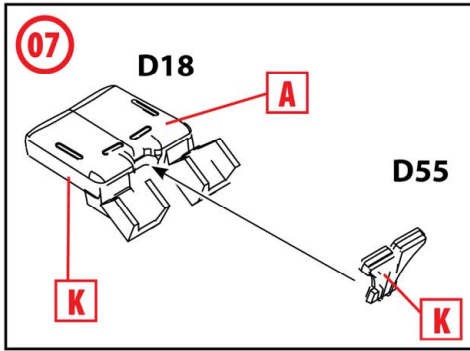

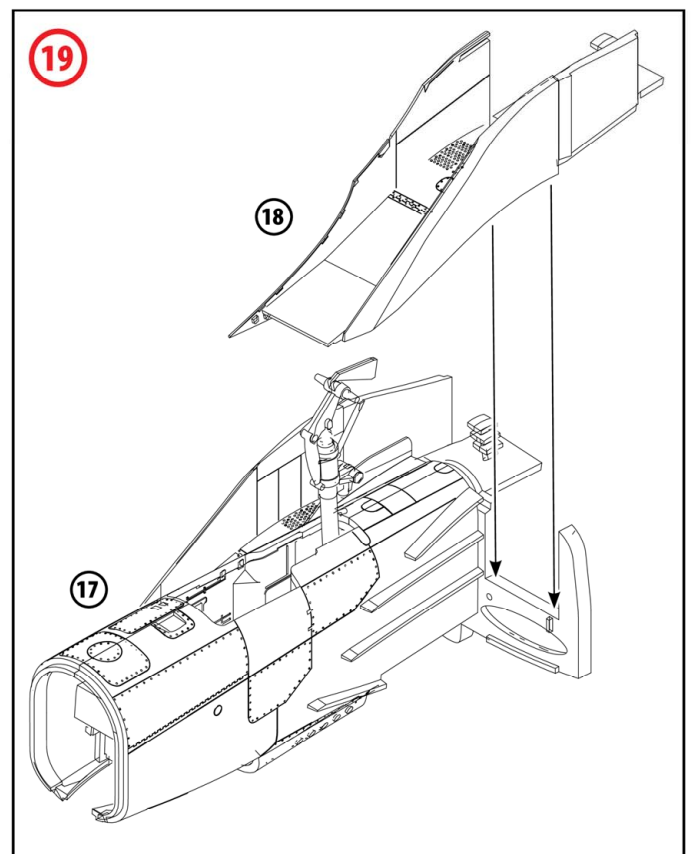
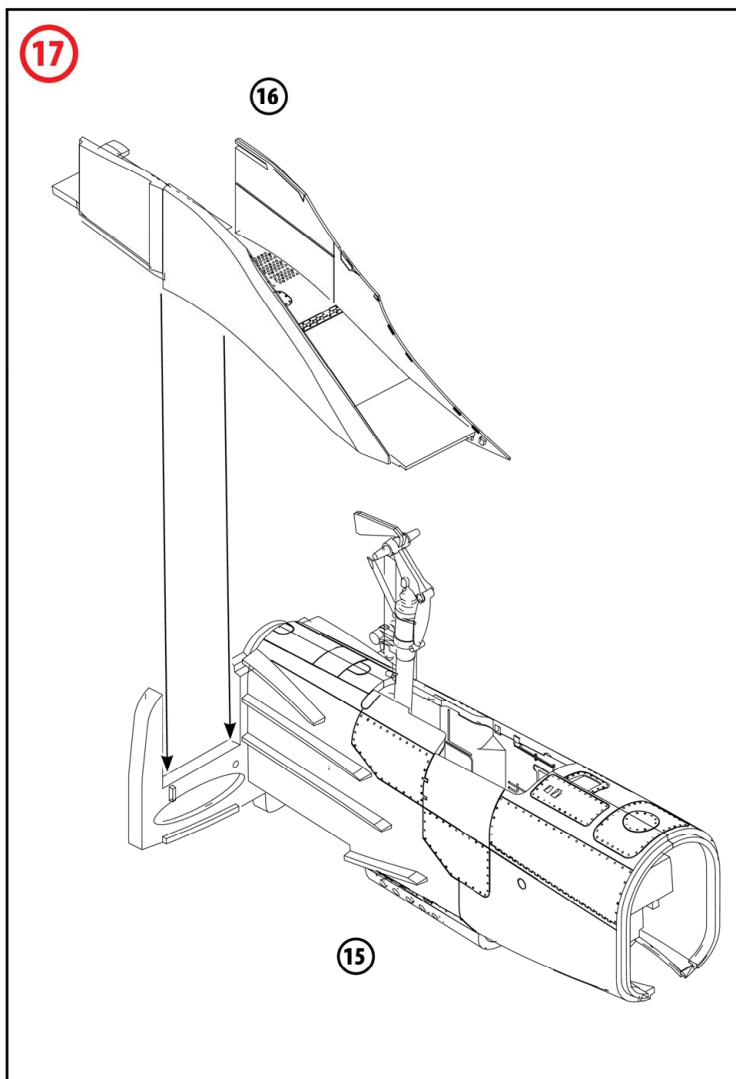
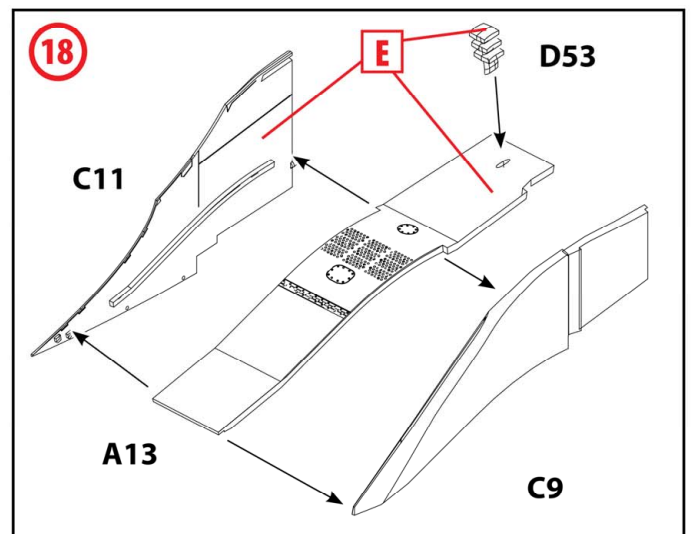
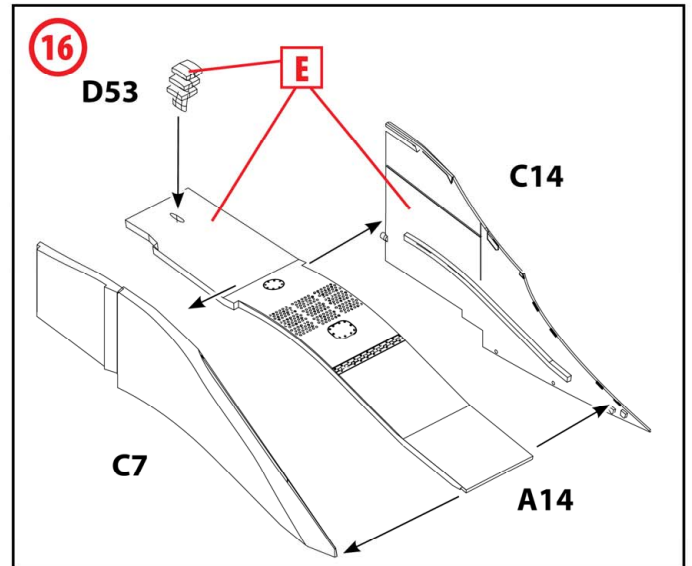
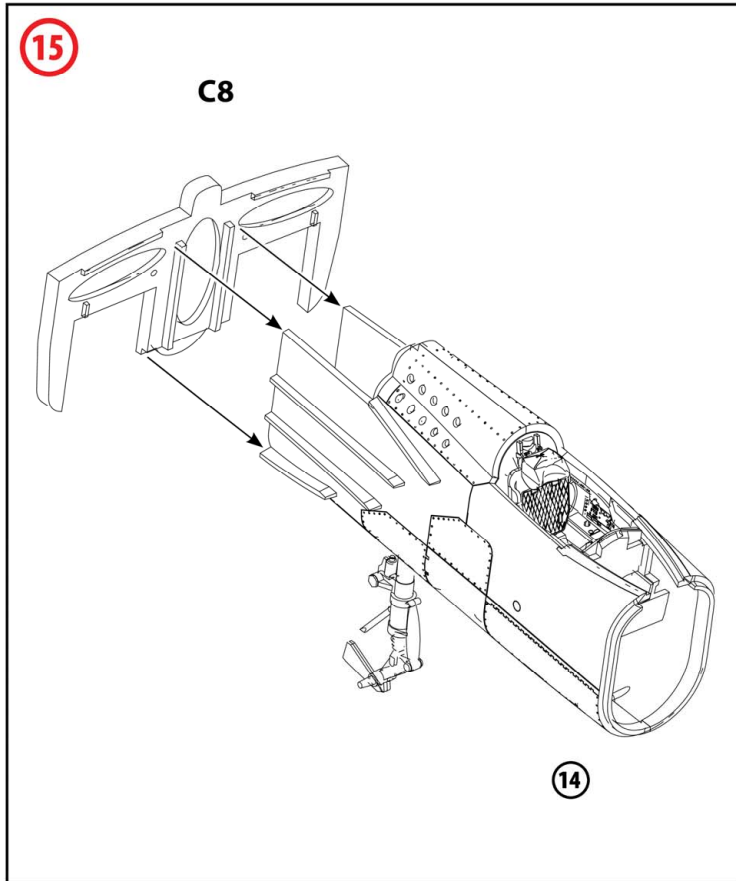

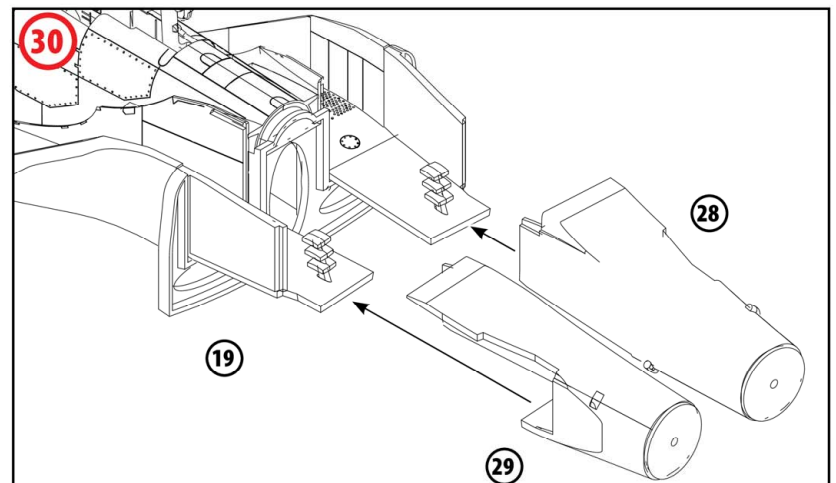
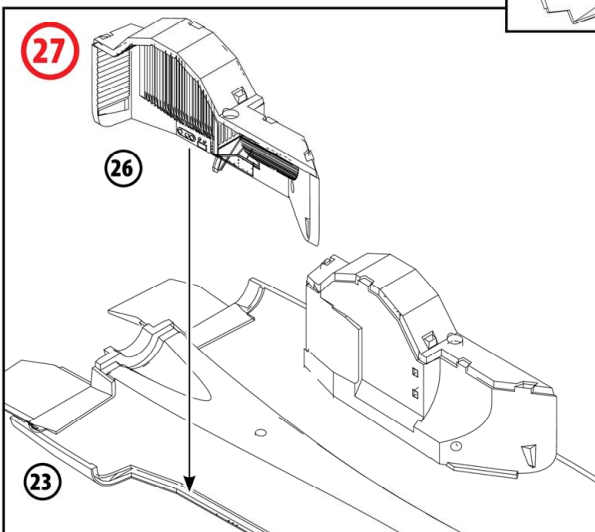
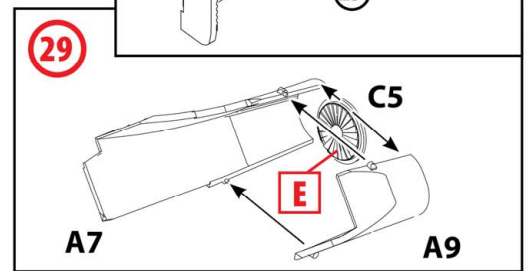
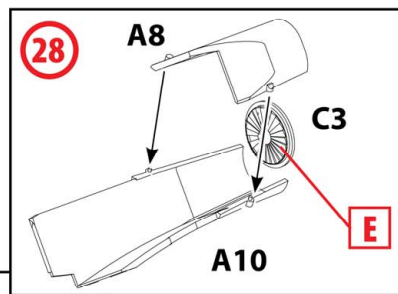
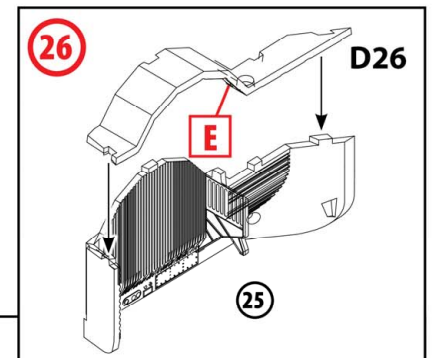
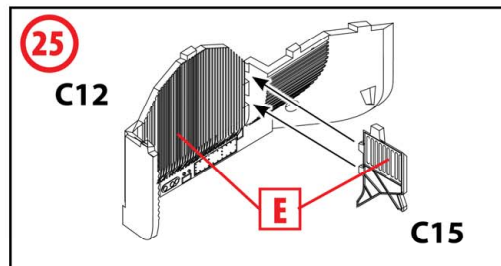
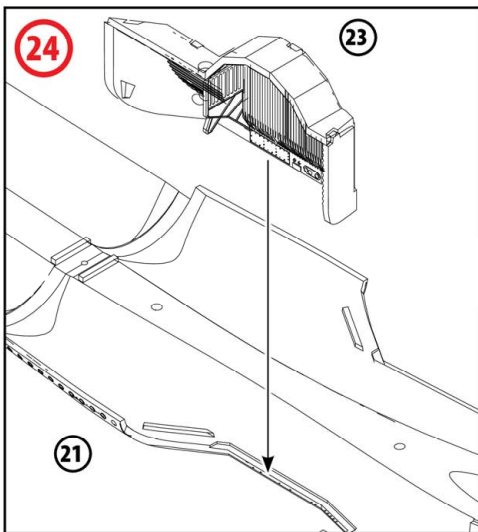
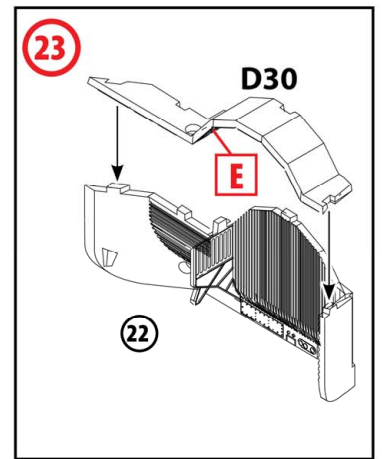
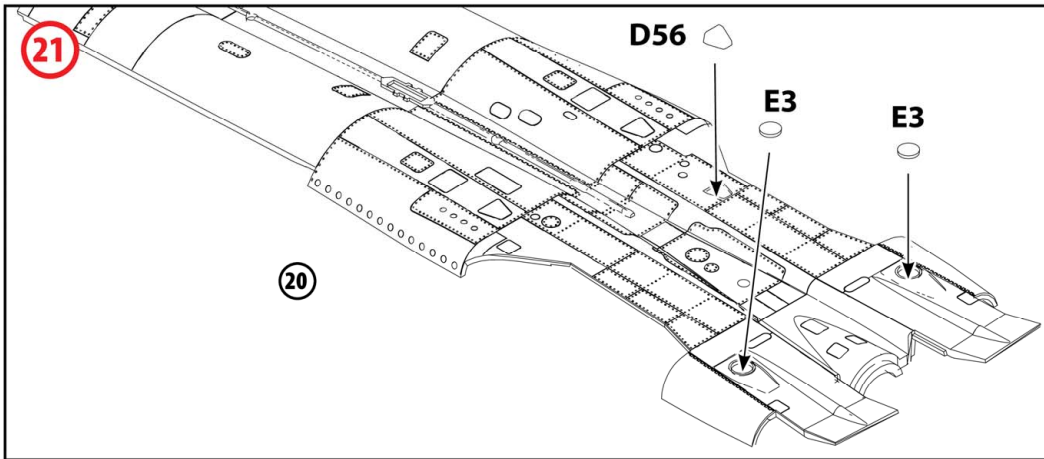
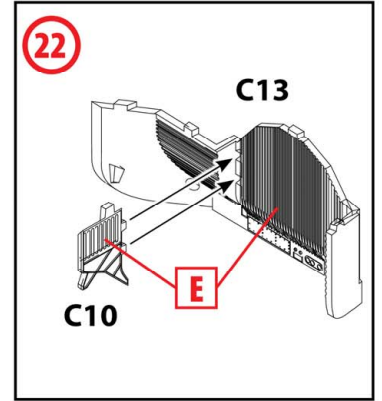
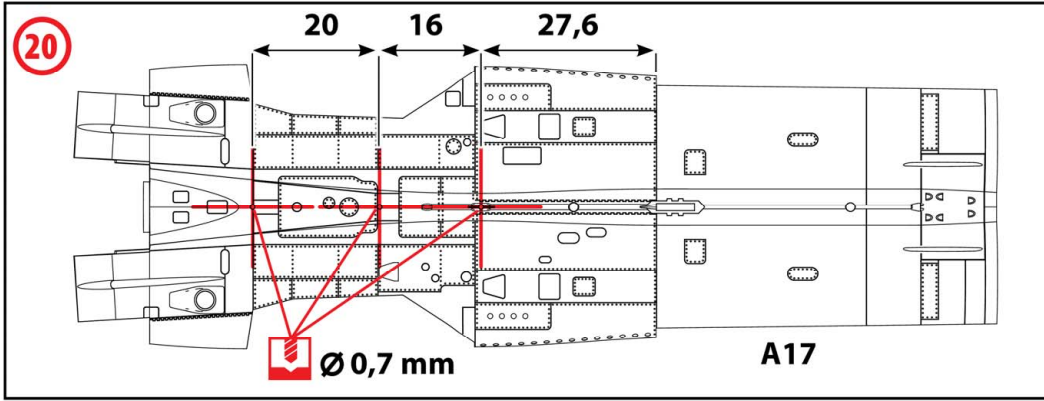

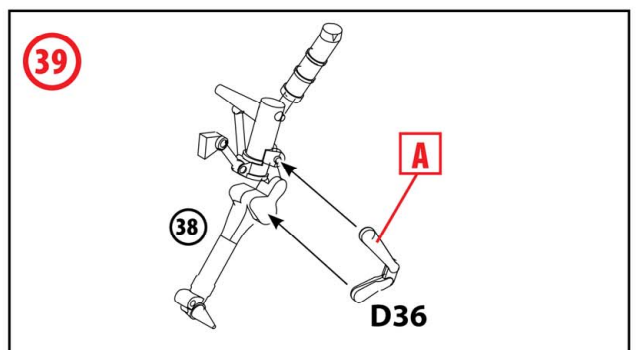
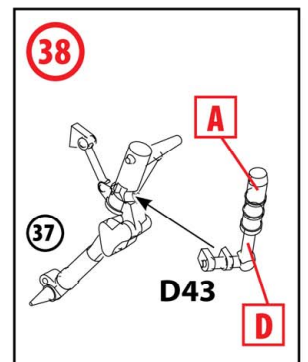
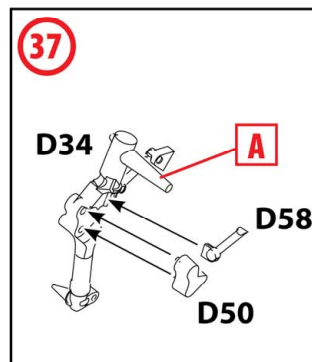
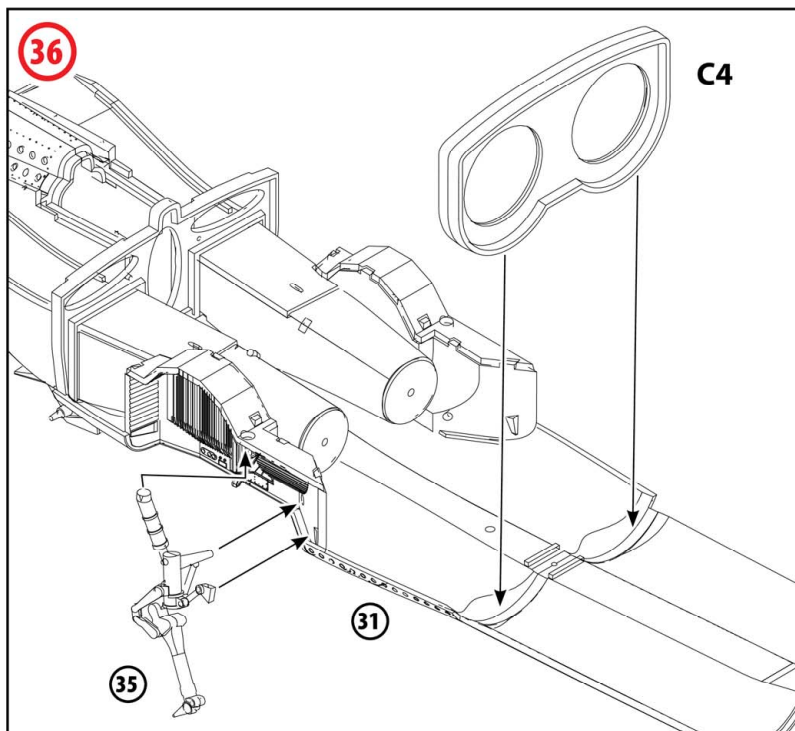
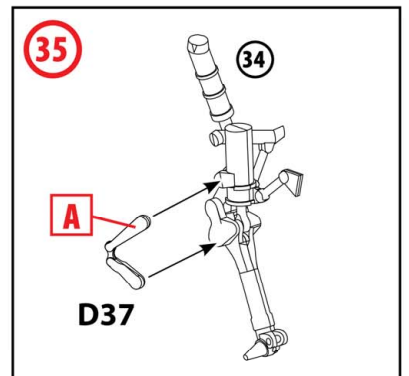
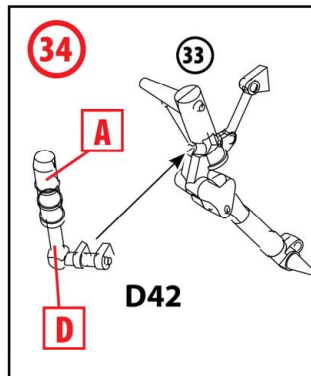
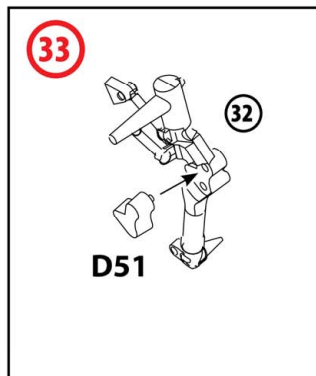
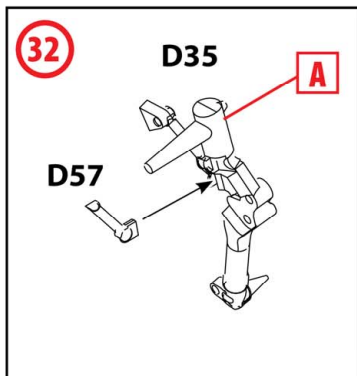
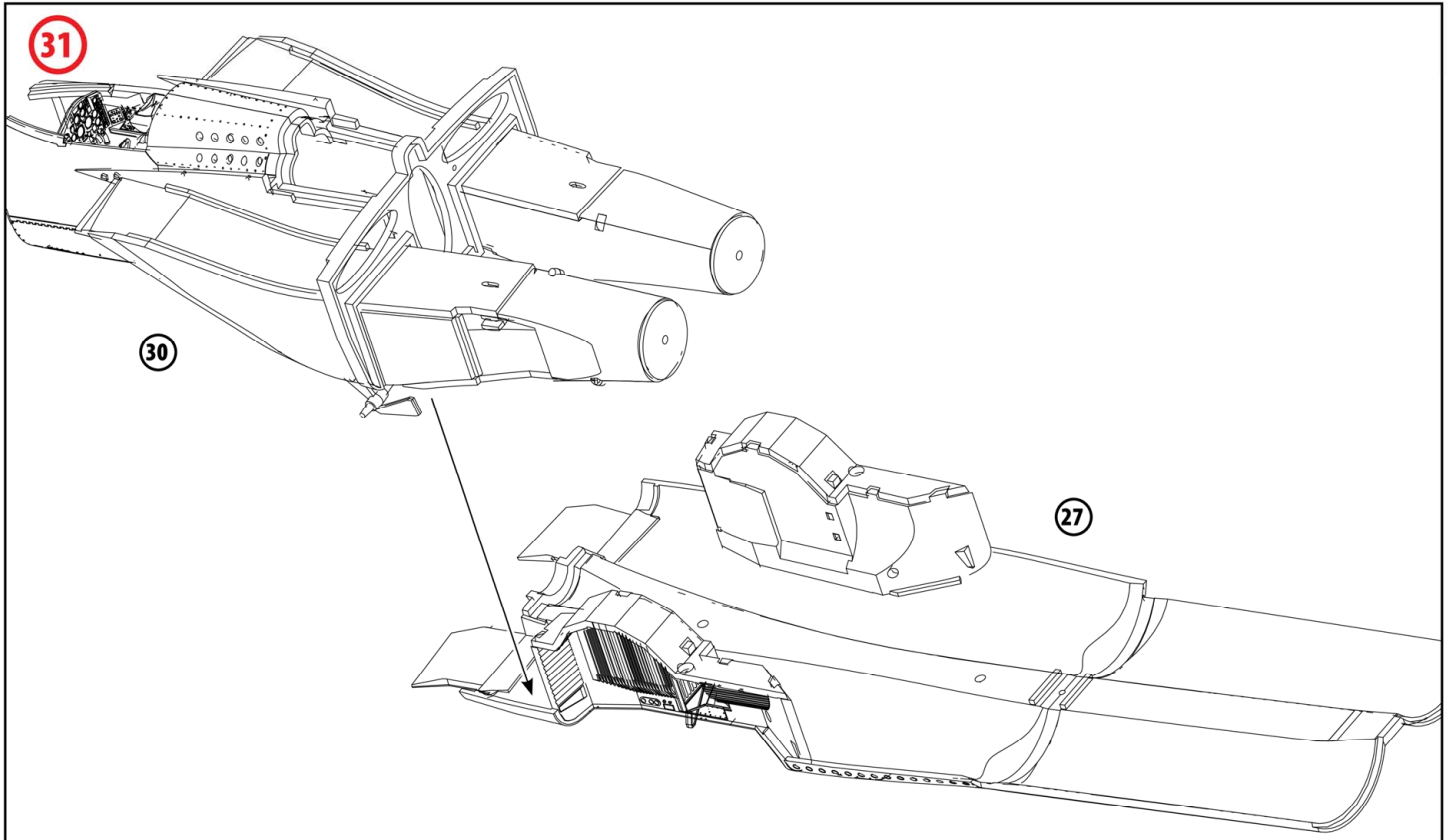

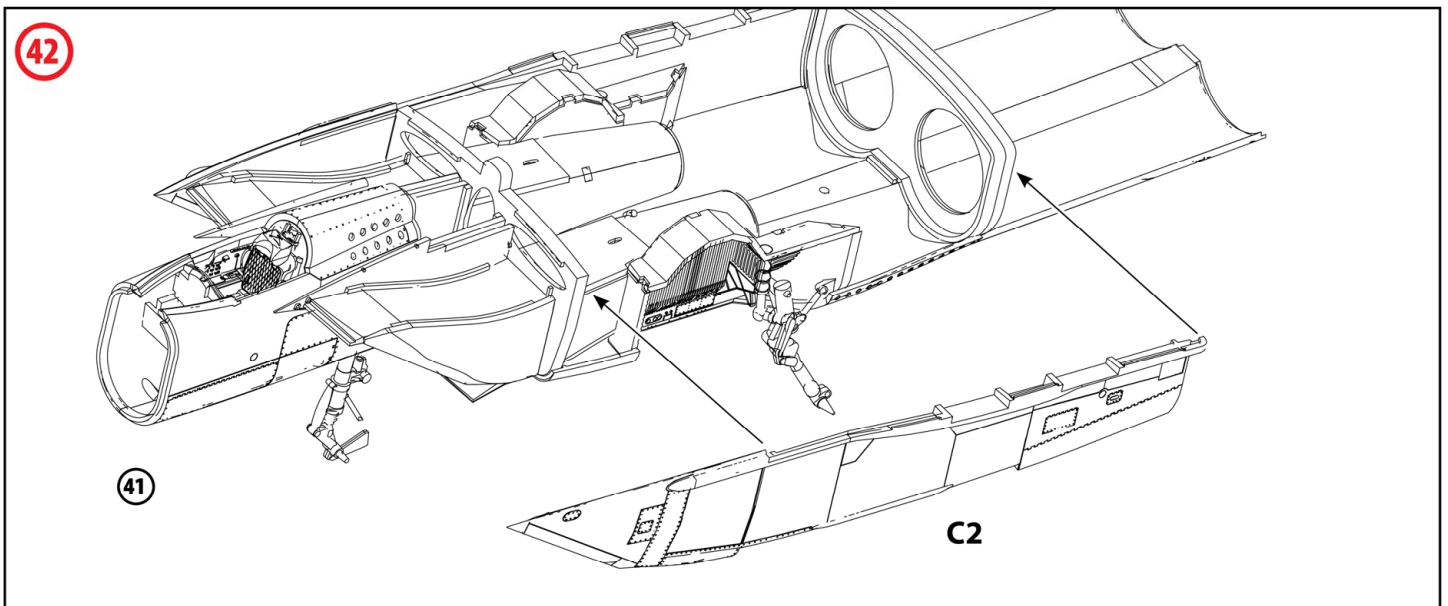
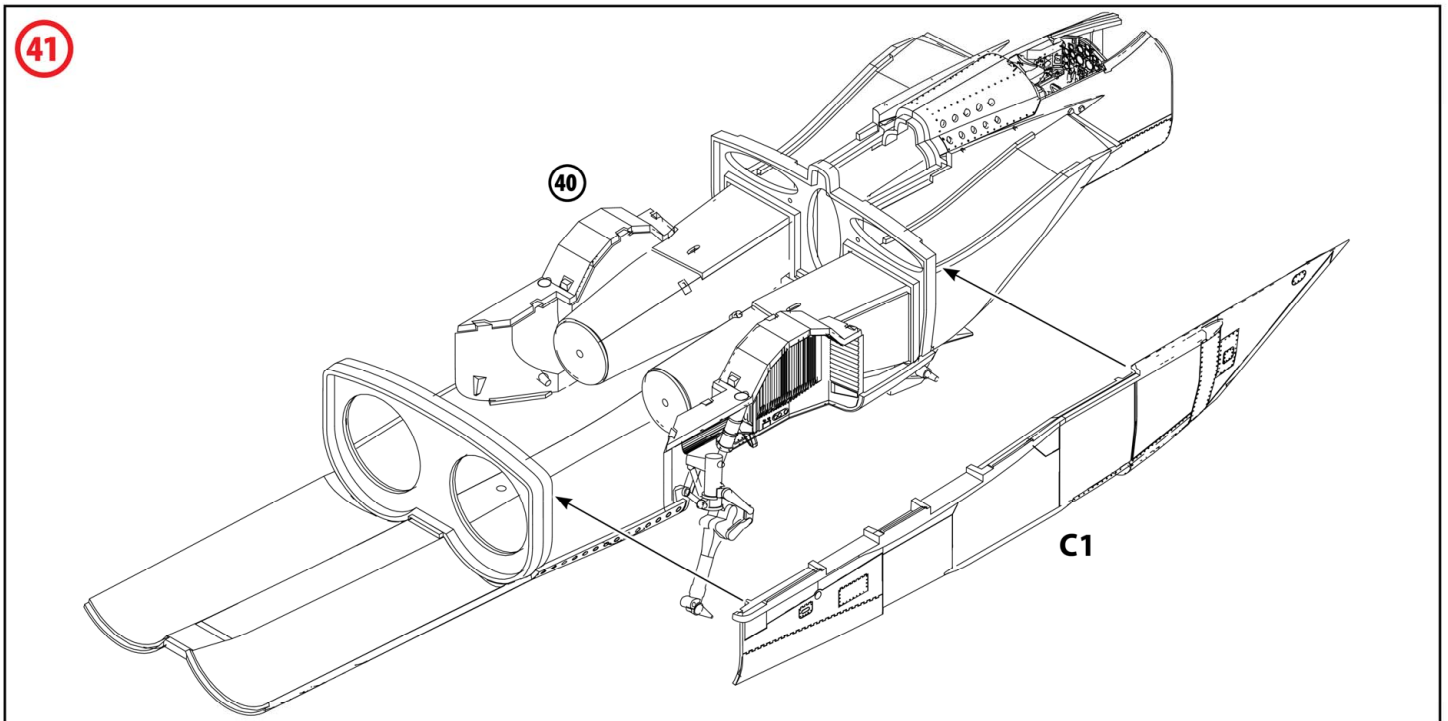
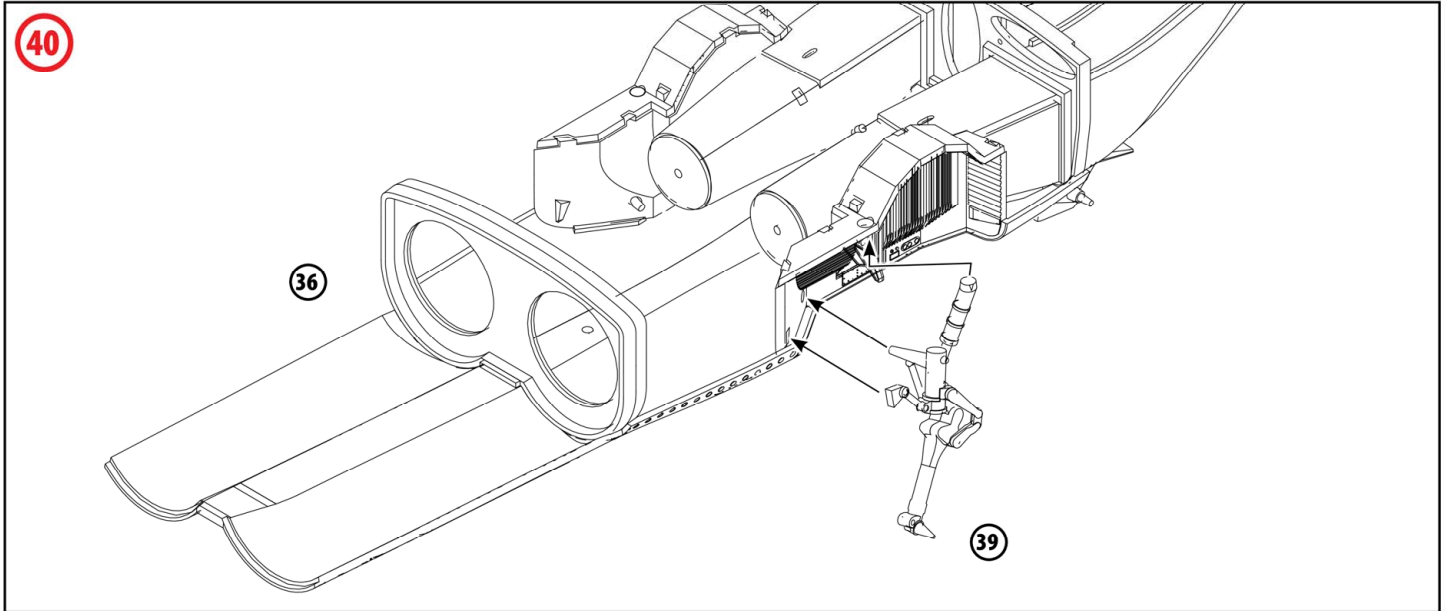

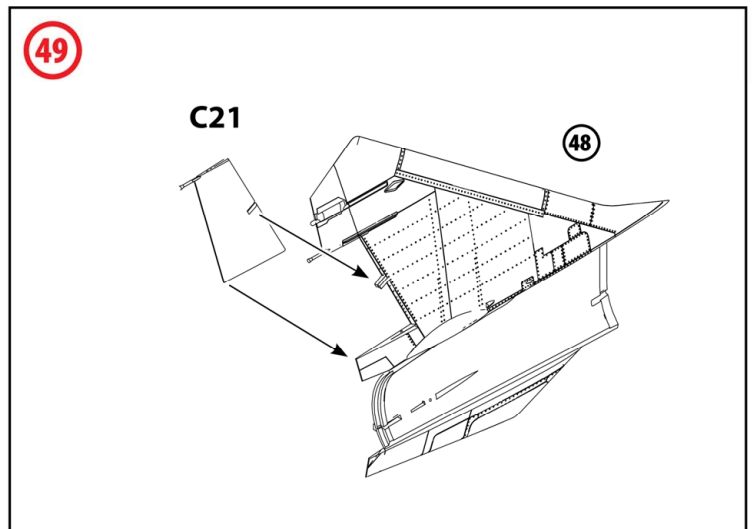
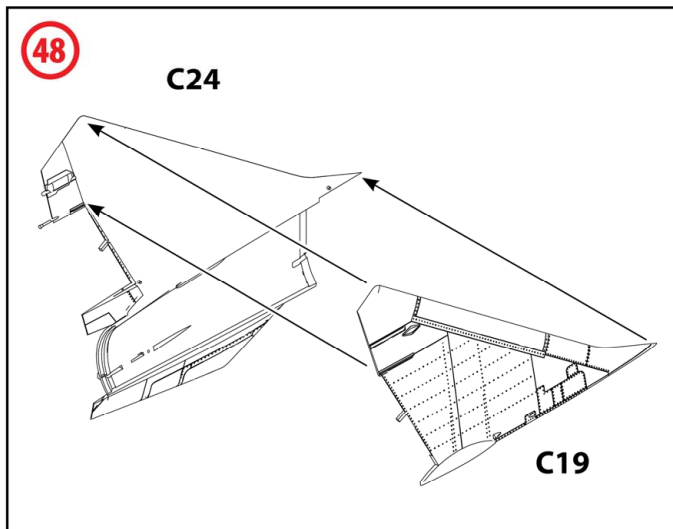
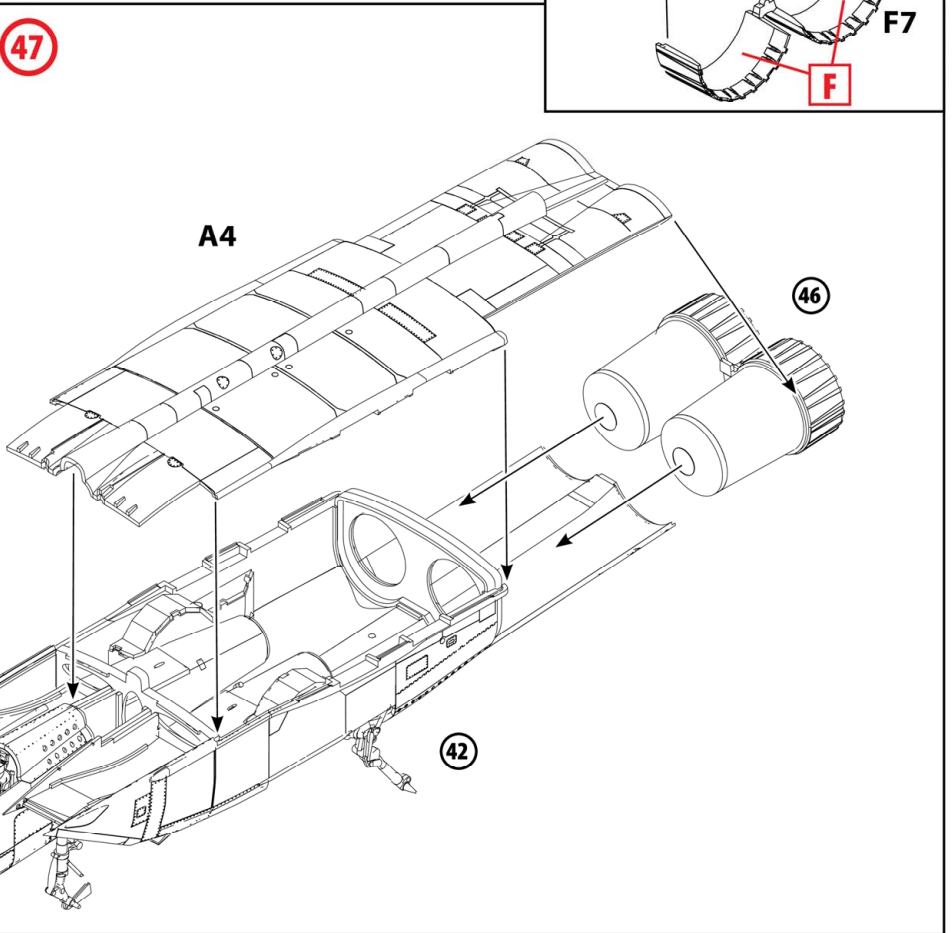
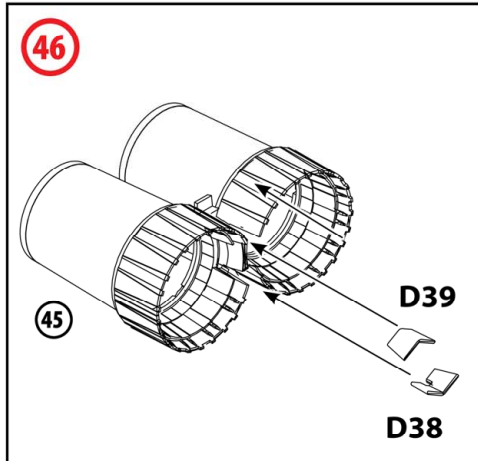
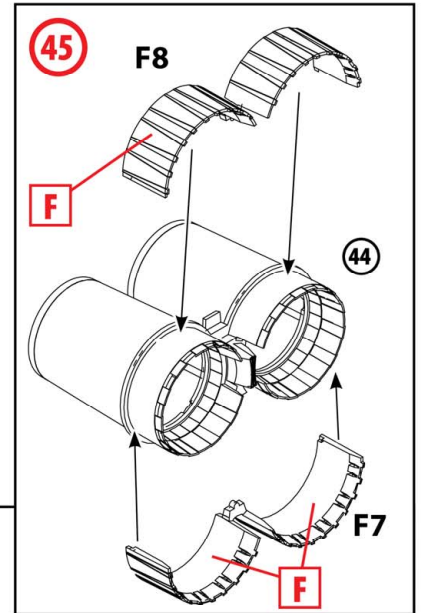
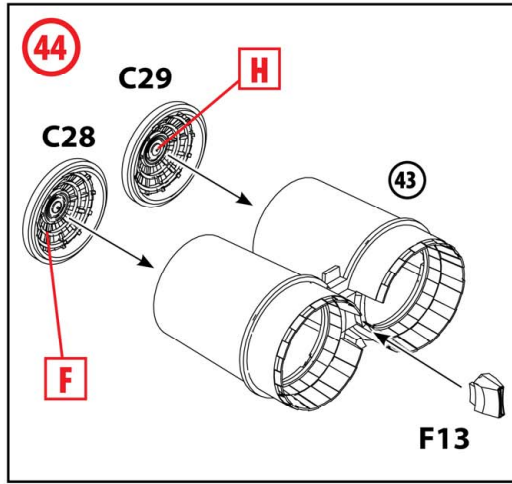
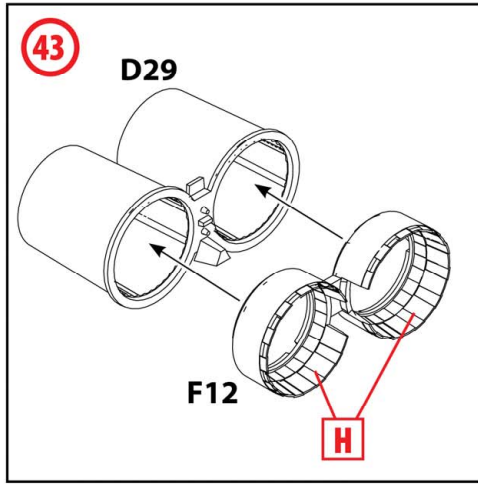

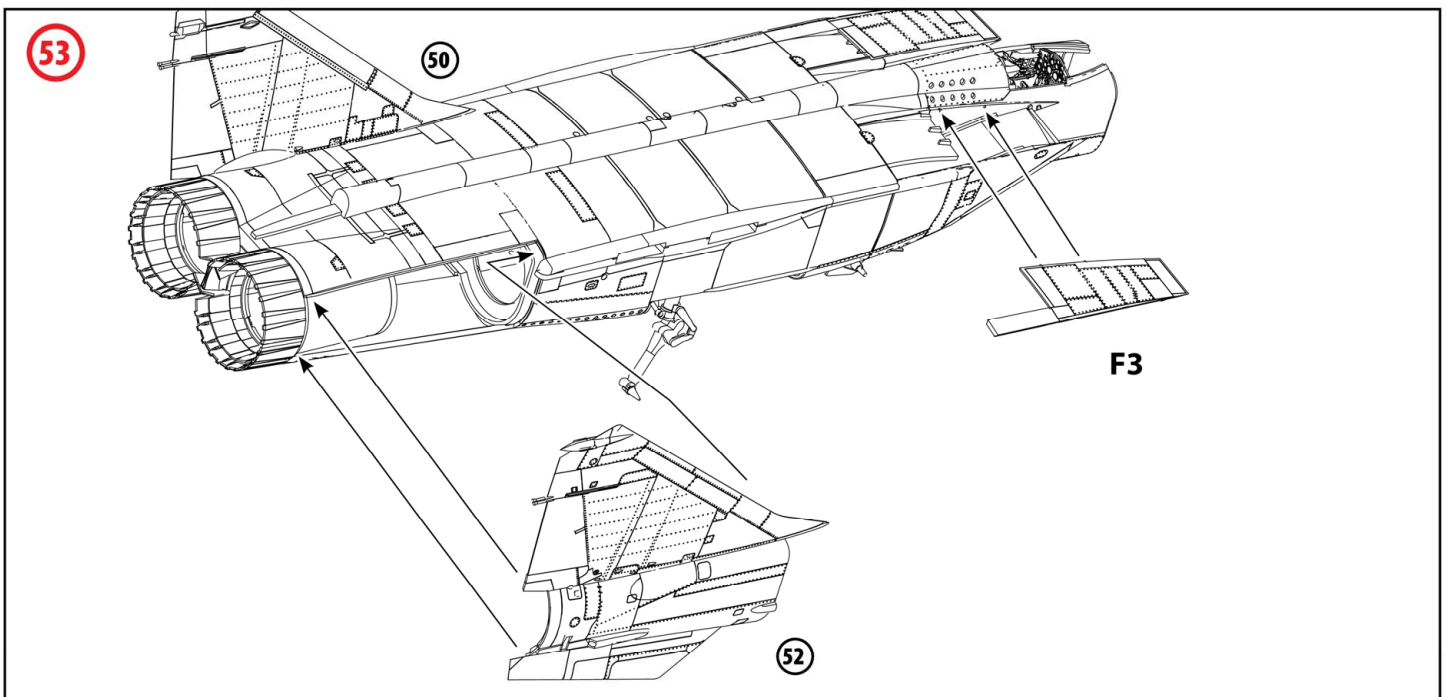
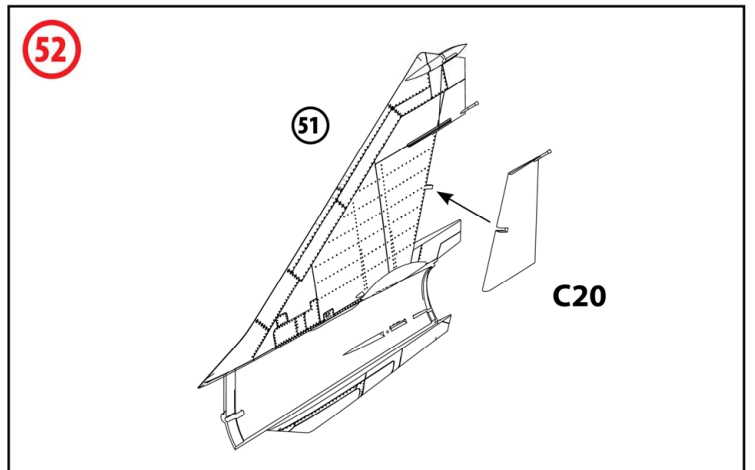
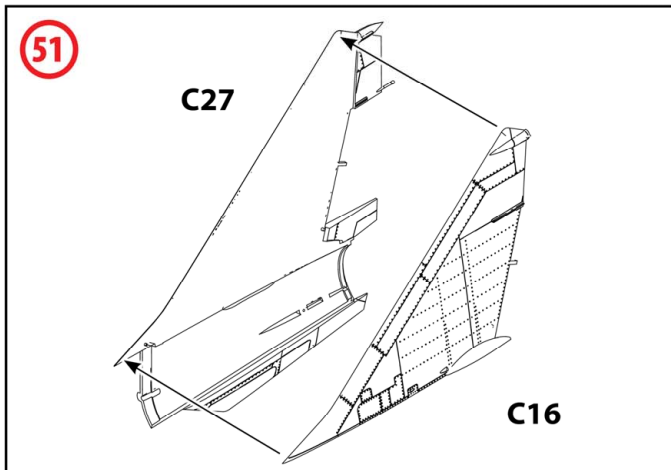
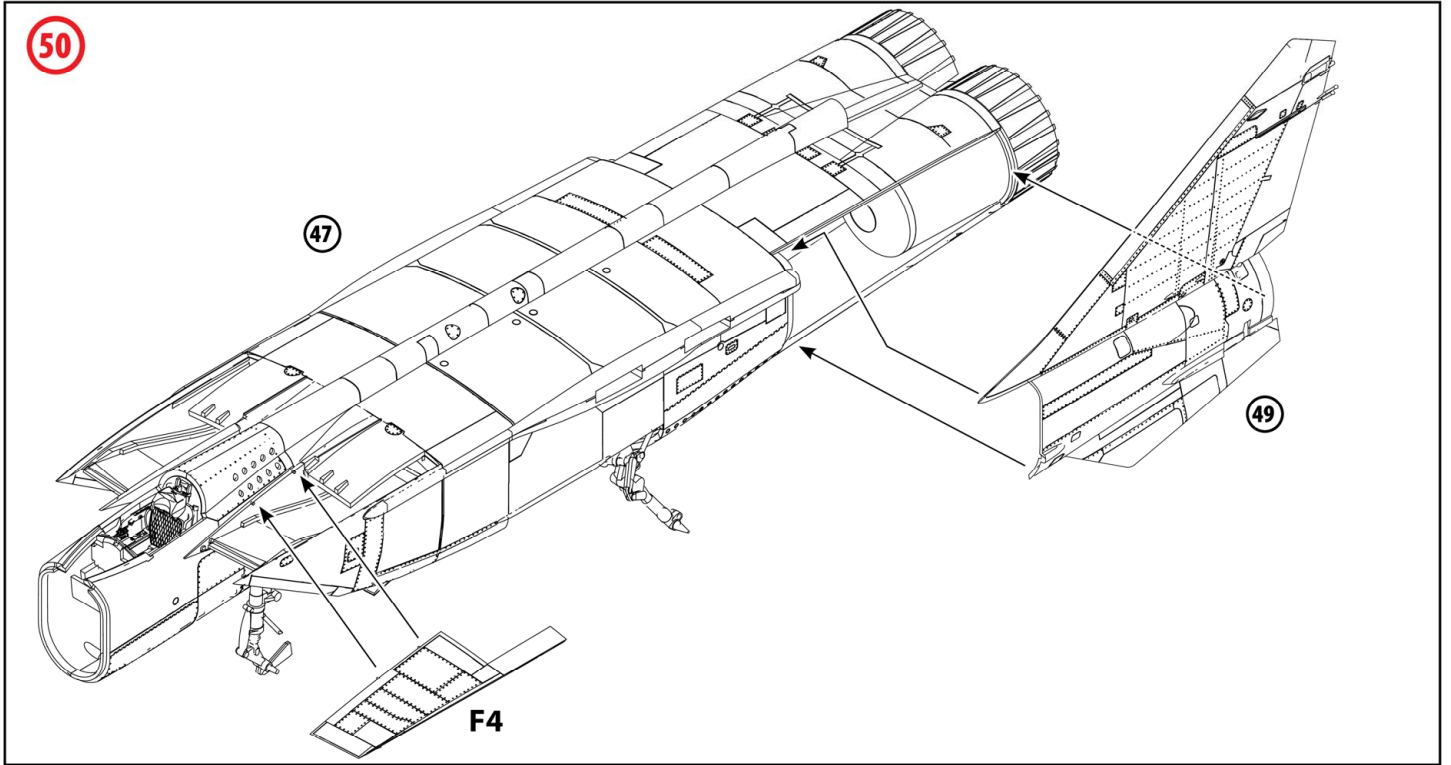

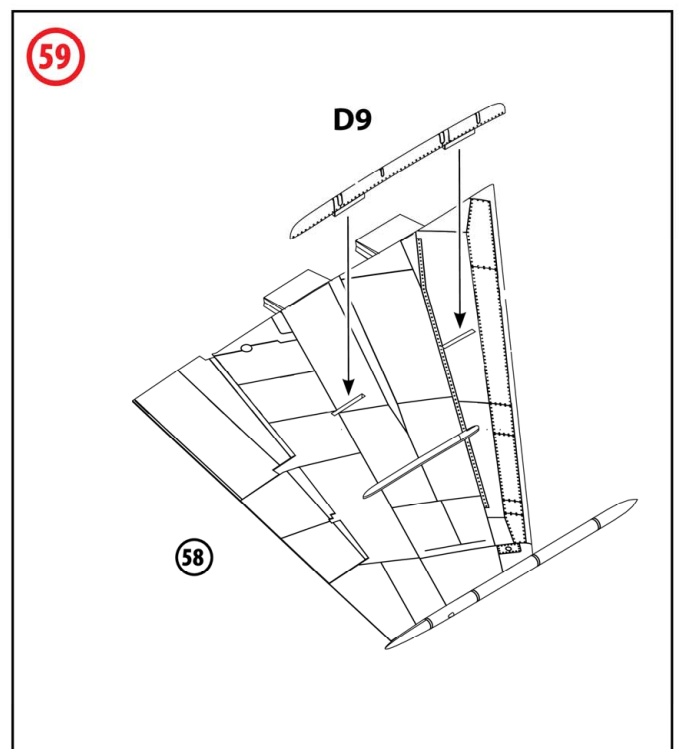
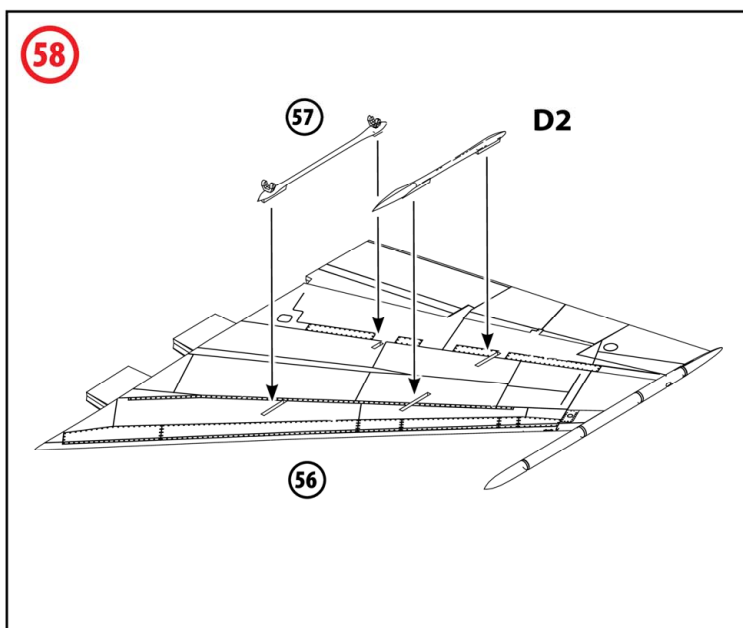
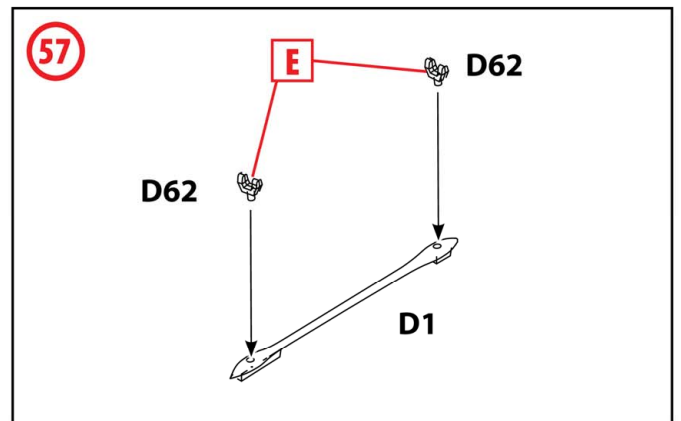
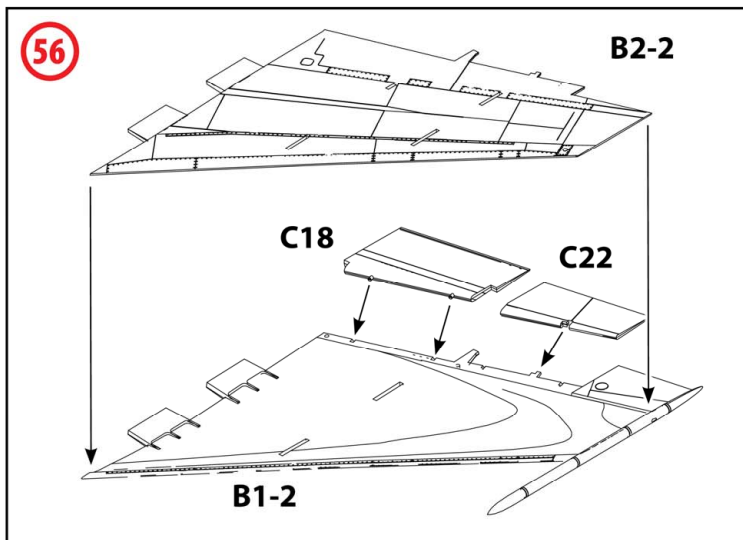
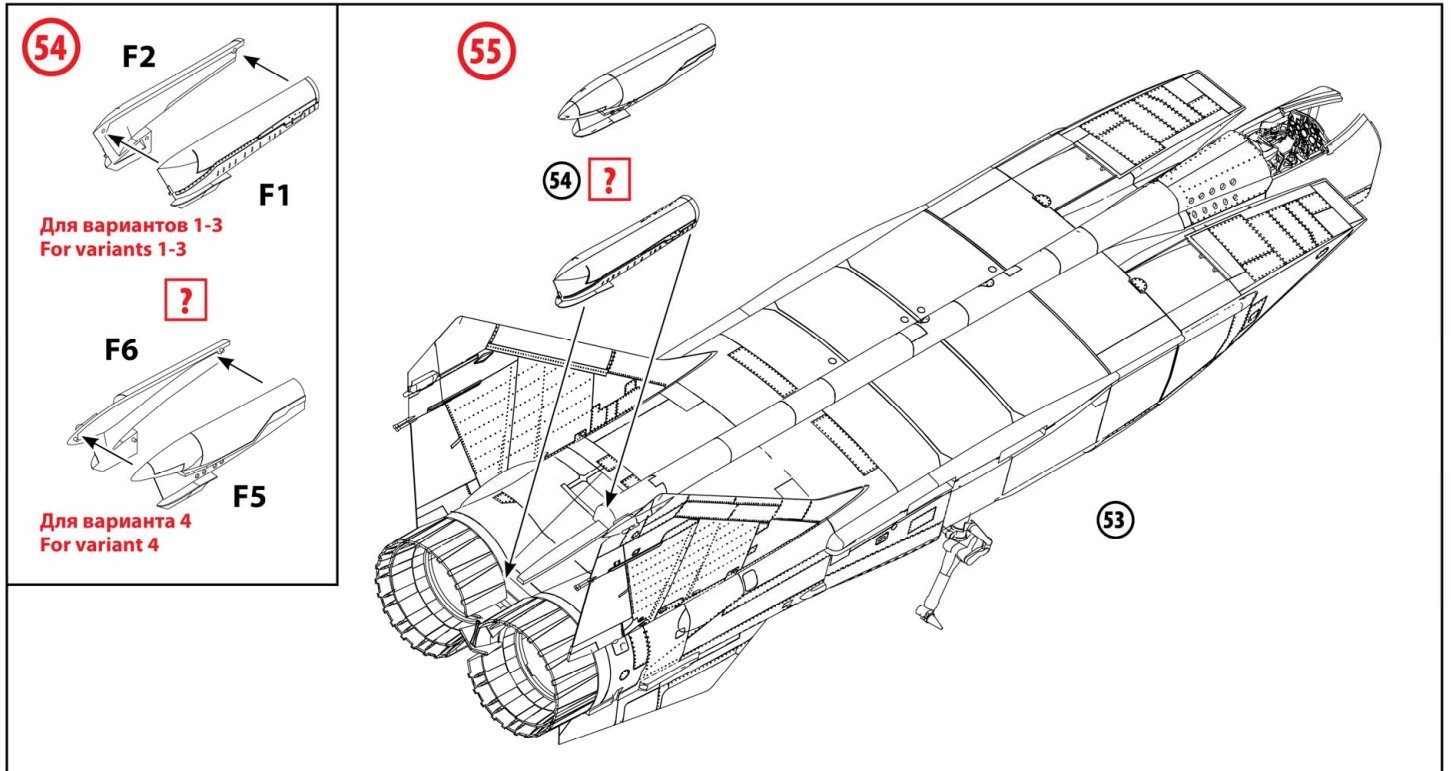

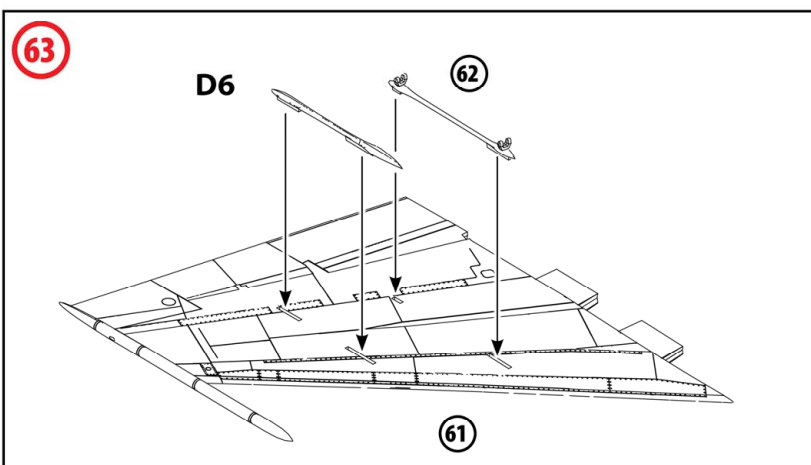
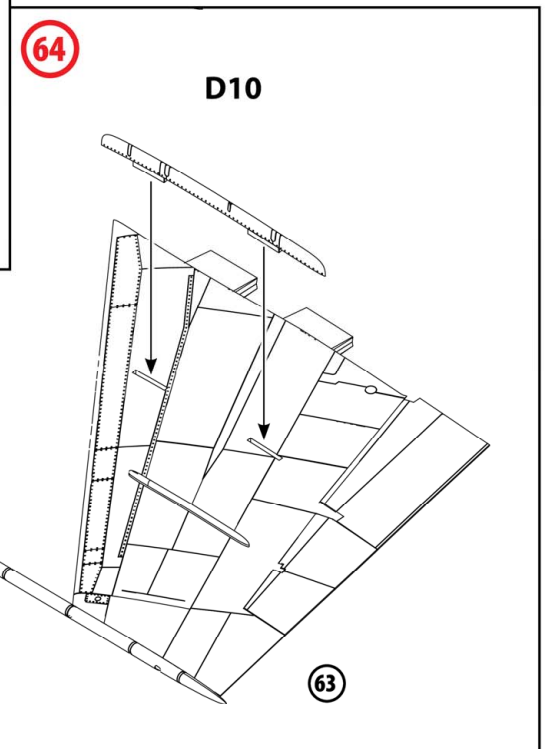
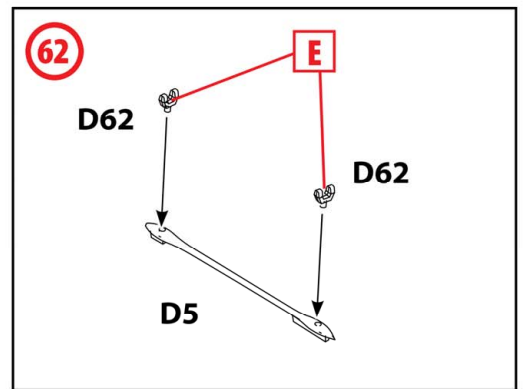
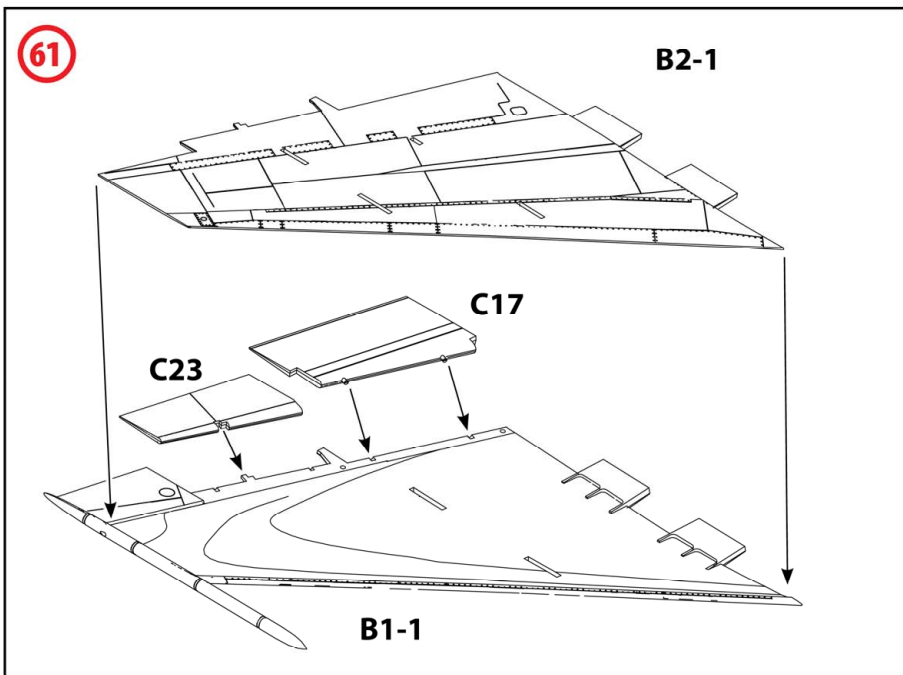
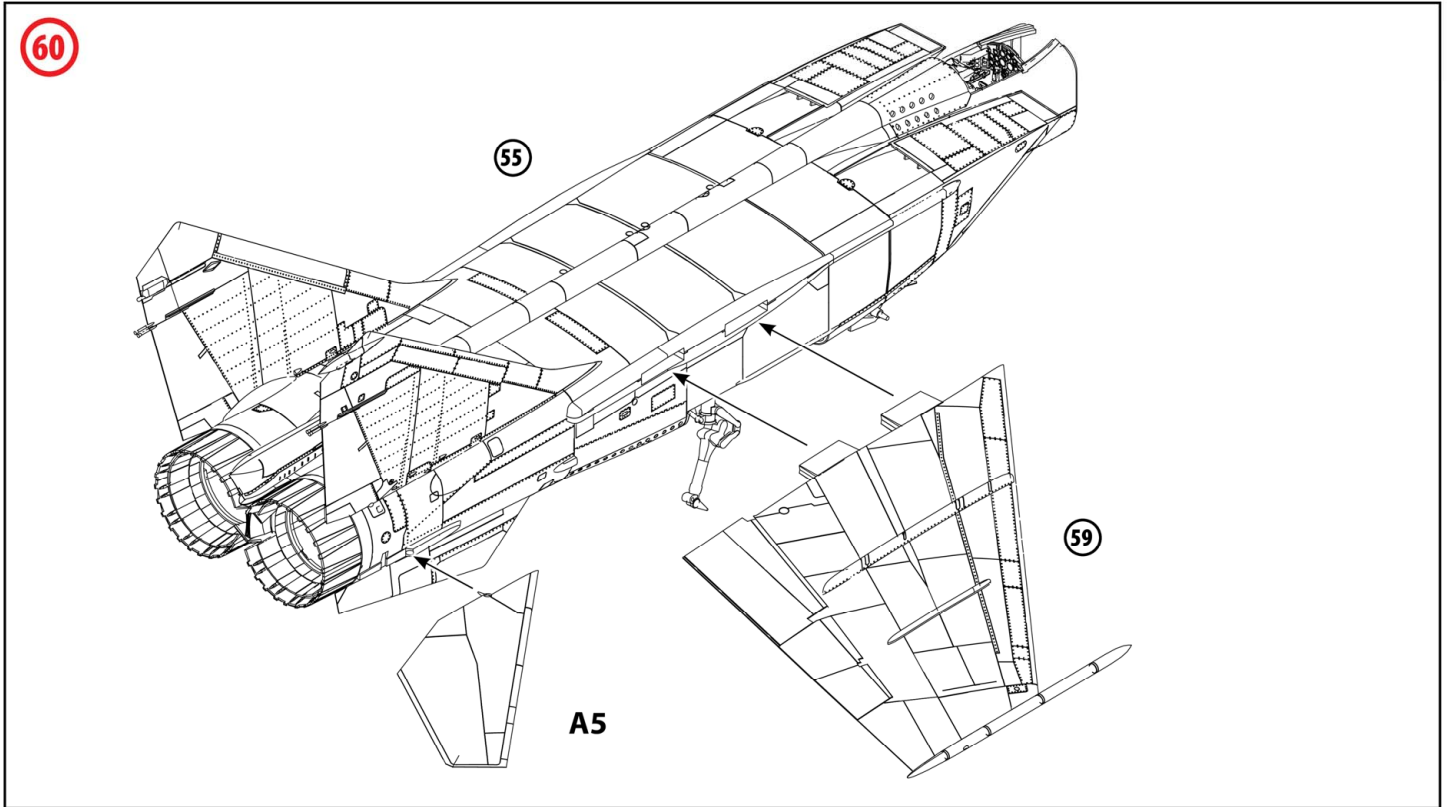

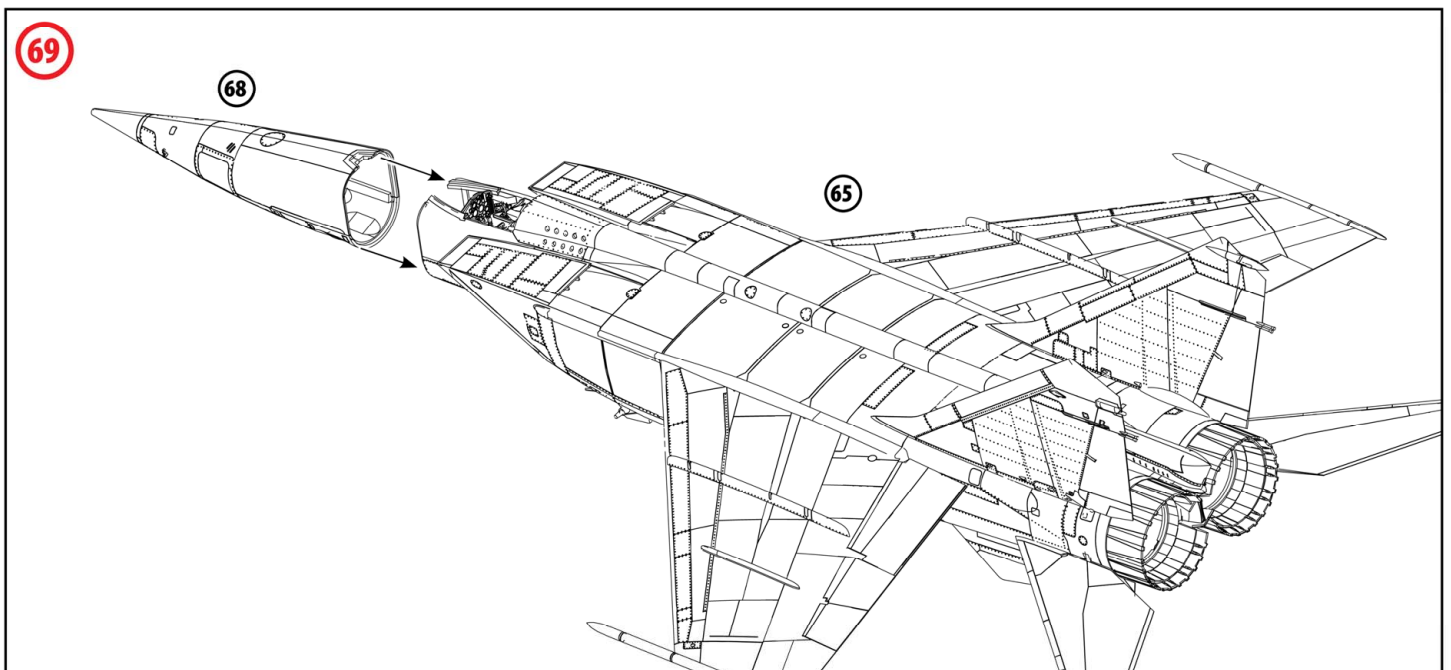
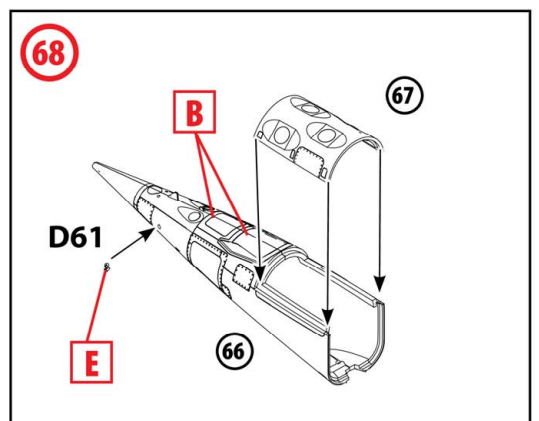
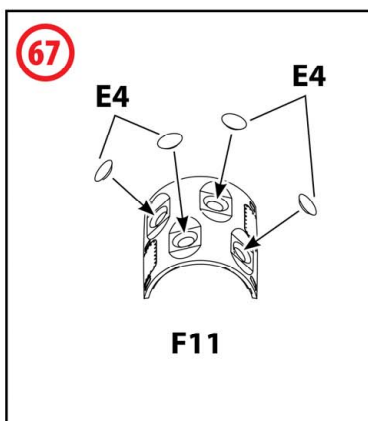
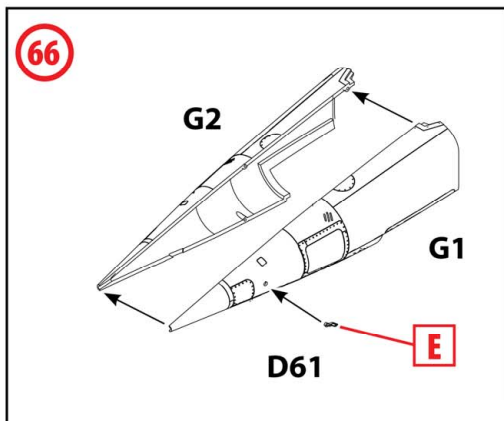
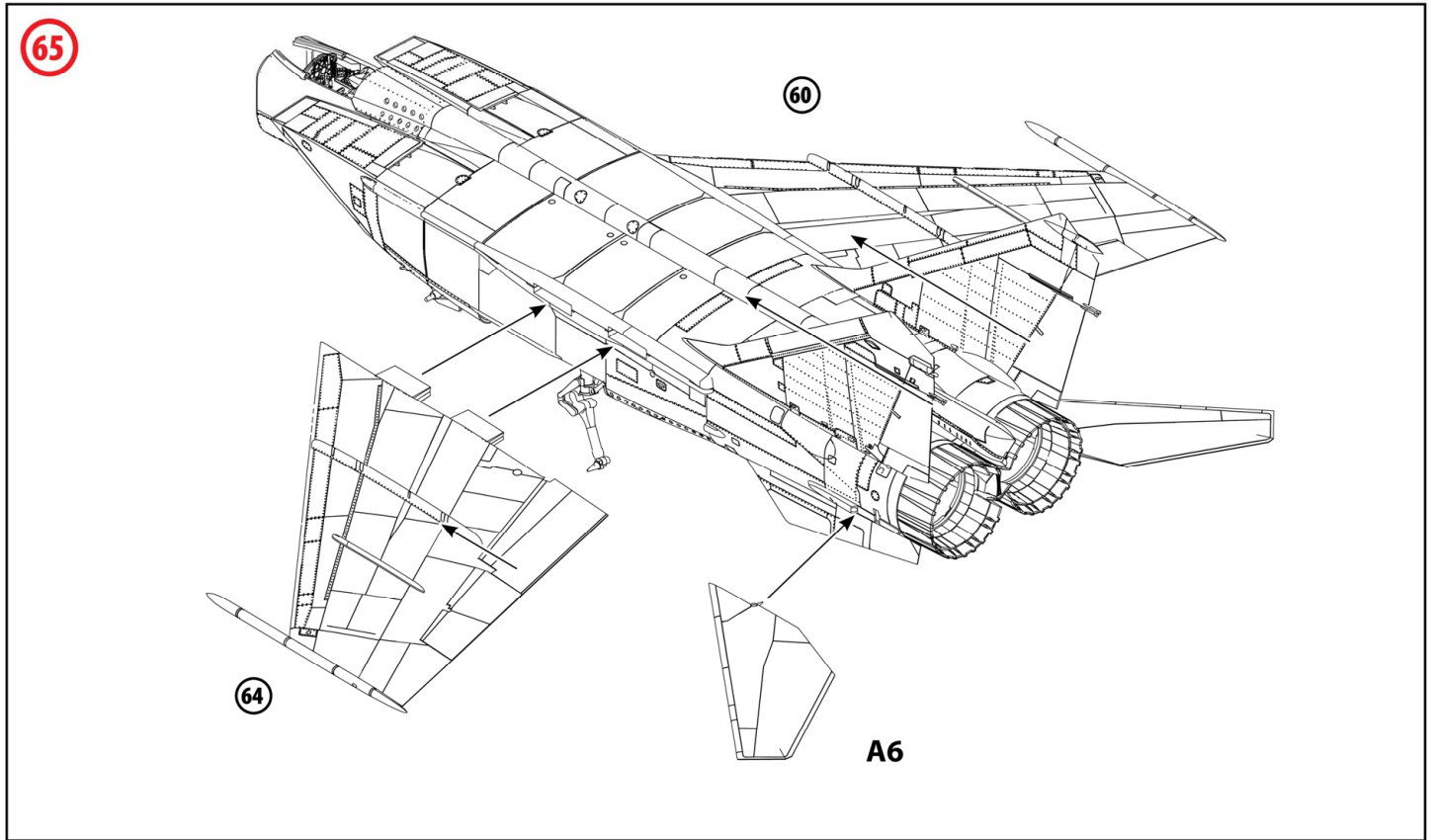

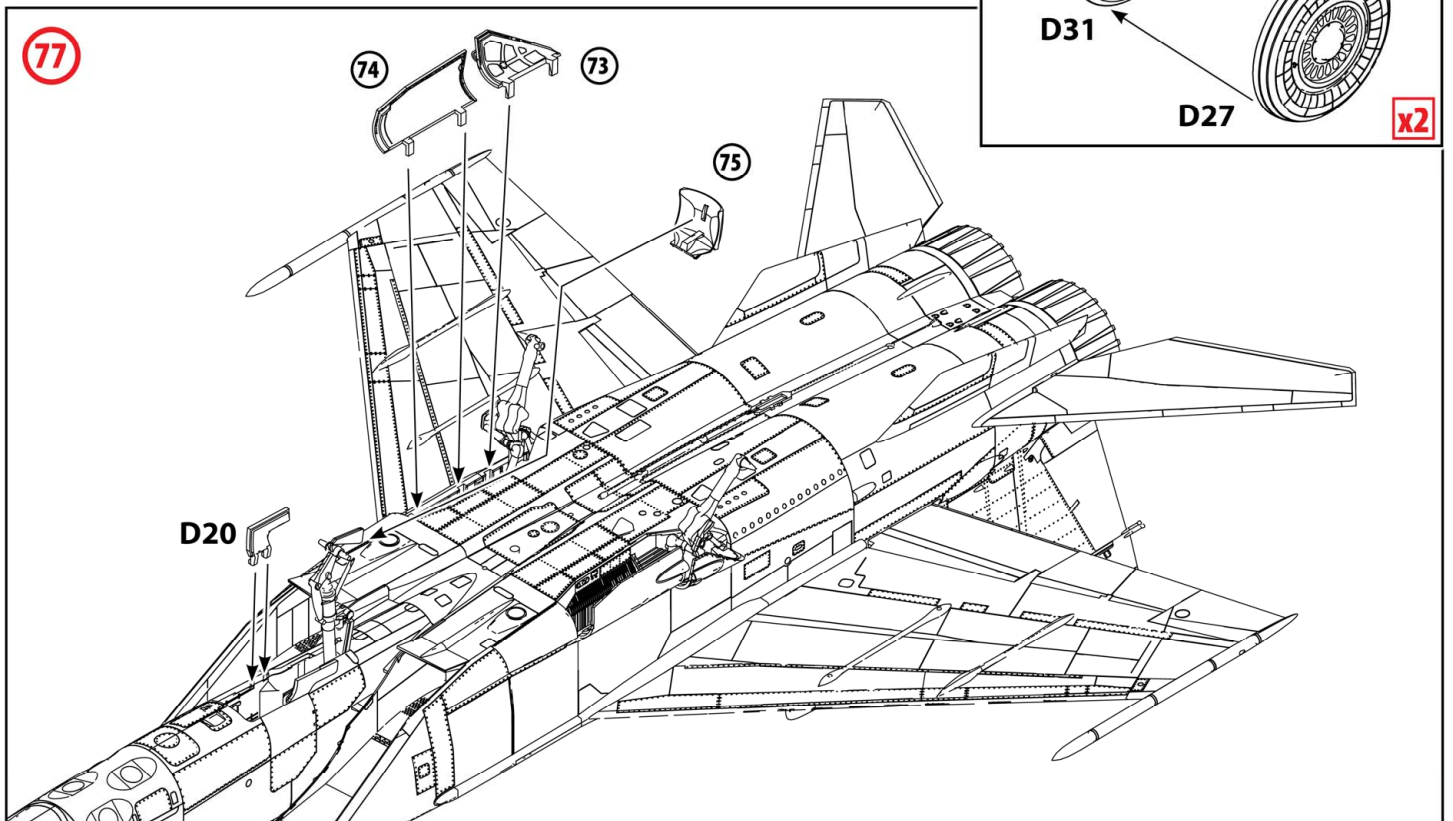
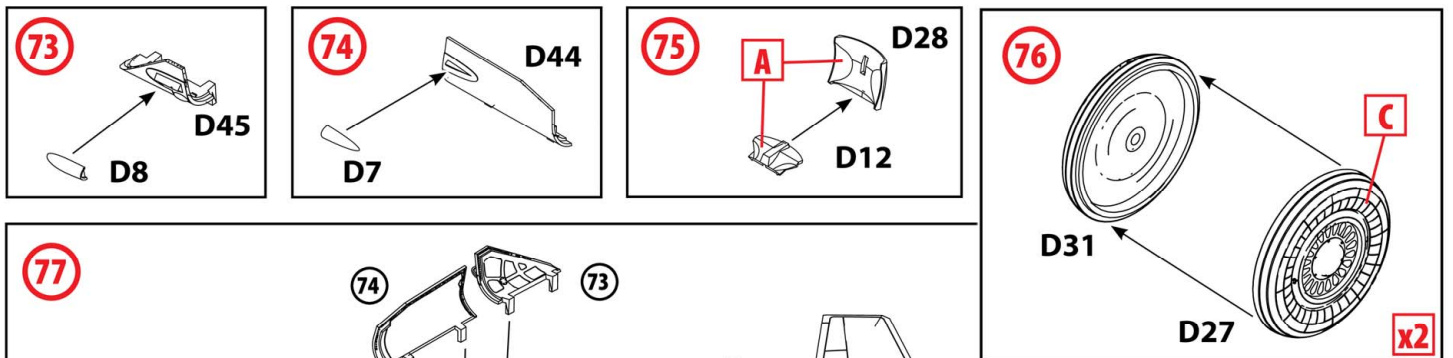
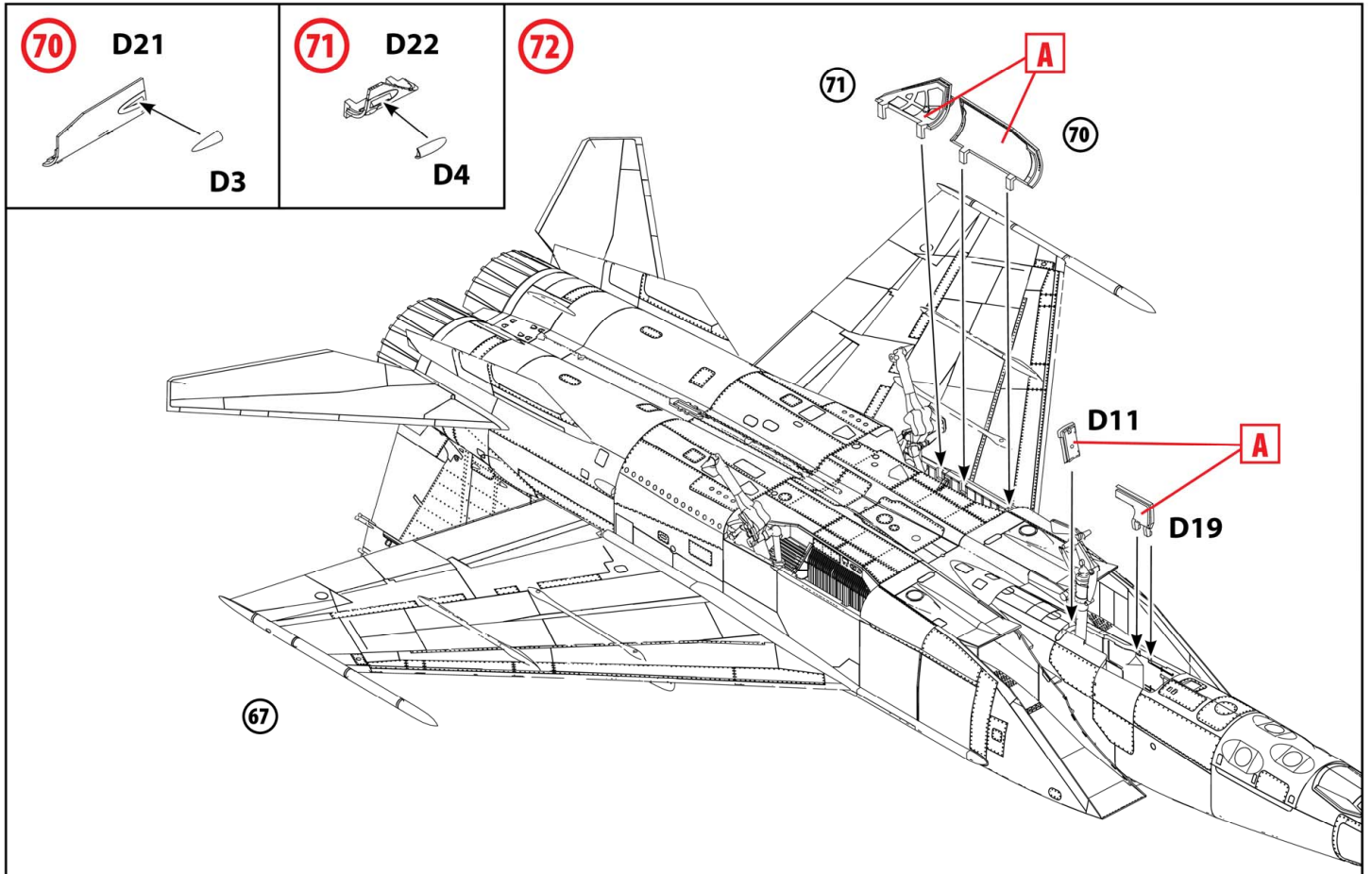

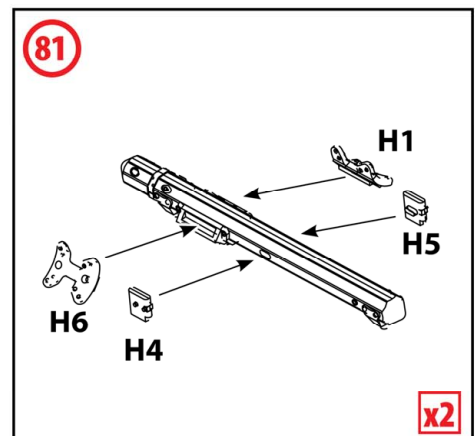
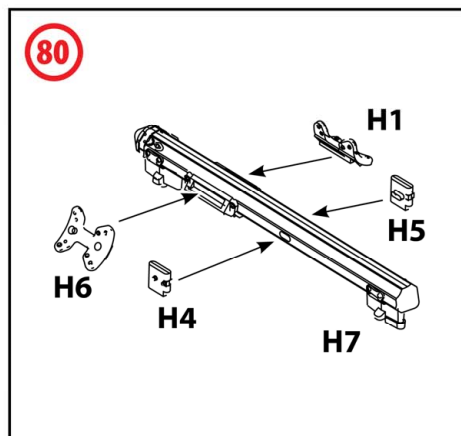
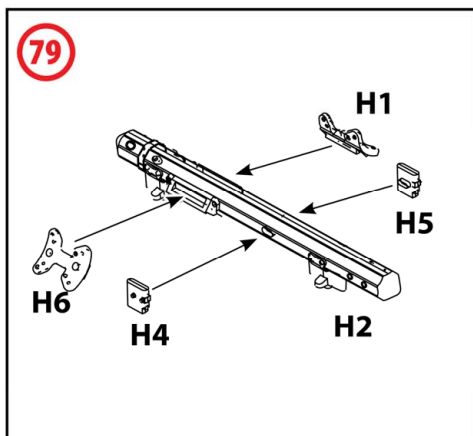
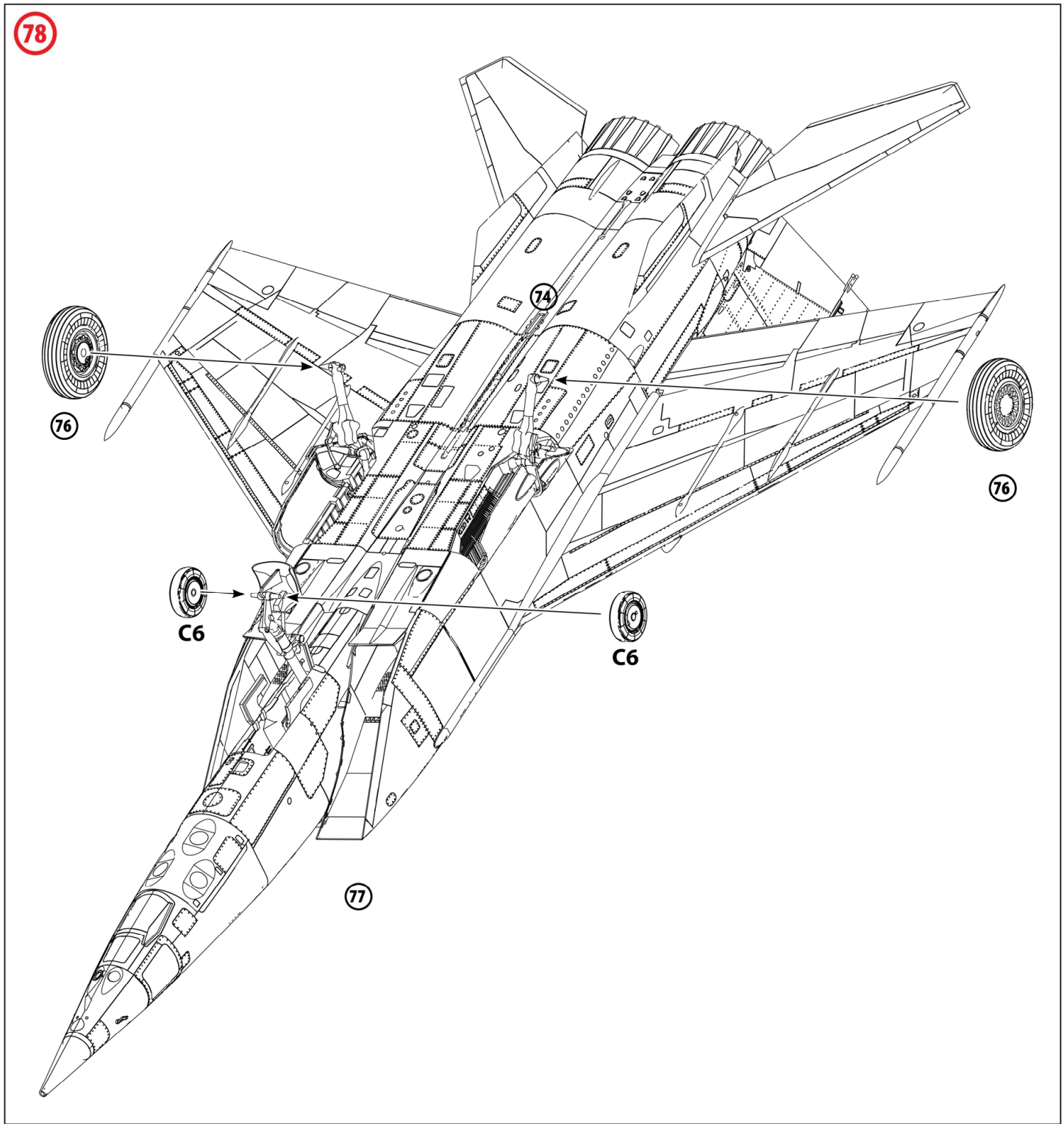

x2

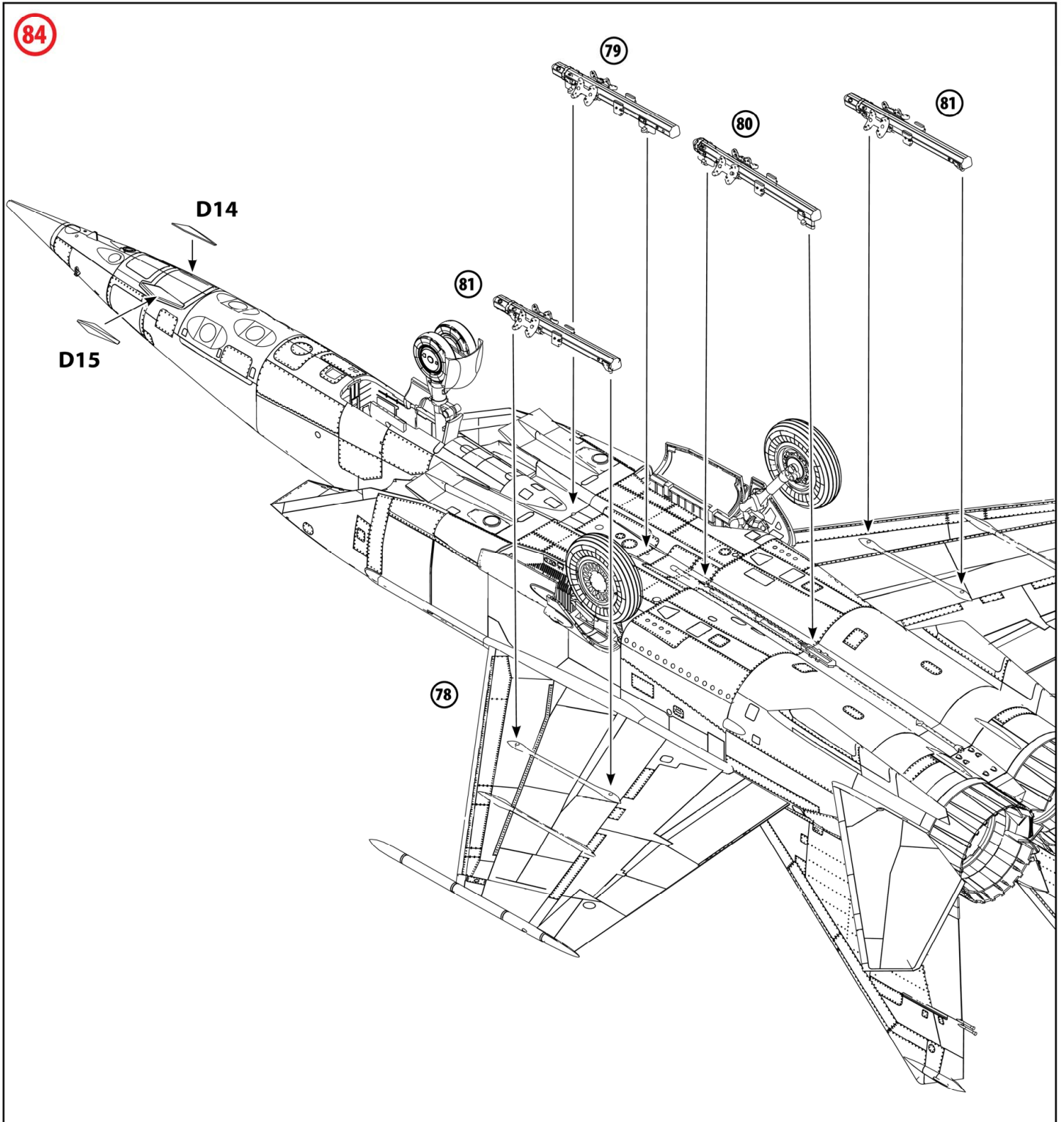
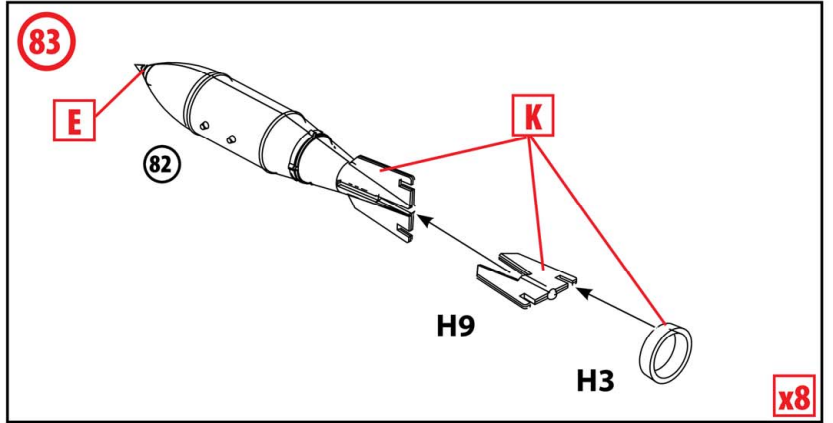
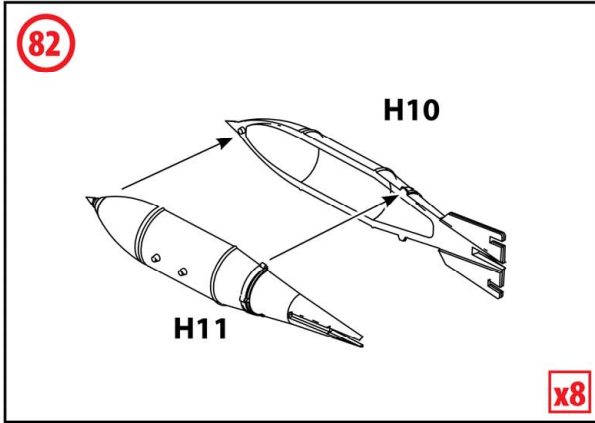

85

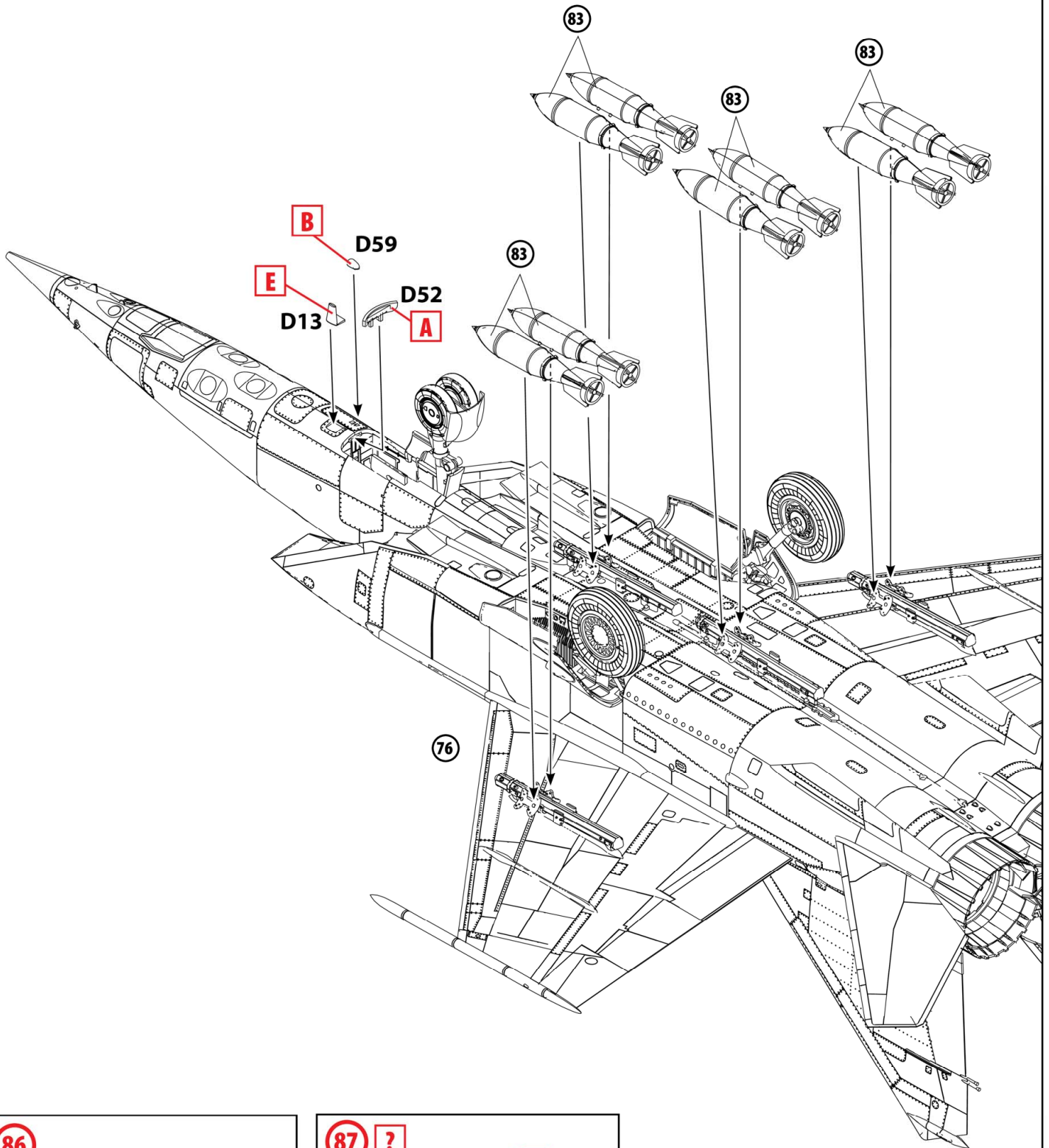

86

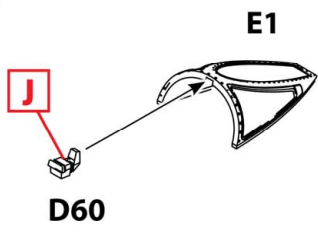

87 ?

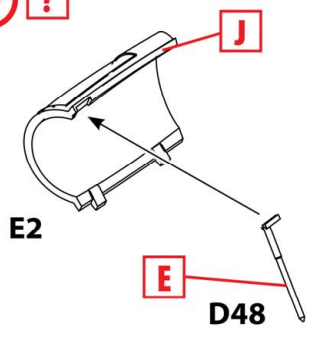

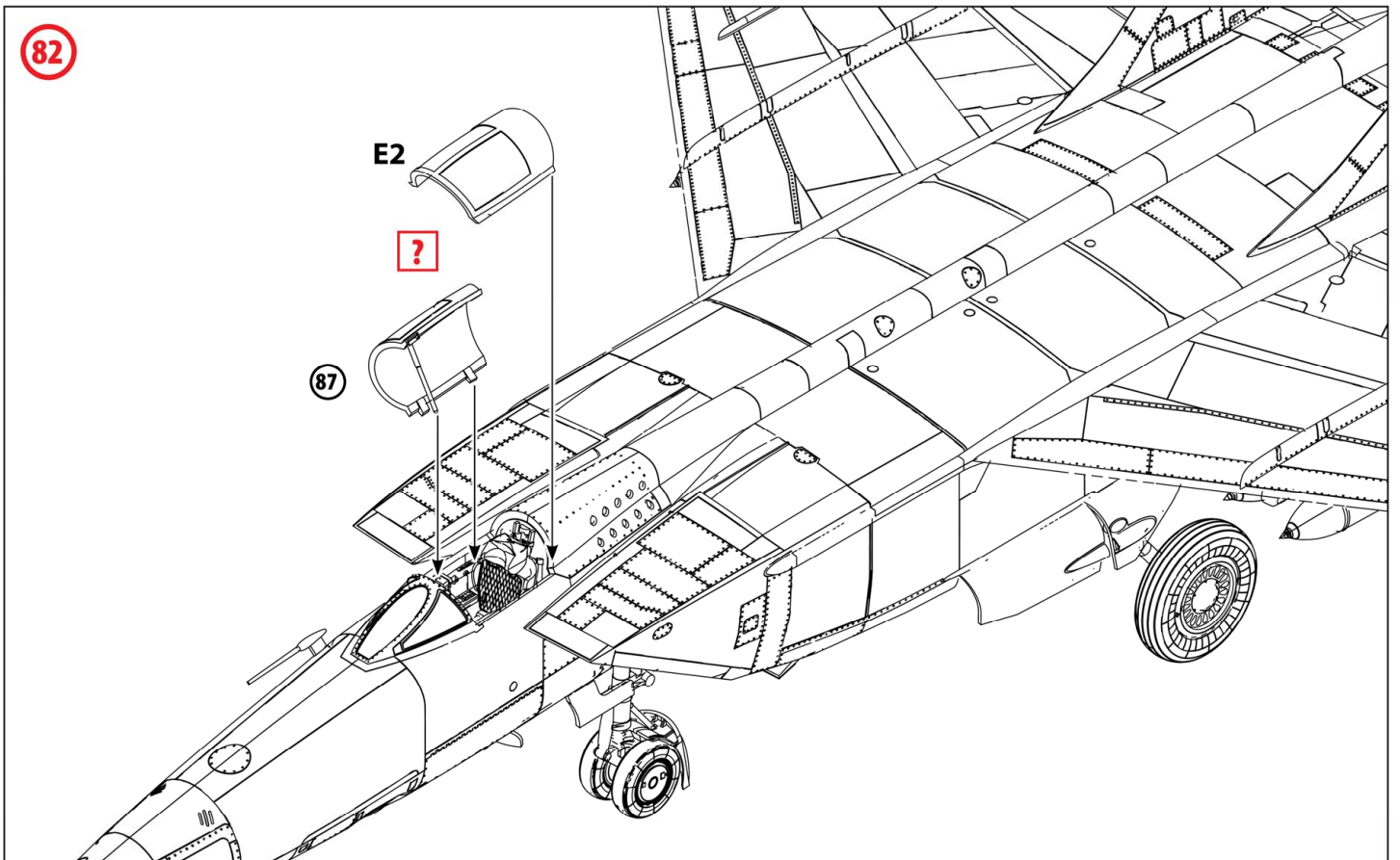
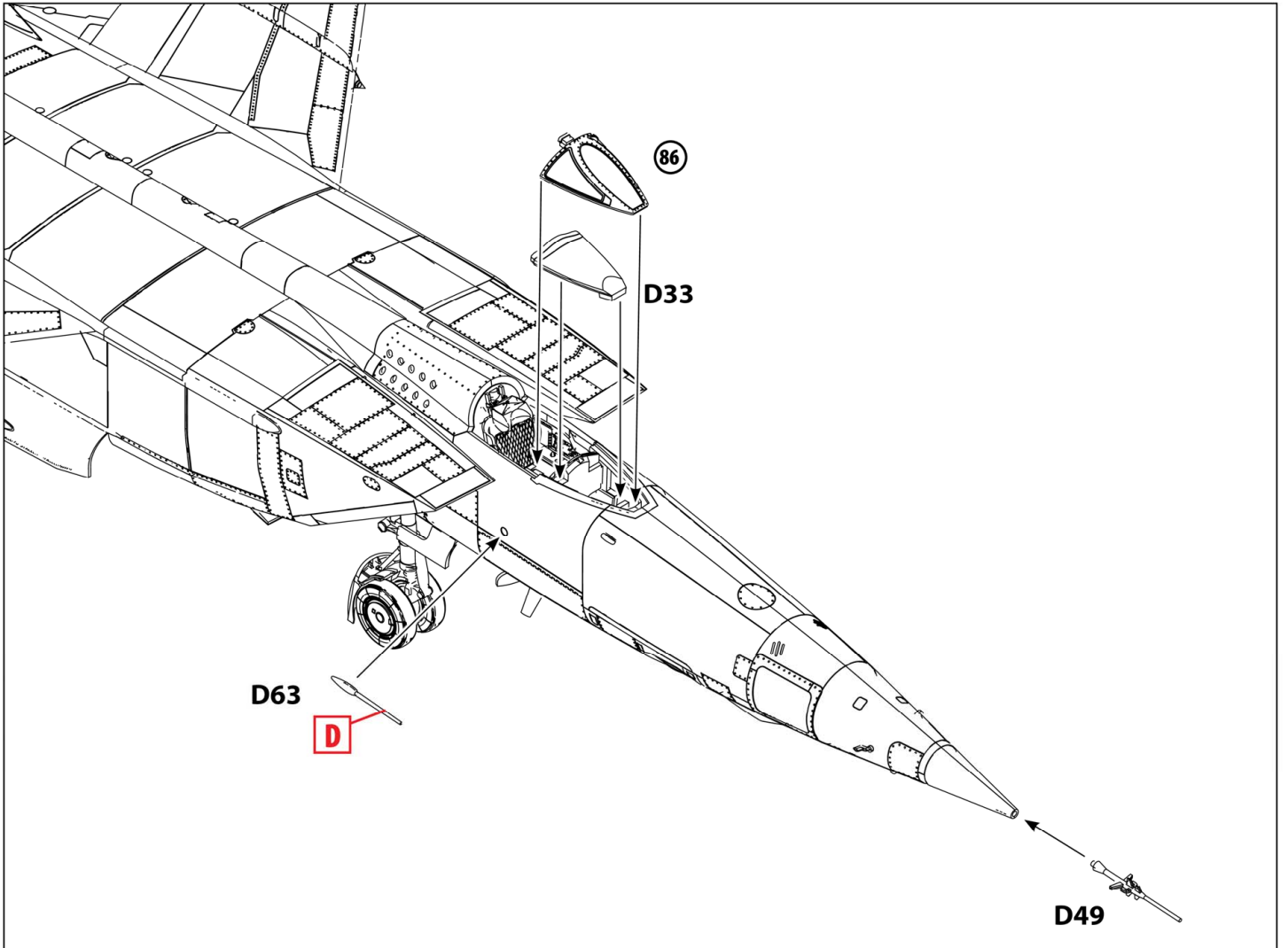

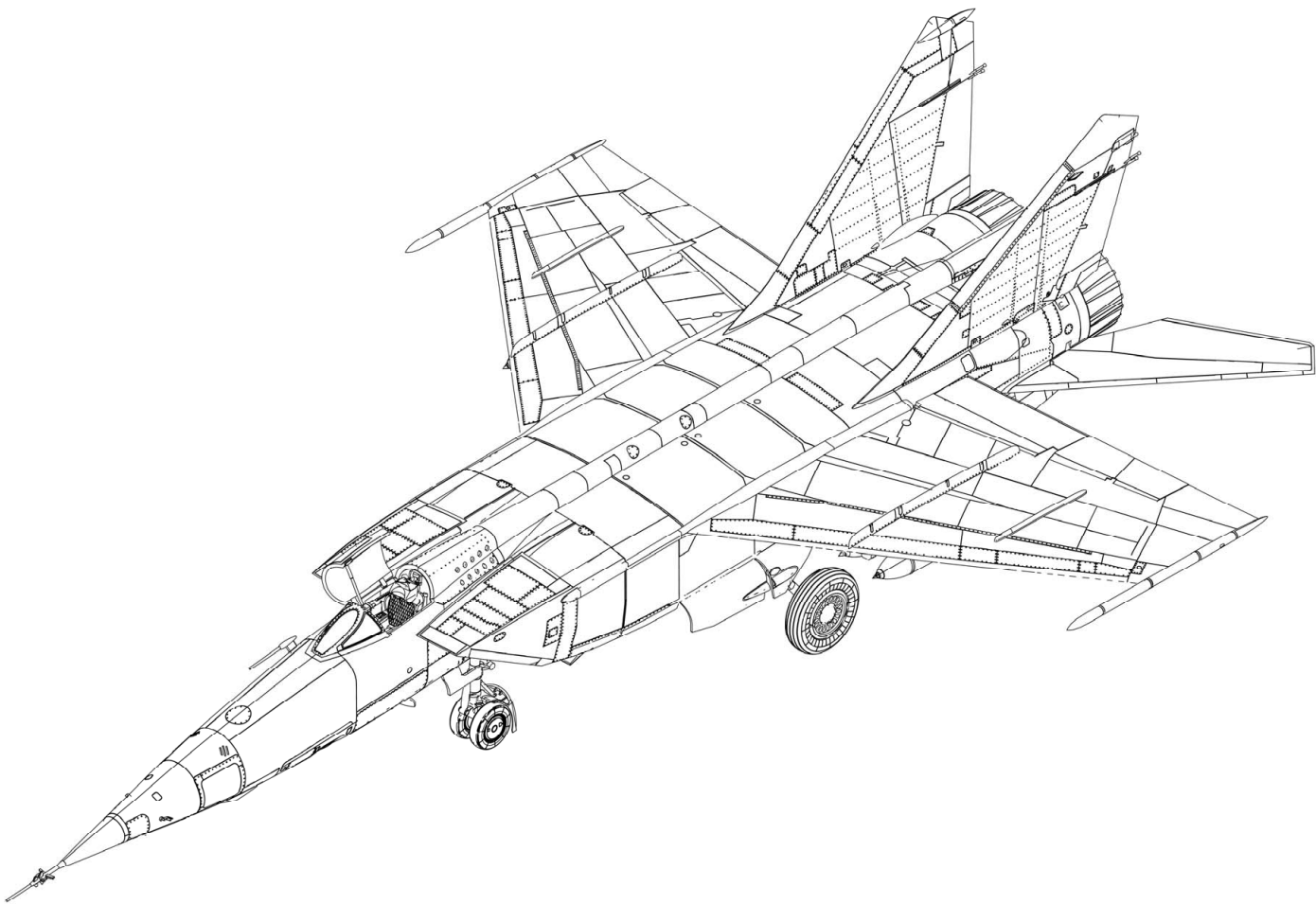

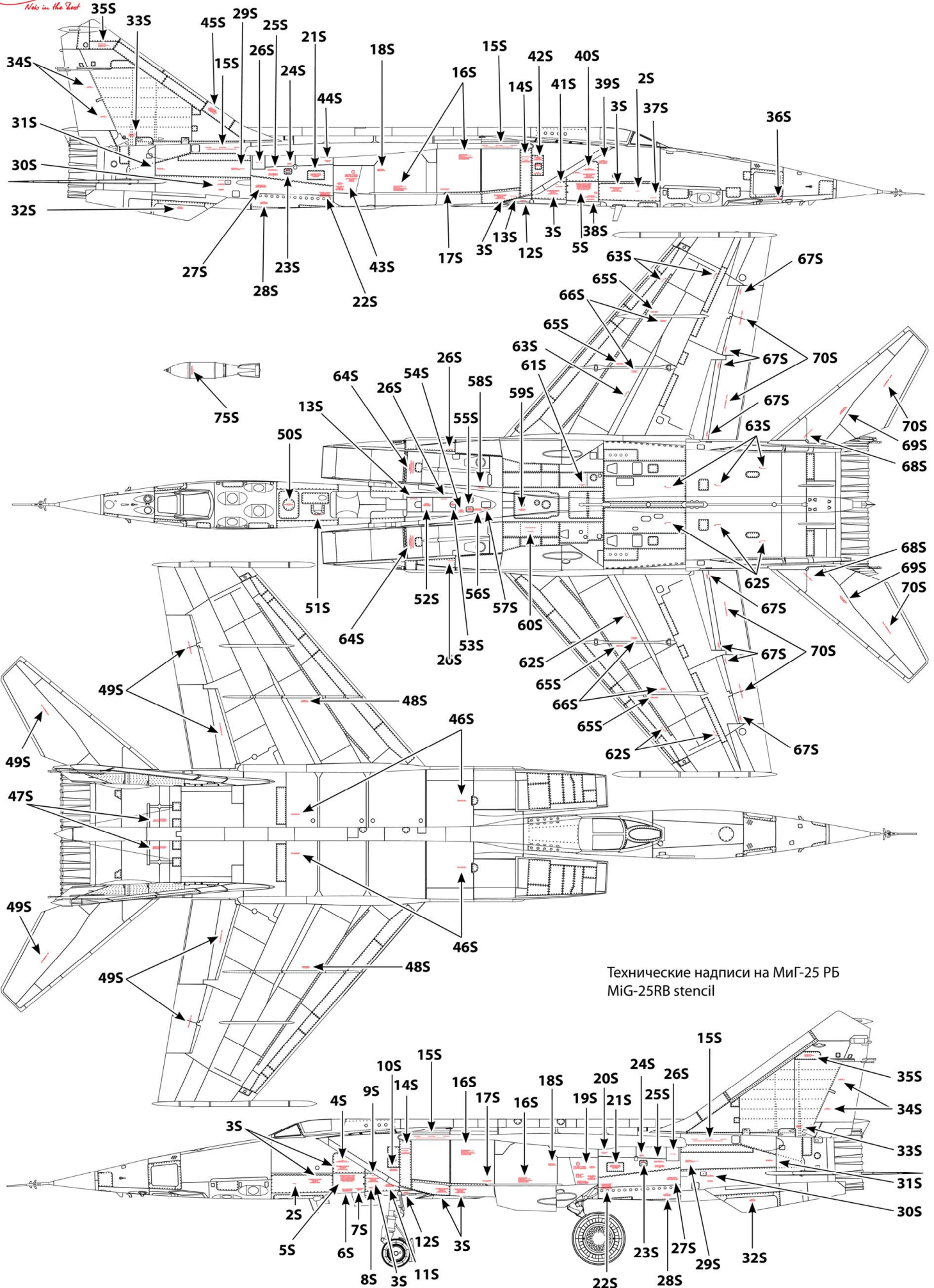

Технические надписи на МиГ-25 РБ
MiG-25RB stencil

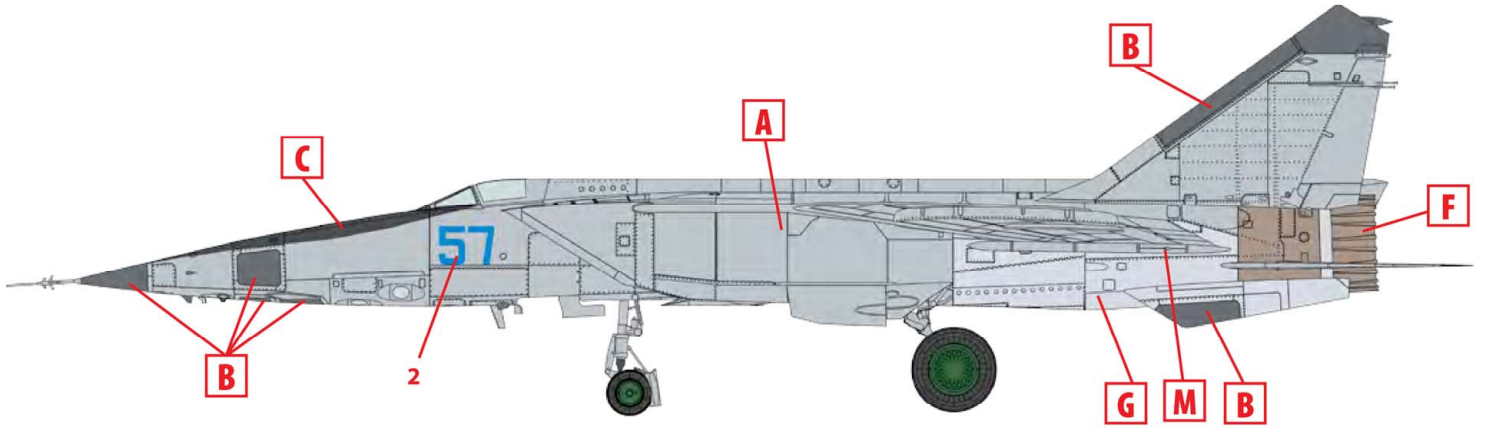

1. МиГ-25РБ, 154-й ОАО, аэродром Каиро-Уэст (АРЕ), май 1974 г.
 MiG-25RB, 154th Independent Air Detachment, Cairo-West (ARE), May 1974

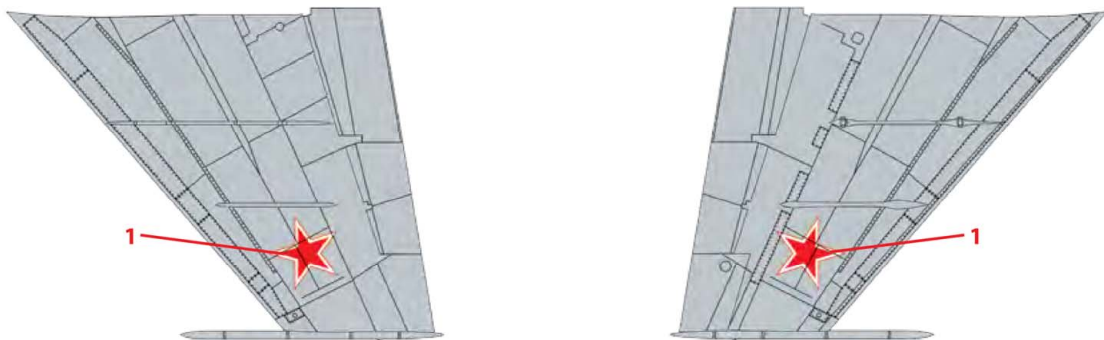
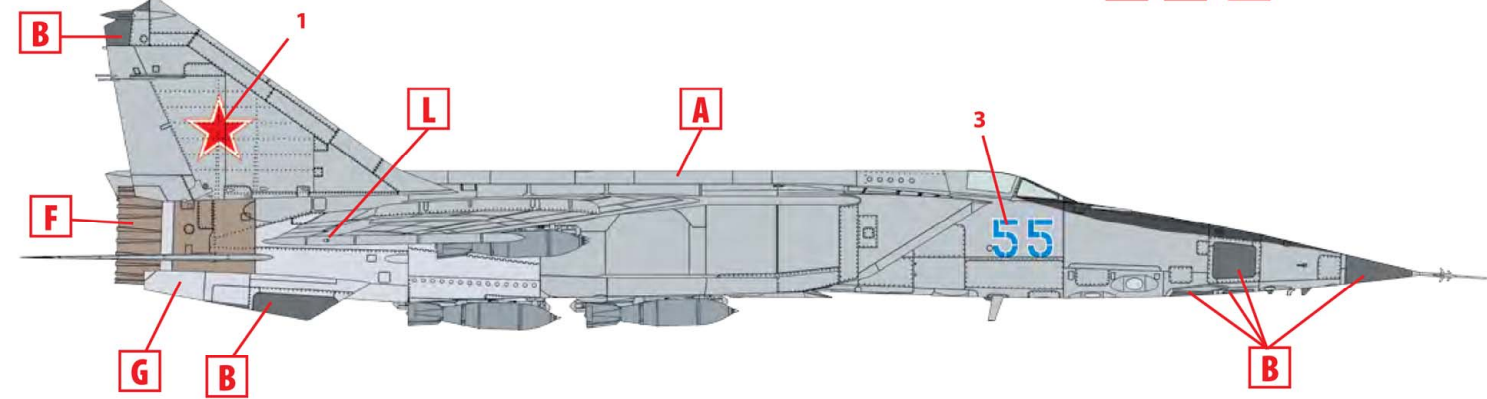
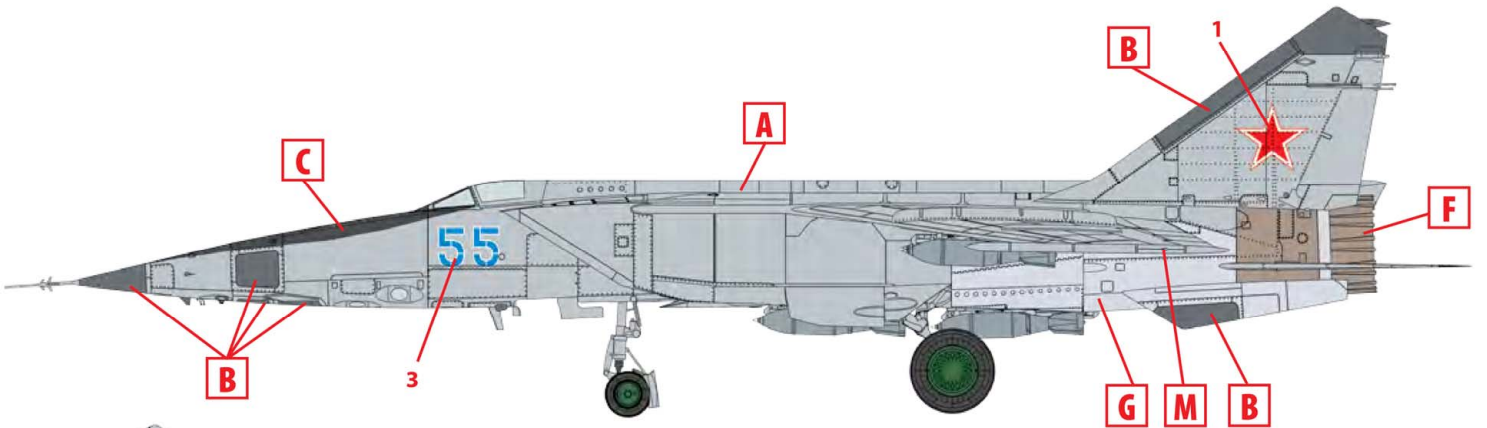

2. МиГ-25РБ, ВВС СССР, конец 70-х г.
 MiG-25RB, Soviet Air Force, late 70s

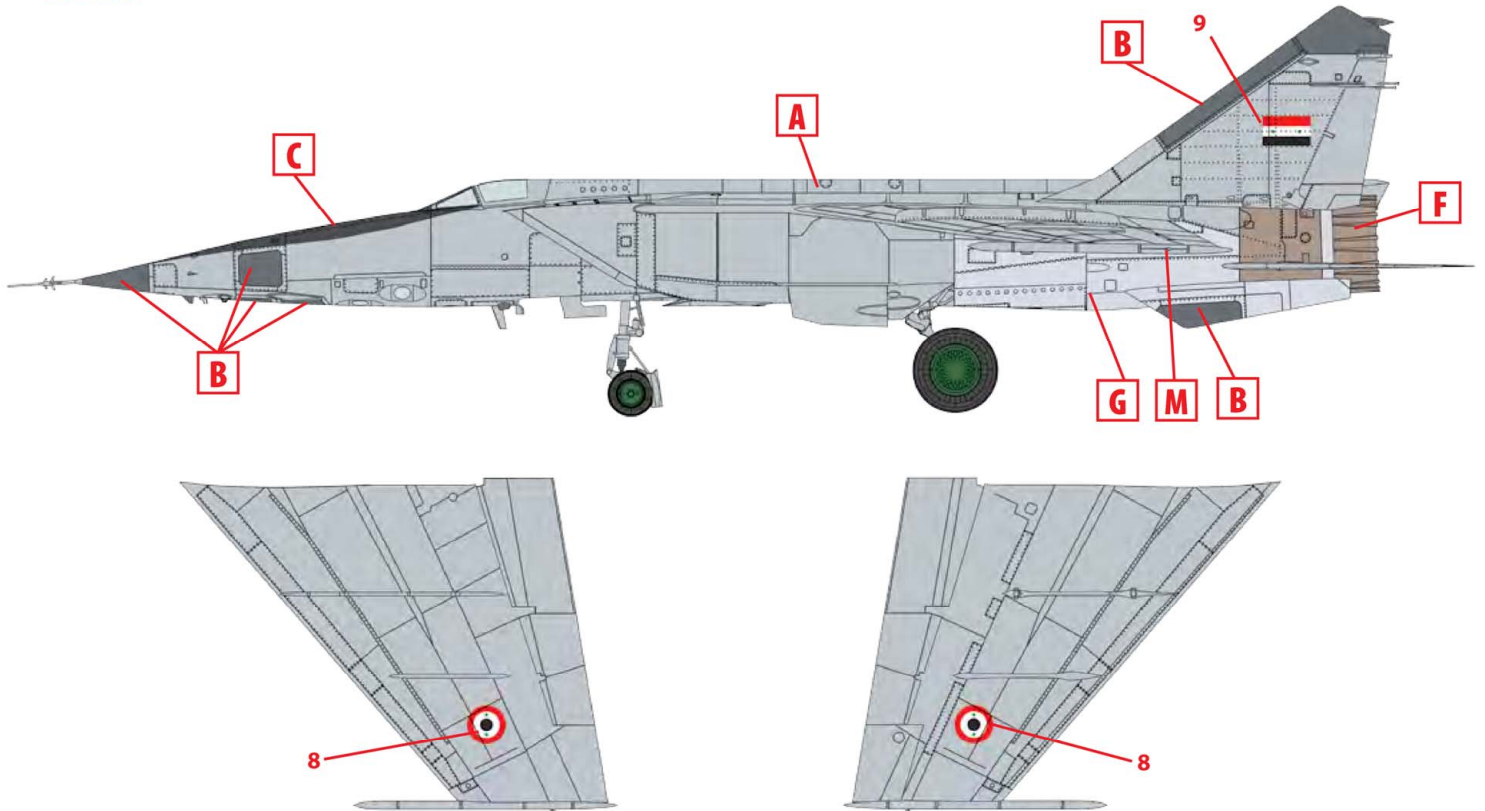

3. МиГ-25РБ, 63-й ОАО, ОАР, 1971-1972 г.
 MiG-25RB, 63d Independent Air Detachment, UAR, 1971-1972

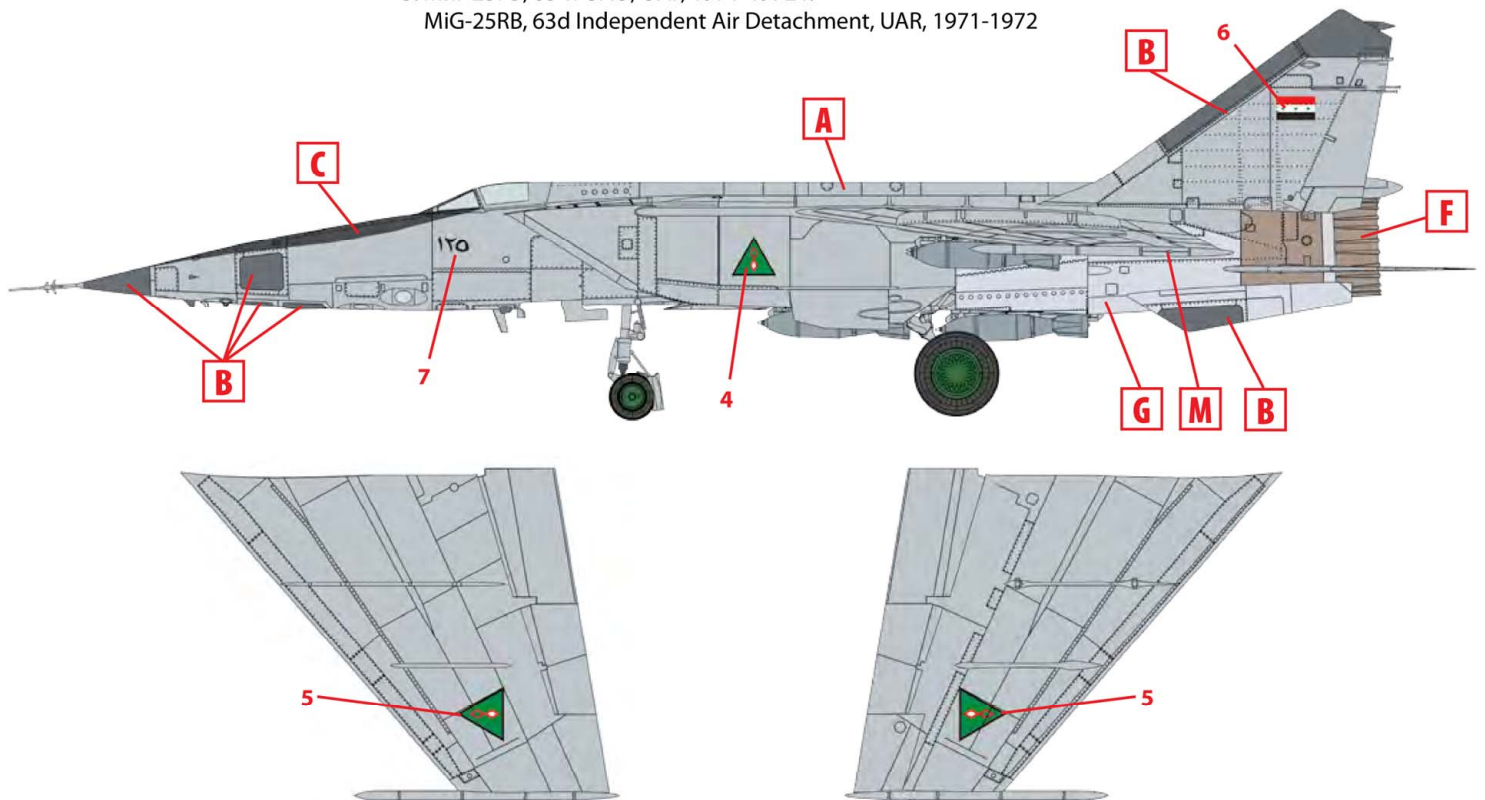

4. МиГ-25РБ (поздних серий), ВВС Ирака, 1980 г.
 MiG-25RB (late production), Iraqi Air Force, 1980

ООО ICM Холдинг
 ул. Бориспольская 9, строение 64,
 02099, Киев, Украина
 Тел./факс: +38(044) 369 54 12
 E-mail: export@icm.com.ua



ICM Holding
 Borispolskaya, 9, build. 64,
 02099, Kiev, Ukraine
 Tel./Fax: +38(044) 369 54 12
 E-mail: export@icm.com.ua