

**B** Hawker Sea Hurricane Mk.IB  
No.804 Naval Air Squadron, Fleet Air Arm, HMS Eagle, 1941.

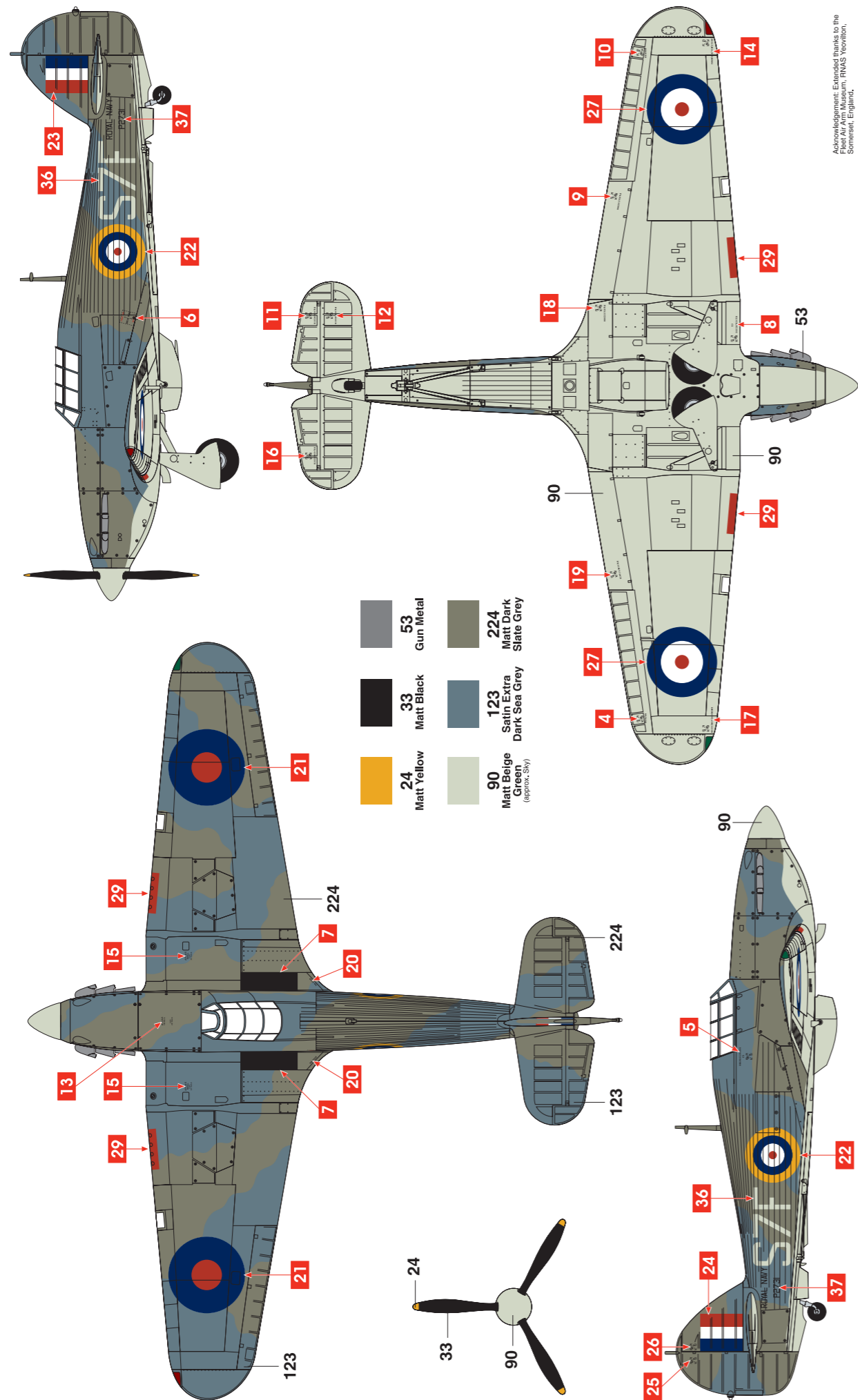

# 1:48 Hawker Sea Hurricane Mk.IB

A05134 SCALE MODEL CONSTRUCTION KIT | Wingspan: 255mm Fuselage Length: 200mm | Two Decal Schemes Included

**GB** Although often overshadowed by the Supermarine Spitfire, the Hawker Hurricane was in fact the RAF's most vital fighter during the early years of the Second World War. Many of these tough, partly fabric covered monoplane fighters went with the British Expeditionary Force to France in early 1940, and once the Blitzkrieg began they put in a valiant defence against the numerically superior Luftwaffe. Although slower than the Messerschmitt Bf109 and with a less destructive armament, the Hurricane was able to turn tighter, and absorb considerable punishment. During the Battle of Britain it was the RAF's most numerous fighter, mainly tasked with attacking the German bombers and many aces such as Robert Stanford-Tuck, Douglas Bader and later Pat Pattle gained considerable scores with the Hurricane. After the Battle of Britain ended Hurricanes were used across the world, from the Middle East to Russia and even aboard aircraft carriers as the Sea Hurricane. But the summer of 1940 will always be seen as the Hurricane's finest hour.

**FR** Le Hawker Hurricane, même si souvent éclipsé par le Supermarine Spitfire, était en fait le chasseur le plus important de la RAF pendant les premières années de la Deuxième Guerre mondiale. De nombreux exemplaires de ces avions de chasse monoplans en partie recouverts de tissu accompagnèrent le Corps expéditionnaire britannique en France début 1940. Une fois la blitzkrieg commencée, ils se défendirent vaillamment contre les avions plus nombreux de la Luftwaffe. Bien que moins rapide que le Messerschmitt Bf109 et muni d'un armement moins destructeur, le Hurricane pouvait effectuer des virages serrés et subir des dégâts considérables. Pendant la bataille d'Angleterre, c'était le chasseur le plus nombreux de la RAF chargé surtout d'attaquer les bombardiers allemands; des pilotes de chasse dont Robert Stanford-Tuck, Douglas Bader et Pat Pattle plus tard remportèrent de nombreuses victoires avec leur Hurricane. Après la fin de la bataille, les Hurricane servirent partout dans le monde, du Moyen-Orient jusqu'en Russie et furent même embarqués sur porte-avions sous le nom de Sea Hurricane. Mais l'été de 1940 sera toujours considéré comme 'l'heure de gloire' du Hurricane.

**DE** Obwohl vielfach von der Supermarine Spitfire in den Schatten gedrängt, war die Hawker Hurricane in den frühen Jahren des Zweiten Weltkriegs unzweifelhaft das entscheidendste Jagdflugzeug der RAF. Viele dieser strapazierfähigen, teilweise noch stoffbezogenen Eindeckerjagdflugzeuge wurden vom britischen Expeditionskorps im frühen Jahresverlauf 1940 eingesetzt. Am Beginn des Blitzkriegs boten sie der zahlenmäßig überlegenen Luftwaffe zähen Widerstand. Obwohl langsamer und mit weniger durchschlagskräftigen Waffen ausgestattet als die Messerschmitt Bf109, konnte die Hurricane enger wenden und sich auch noch mit relativ schwerer Beschädigung in der Luft halten. In der Luftschlacht um England bildete sie zahlenmäßig den größten Teil der Jagdflugzeuge der RAF. Mit den Hurricanes wurden vor allem die Bomber der Luftwaffe angegriffen, und viele Fliegerasse wie etwa Robert Stanford-Tuck, Douglas Bader und später Pat Pattle erzielten damit beträchtliche Abschusszahlen. Nach dem Ende der Luftschlacht wurde die Hurricane nahezu überall auf der Welt eingesetzt, vom Nahen Osten bis zur Sowjetunion; als Sea Hurricane operierte sie sogar von Flugzeugträgern aus. Der Sommer 1940 wird aber sicherlich immer als Sternstunde der Hurricane angesehen werden.

**ES** Aunque con frecuencia se vio eclipsado por el Supermarine Spitfire, el Hawker Hurricane fue, en realidad, el caza más vital para la RAF durante los primeros años de la Segunda Guerra Mundial. Muchos de estos robustos monoplanos, con recubrimiento en parte textil, entraron en Francia con la Fuerza Expedicionaria británica a comienzos de 1940 y, tras el comienzo de la guerra relámpago, opusieron una valerosa defensa contra la superioridad numérica de la Luftwaffe. A pesar de ser más lento que el Messerschmitt Bf109 y contar con menor capacidad destructiva en su armamento, el Hurricane tenía más capacidad de giro y podía soportar importantes daños. Durante la Batalla de Inglaterra fue el caza más numeroso de la RAF, con la misión principal de atacar a los bombarderos alemanes. Muchos ases de la aviación, como Robert Stanford-Tuck, Douglas Bader y, más tarde, Pat Pattle lograron numerosas victorias a los mandos del Hurricane. Una vez finalizada la Batalla de Inglaterra, los Hurricane se utilizaron en todos los rincones del mundo, desde Oriente Medio hasta Rusia, e incluso a bordo de portaaviones, en la versión Sea Hurricane. Sin embargo, siempre se recordará el verano de 1940 como el momento estelar del Hurricane.

**SE** Hawker Hurricane överskuggades ofta av Supermarine Spitfire, men var faktiskt RAF:s viktigaste jaktplan under andra världskrigets tidiga fas. Flera av dessa robusta, men delvis dukklädda, monoplan flög med British Expeditionary Force till Frankrike i början på 1940, och så snart blitzkriget inleddes utgjorde de ett betydande försvar mot det numerärt överlägsna Luftwaffe. Trots att Hurricane var långsammare än Messerschmitt Bf109 och hade en mindre destruktiv bestyckning kunde planet svänga snävare och absorbera omfattande skador. Under Slaget om Storbritannien var Hurricane det jaktplan som RAF använde flitigast, och dess uppgift bestod då i att attackera tyska bombplan. Flera flygaräss som Robert Stanford-Tuck, Douglas Bader och senare Pat Pattle skördade stora framgångar med Hurricane. Efter Slaget om Storbritannien användes Hurricanes-planet över hela världen, från Mellanöstern till Ryssland, och även på hangarfartyg i form av Sea Hurricane-plan, men sommaren 1940 anses ändå vara höjdpunkten för Hurricanes insatser.

Airfix would like to thank Hawker Restorations and Peter Vacher of <http://www.hurricanedisplays.co.uk/> for their help with the development of this model.



**FOR BEST RESULTS:**

Surfaces to be painted should be clean — before parts are removed from the sprue, wash in warm, soapy water, rinse and dry thoroughly. Stir paints thoroughly before use.

**PLEASE NOTE:**

Some parts in the kit may not be required to build the model specified.



**Specification:**

Speed: 328 mph (529 m) at 20,000 ft (6,095m)
Range: 600 miles (965 km)
Wingspan: 40 ft 0 in (12.19m)
Length: 31 ft 4 in (9.55 m)
Armament: 8 x .303 in machine guns

**Spécification:**

Vitesse : 529 km/h à une altitude de 6.095 m
Autonomie : 965 km
Envergure : 12,19 m
Longueur : 9,55 m
Armement: huit mitrailleuses de 7,7 mm

**Spezifikation:**

Geschwindigkeit: 529 km/h auf 6095 m Flughöhe;
Reichweite: 965 km
Spannweite: 12,19 m
Länge: 9,55 m
Bewaffnung: acht 7,7 mm MG.

**Especificación:**

Velocidad: 529 km/h a 6095 m
Autonomía: 965 km
Envergadura: 12,19 m
Longitud: 9,55 m
Armamento: 8 ametralladoras de 7,7 mm

**Specifikation:**

Hastighet: 529 km/h på 6 095 m höjd
Räckvidd: 965 km
Spännvidd: 12,19 m
Längd: 9,55 m
Bestyckning: 8 st. 7,7 mm-kulsprutor

## ASSEMBLY INSTRUCTIONS

**GB** Study drawings and practice assembly before cementing parts together. Carefully scrape plating and paint from cementing surfaces. All parts are numbered. Paint small parts before assembly. To apply decals cut sheet as required, dip in warm water for a few seconds, slide off backing into position shown. Use in conjunction with box artwork. Not appropriate for children under 36 months of age, due to the presence of small detachable parts.

**FR** Étudier attentivement les dessins et simuler l'assemblage avant de coller les pièces. Gratter soigneusement tout revêtement ou peinture sur les surfaces à coller avant collage. Toutes les pièces sont numérotées. Peindre les petites pièces avant l'assemblage. Pour coller les décalques, découper le motif, le plonger quelques secondes dans de l'eau chaude puis le poser à l'endroit indiqué en décollant le support papier. Utiliser en même temps les illustrations sur la boîte. Ne convient pas à un enfant de moins de 36 mois – présence de petits éléments détachables.

**DE** Vor Verwendung des Klebers Zeichnungen studieren und Zusammenbau üben. Farbe und Plattierung vorsichtig von den Klebeflächen abkratzen. Alle Teile sind nummeriert. Vor Zusammenbau kleine Teile anmalen. Um die Abziehbilder aufzukleben, diese ausschneiden, kurz in warmes Wasser tauchen, dann abziehen und wie abgebildet aufkleben. In Verbindung mit Abbildungen auf Schachtel verwenden. Ungeeignet für Kinder unter 36 Monaten. Kleine Teilchen vorhanden die sich lösen können.

**ES** Estudiar los dibujos y practicar el montaje antes de pegar las piezas. Raspar cuidadosamente el plateado y la pintura en las superficies de contacto antes de pegar las piezas. Todas las piezas están numeradas. Es conveniente pintar las piezas pequeñas antes de su montaje. Para aplicar las calcomanías, cortar la hoja, sumergir en agua tibia durante unos segundos y deslizarlas en la posición debida. Ver ilustraciones en la caja. No conviene a un niño menor de 36 meses, contiene pequeñas piezas que pueden soltarse.

**SE** Studera bilderna noggrant och sätt ihop delarna innan du limmar ihop dem. Skrapa noggrant bort förtorkromning och färg från limmade delar. Alla delarna är numrerade. Mala smadelarna före ihopsättning. Fastsättning av dekaler, klipp arket. Doppa i varmt vatten några sekunder, låt baksidan glida på plats som bilden visar. Används i samband med kartongens handlitografi. Rekommenderas ej för barn under 3 år. Innehåller löstagbara smadelar.

**IT** Studiare i disegni e praticare il montaggio prima di unire insieme i pezzi con l'adesivo. Raschiare attentamente le tracce di smalto e cromatura dalle superfici da unire con adesivo. Tutti i pezzi sono numerati. Colorare i pezzi di piccole dimensioni prima di montarli. Per applicare le decalcomanie, tagliare il foglio secondo il caso, immergere in acqua calda per alcuni secondi, quindi sfilare la decalcomania dalla carta di supporto e piazzarla nella posizione indicata. Usare in congiunzione con l'illustrazione sulla scatola. Non adatto ad un bambino di età inferiore ai 36 mesi dovuto alla presenza di piccoli elementi staccabili.

**NL** Tekeningen bestuderen en delen in elkaar zetten alvorens deze te lijmen. Metaalcoating en lak voorzichtig van lijmvlakken af schrapen. Alle delen zijn genummerd. Kleine delen vóór montage verven. Voor aanbrengen van stickers, gewenste stickers uit vel knippen, een paar seconden in warm water dompelen en dan van schutblad af op afgebeelde plaats schuiven. Hierbij afbeelding op doos raadplegen. Niet geschikt voor kinderen onder 3 jaar, omdat kleine deeltjes gemakkelijk kunnen losraken.

**DK** Tegningerne bør studeres, og man bør øve sig i monteringen, før delene limes sammen. Pladestykker og maling skal omhyggeligt fjernes fra kloveoverfladerne. Alle dele er nummererede. Små dele skal males før monteringen. Overføringsbillederne anvendes ved at tilklippe arket efter behov. Og dyppe det i varmt vand i nogle få sekunder. Underlaget glides af og anbringes i den viste position. Påføres ifølge brugsanvisningerne på oesken. Ikke til børn under 3 år, forekomst af små løse elementer.

**PT** Estudar atentamente os desenhos e experimentar a montagem. Raspar cuidadosamente as superfícies de modo a eliminar pintura e revestimento antes de colar. Todas as peças estão numeradas. Pintar as pequenas peças antes de colar. Para aplicar as decalcomanias, cortar as folhas e mergulhar em água morna por alguns segundos, depois deslizar e aplicar no respectivo lugar, como indicado nas ilustrações na caixa. Não convém a uma criança de menos de 36 meses devido à presença de pequenos elementos destacáveis.

**FI** Tutustu piirroksiin ja harjoittele kokoamista ennen kuin liimaat osat yhteen. Raaputa metallipäällyste ja maali varovasti pois liimattavilta pinoilta. Kaikki osat on numeroitu. Maalaa pienet osat ennen kokoamista. Siirtokuvien kiinnittämiseksi leikkaa ne arkista tarpeen mukaan. Kasta kuva lämpimään veteen muutaman sekunnin ajaksi, anna takapuolen liukua kuvalle osoitettuun kohtaan. Käytetään yhdessä laatikon kuvituksen kanssa. Ei suositella alle kolmivuotiaille lapsille. Pajon irrotettavia pikkuosia.

**PL** Przed przystąpieniem do sklejania przestuduj uważnie rysunki i przećwicz składanie części. Osłóżnie zeskrób ze sklepanych powierzchni powłokę i farbę. Wszystkie części są ponumerowane. Drobne części pomaluj przed ich złożeniem. Celem przeniesienia odbitki wytnij ją z arkusza, zanurz na kilka sekund w letniej wodzie i zsuń z podłoża na wymagane miejsce. Używaj w połączeniu ze wzorami na pudełku. W związku z obecnością wielu drobnych, rozbiernych części, niestosowne dla dzieci poniżej 3 lat.

**EL** Μελετήστε προσεκτικά τα σχέδια και συναρμολογήστε για πρώτη φορά τα κομμάτια χωρίς να τα συγκολλήσετε. Αφαιρέστε επιμελώς τη μεταλλική μπιγιά και την πλαστική βαφή από τις επιφάνειες τις οποίες θα συγκολλήσετε ζύνοντάς τις προσεκτικά. Όλα τα κομμάτια είναι αριθμημένα. Χρωματίσετε τα μικρά κομμάτια πριν από τη συναρμολόγηση. Για να κολλήσετε τις χαλκομανίες, κόψτε γύρω από το σχέδιο όπως απαιτείται, βυθίστε το μερικά δευτερόλεπτα σε χλιαρό νερό και μετά τοποθετήστε το στη θέση που υποδεικνύεται, αφαιρώντας τη μεμβράνη που το καλύπτει. Λάβετε υπόψη σας ταυτόχρονα την εικονογράφηση του κουτιού. Ακατάλληλο για παιδιά ηλικίας κάτω των 36 μηνών λόγω ύπαρξης μικρών κομματιών που αποσπώνται.

**A Hawker Sea Hurricane Mk.IB**  
Aircraft flown by Lieutenant Richard John (Dickie) Cork (DSO & DSC), No.880 Naval Air Squadron, Fleet Air Arm, HMS Indomitable, Operation "Ironclad", Diego Suarez, Madagascar, May 1942.

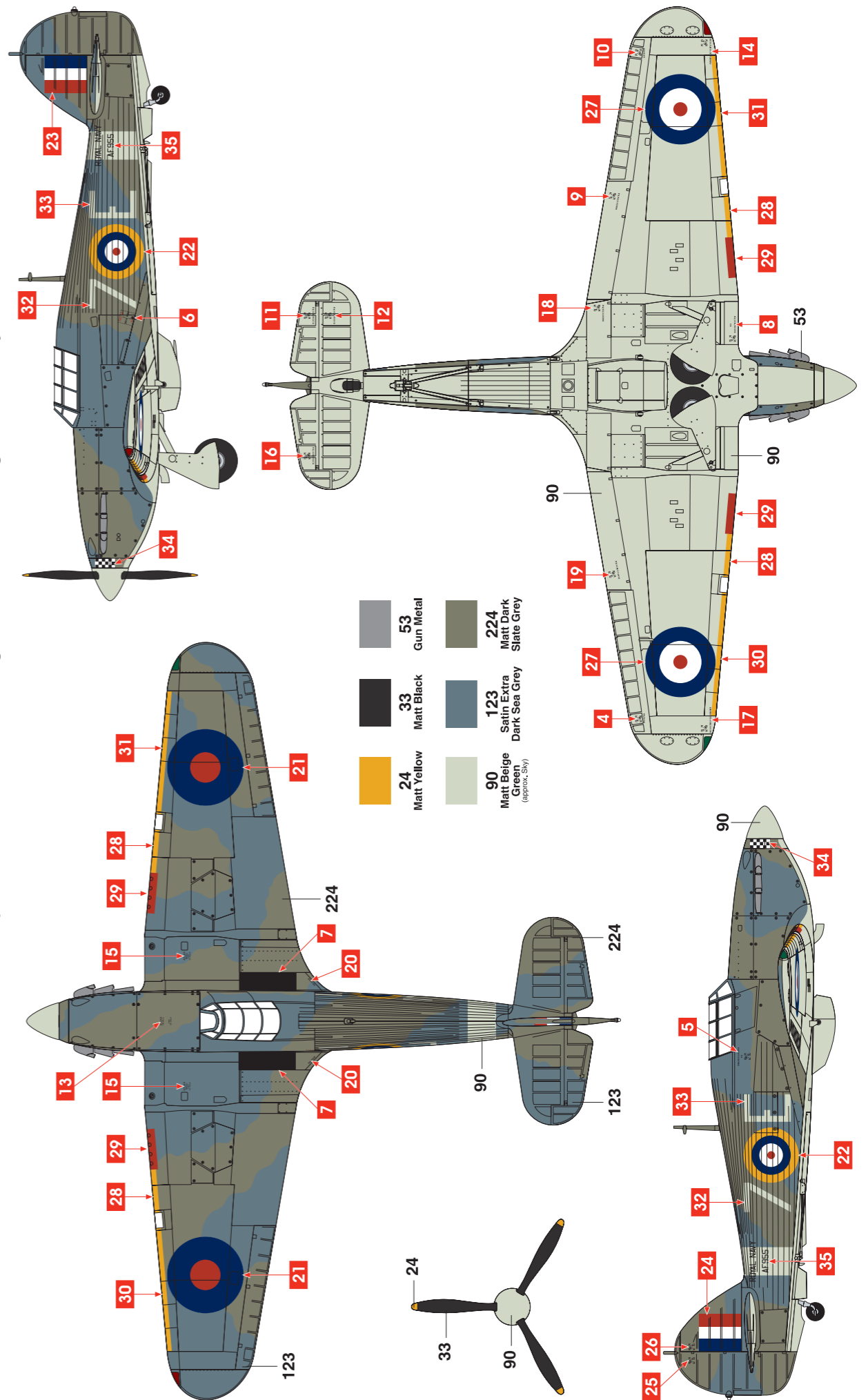

## ASSEMBLY ICON INSTRUCTIONS

<p><b>Assembly phase</b> Phase de montage Montagephase Fase de montaje Monteringsfasen Fase di montaggio Montagefase Fase de montagem Monteringsfase Kokoamisvaihe Faza składowania Φάση συναρμολόγησης</p>	<p><b>Cement</b> Coller Kleben Pegar Limma Incollare Lijmen Colar Klæbes Liimaa Kleić Συγκολλήστε</p>	<p><b>Do not cement together</b> No pas coller Nicht kleben No pegar Limma inte Non incollare Niet lijmen Nào colar Sikal ikke klæbes Älä liimaa Nie kleić Μη συγκολλήσετε</p>	<p><b>Indicates final location</b> Indique l'emplacement final Zeigt Endposition Indica la ubicación definitiva Anger sluttmonteringsplats Sede di montaggio finale Geeft uiteindelijke locatie aan Indica localização final Viser endelig placering Osoittaa loppulisen sijainnin Oznacza miejsce docelowe Υποδεικνύει τελική τοποθεσία</p>	<p><b>Alternative part(s) provided</b> Autre(s) pièce(s) fournie(s) Ersatzteil(e) mitgeliefert Se incluye(n) pieza(s) alternativa(s) Alternativ(a) del(ar) ingår Uno o più componenti alternativi forniti Alternatieve onderdelen meegeleverd Peça(s) alternativa(s) fornecida(s) Alternativ(e) del(e) medfølger Vaihtoehdotset osat pakkauskassa Dostępne części zamiennie Παρέχονται εναλλακτικά κομμάτια</p>	<p><b>Repeat this operation</b> Répéter l'opération Vorgang wiederholen Repètir la operación Upprepa åtgärden Ripetere l'operazione De verrichting herhalen Repètir a operação Manövern gentages Toista toimenpite Powtórzyc operację Επανάλάβετε τη διαδικασία</p>	
<p><b>Decals</b> Décalcomanias Abziehbild Calcomanias Dekaler Decalcomanie Bilddoverføring Siirtokuvat Kalkomanie Χαλκομανίες</p>	<p><b>Crystal part</b> Pièce cristal Kristallteil Pieza de cristal Kristalldel Pezzo cristallo Kristallen onderdeel Peça de cristal Kryсталлыккe Kryształosa Część kryształowa Κομμάτι κρυστάλλου</p>	<p><b>Weight</b> Lester Beschweren Lastrar Belasta Applicare un peso Verzwaren Remova limando Páfar vægt Aseta vastapaino Obciążyc balastem Επιθέστε βάρος</p>	<p><b>Remove by filing</b> Enlever avec une lime Abfeilen Abfeilen Eliminar con lima Ta bort genom att fila Rimuovere con la lima Verwijderen door afvlijen Remova limando Fjern ved at file væk Poista villaamalla Usunąć przy użyciu pilnika Αφαιρέστε λιμόνιας με λίμα</p>	<p><b>Drill or pierce</b> Perçer Durchbohren Perforar Borra Trapanare o forare Boren of doorboren Furar Gennembor Poraa tai puhkaise Wywiercić lub przedziurawić Τρυπήστε</p>	<p><b>Cut</b> Découper Schneiden Cortar Skär Tagliare Snijden Cortar Skær Leikkaa Przeciąć Κόψτε</p>	<p><b>Humbrol paint number</b> No peinture Humbrol Humbrol-Farbnnummer No de pintura Humbrol Humbrol färg nummer No vernice Humbrol Humbrol verfnummer No de pintura Humbrol Humbrol malingsnummer Humbrol-maalin numero Nr farby Humbrol Νούμερο χρώματος Humbrol</p>

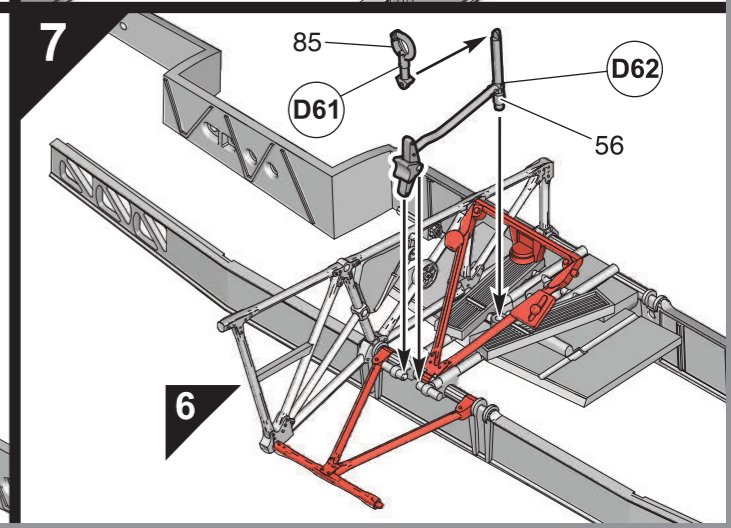
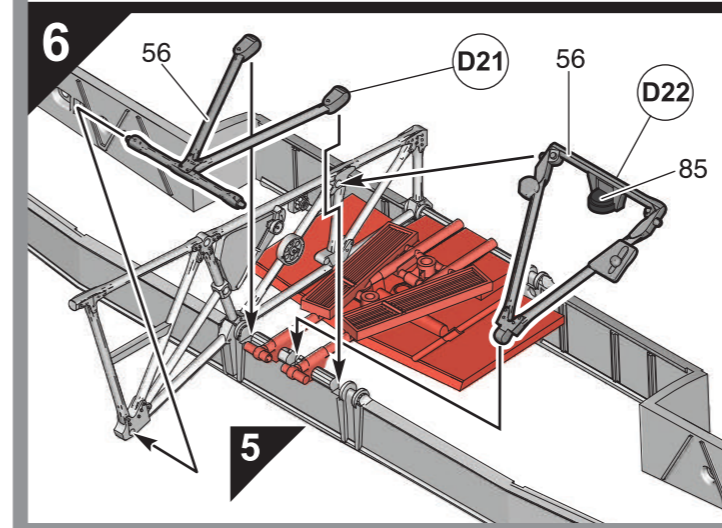
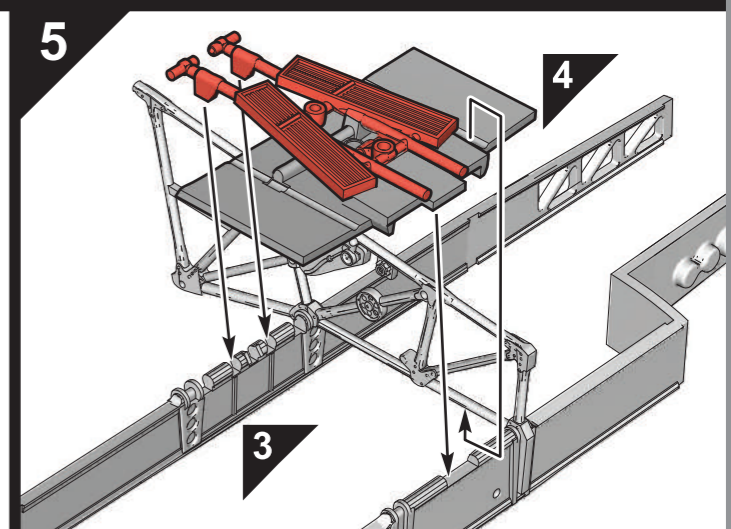
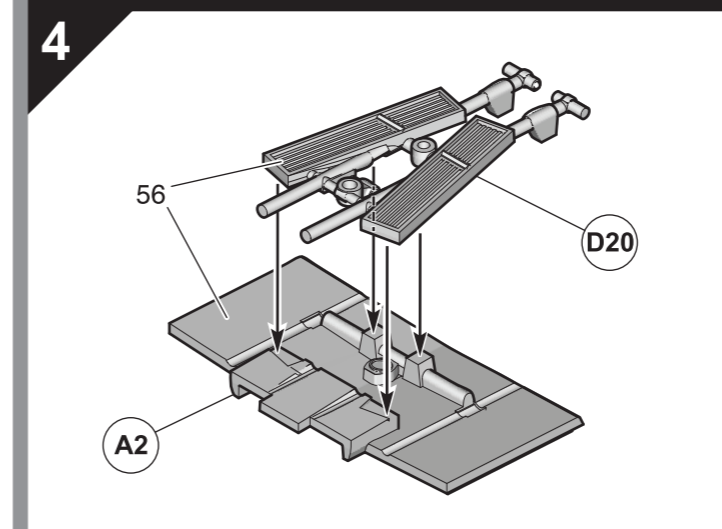
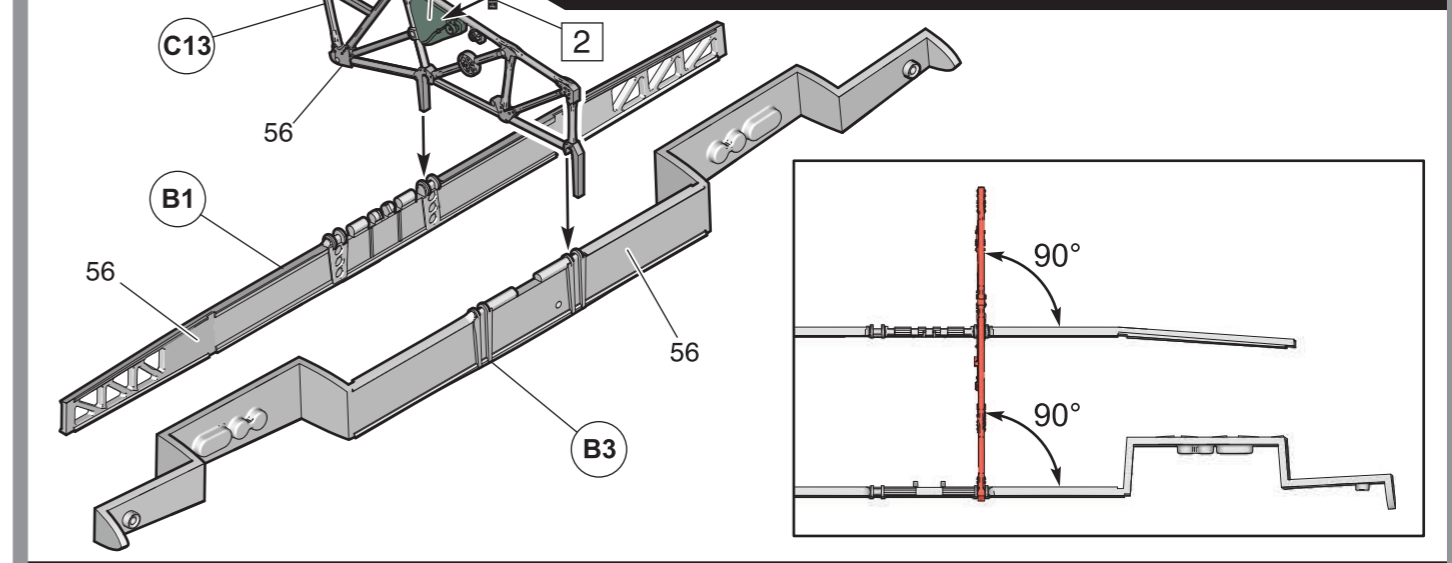
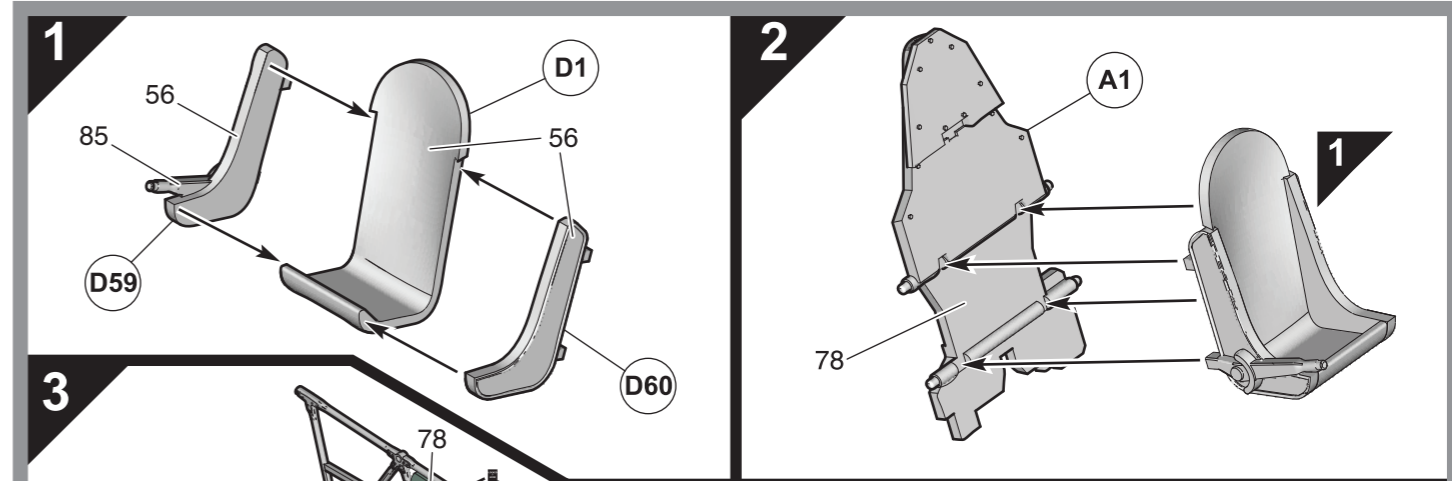
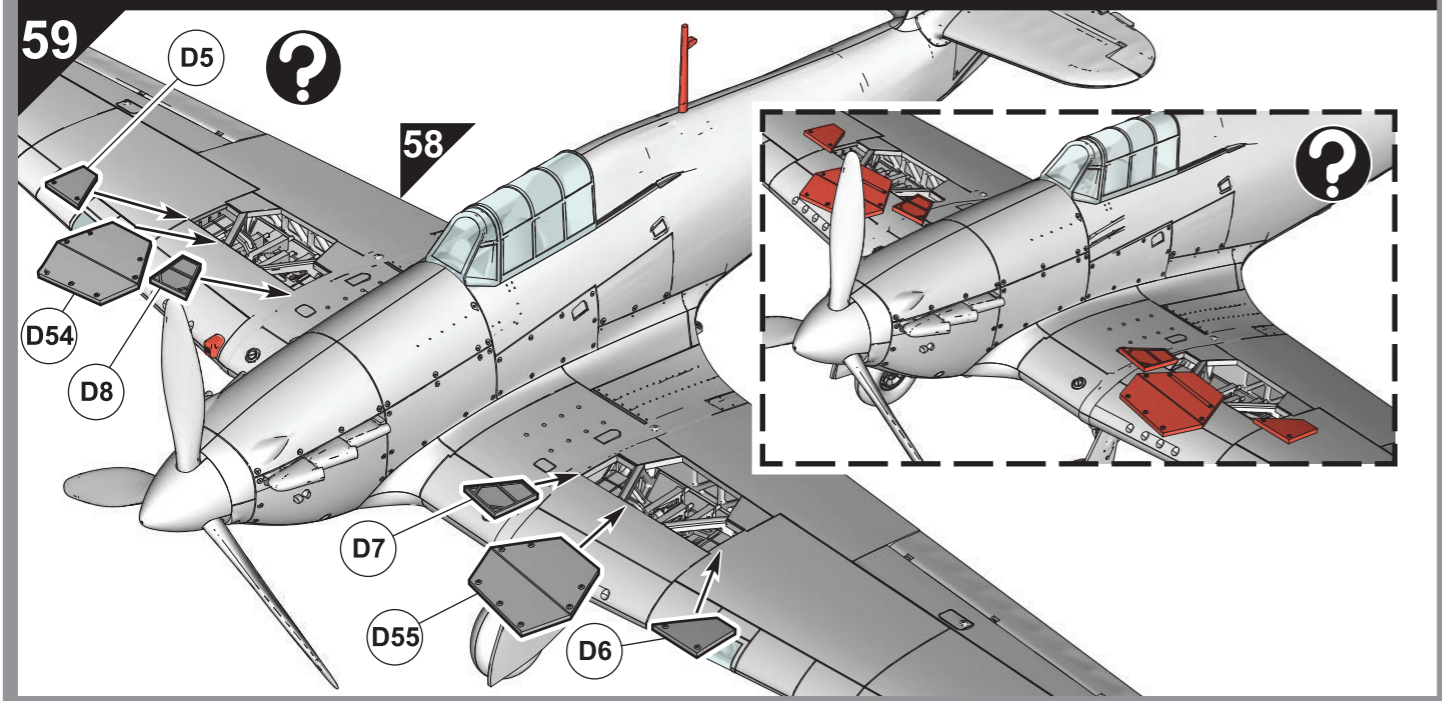
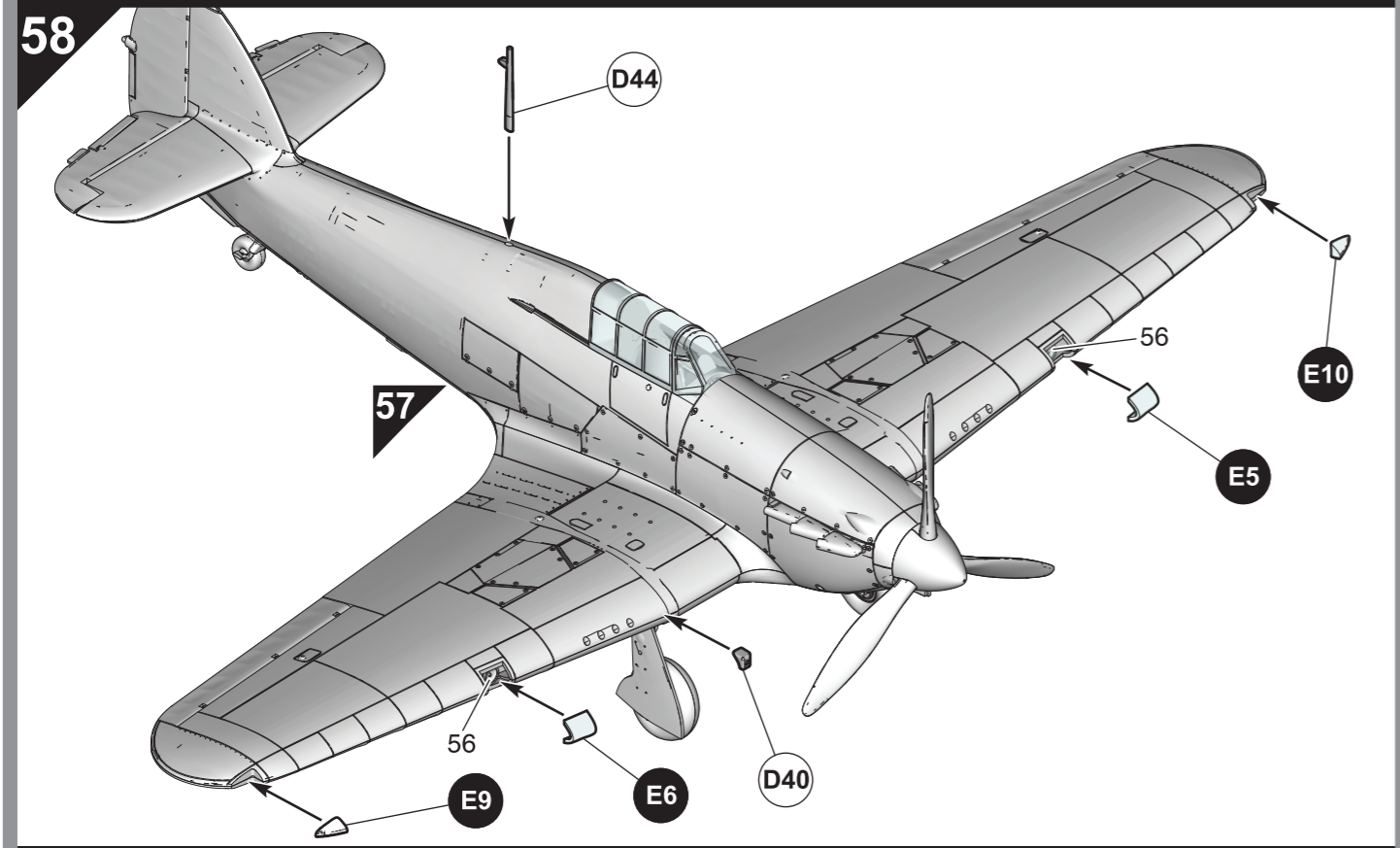
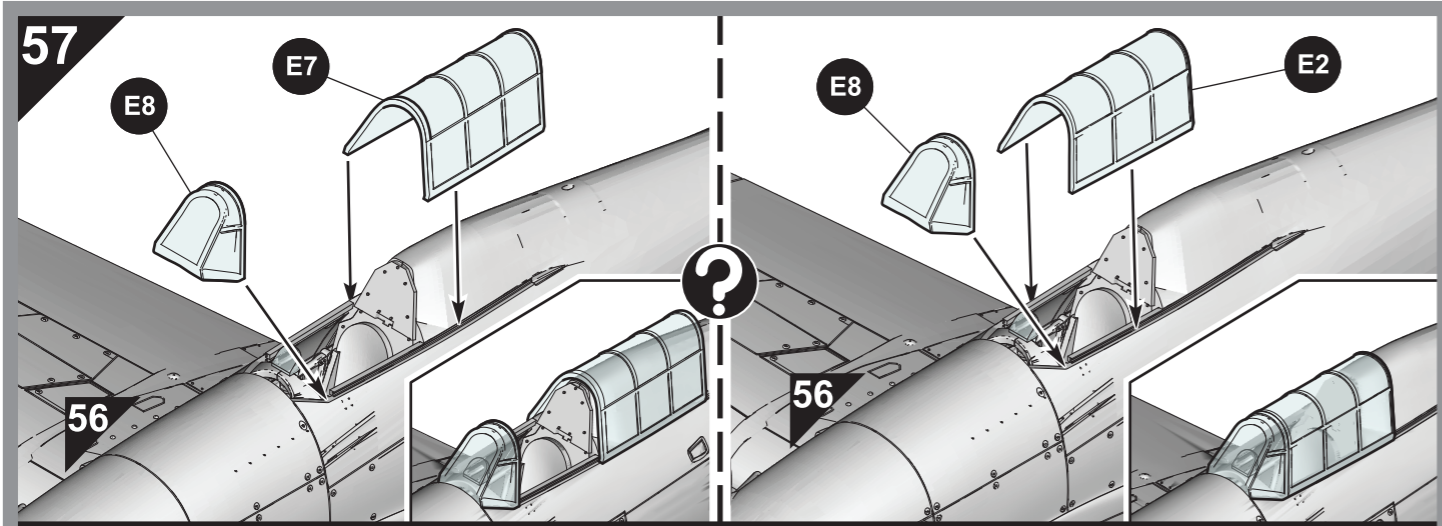

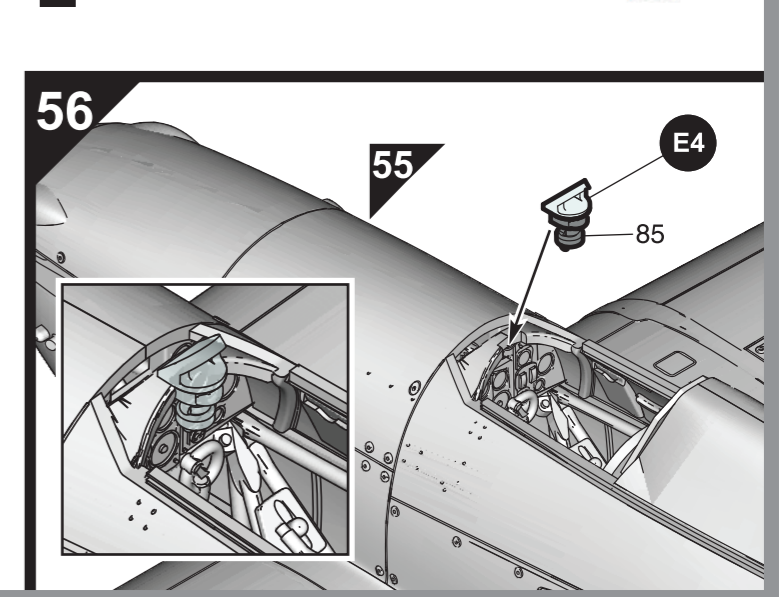
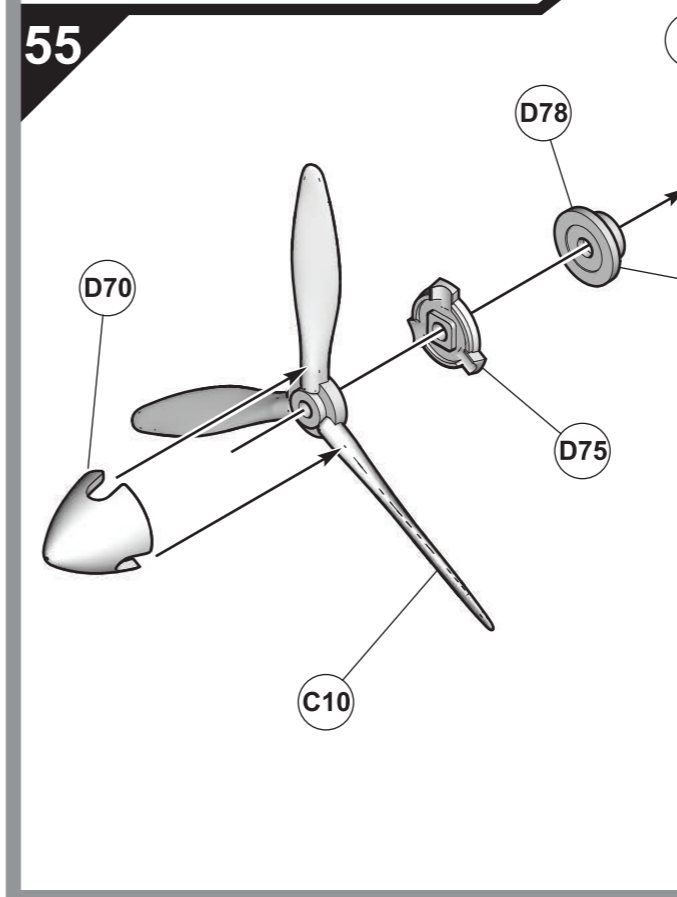
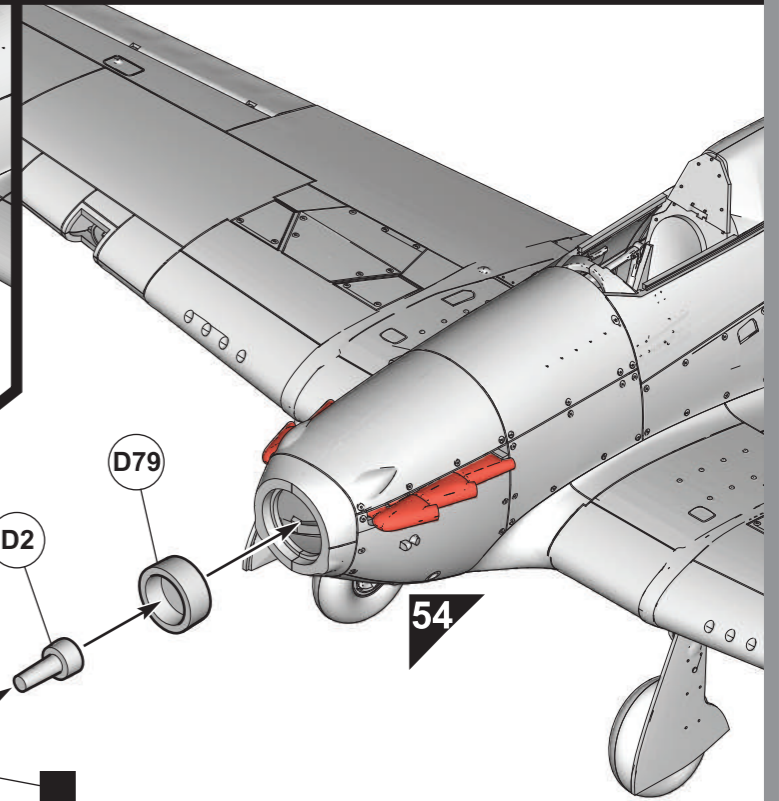
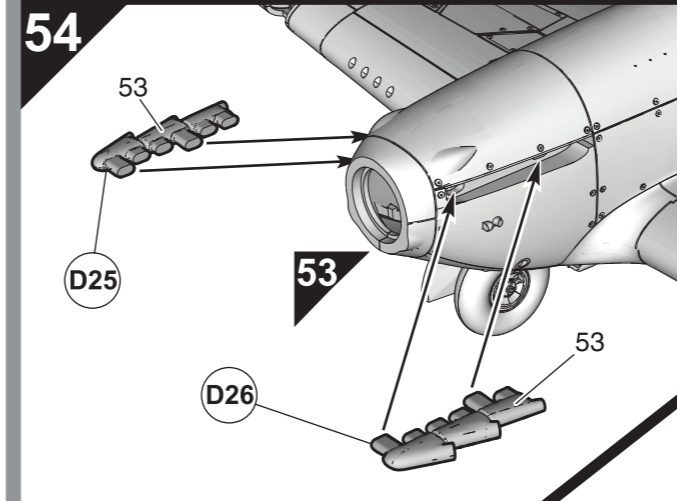
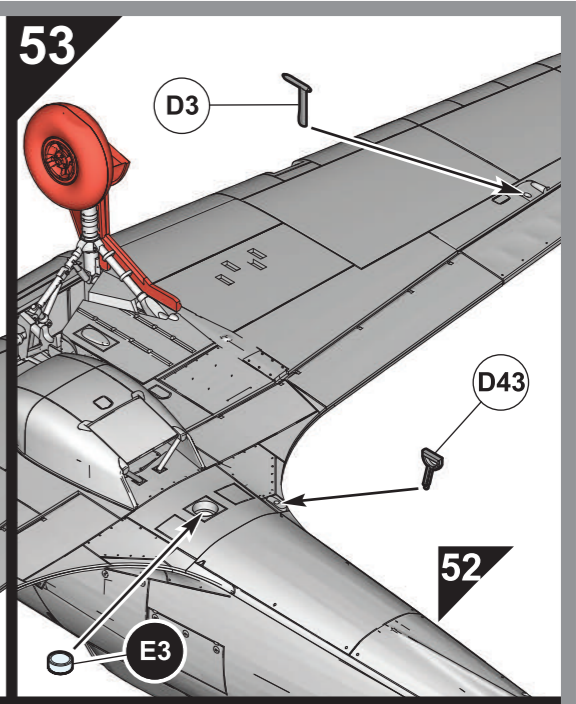
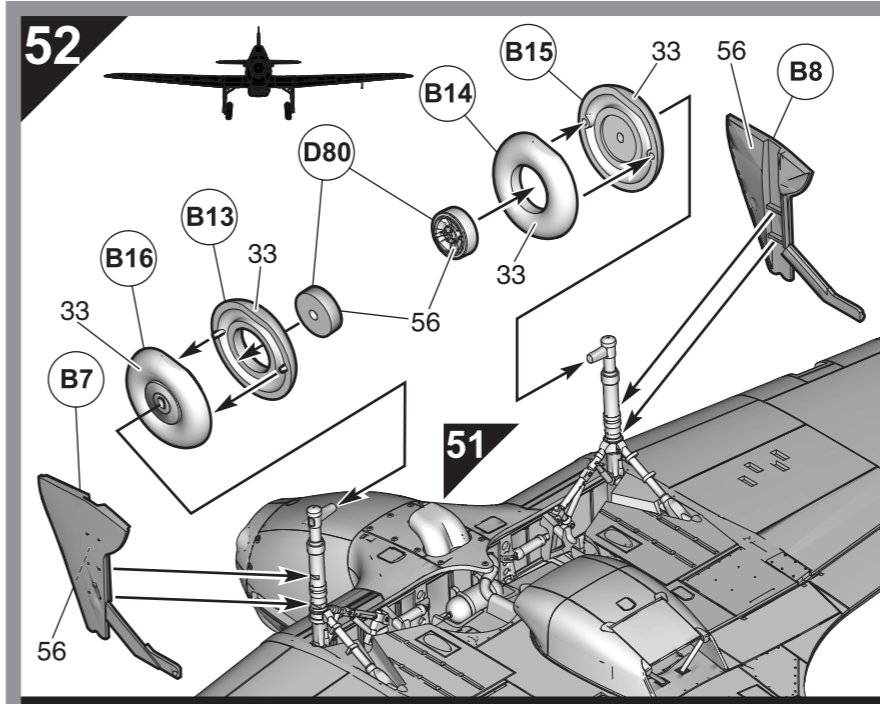
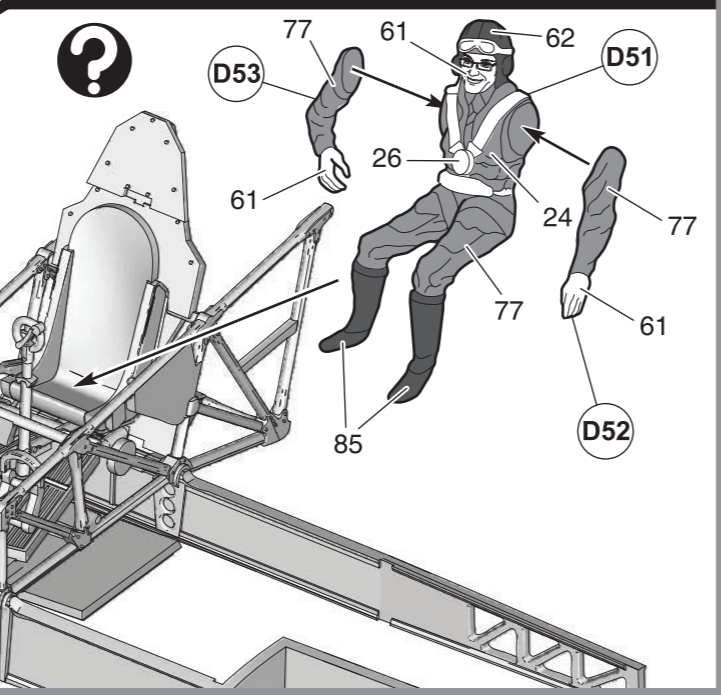
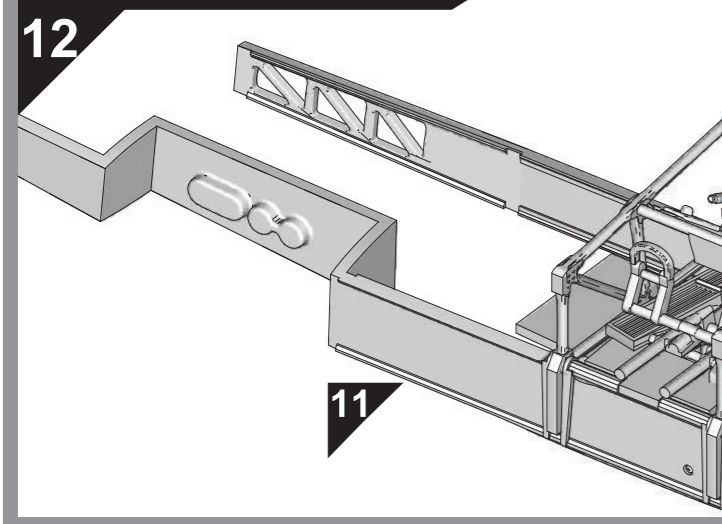
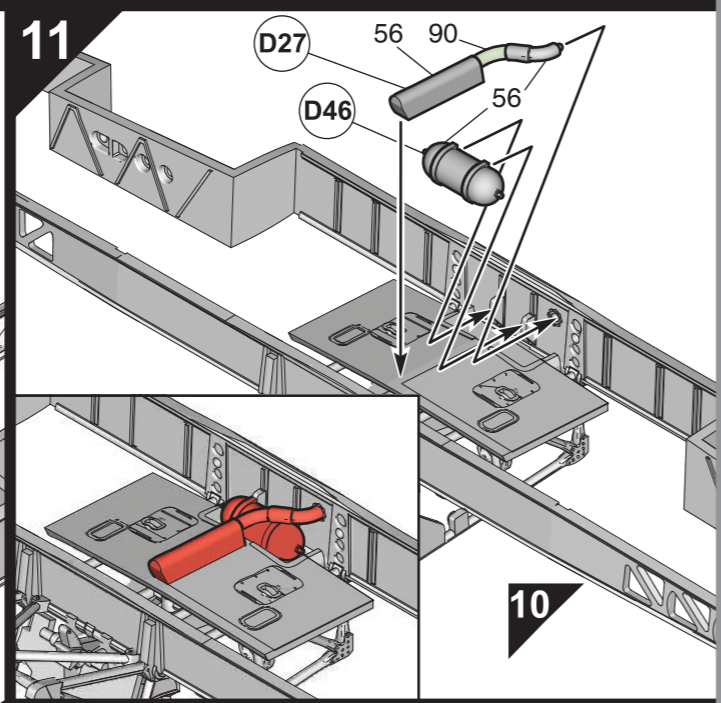
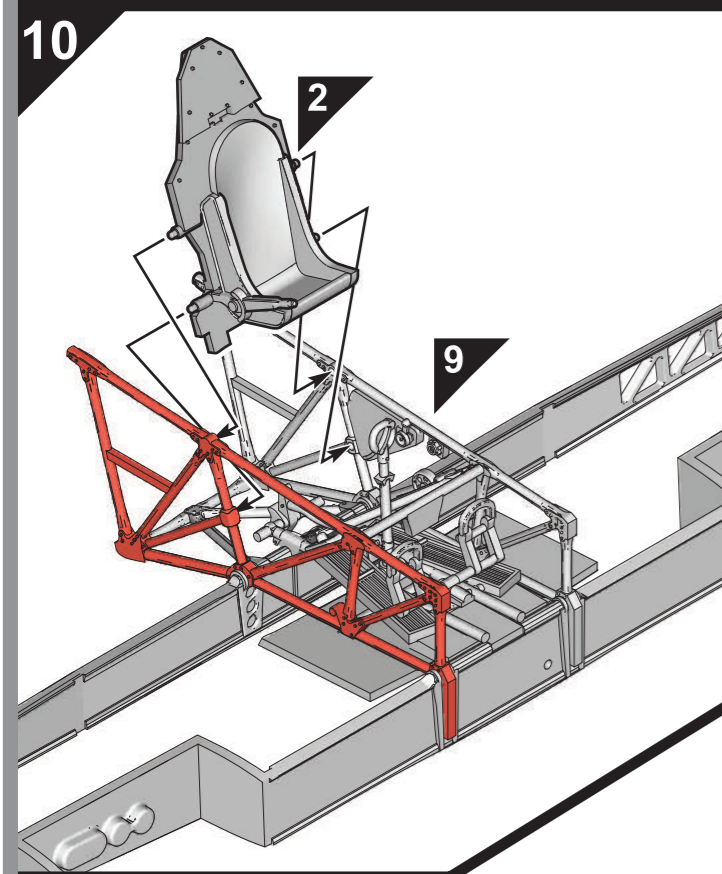
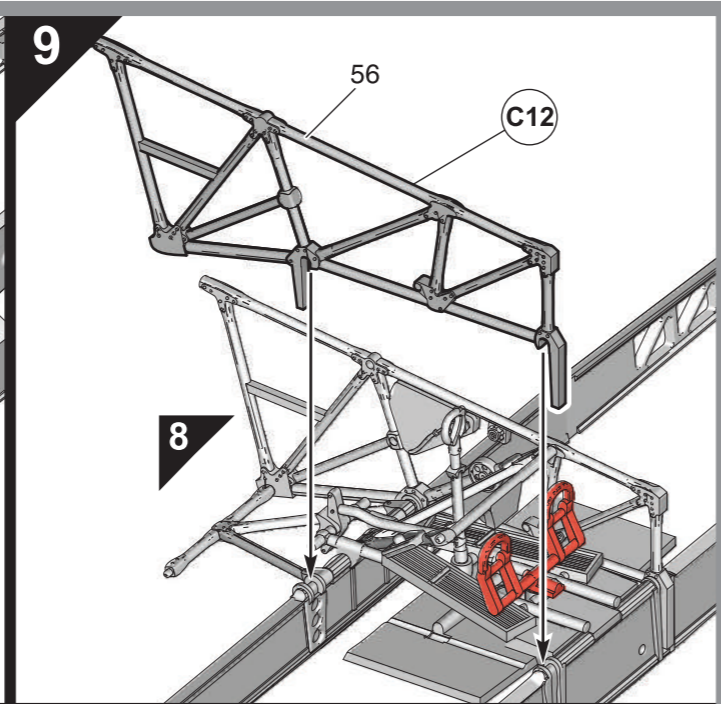
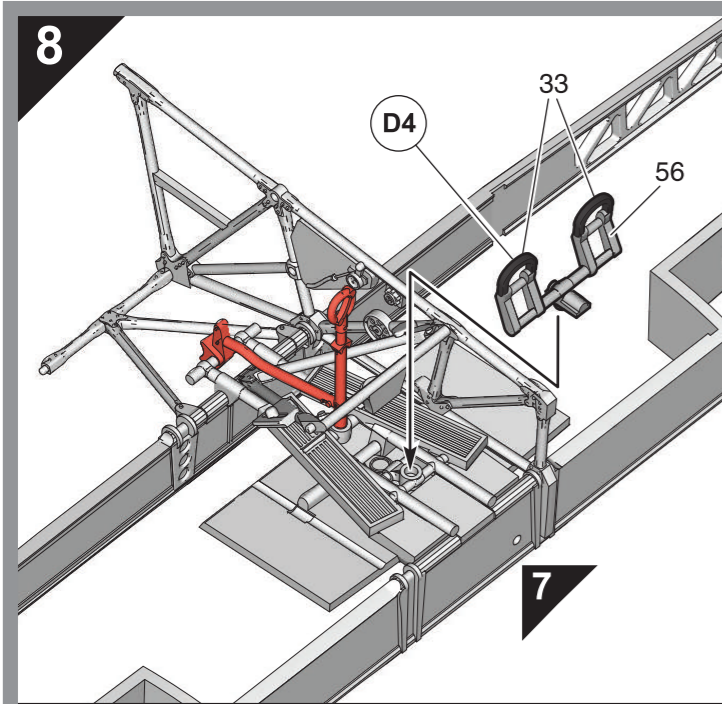

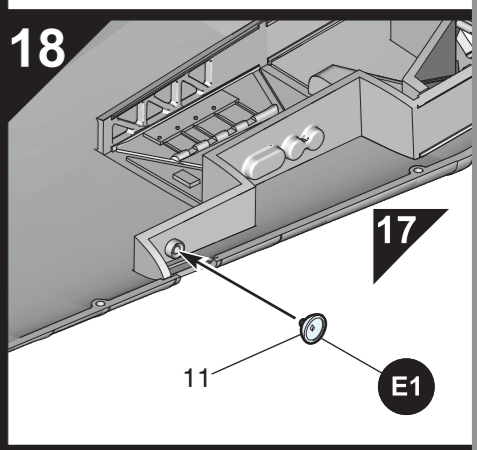
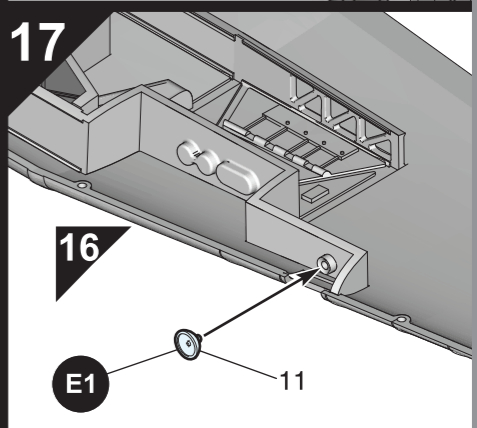
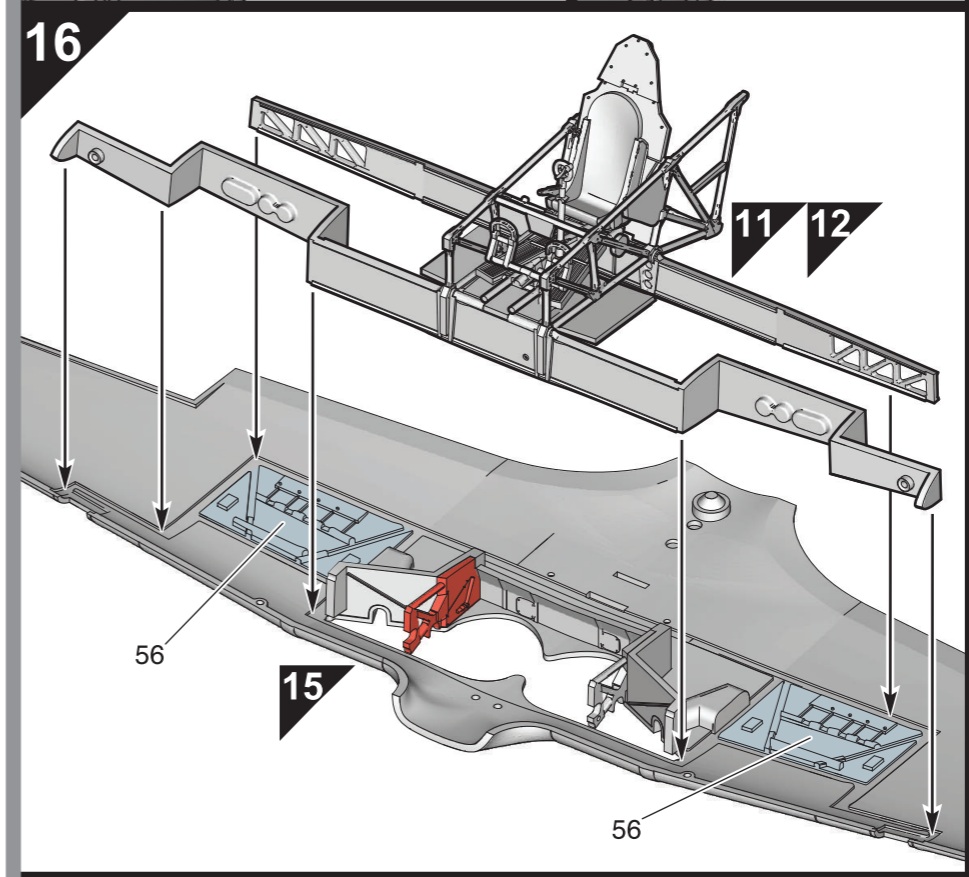
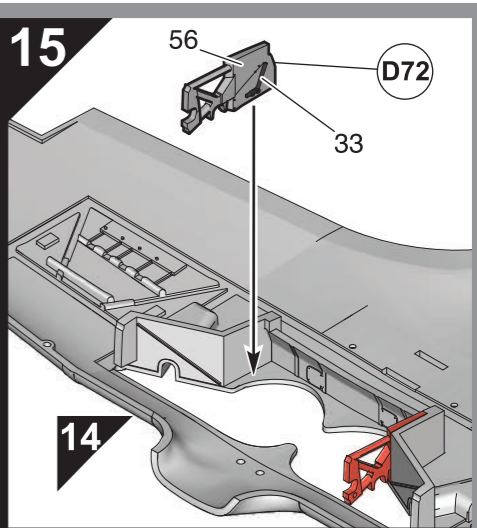
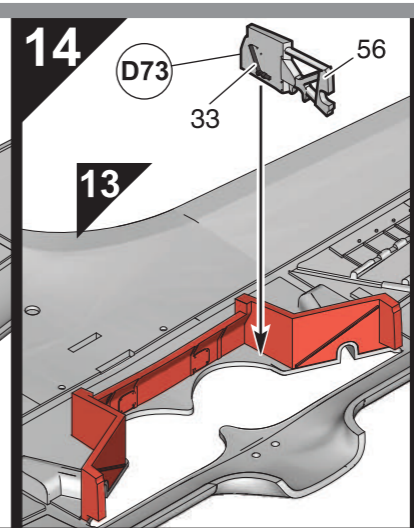
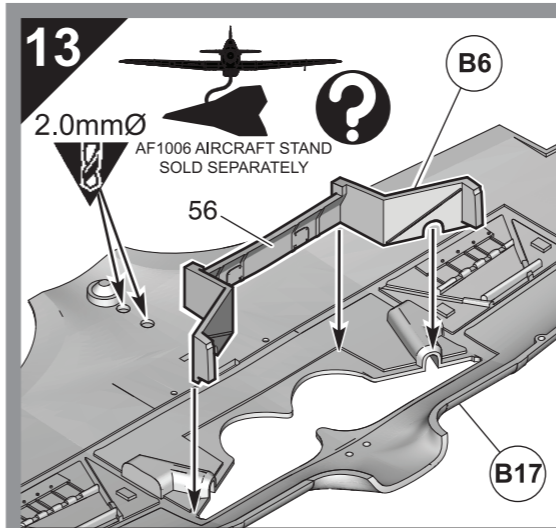
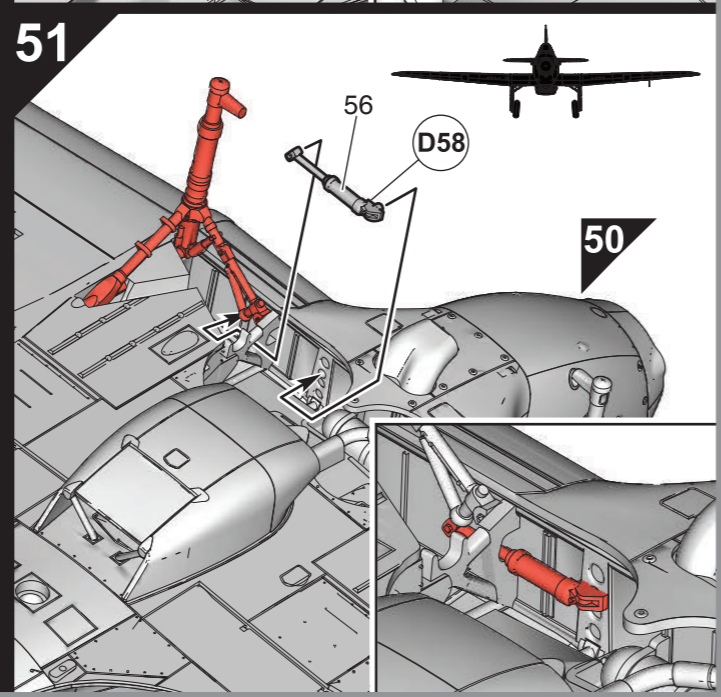
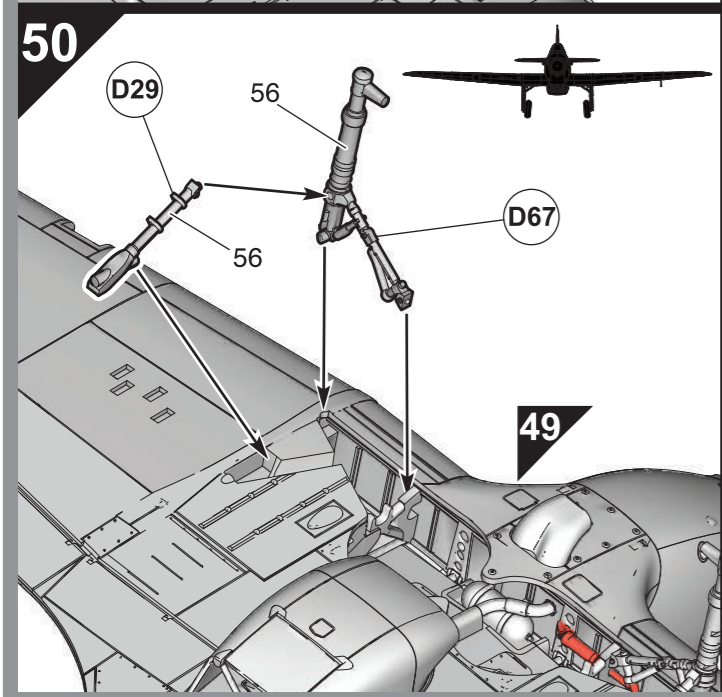
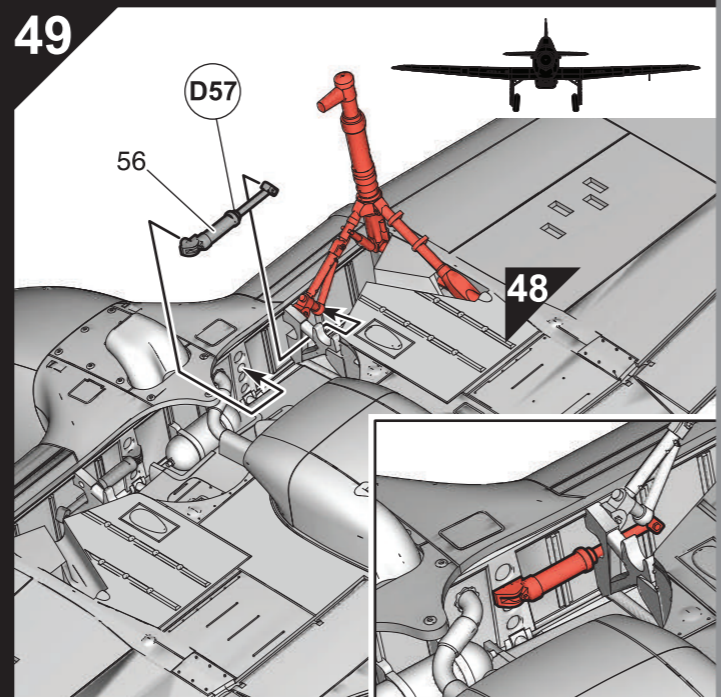
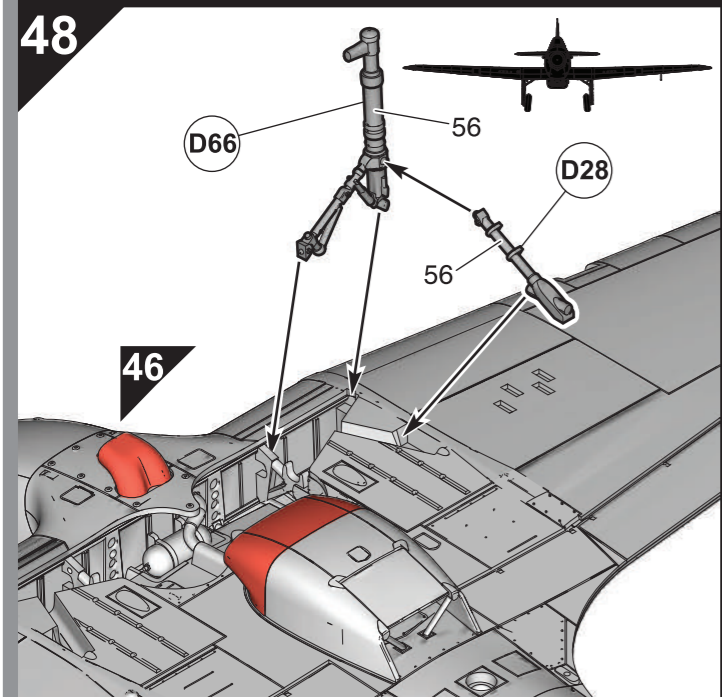
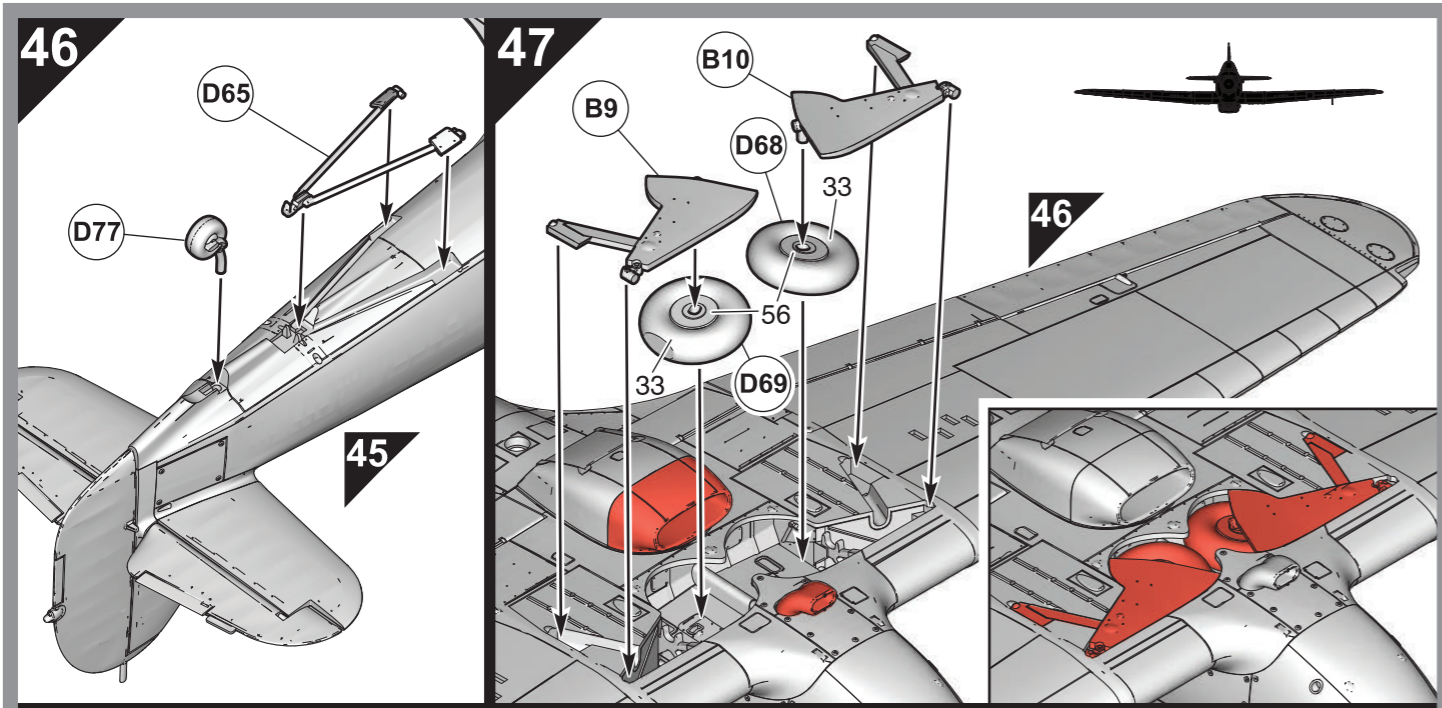

**19** **?** **Option 1:** For open gun bays, cut out the access panels shown here and fit the gun breeches shown in Steps 20 to 29.

**Option 2:** To leave the gun bays covered do not cut out the access panels and miss out Steps 20 to 29.

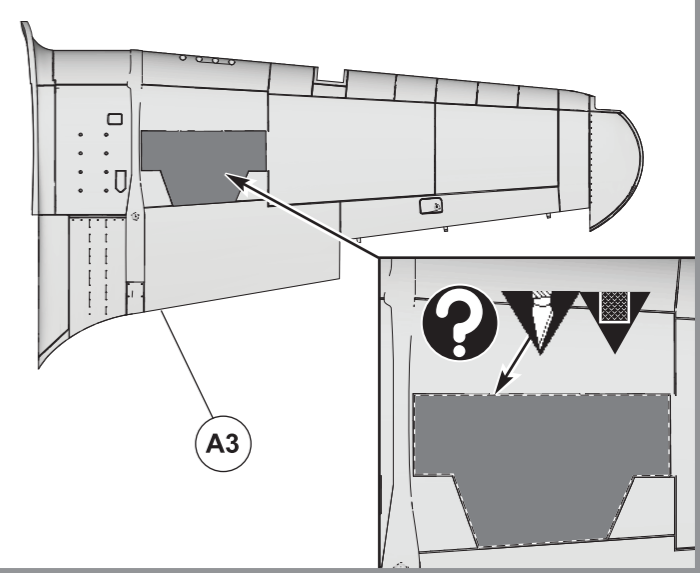
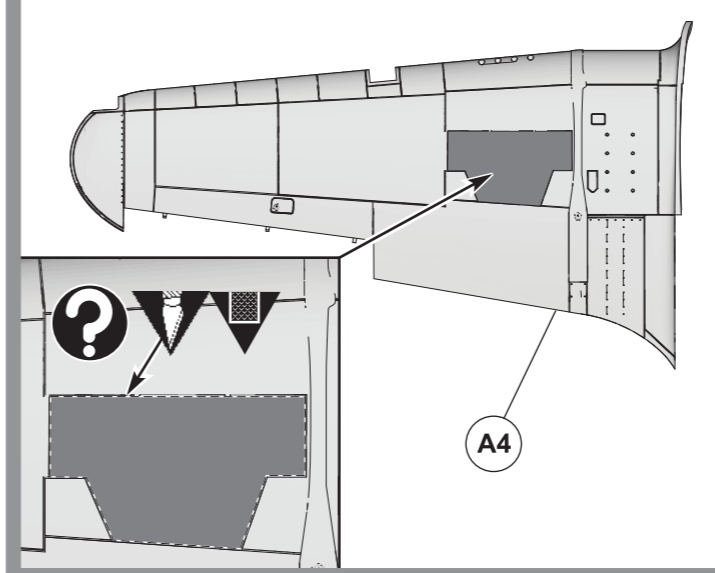

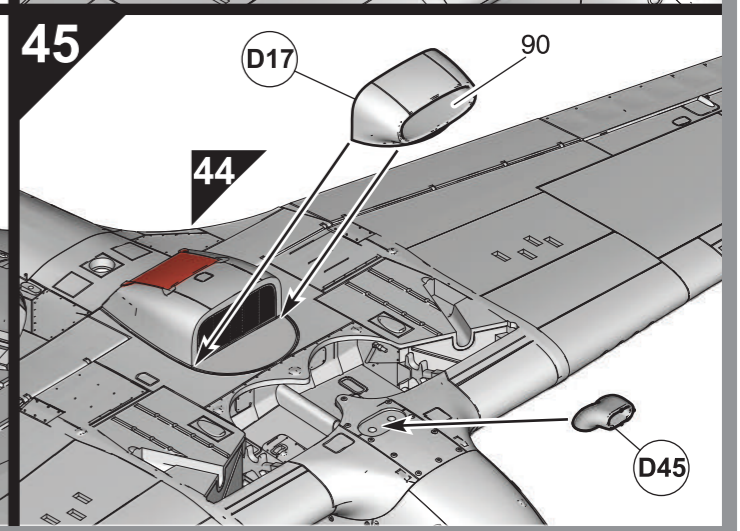
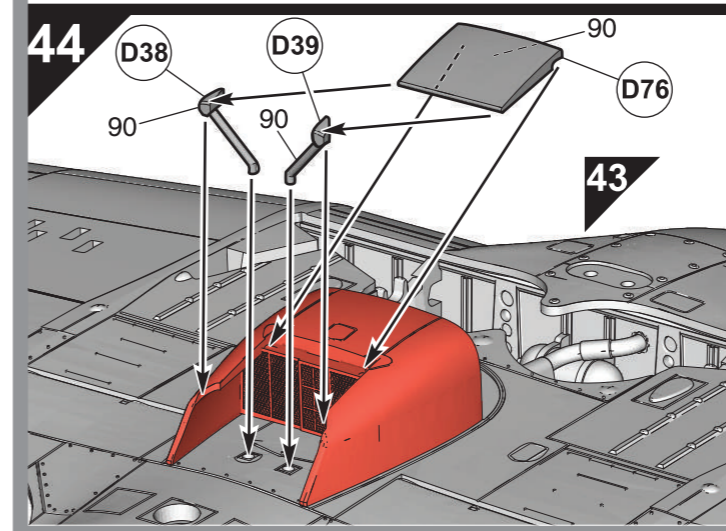
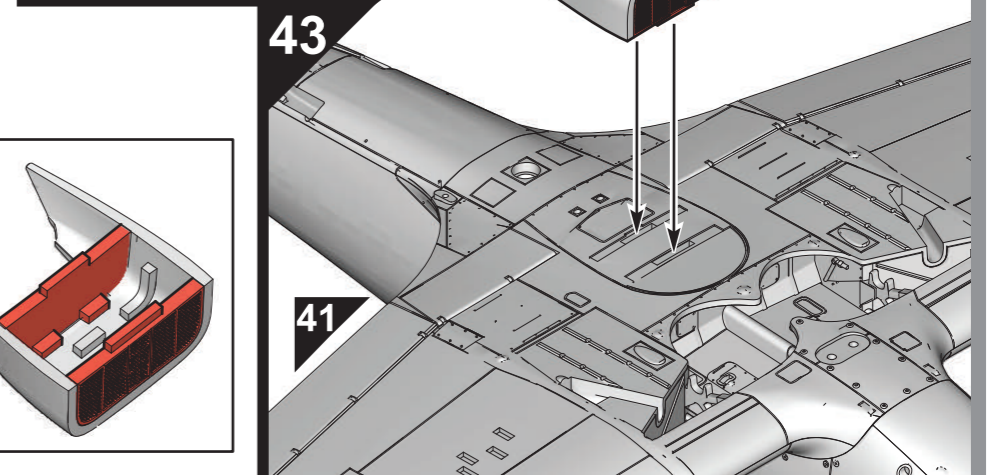
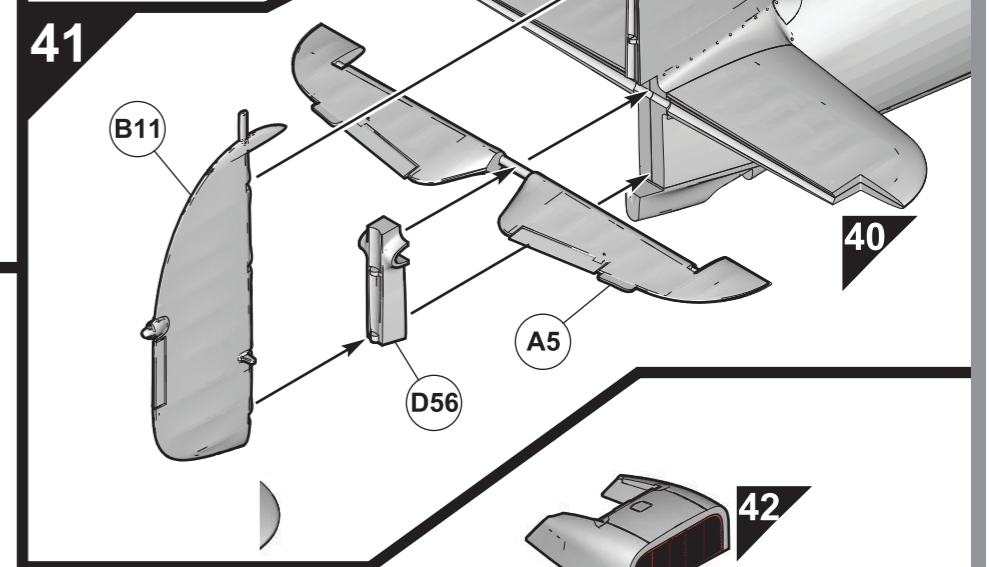
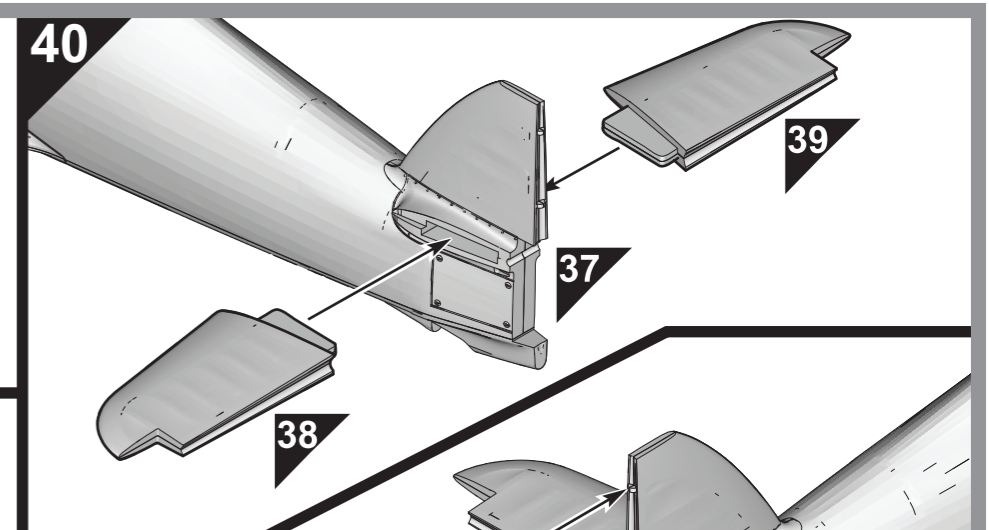
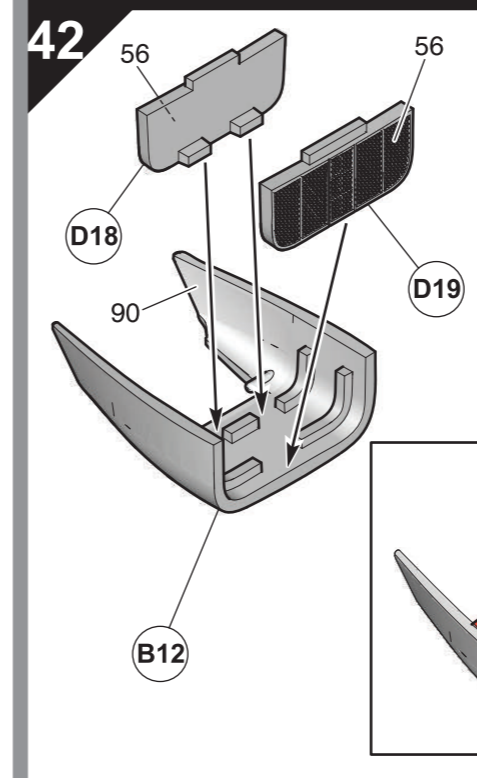
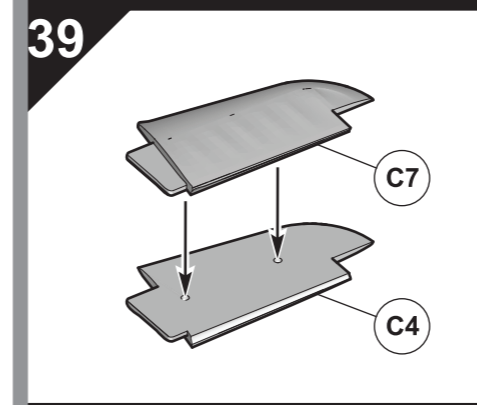
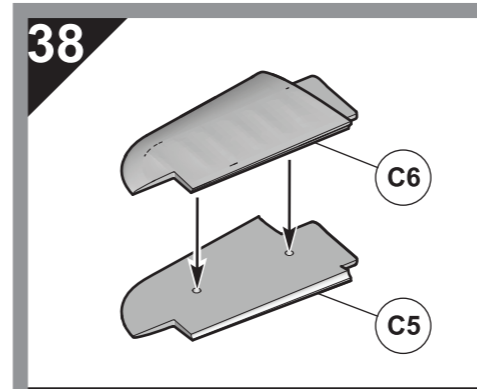
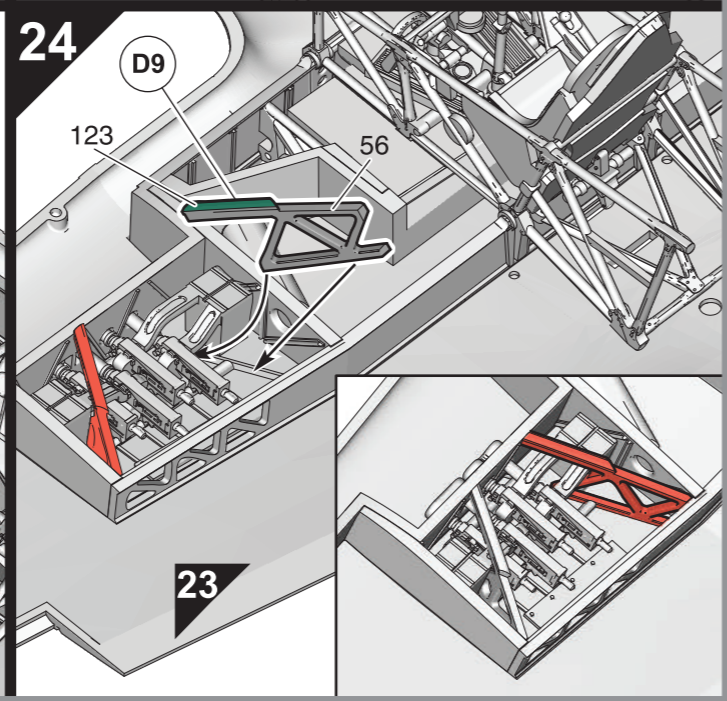
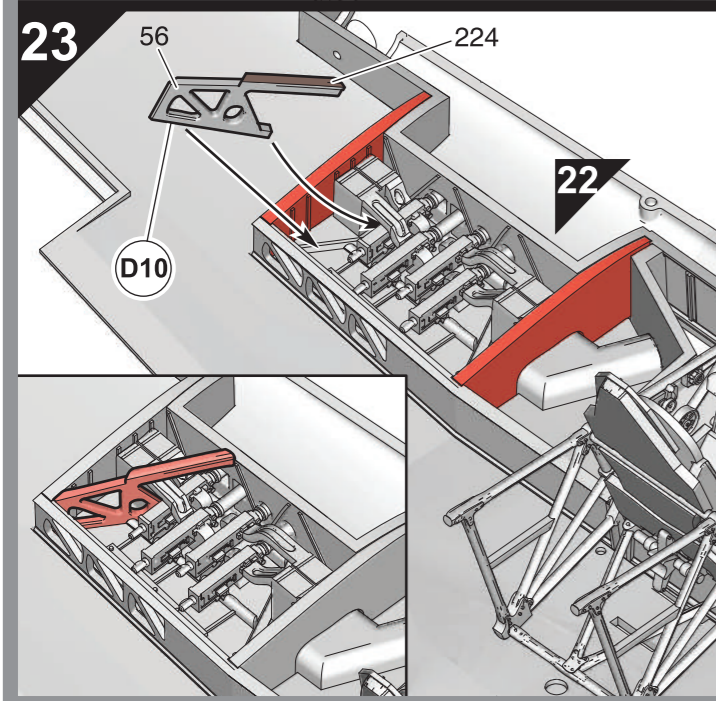
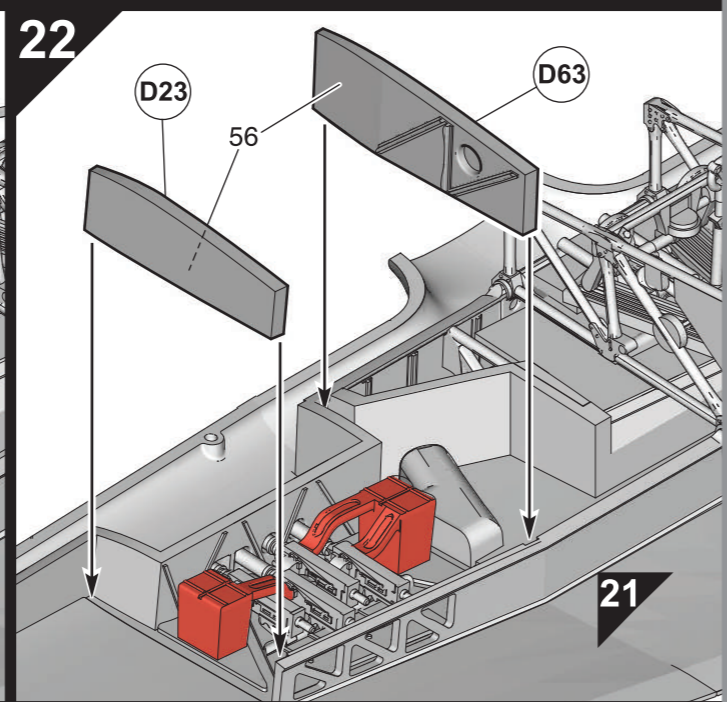
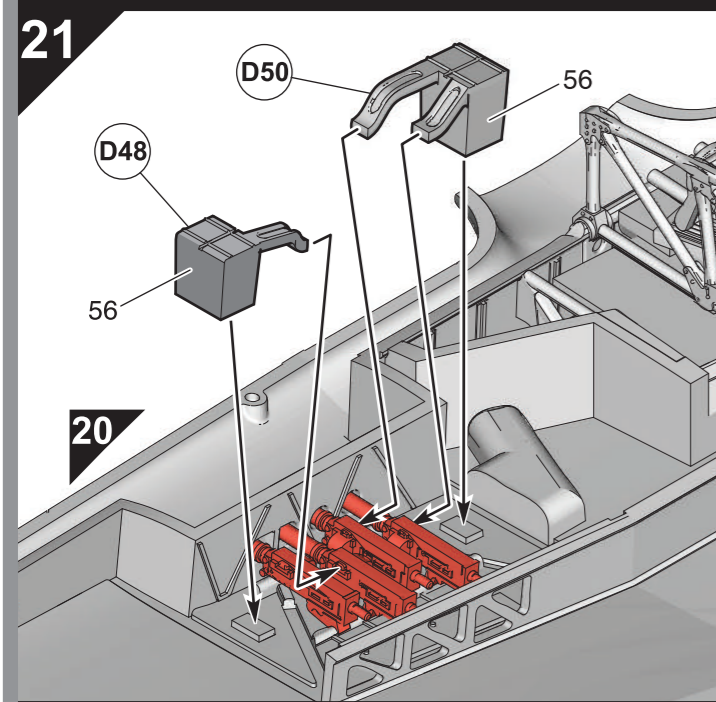
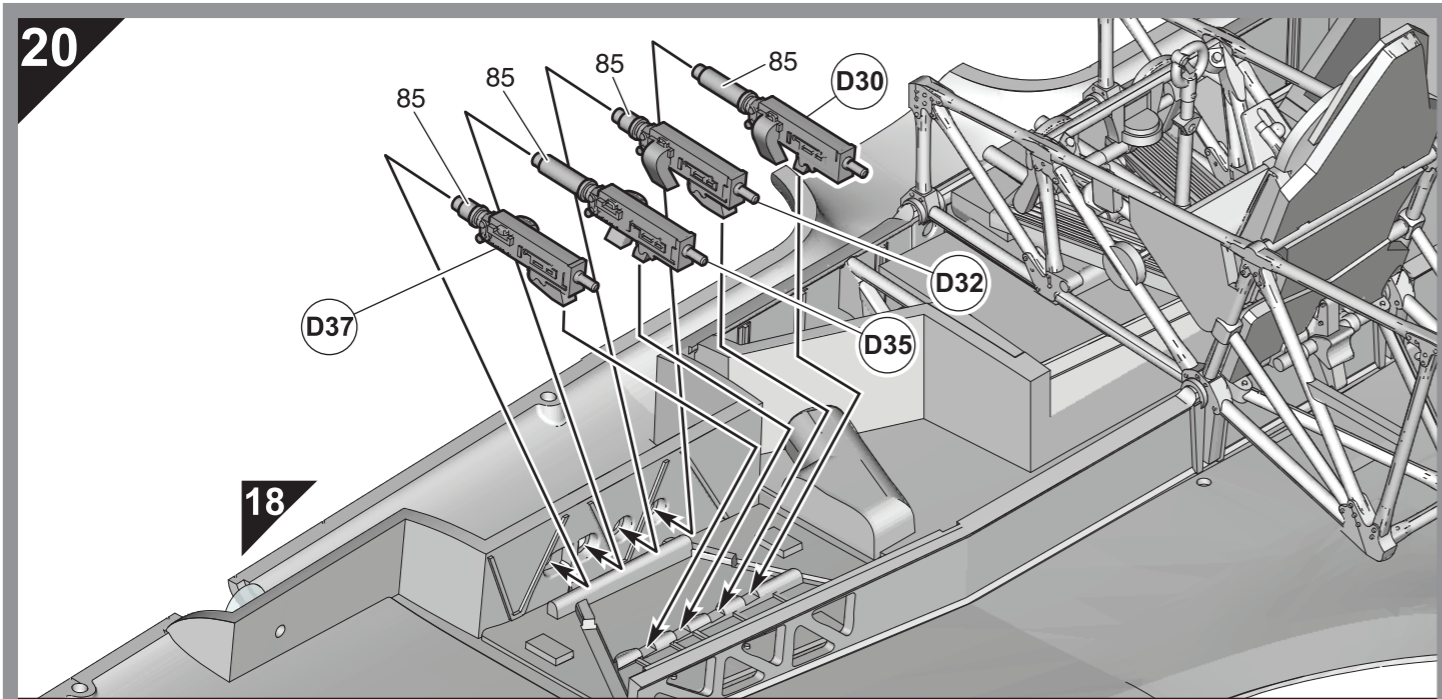

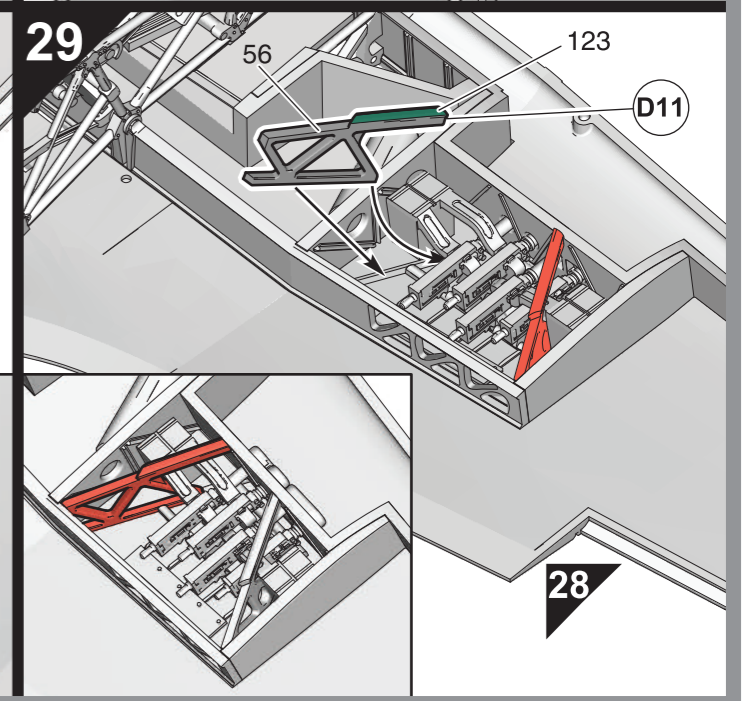
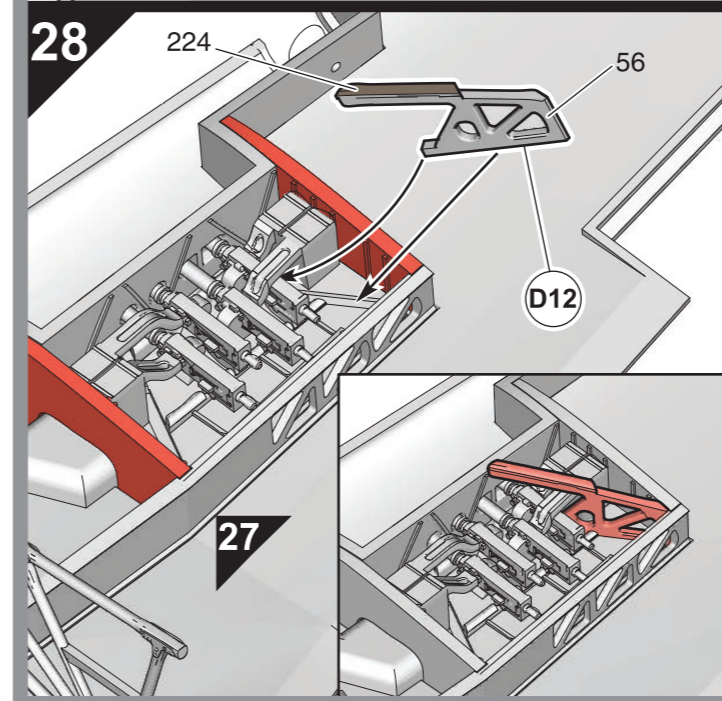
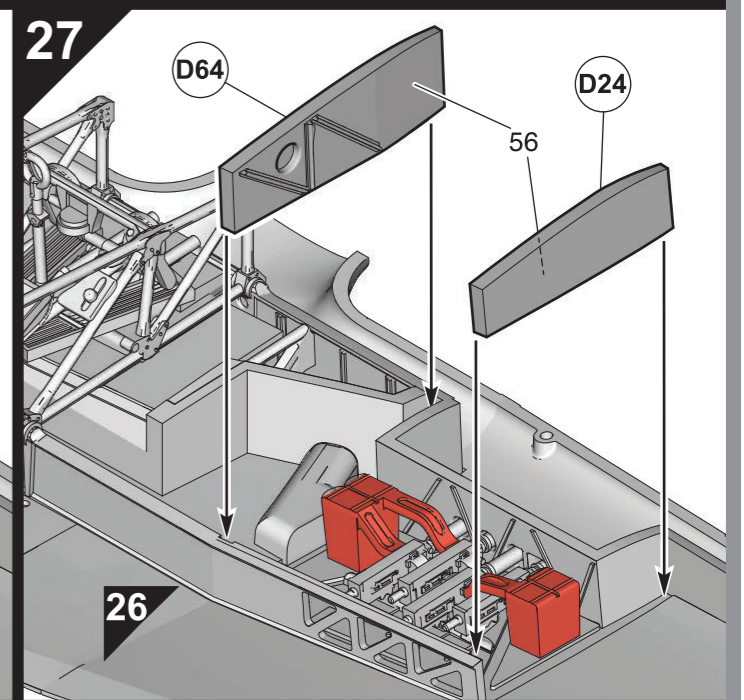
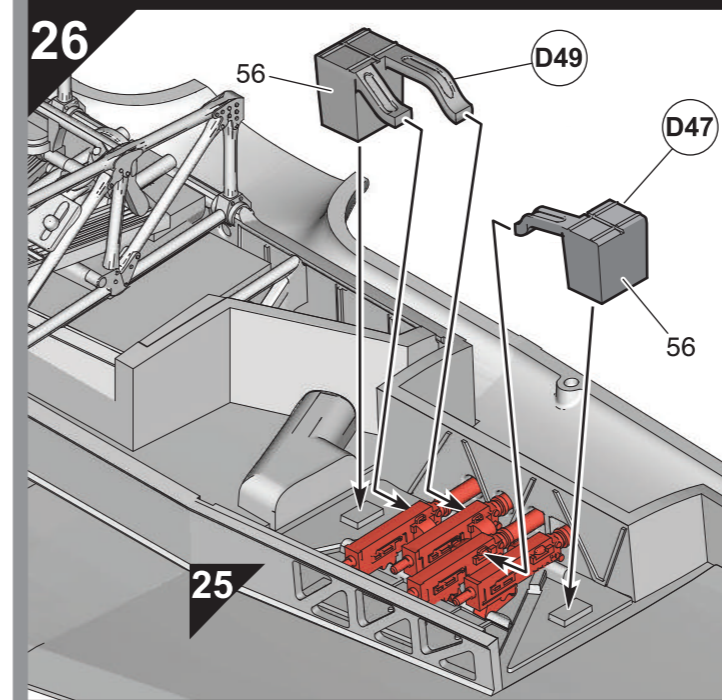
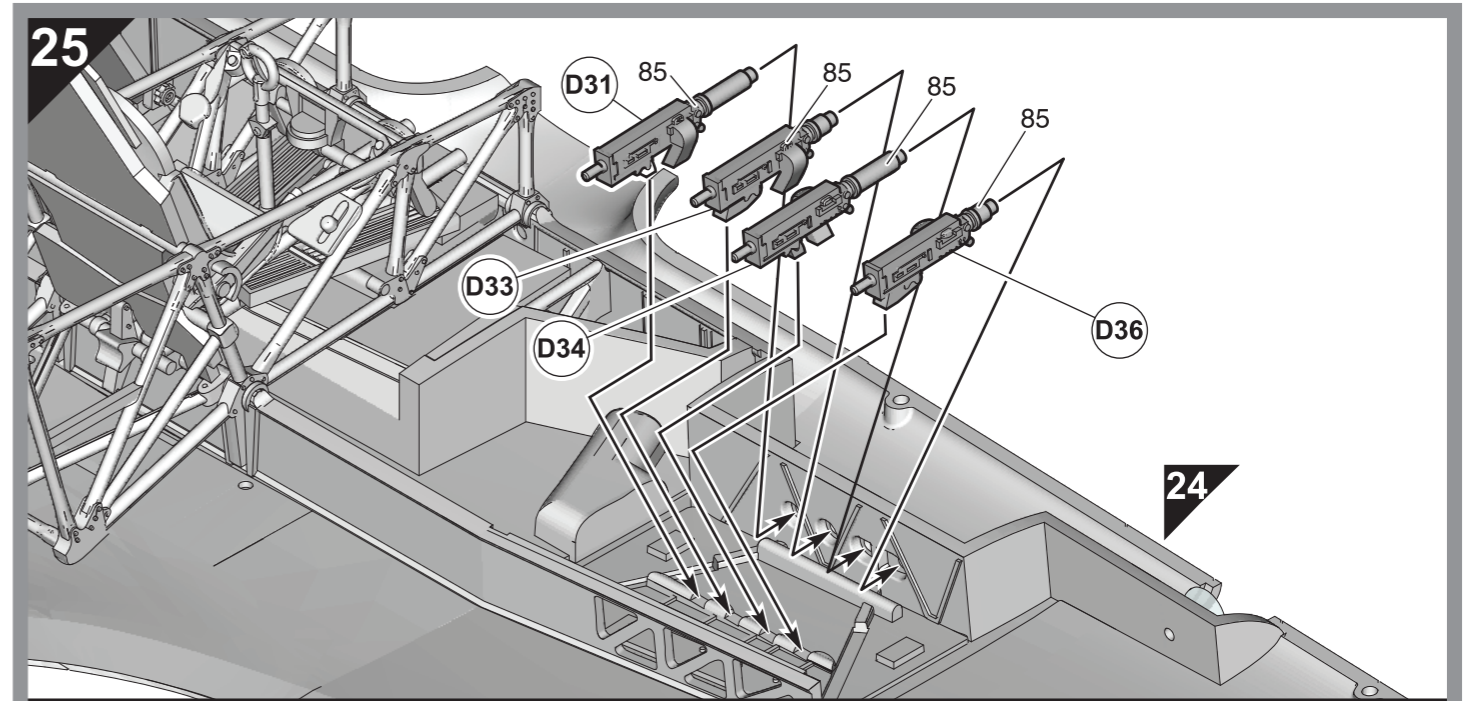
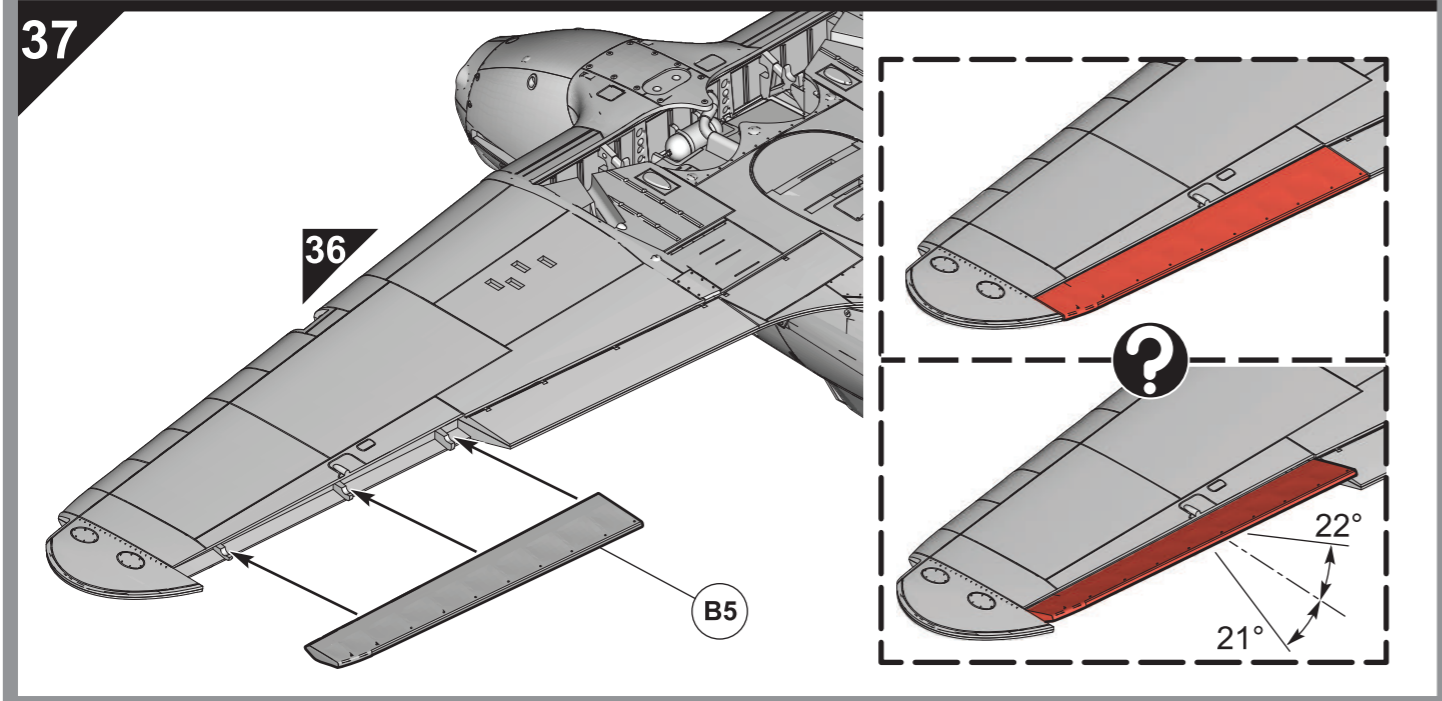
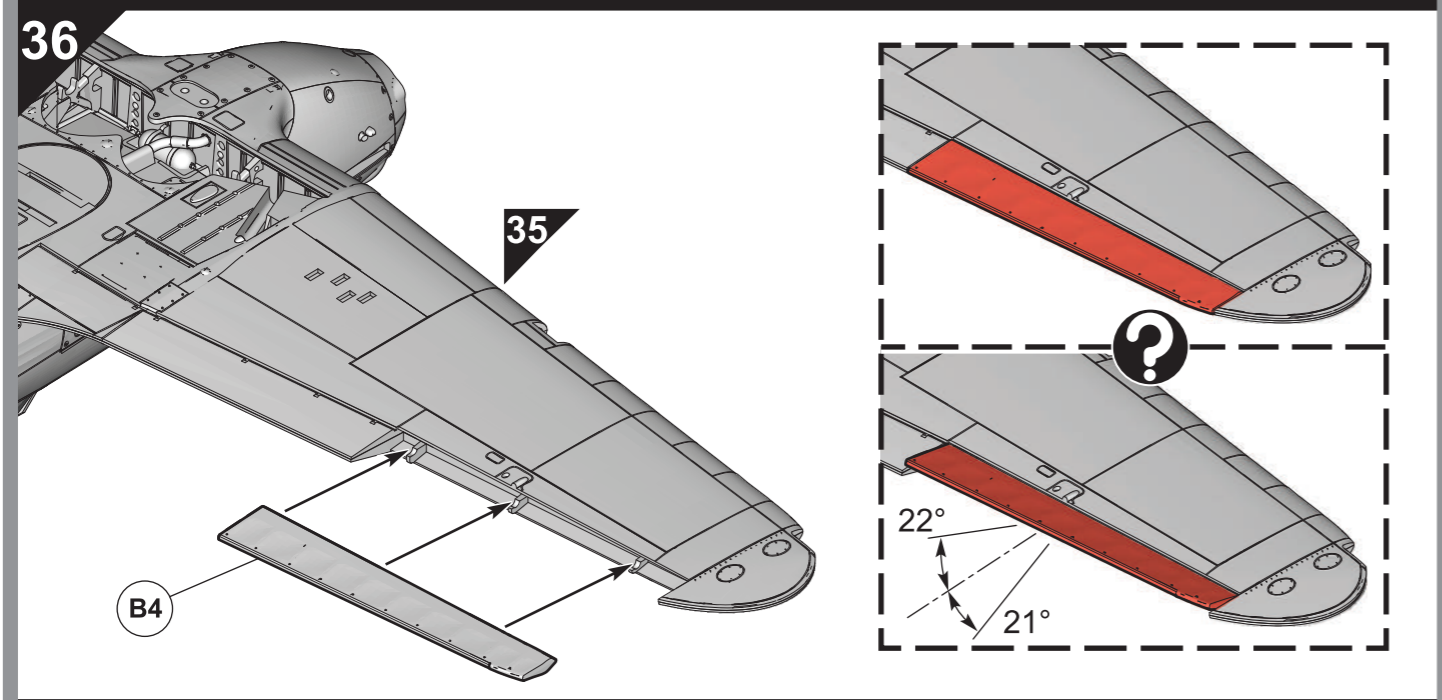
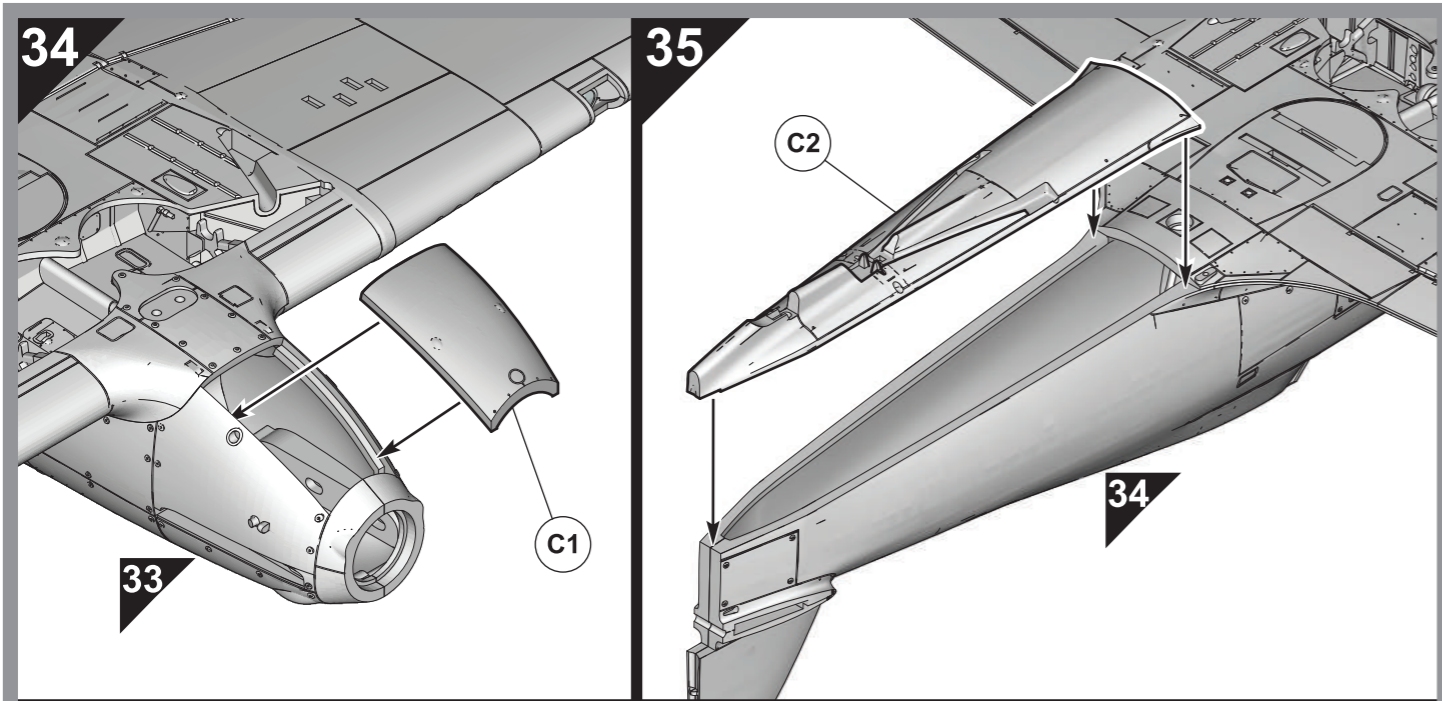

30

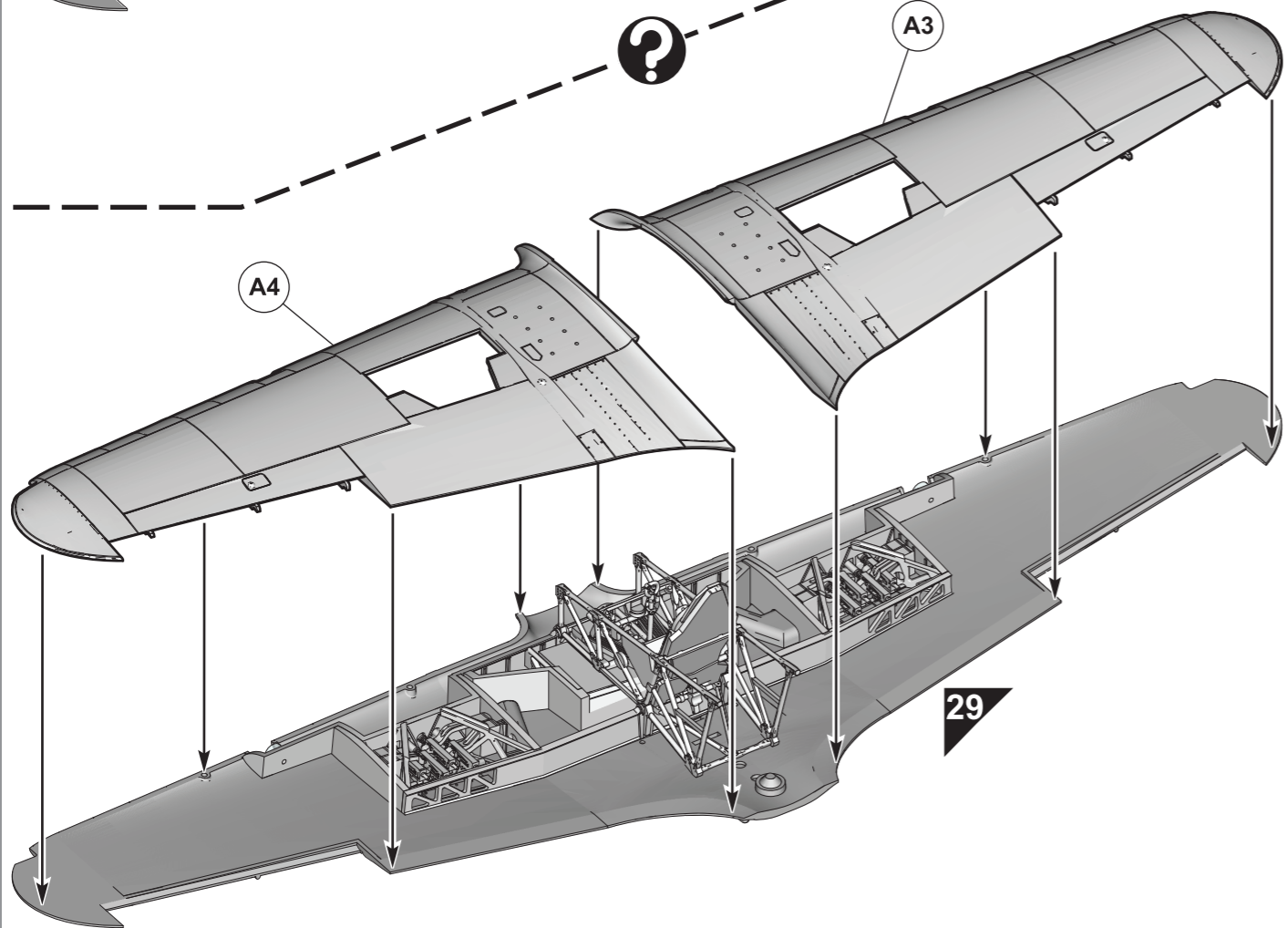
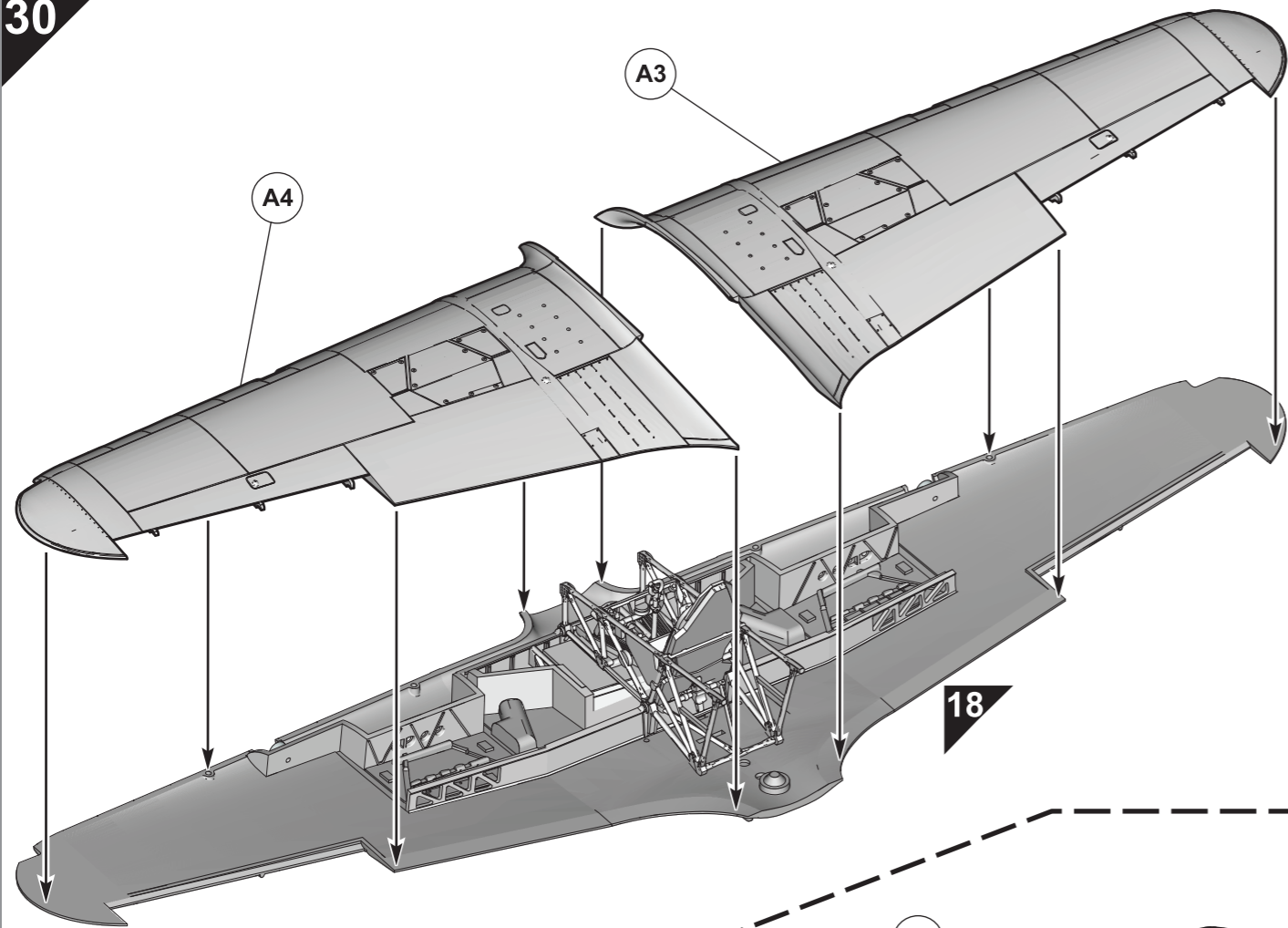

31

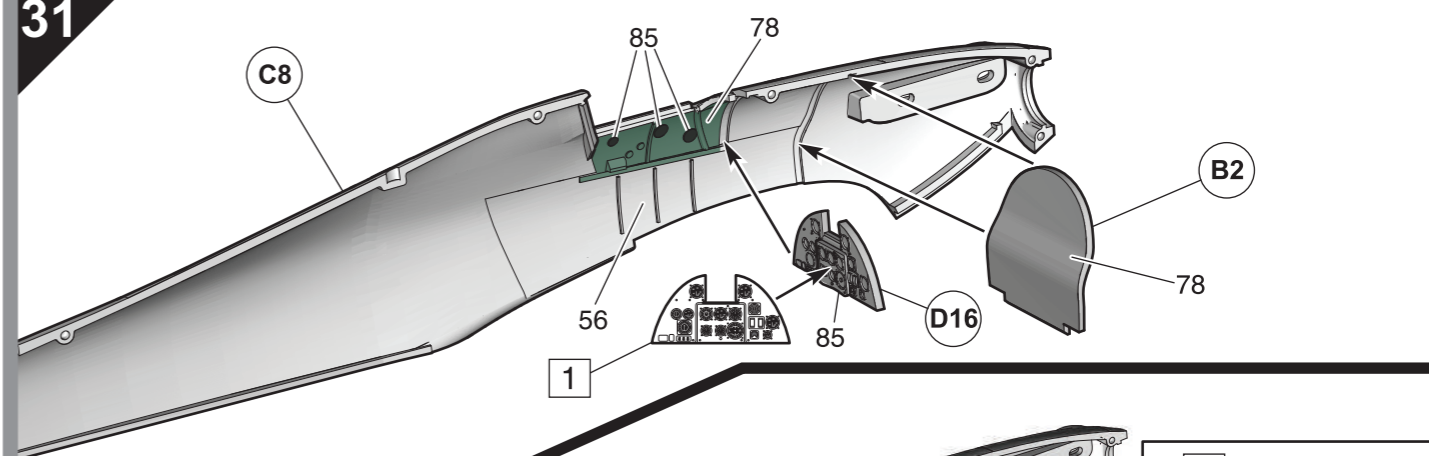

32

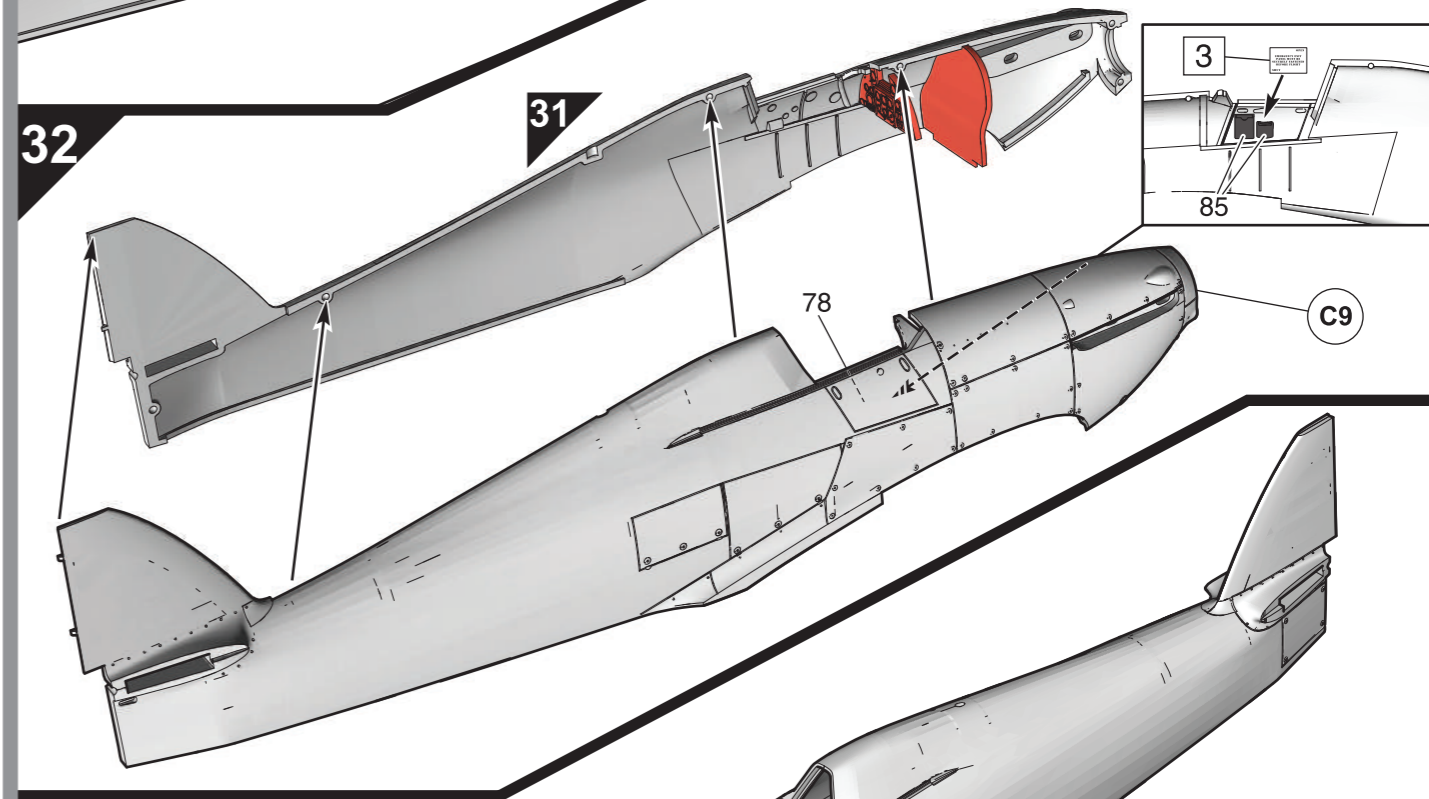

33

