

Fw 190A-4 „engine flaps & two wing guns“

eduard

1/48 Scale Plastic Model Kit



item # 84117

WEEKEND
edition

The Focke-Wulf Fw 190 was the best what was available to the Luftwaffe during the second half of the World War II. It soldiered in various versions and modifications as the aircraft for many different tasks.

The dedicated fighter version of Fw 190 was a high performance, heavily armed aircraft. To meet the 1938 specification issued by the Technisches Amt, RLM, the development team led by Kurt Tank ran into several difficulties, which were addressed continually during the process of the development. The first prototype took to the air on June 1, 1939 and after a series of improvements and, also after some quite radical changes, the design culminated during the fall of 1940, when twenty-eight units of pre-series Fw 190A-0 variant were built. Six of these were retained by the test unit Erprobungsstaffel 190 at Rechlin, tasked with service trials. These revealed a wide range of flaws to the point where the RLM halted further development. Nevertheless, as the test unit staff recommended, the design team was given another opportunity. After series of some fifty modifications, the RLM gave the go ahead for the Fw 190 to be taken into inventory of the Luftwaffe.

Into combat

During June 1941, the Luftwaffe accepted the first of 100 ordered Fw 190A-1s, armed with four 7.9 mm MG 17 machine guns. The II./JG 26 was completely equipped with the type and operating on the Western Front by September 1941 and its operations changed the game, as the new fighter was superior not only to the Hurricanes, but also to the Spitfires. The very first Fw 190 lost in combat was the Fw 190A-1 (factory No. 0028) flown by Gruppenkommandeur (Group Commander) of II./JG26 Walter Adolph. He was shot down on September 18, 1941.

During November of the same year the production of the next version Fw 190A-2 commenced. The new variant was powered by a BMW 801C-2 engine and armed with two 7.9 mm MG 17s and two MG 151s of 20 mm caliber in the wings. Part of this series received an additional pair of 20 mm MG FFs, thus attaining an armament standard of later types. A significant advancement to the design came in the spring of 1942, when the BMW 801D-2 engine became available. Its installation allowed new Fw 190A-3 variant to be entered and in July 1942 the development continued with the improved Fw 190A-4. Both were armed with what became the standard armament for future Fw 190s; i.e. two fuselage mounted MG 17s, two wing mounted MG 151 cannons, and two MG FF cannons, placed inboard of the wheel wells.

Mass production begins

During 1942 the production of Fw 190 had intensified, and another production facility was set up at Fieseler, where the "Würgers", as the Fw 190s were nicknamed, were built under license. Thanks to this step and to other measures, production rose in 1942 to 1,878 units, comparing quite amazingly to just 224 aircraft in 1941. Large-scale production of the Fw 190A-5 was initiated in April 1943 with an identical wing to the A-4 variant, but with a nose extension that would become standard on all subsequent Fw 190A versions up to the A-9, and on the corresponding F types. July saw the development of a new, strengthened wing, which incorporated MG 151s instead of the MG FFs in the outer position. The adoption of this wing developed into the Fw 190A-6 version. Further changes led to the Fw 190A-7, produced during the end of 1943. This version came about with the replacement of the fuselage mounted

MG 17s with 13 mm MG 131s. Further improvements led to Fw 190A-8, the variant, which became the most produced with some 6,655 units made. The most significant change was the installation of the GM-1 nitrous oxide injection system, used for temporary power boost in combat. A portion of A-8 production was dedicated to the A-8/R2 and A-8/R8 variants, armed with MK 108 cannon in the outer wing bays, and with armoured slabs fitted to the cockpit sides as well as to the canopy.

Last of the radial breed

The final production version of the BMW 801 engine powered fighter was the Fw 190A-9, equipped with the BMW 801TS of 2,000 hp (1,470 kW). There was a parallel development of these fighter-optimized aircraft with a dedicated fighter-bomber version, the Fw 190Fs. These aircraft had reduced wing armament to two MG 151 cannons in the wing root position. The engine was optimized for low level operation, and the armament options varied to satisfy the ground attack role, including bombs of various weight classes and a variety of anti-tank rockets. This branched into the extended range Fw 190G version. Development of the thoroughbred fighter continued with the Fw 190D, which began to reach Luftwaffe units in the second half of 1944 and was the result of in-line Jumo 213A-1 engine installation into a modified Fw 190A-8 airframe.

Reich defender

Although the Fw 190 never achieved the widespread usage of the competing Bf 109, its contribution to the German Air Force was certainly significant through the second half of WWII. Fw 190s saw service on the Western Front as well as in the East. As heavy fighters with imposing firepower, they found themselves integral components, from 1943 onwards, within the units tasked with the protection of the Reich from the ominous clouds of allied bombers. This is where the A-8 version was instrumental, along with its A-8/R2 armoured development. This version, with its firepower, was real threat and daunting foe for the bomber crews. From the second half of 1944, their danger was kept in check to a degree by escorting P-47s, and later by the P-51D Mustang.

This kit: Fw 190A-4 "flaps & two wing guns"

The Fw 190A-4 entered service in July 1942 and was a further development of the A-3 version. It received a new radio FuG 16Z instead of FuG VIIa and the antenna was mounted on a new short mast on the vertical stabilizer. Some aircraft were fitted with engine cooling control flaps instead of the standard slots. However, these were not an automatic system and were controlled by the pilot. Some aircraft also had the MG FF cannons removed in order to reduce take-off weight and increase manoeuvrability. These were usually flown by successful fighters who were also excellent shooters, and the armament of two MG 151 guns and two MG 17 machine guns was sufficient for them. Several factory Umrüst-Bausätze and field Rüstsatz kits were also used to adapt the weaponry to the tasks. For example, the A-4/R6 offered installation of the BR 21 rocket mortars, while the A-4/U1 subversion featured the ETC 501 central rack. In this case, however, in addition to the MG FF guns, the MG 17 machine guns were also dismantled.

ATTENTION



UPOZORNĚNÍ



ACHTUNG



ATTENTION



注意



Carefully read instruction sheet before assembling. When you use glue or paint, do not use near open flame and use in well ventilated room. Keep out of reach of small children. Children must not be allowed to suck any part, or pull vinyl bag over the head.



Před započítím stavby si pečlivě prostudujte stavební návod. Při používání barev a lepidel pracujte v dobře větrané místnosti. Lepidla ani barvy nepoužívejte v blízkosti otevřeného ohně. Model není určen malým dětem, mohlo by dojít k požití drobných dílů.

INSTRUCTION SIGNS * INSTR. SYMBOL * INSTRUKTION SINNBILDEN * SYMBOLES * 記号の説明

OPTIONAL
VOLBABEND
OHNOUTOPEN HOLE
VYVRTAT OTVORSYMETRICAL ASSEMBLY
SYMETRICKÁ MONTÁŽREMOVE
ODŘÍZNOUTREVERSE SIDE
OTOČITAPPLY EDUARD MASK
AND PAINT
POUŽÍT EDUARD MASK
NABARVITPLEASE, CHECK THE LATEST VERSION OF THE INSTRUCTION ON www.eduard.com

PARTS



DÍLY



TEILE



PIÈCES



部品

PLASTIC PARTS

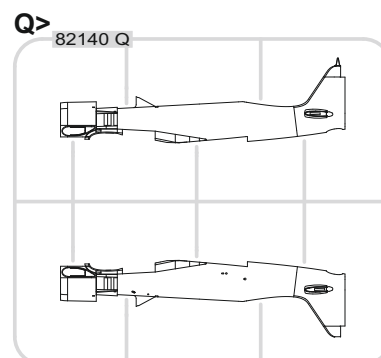
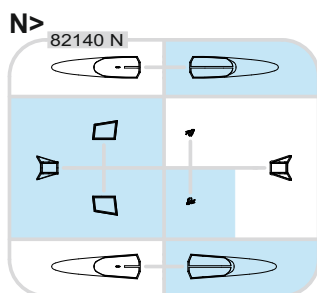
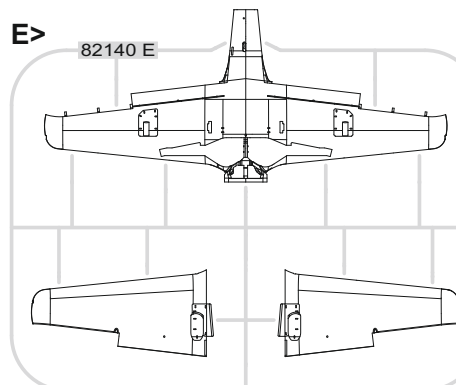
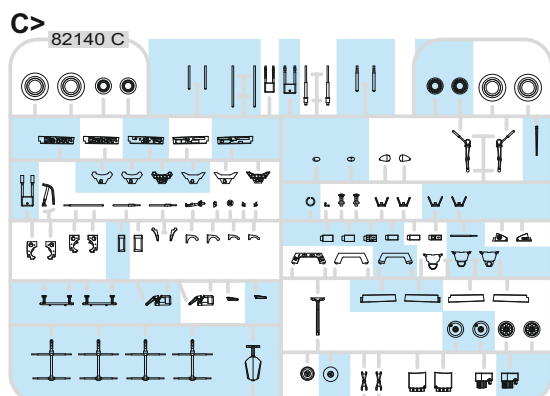
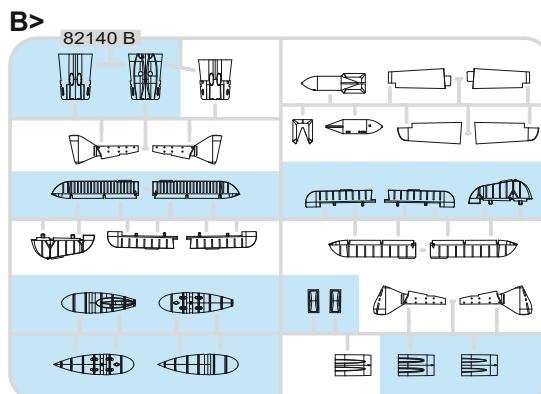
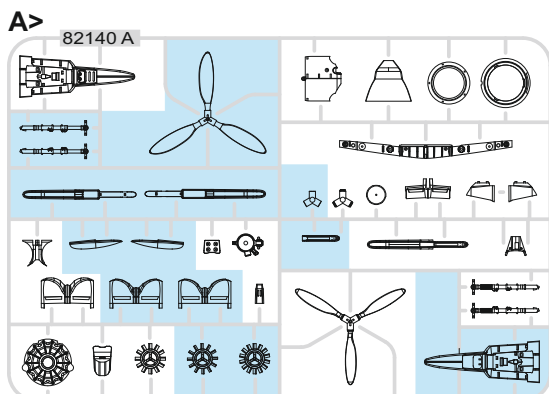

-Parts not for use. -Teile werden nicht verwendet. -Pièces à ne pas utiliser. -Tyto díly nepoužívejte při stavbě. - 使用しない部品

COLOURS



BARVY



FARBEN



PEINTURE



色

GSi Creos (GUNZE)		
AQUEOUS	Mr.COLOR	
H1	C1	WHITE
H2	C2	BLACK
H11	C62	FLAT WHITE
H12	C33	FLAT BLACK
H47	C41	RED BROWN
H64	C17	RLM71 DARK GREEN
H65	C18	RLM70 BLACK GREEN
H67	C115	RLM65 LIGHT BLUE
H68	C36	RLM74 DARK GRAY
H69	C37	RLM75 GRAY
H70	C60	RLM02 GRAY
H77	C137	TIRE BLACK

AQUEOUS	Mr.COLOR	
H80	C54	KHAKI GREEN
H90	C47	CLEAR RED
H94	C138	CLEAR GREEN
H310	C310	BROWN
H413	C113	RLM04 YELLOW
H414	C114	RLM23 RED
H416	C116	RLM66 BLACK GRAY
H417	C117	RLM76 LIGHT BLUE
Mr.METAL COLOR		
	MC213	STEEL
	MC214	DARK IRON
Mr.COLOR SUPER METALLIC		
	SM201	SUPER FINE SILVER

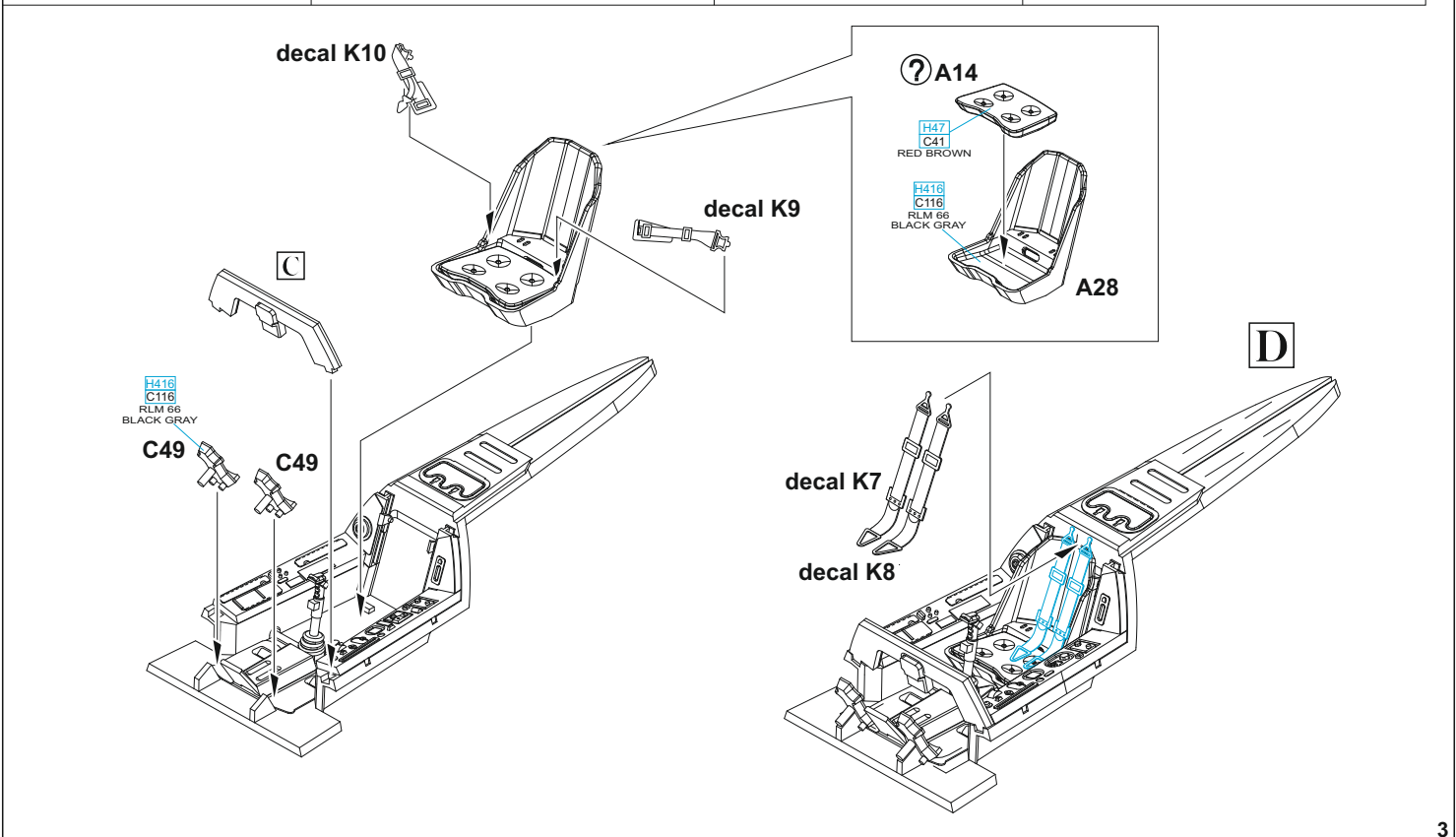
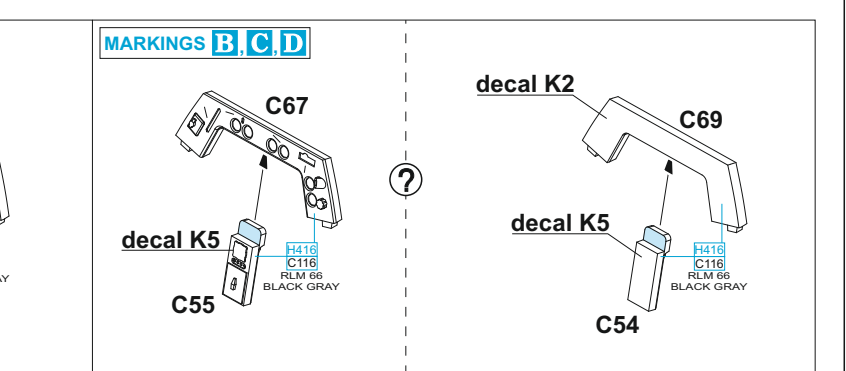
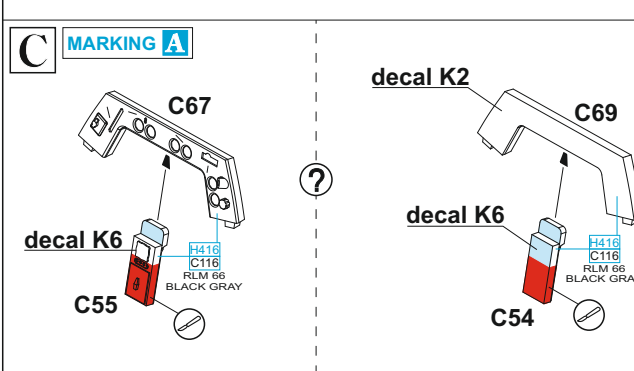
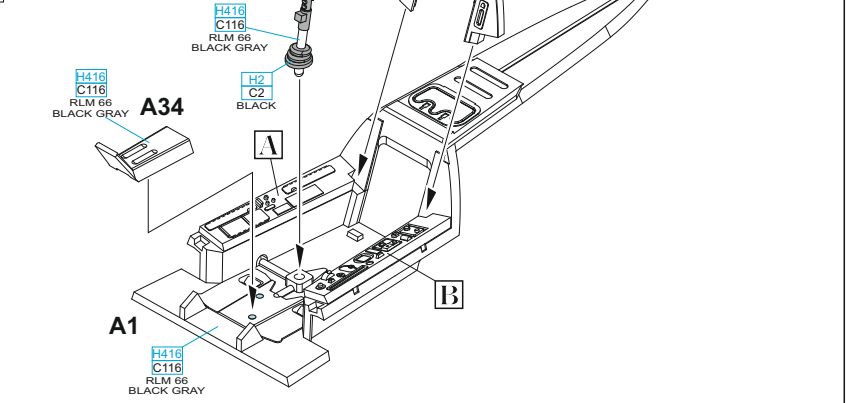
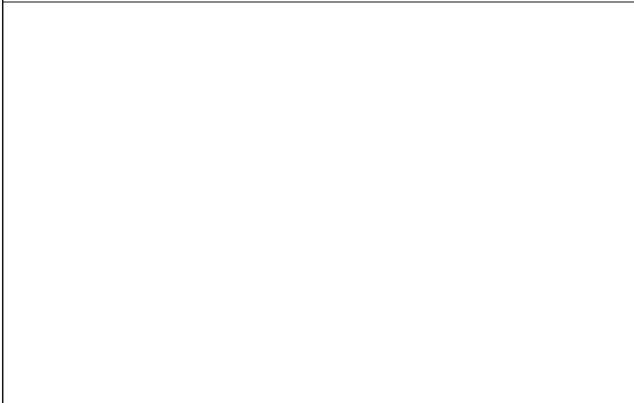
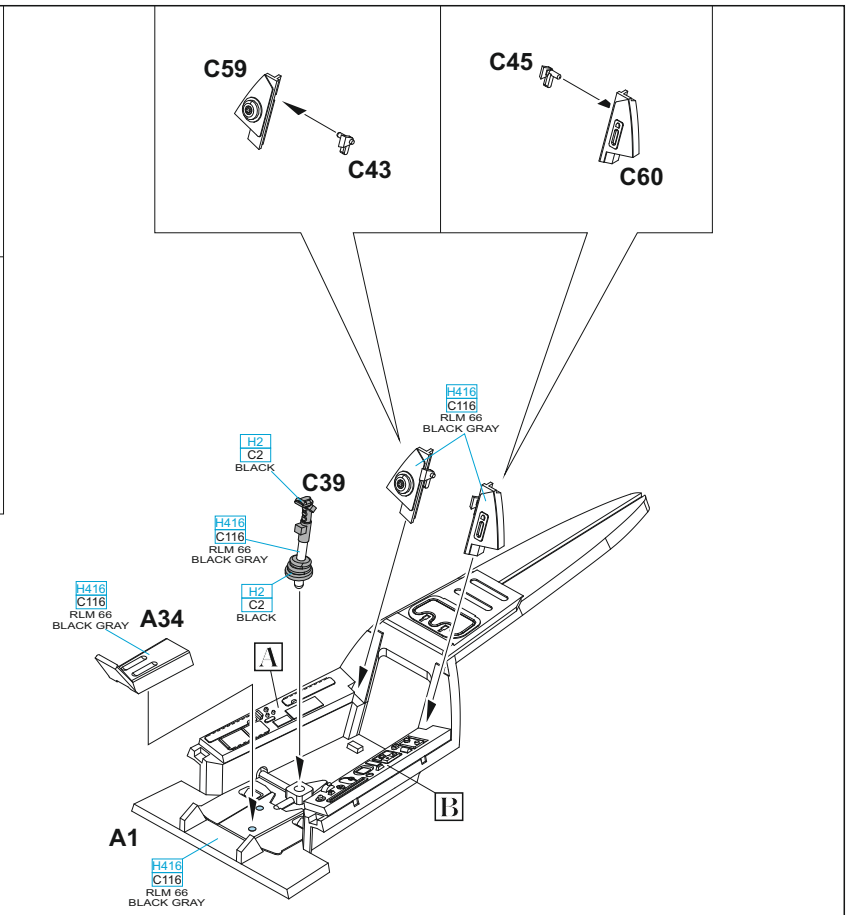
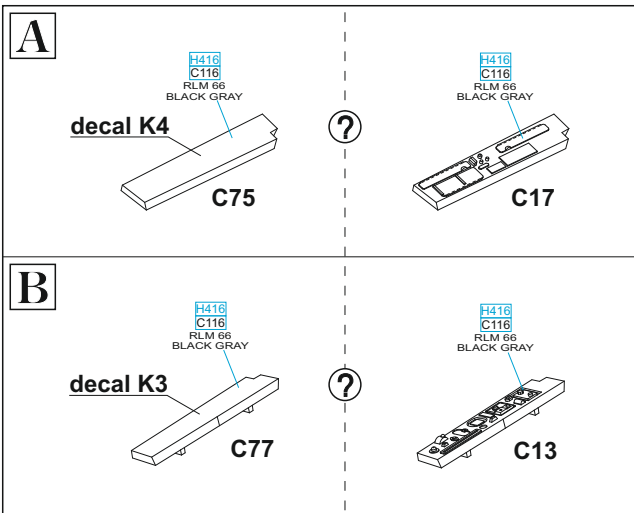

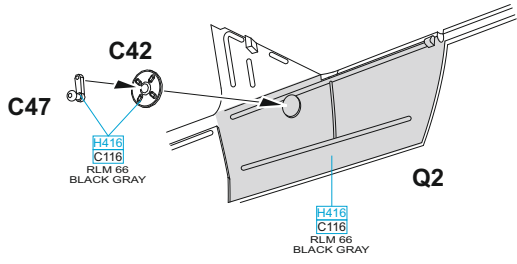
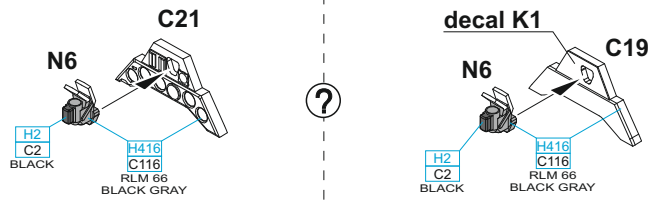
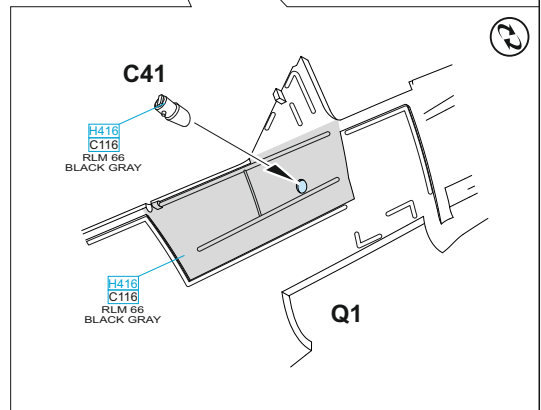
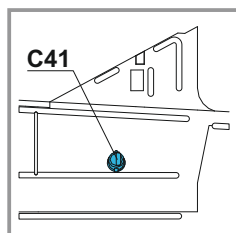
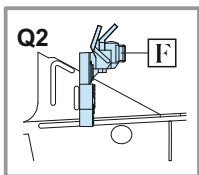
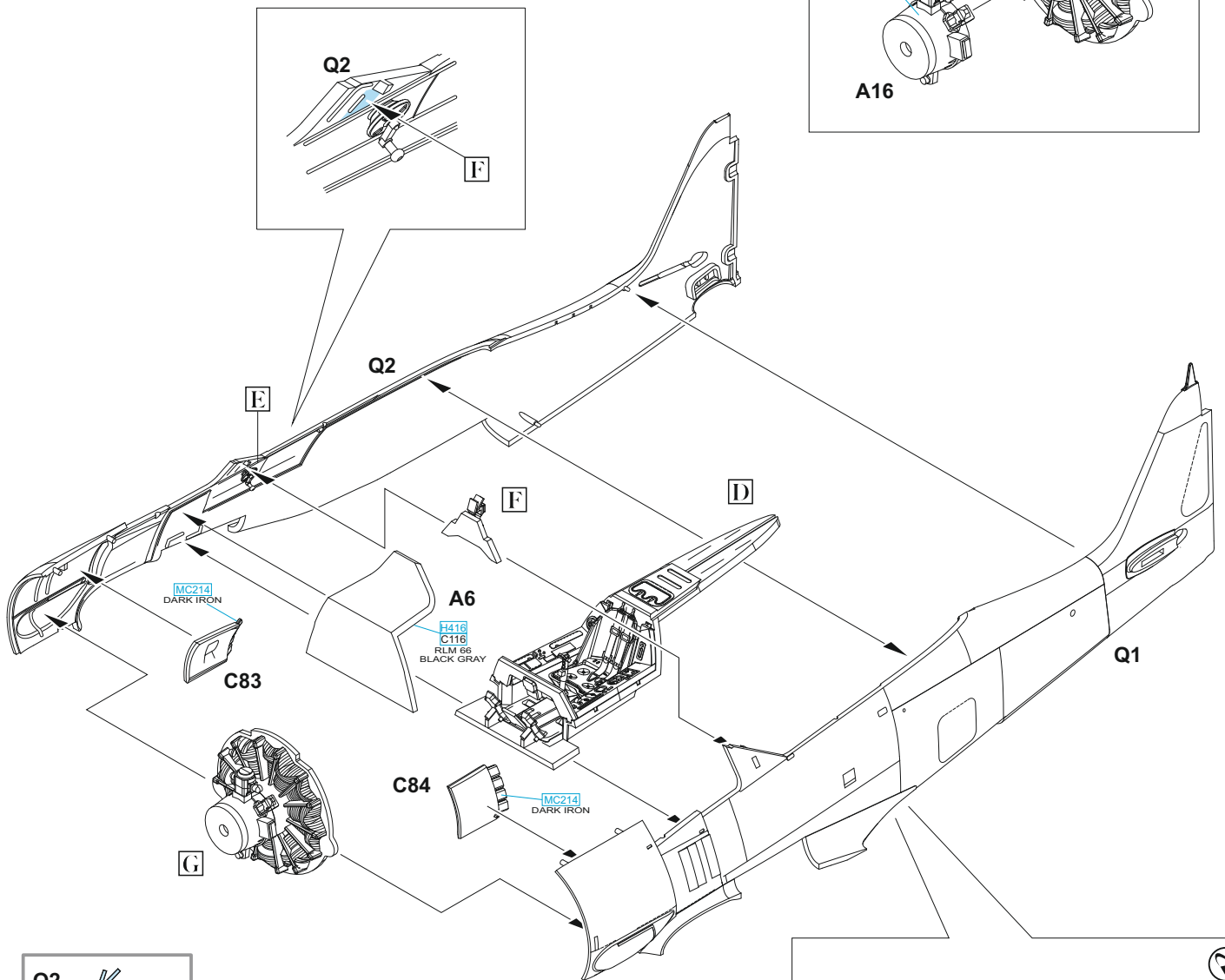
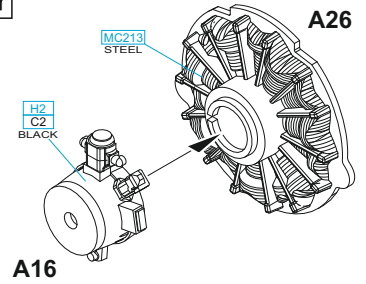
E**F****G**

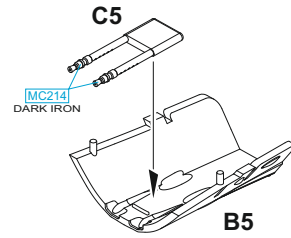
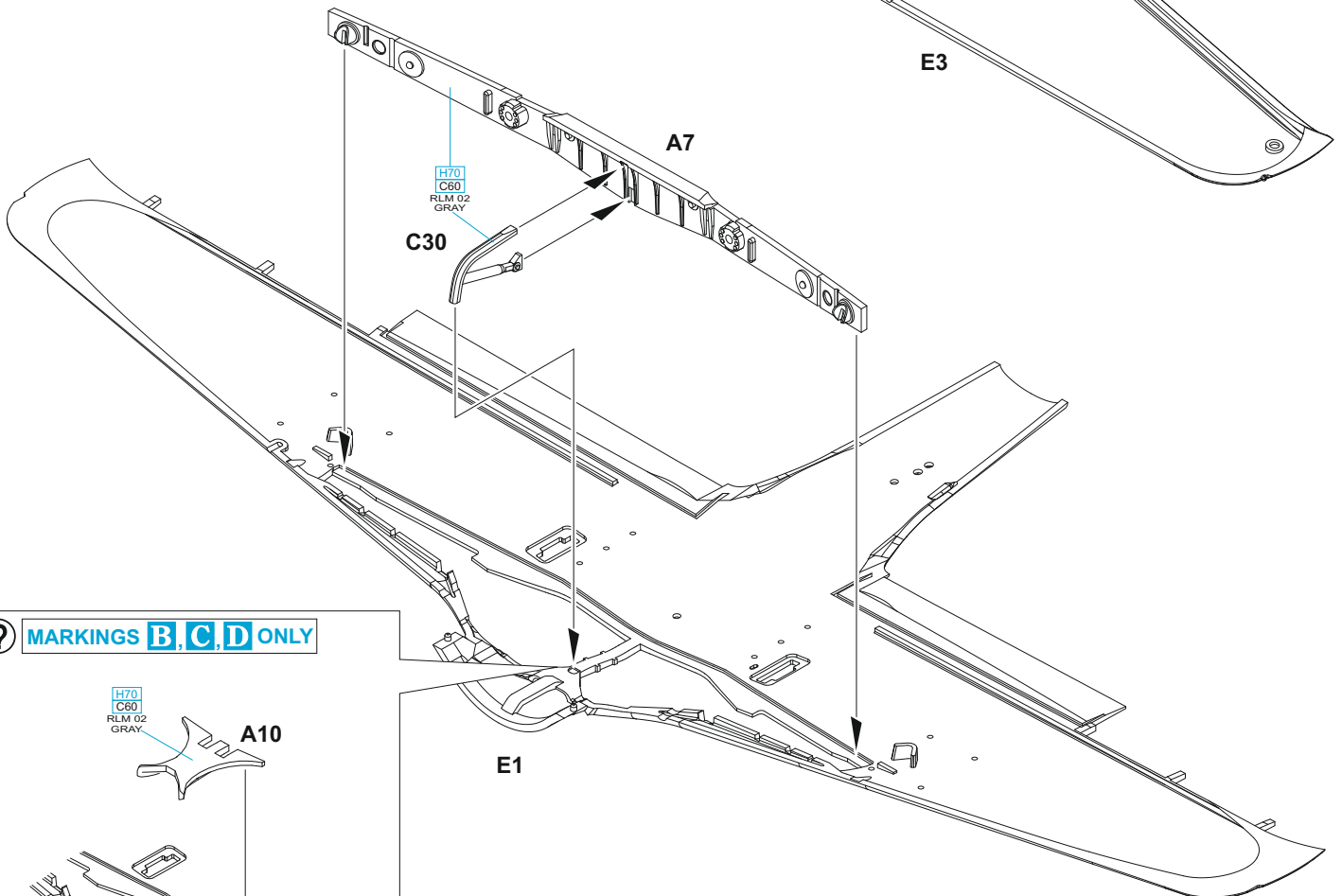
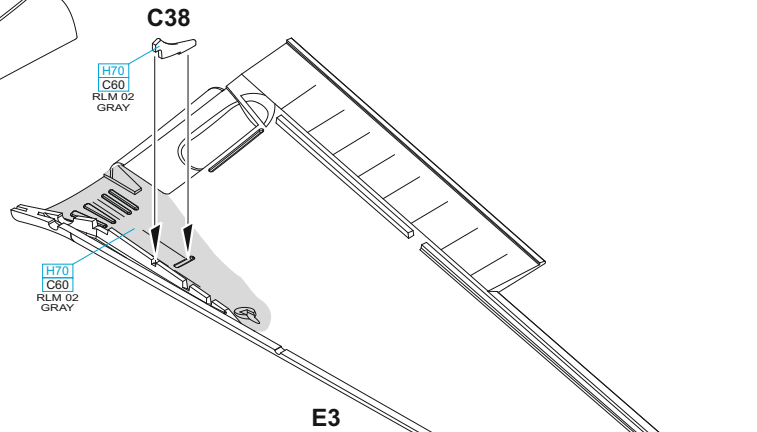
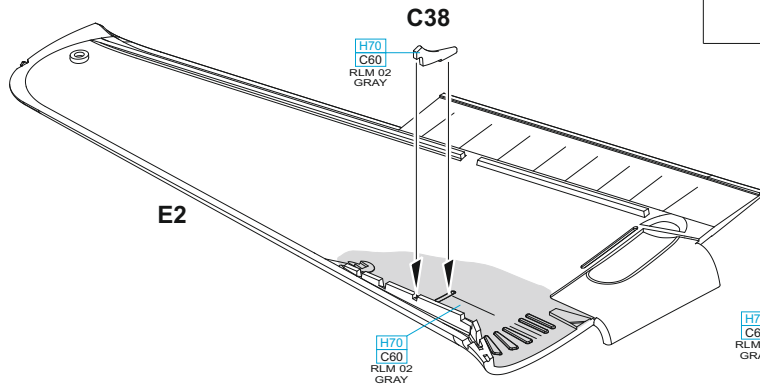
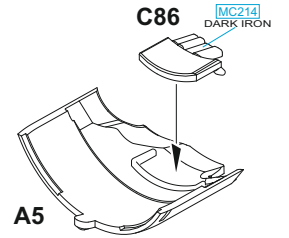
H**I**

? MARKINGS **B, C, D** ONLY

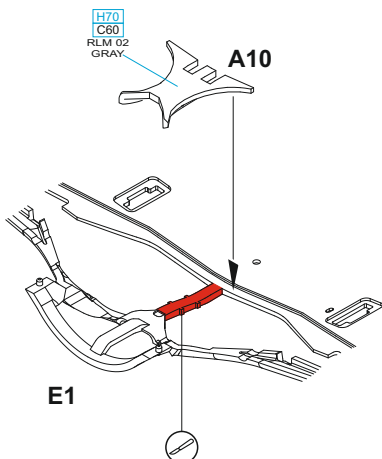

J

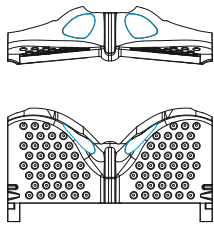
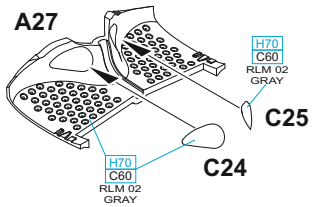

K

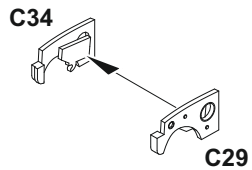

L

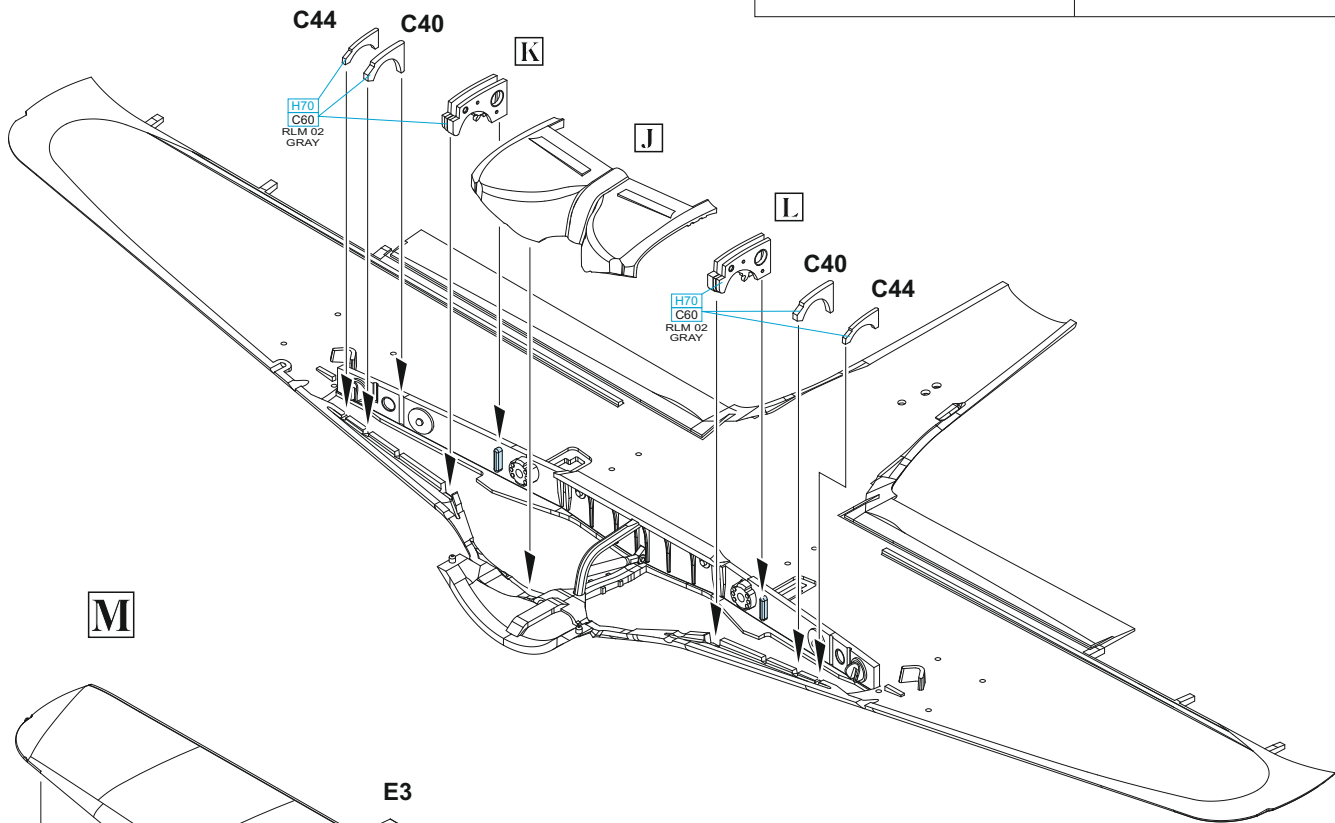
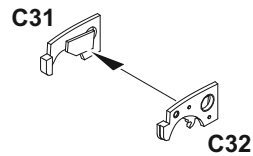

M

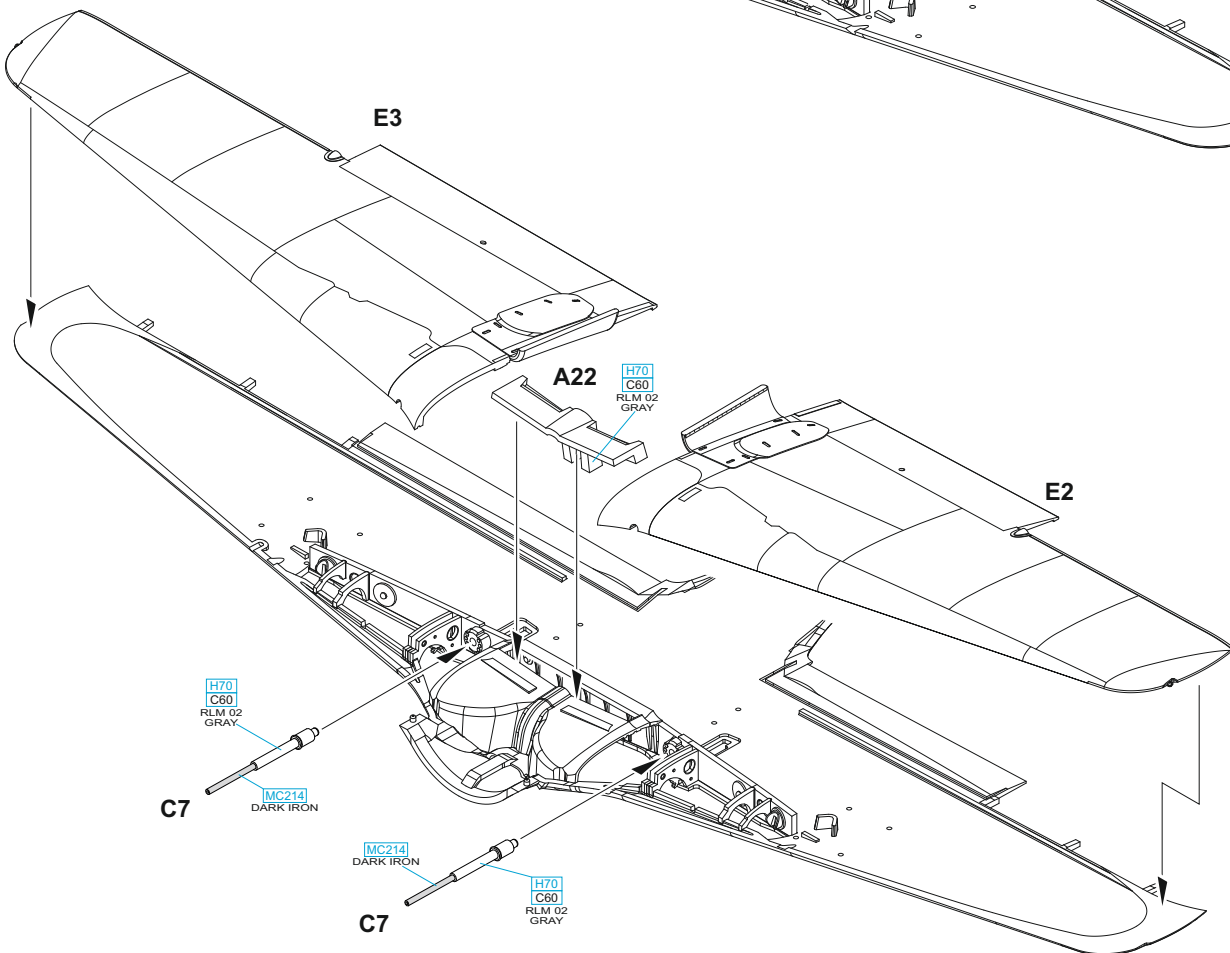

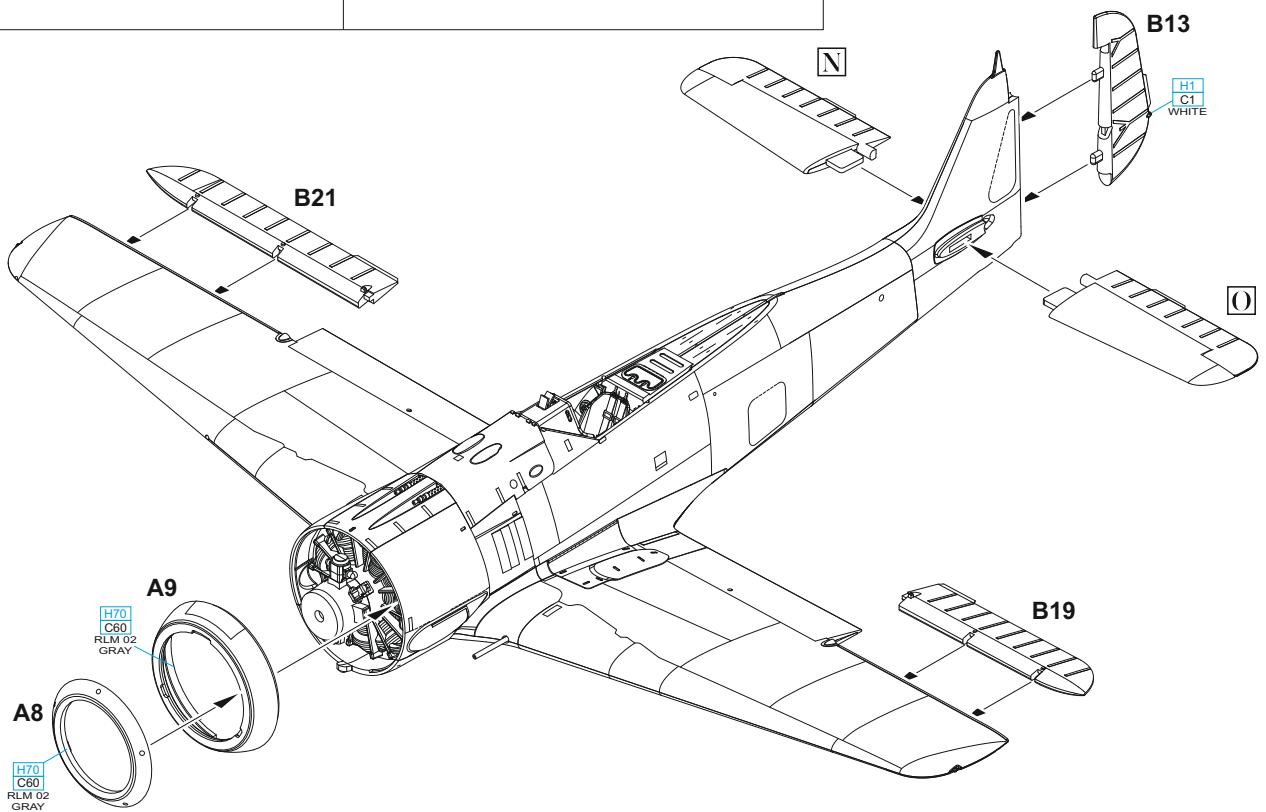
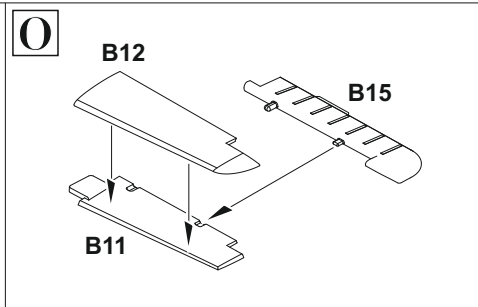
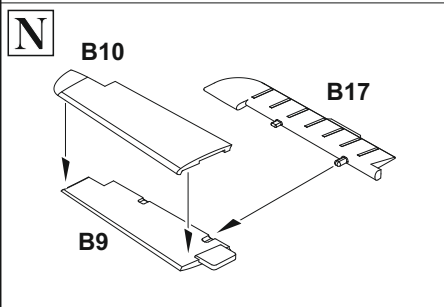
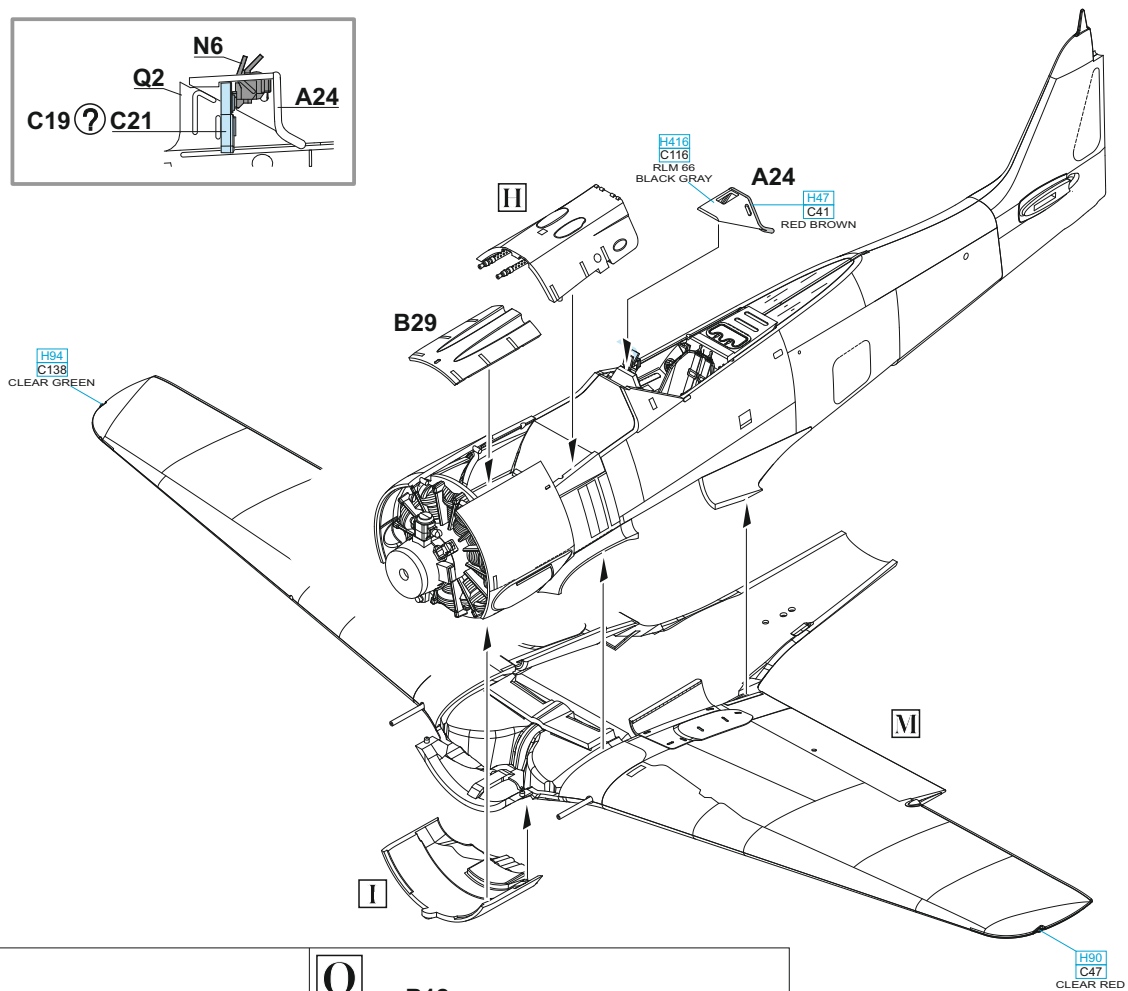
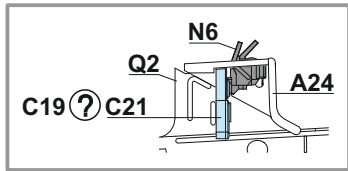

P B2 - MARKINGS A, D
 B33 - MARKINGS B, C

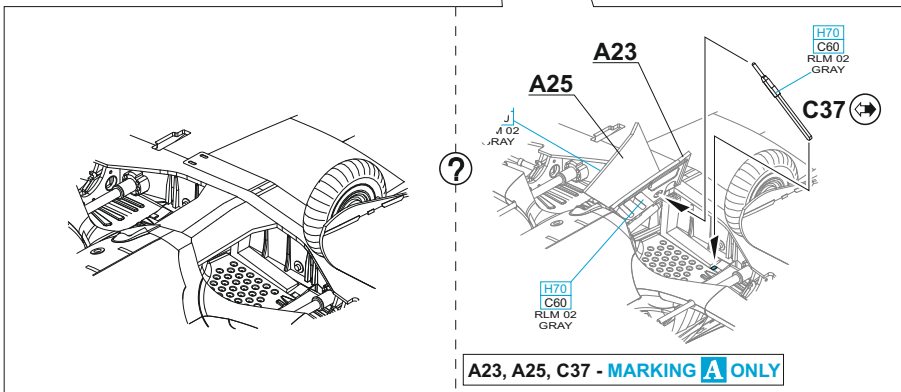
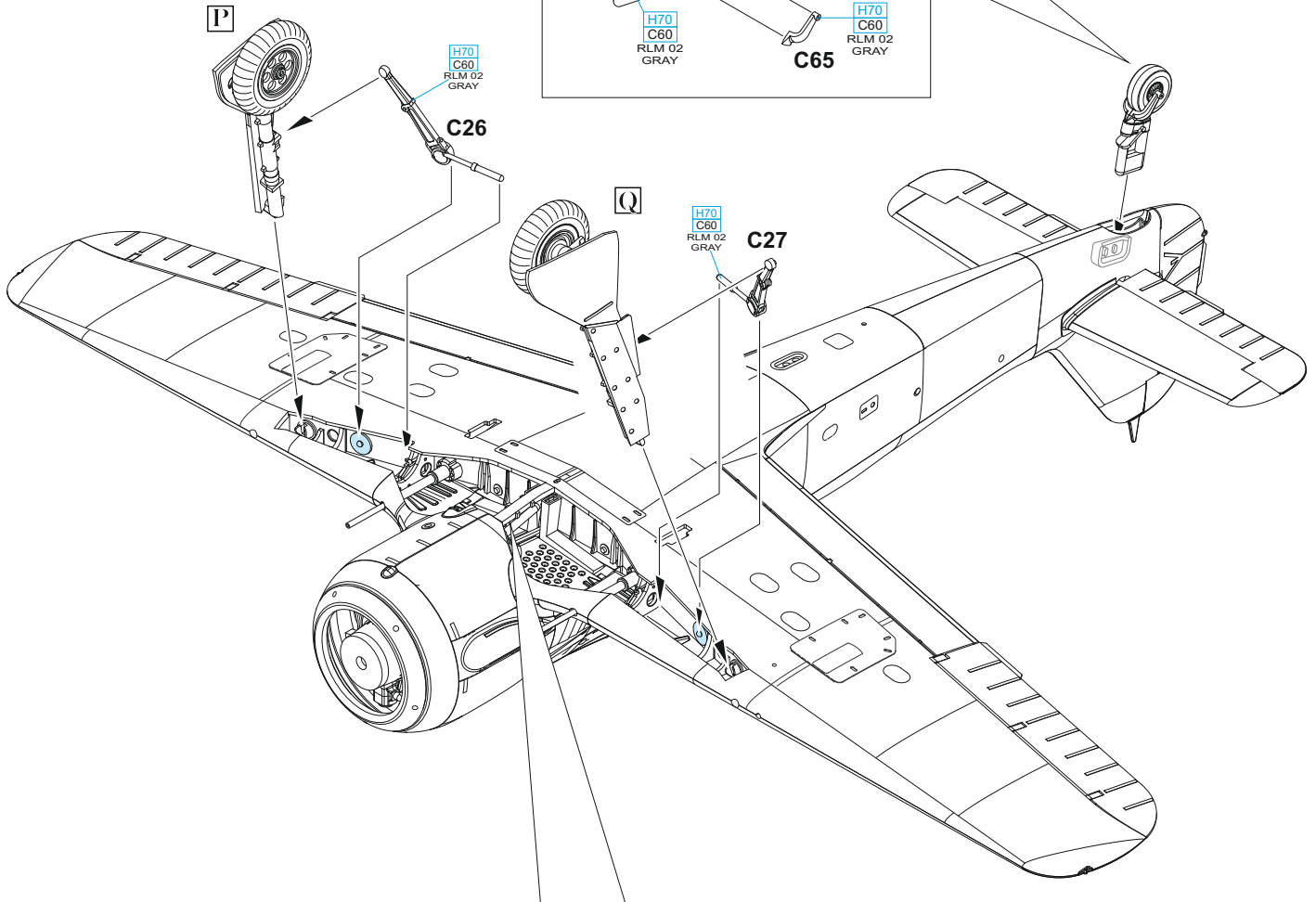
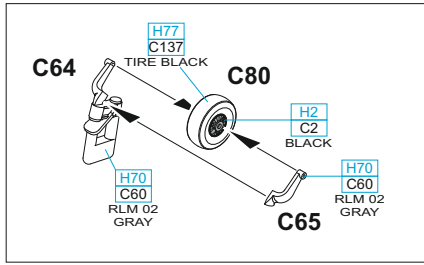
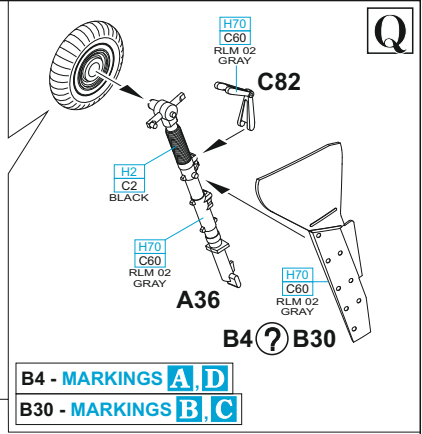
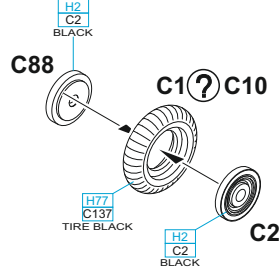
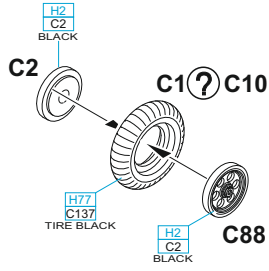
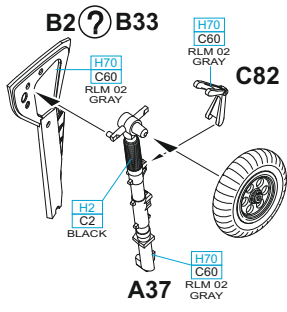

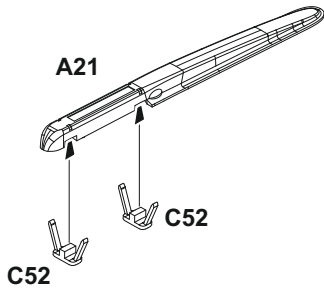
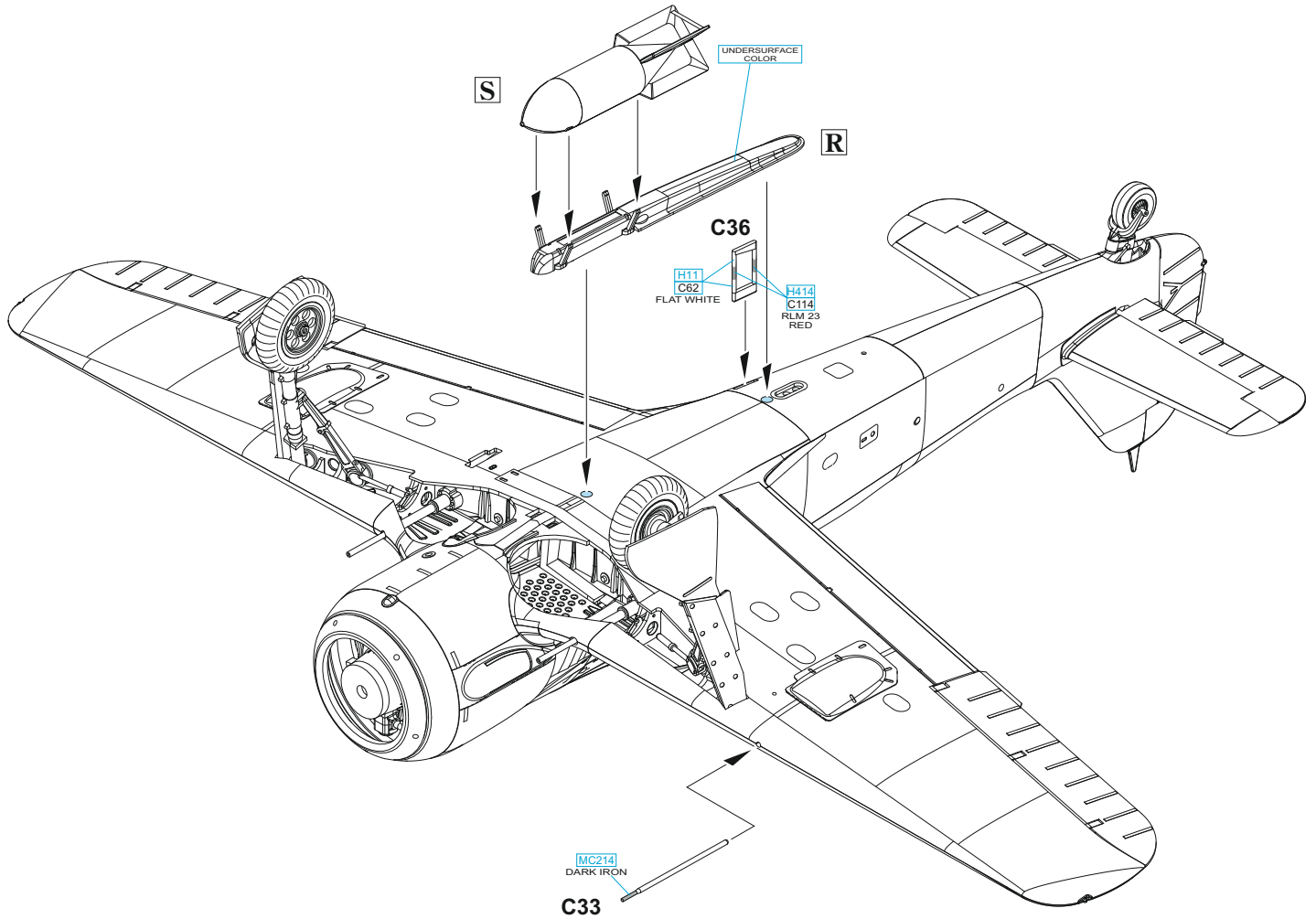
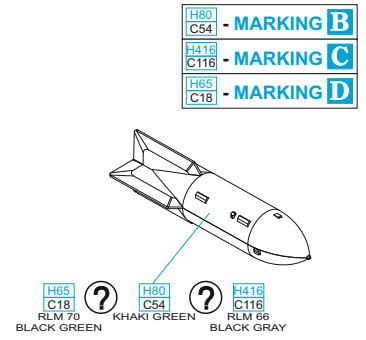
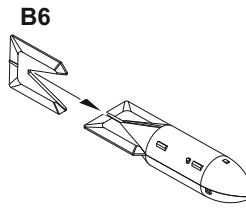
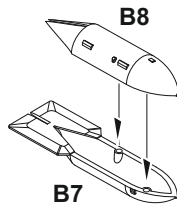
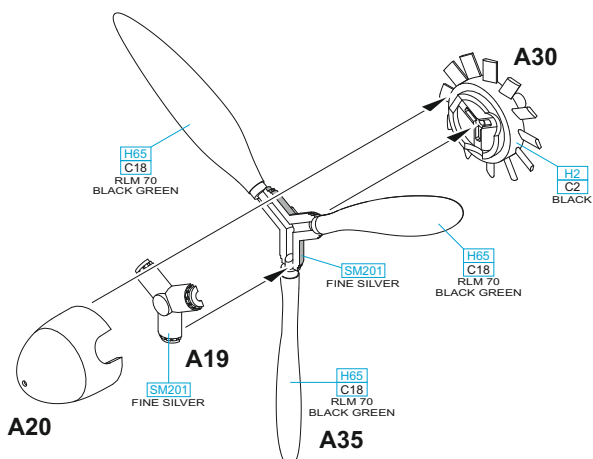
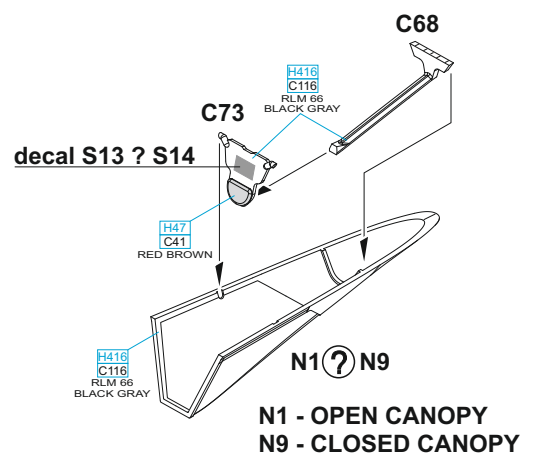
R**S****T****U**

OPEN CANOPY

N1 U

H416
C116
RLM 66
BLACK GRAY

N8

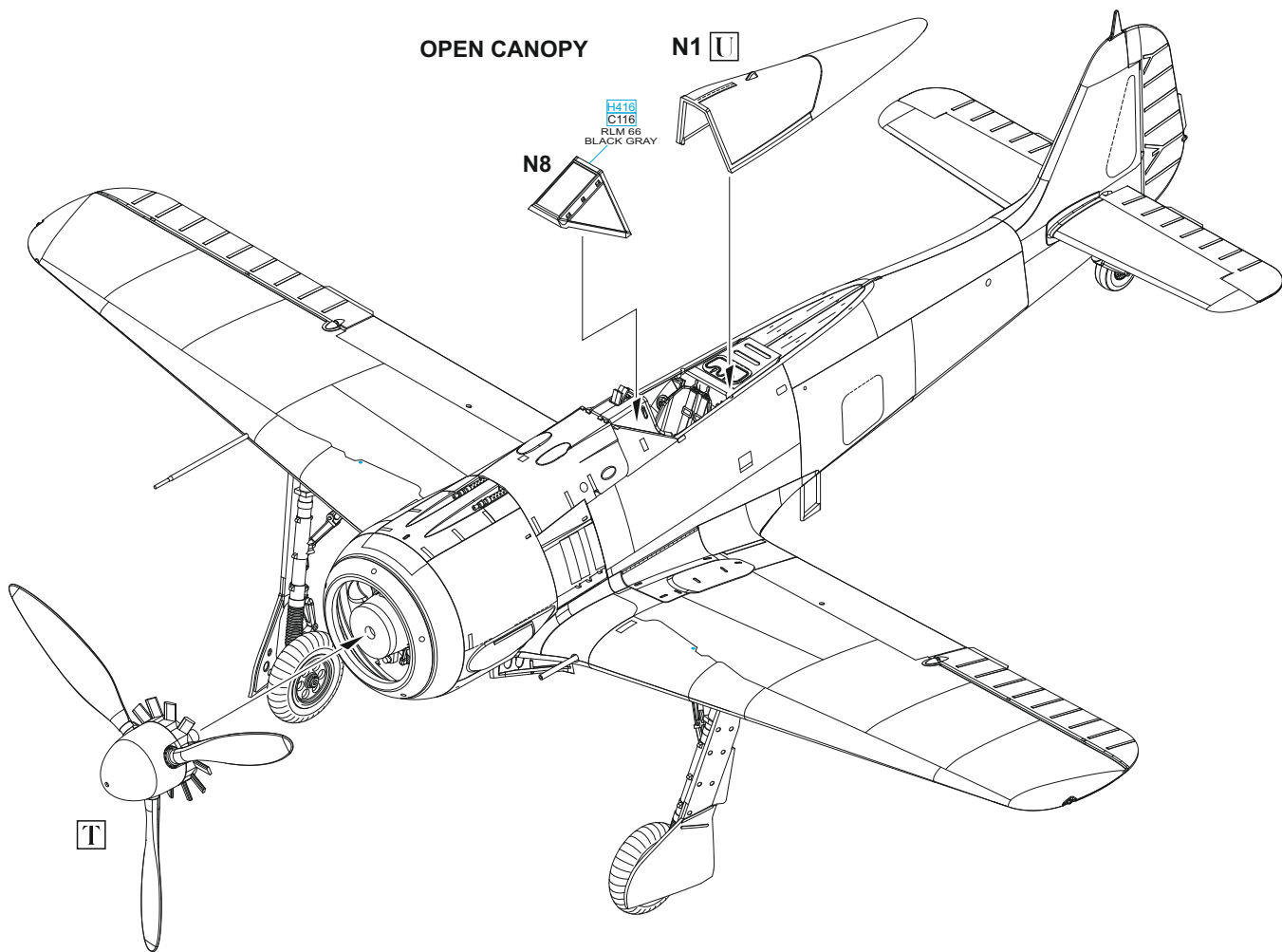

CLOSED CANOPY

N9 U

H416
C116
RLM 66
BLACK GRAY

N8

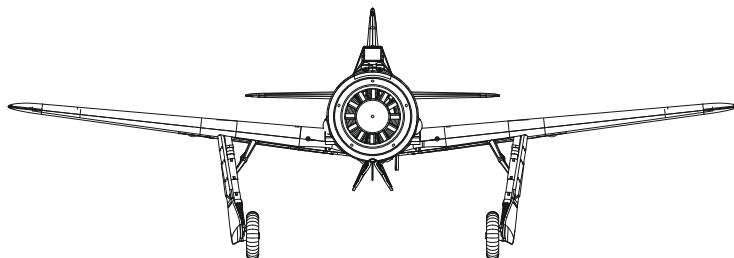
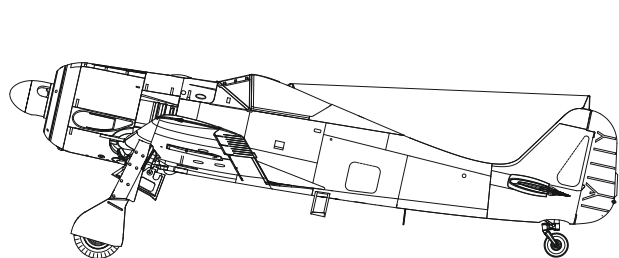
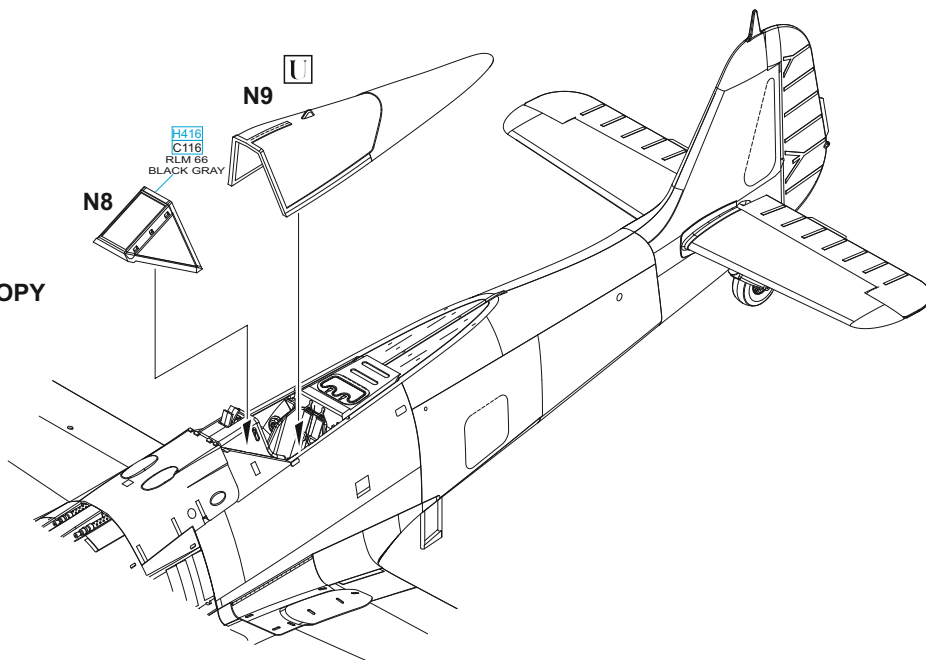

A WNr. 0142481, Fw. Otto Kittel, 2./JG 54, Krasnogvardejsk, Soviet Union, February 1943

Otto Kittel was born on February 21, 1917, to German parents in Korunov (German: Kronsdorf, since 1945 Krasov) near Krnov in Austria-Hungary. After the declaration of the Czechoslovakia, the Krnov region became part of it, but after the Munich Agreement it was one of the territories that Czechoslovakia had to cede to Germany under pressure from the Great Powers. The inhabitants claiming German nationality subsequently became German citizens. Kittel was apprenticed as a car mechanic in Mladá Boleslav and joined the Luftwaffe in 1939. He completed his first combat deployment during the fighting in Yugoslavia in the ranks of JG 54, which was deployed in East Prussia to support Army Group North in the advance on Leningrad during the attack on the USSR. On June 24, 1941, Otto Kittel scored his first two aerial victories, and on September 14, 1943, he achieved his 100th kill. However, he did not survive the war. His aircraft went down in flames near Dzhūkste, Latvia, after a dogfight with a formation of 14 Il-2s. However, it is not clear when this occurred, it is stated to be either February 14 or 16, 1945. During World War II, he shot down 267 enemy aircraft, all on the Eastern Front, ranking him 4th in the list of Luftwaffe aces.

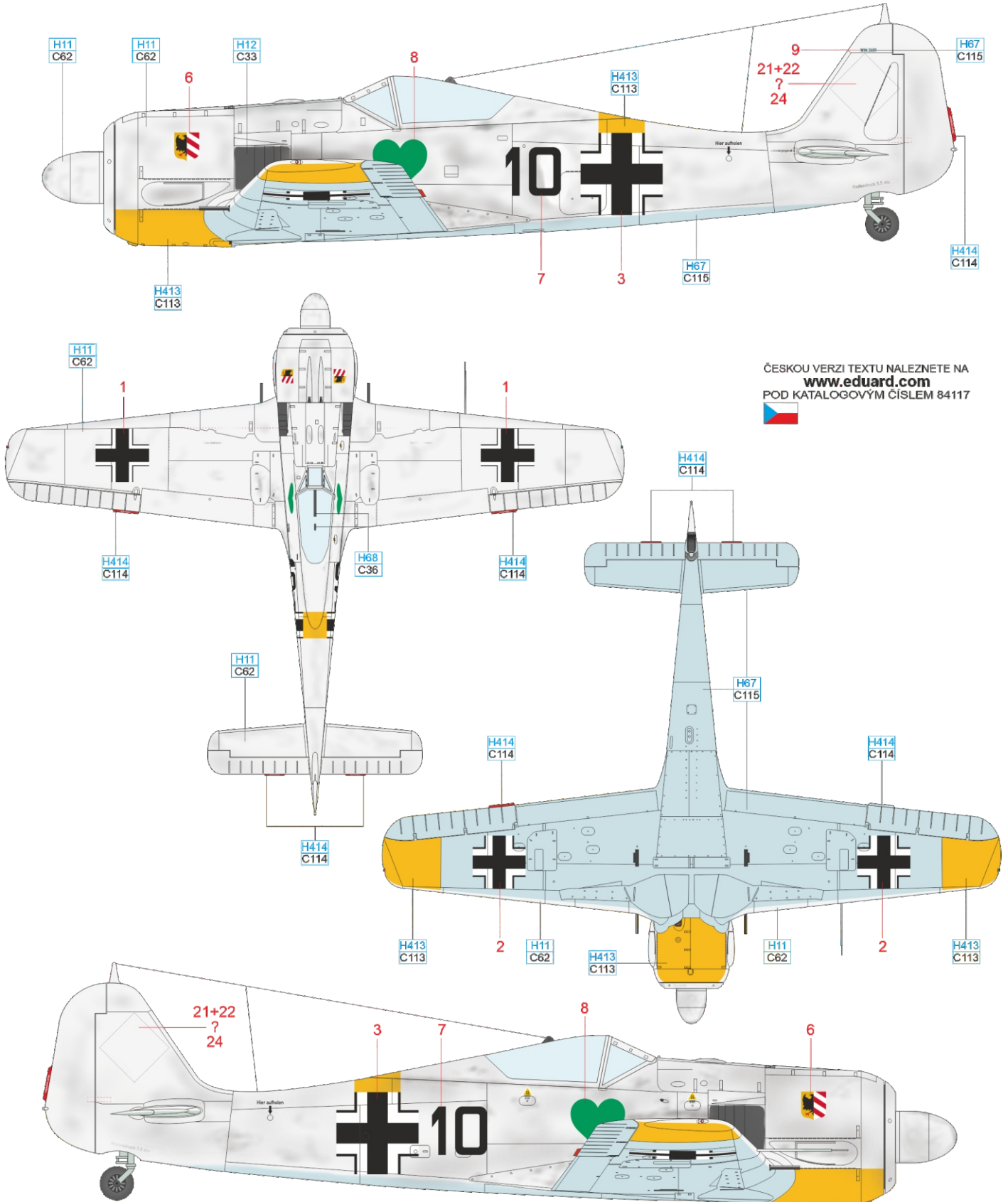

ČESKOU VERZÍ TEXTU NALEZNETE NA
www.eduard.com
 POD KATALOGOVÝM ČÍSLEM 84117



RLM 65	H67 C115	RLM 74	H68 C36	RLM 04	H413 C113	RLM 23	H414 C114	WHITE	H11 C62	BLACK	H12 C33
--------	-------------	--------	------------	--------	--------------	--------	--------------	-------	------------	-------	------------

B Lt. Leopold Wenger, 10./JG 2, Caen-Carpiquet, France, February 1943

At the end of 1941, the Luftwaffe considered a resumption of the bombing of Great Britain and coastal shipping. It was ordered that every fighter unit taking part in operations against Great Britain would include one Staffel for the purposes of the so-called "hit and run" bombing missions. This role was taken up by 10.(Jabo) Staffel within JG 2. Under the command of Oblt. Frank Liesendahl, the unit sank twenty ships for a total of 630,000 BRT of shipping in four months. Wenger's aircraft carried the standard day camouflage scheme of Luftwaffe fighters consisting of RLM 74/75/76. The fox biting a ship in two was the insignia of 10.(Jabo) Staffel. One of the pilots of this unit was Leopold Wenger, born on November 19, 1921 in Graz. He was killed on April 10, 1945, when he was shot down over Vienna.

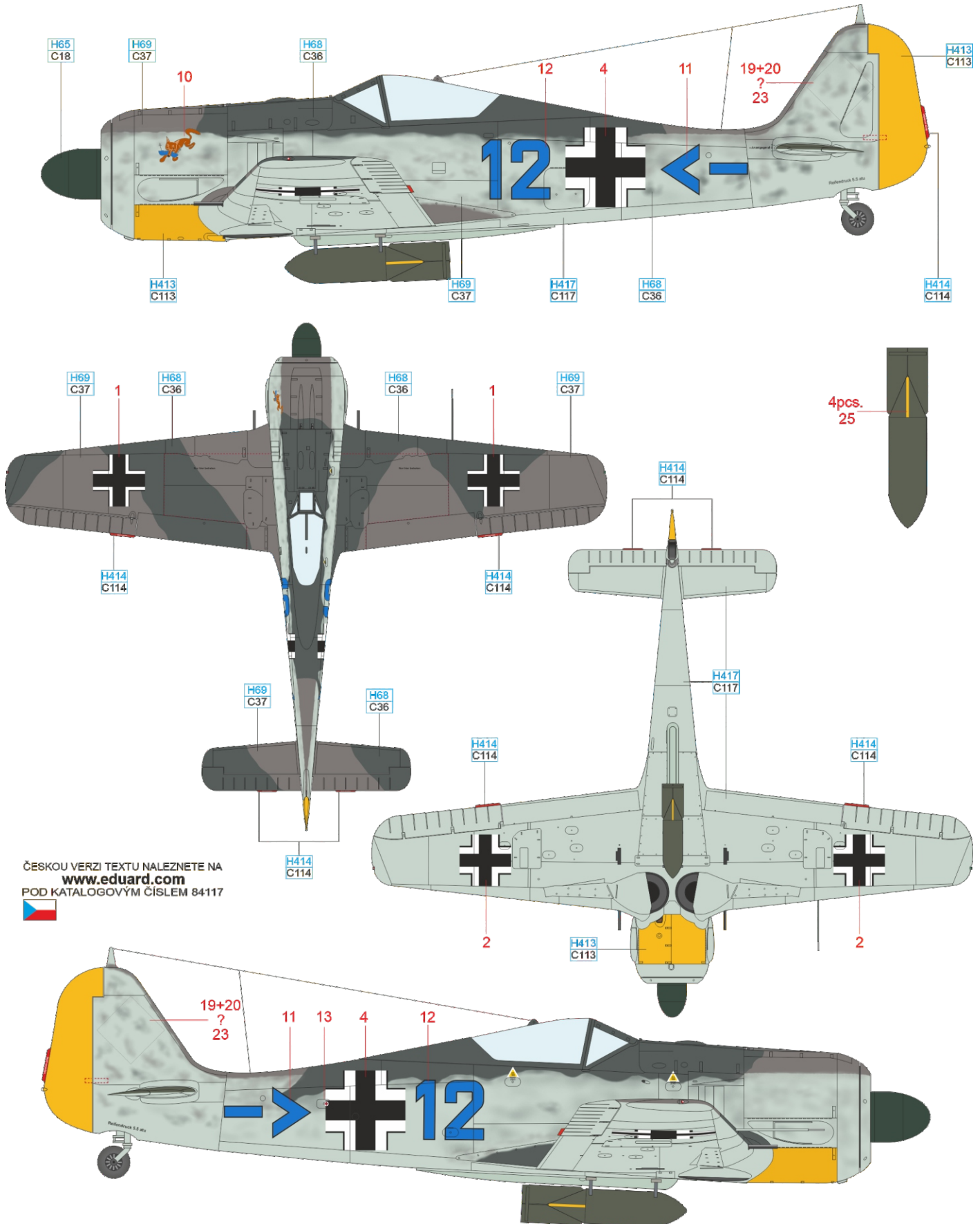

ČESKOU VERZI TEXTU NALEZNETE NA
www.eduard.com
 POD KATALOGOVYM ČÍSLEM 84117



- RLM 76 H417
C117
- RLM 75 H69
C37
- RLM 74 H68
C36
- RLM 70 H65
C18
- RLM 04 H413
C113
- RLM 23 H414
C114

An order dated November 30, 1942 redesignated III./ZG 2 as III./SKG 10, but the unit maintained its combat assignment for ground support, bombing and destroying of enemy ground assets including airfields and ports in Tunisia. III./SKG 10 operated in the area until April 30, 1943, when they handed over their remaining four aircraft to II./Schl.G. 2, the unit they shared a base with. During combat operations, pilots of III./SKG 10 destroyed hundreds of Allied tanks and other ground equipment, shot down thirteen aircraft and sank or damaged twelve ships. The aircraft flown by Feldwebel Seif was camouflaged in RLM 74/75/76. The white fuselage band was applied to aircraft operating in the MTO. The port side of the engine cowl sported the III./SKG 10 unit marking, a yellow winged arrow on a blue shield.

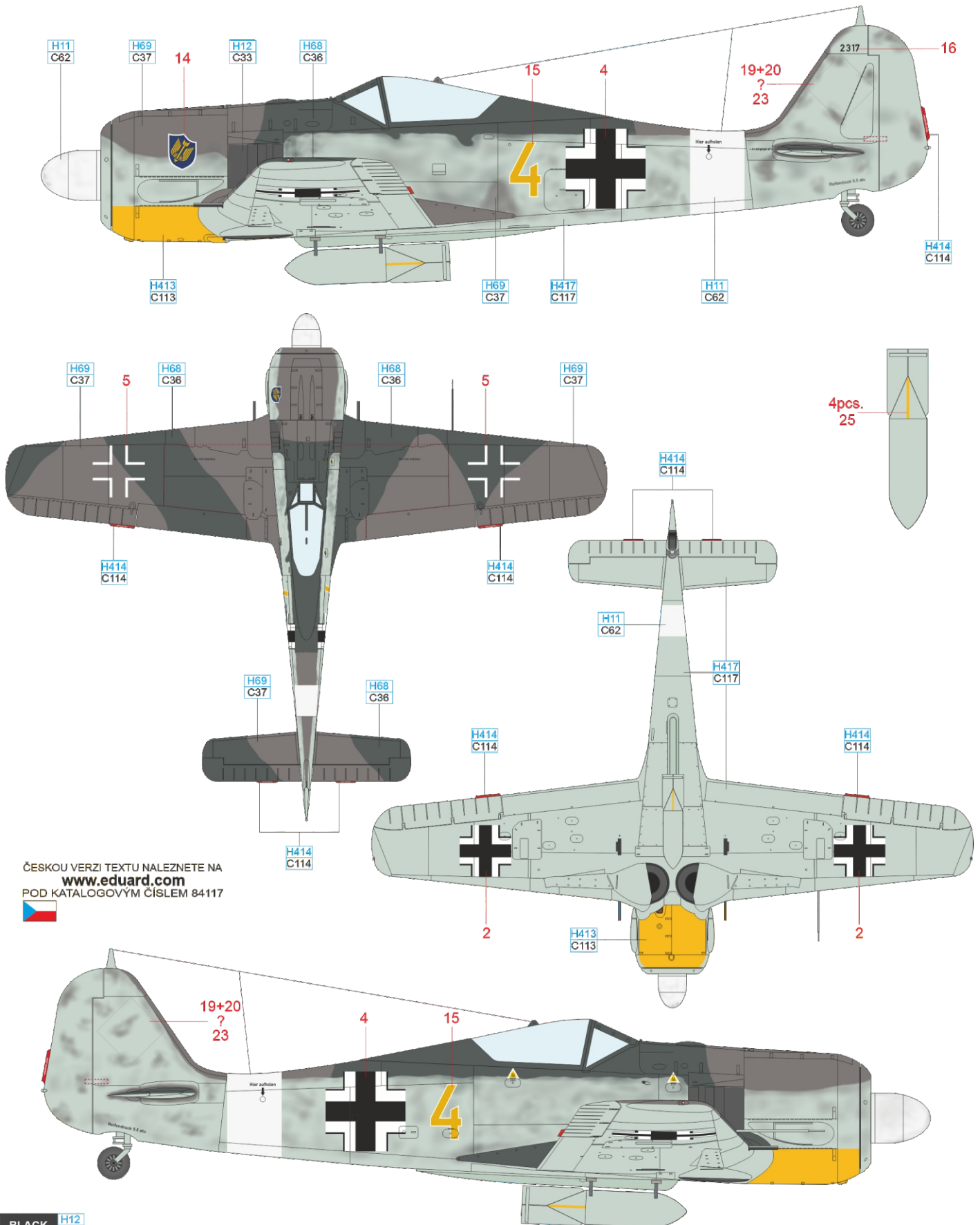

ČESKOU VERZI TEXTU NALEZNETE NA
www.eduard.com
 POD KATALOGOVÝM ČÍSLEM 84117



BLACK	H12 C33
RLM 76	H417 C117
RLM 75	H69 C37
RLM 74	H68 C36
RLM 04	H413 C113
RLM 23	H414 C114
WHITE	H11 C62

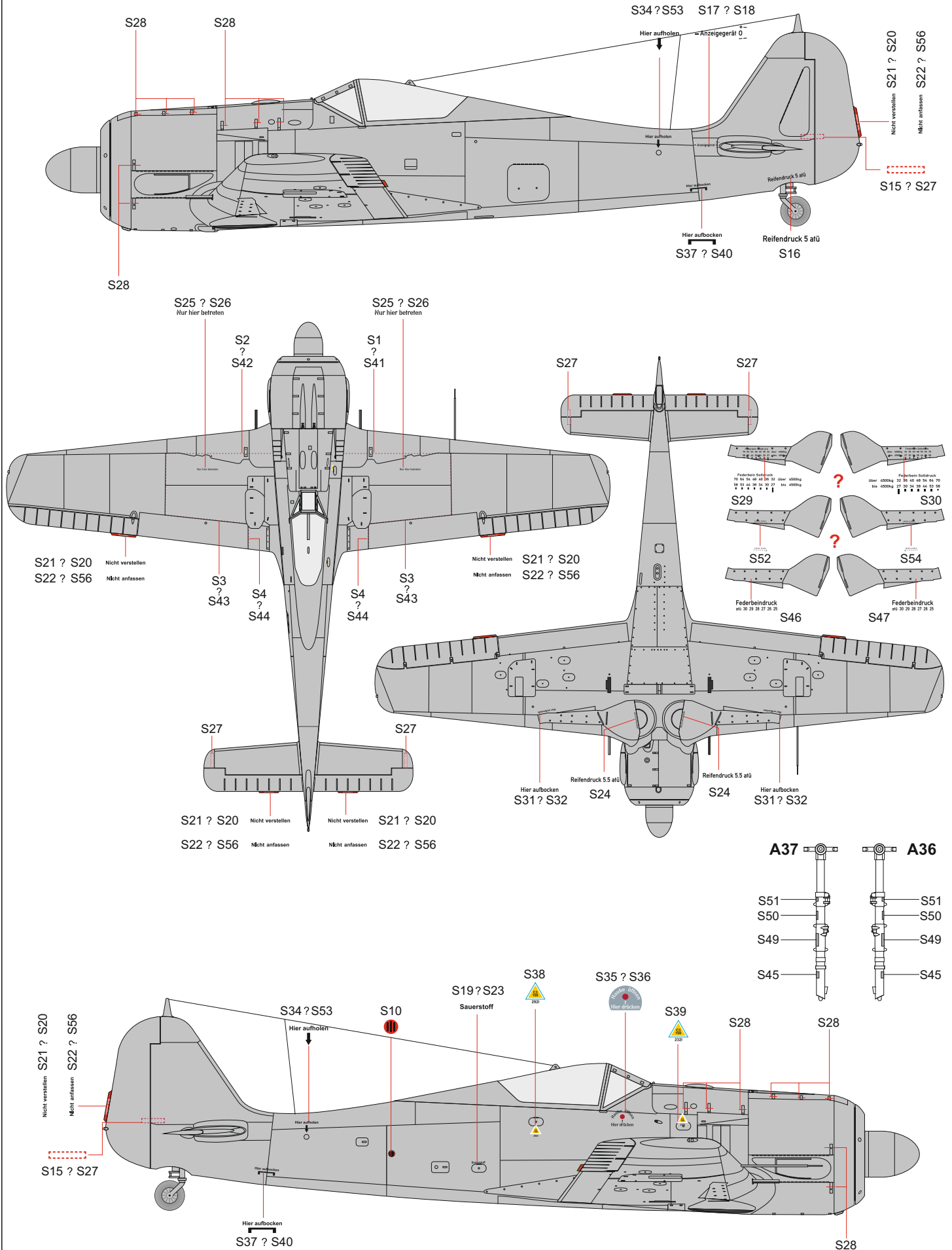

- 48936 Fw 190A-4 landing flaps (PE-Set)
- FE863 Fw 190A seatbelts STEEL (PE-Set)
- 648351 Fw 190A-4 cockpit (Brassin)
- 648352 Fw 190A-4 engine (Brassin)
- 648354 Fw 190A-4 fuselage guns (Brassin)
- 648355 Fw 190A-4 engine & fuselage guns (Brassin)
- 648356 Fw 190A wingroot gun bays (Brassin)
- 648366 Fw 190A propeller (Brassin)
- 648371 Fw 190A control surfaces early (Brassin)
- 648381 Fw 190A exhaust stacks (Brassin)
- 648778 Luftwaffe rudder pedals PRINT (Brassin)
- SIN64837 Fw 190A-4 advanced (Brassin)
- SIN64839 Fw 190A-4 essential (Brassin)
- D48038 Fw 190A-4 national insignia (Decal Set)
- EX587 Fw 190A TFace (Mask)

Cat. No. 648778

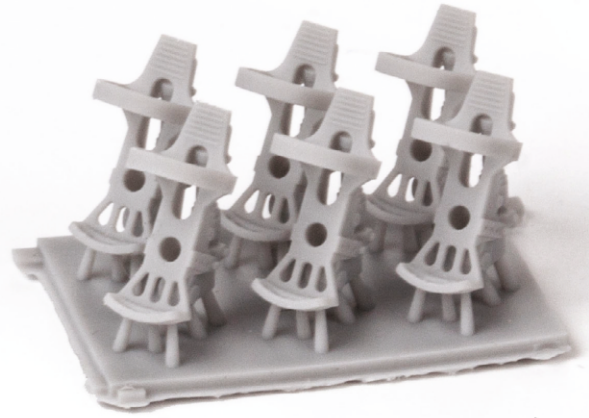

Cat. No. 648366



Cat. No. 648355

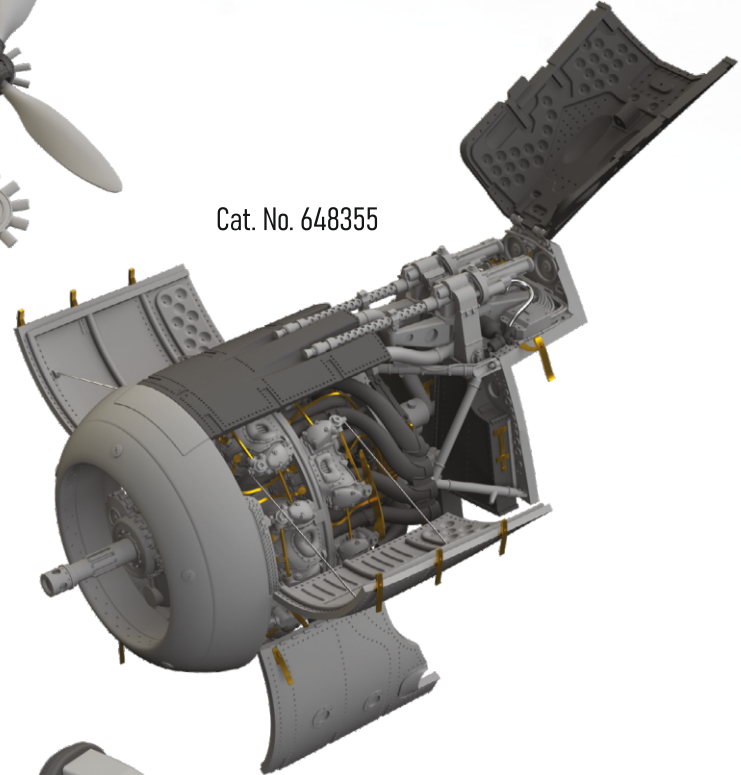

Cat. No. 648356

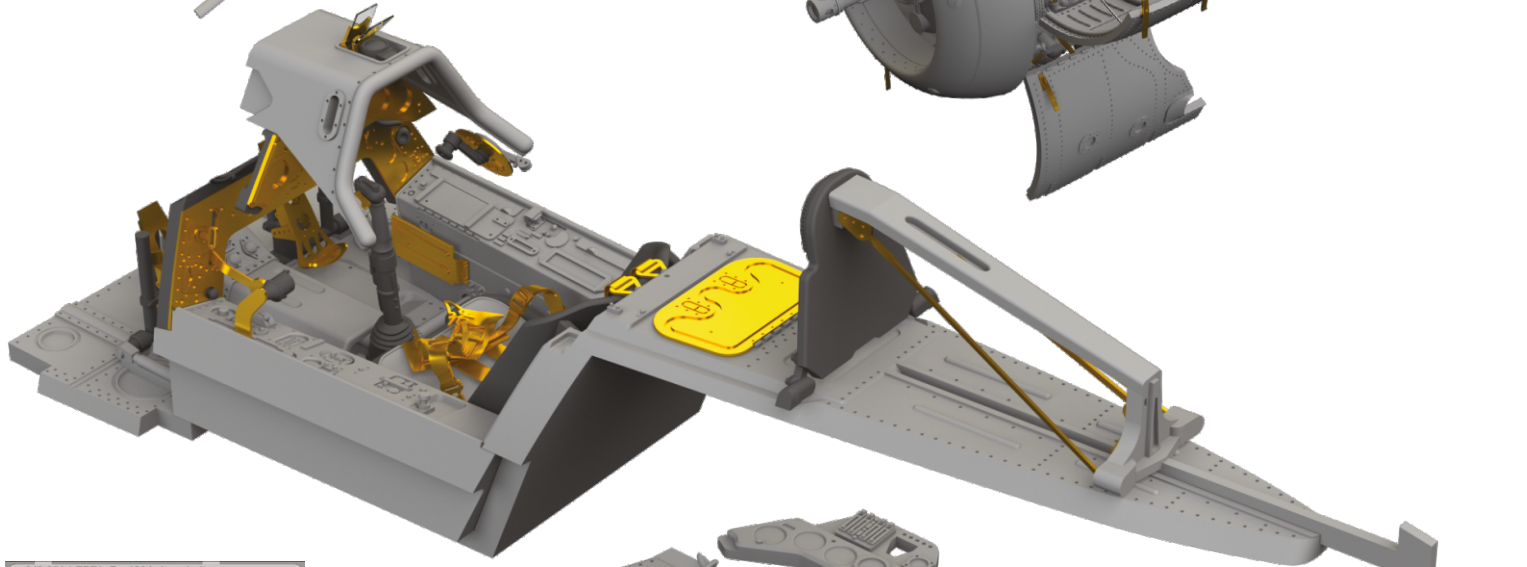

Cat. No. 648351

