

P-40 E Thru N

Step 1

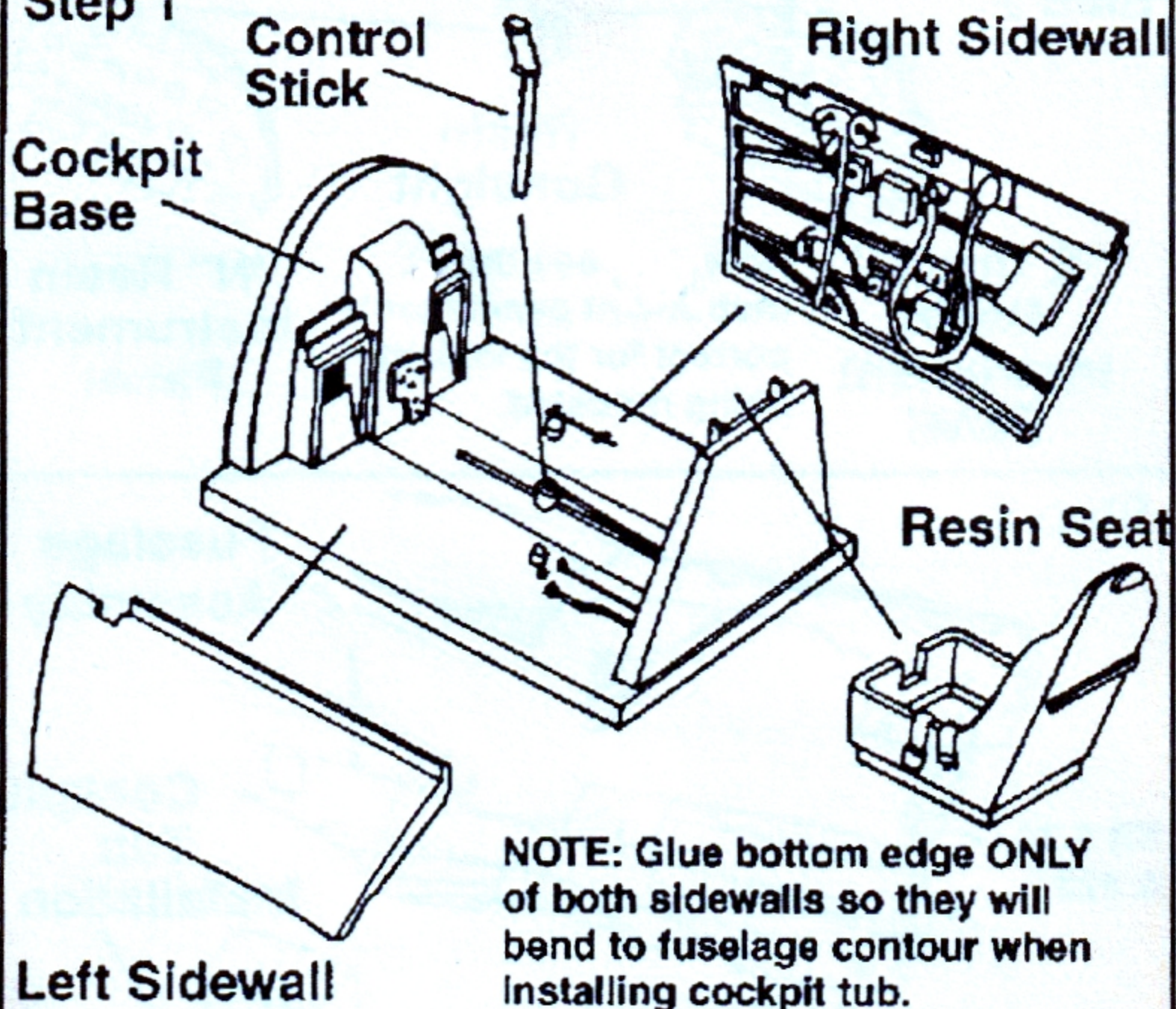

NOTE: Glue bottom edge ONLY of both sidewalls so they will bend to fuselage contour when installing cockpit tub.

PAINTING INSTRUCTIONS

FS 34151 (Interior Green) - Rudder Pedal Bulkhead, Left & Right Sidewalls, Floorboard, Seat and Fuselage Interior, Back Bulkhead.

FS 37038 (Flat Black) - Instrument Panel, Control Stick Handle, Gunsight, Oxygen Regulator, Throttle Quadrant, Radio Boxes, and Lower Control Panel.

FS 30117 (Leather Brown) - Cushion on Gunsight, Chaffing Pad on Lap Belt and Headrest Cushion.

FS 37925 (Flat White) - Shoulder Belts and Needles on Instrument Panel.

FS 34201 (Khaki Green) - Lap Belts.

FS 17178 (Silver) - Seat Belt Buckles and Rudder Pedals.

FS 34092 (Dark Green) - Oxygen Hose.

FS 17038 (Gloss Black) - Throttle Quadrant Handles.

Don't forget to include TRUE DETAIL Flattened and Bulged wheels to your kit for added realism.

Step 2

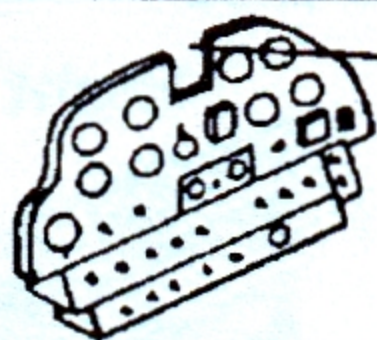

**"E thru M"
Resin
Instrument
Panel**

**Resin
Gunsight**

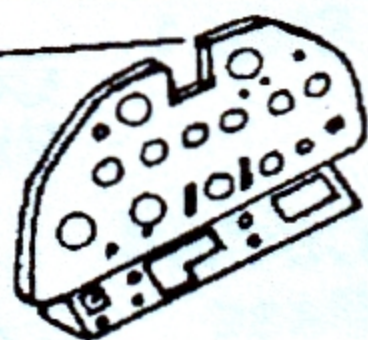

**"N" Resin
Instrument
Panel**

Note: Choose the instrument panel that is correct for the variant being modeled.

Step 3

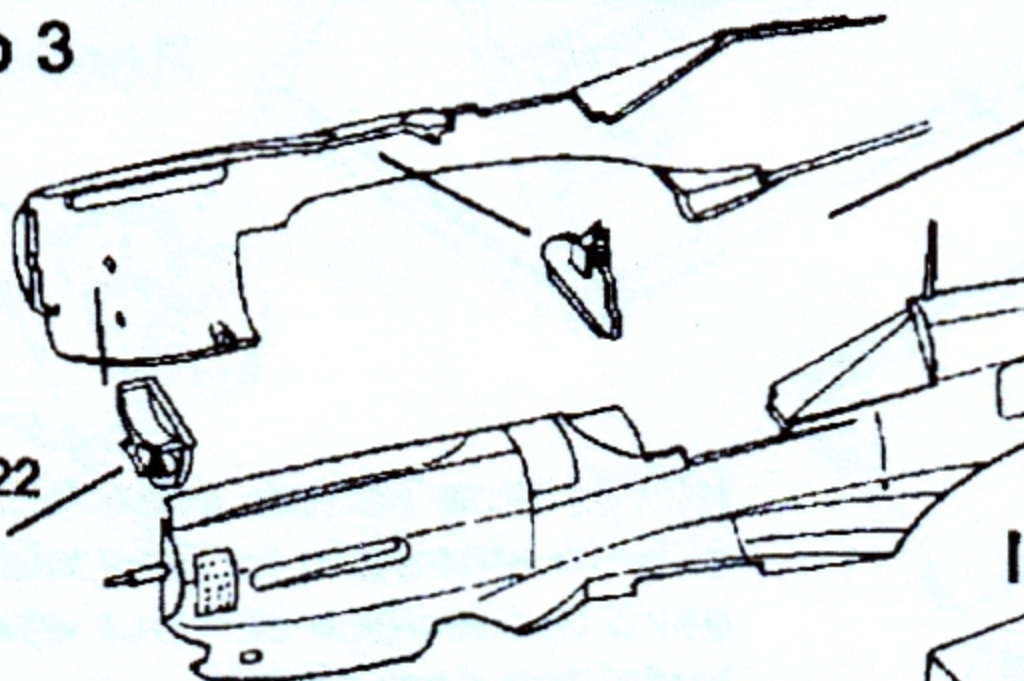

**Fuselage
Assembly**

**Cockpit
Tub
Installation**

**Kit # 22
& #23**

P-40E/N Warhawk Cockpit Assembly TD72458

(Recommended for 72nd scale HASEGAWA kits) These parts may be used with other P-40 kits with modifications.

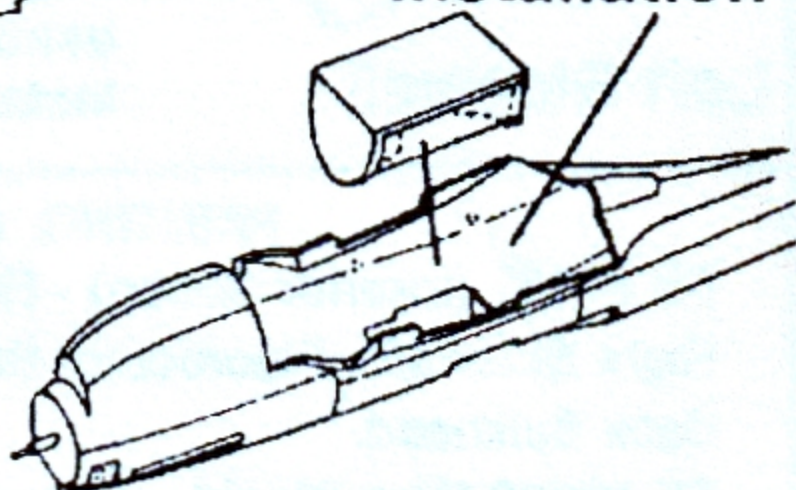

NOTE: These parts are resin parts, Super Glue or epoxy must be used for gluing.

P-40 E/M (Covered) TD72010

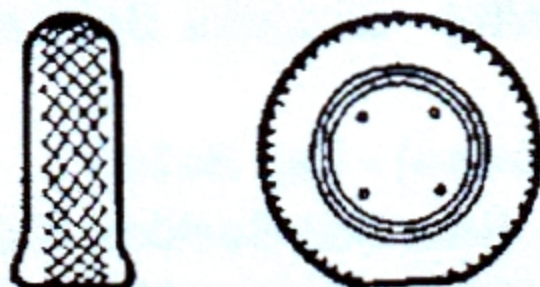

Congratulations on purchasing another fine **True Details** product. Our flattened and bulged wheels, shown above, will add a new degree of realism to your models. All of our wheels have accurate wheel/hub detail and tire tread pattern. They are bulged to give your model the realistic look of a loaded aircraft.