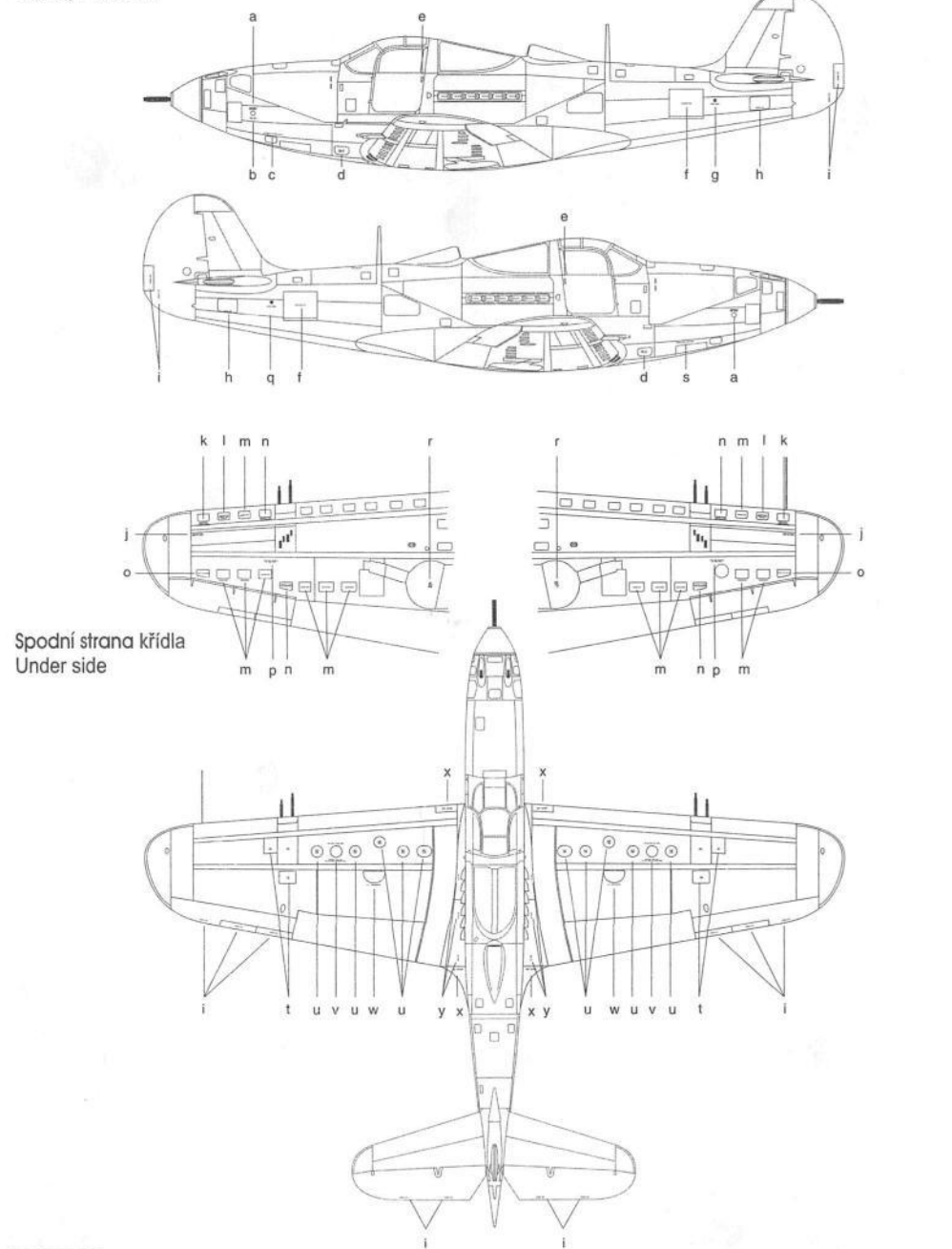

Popisky / Stencils

P-39 D/F/K Airacobra
Americký stíhací letoun / American WW II fighterP-39 D/F/K Airacobra
Americký stíhací letoun / American WW II fighter

The Bell P-39N was the first version of the Airacobra to be produced in large numbers, with a total of production run of 2,095 aircraft. All three were powered by the Allison V-1710-85 engine, and could carry 75 US gallon and 175 US gallon belly fuel tanks. All 500 P-39Ns used the 10ft 4in Aeroproducts propeller. The 900 P-39N-1s differed from the P-39N only in that they used the 11ft 7in Aeroproducts propeller. The P-39N-2 designation was given to 128 P-39N-1s converted to act as photographic recon-naissance aircraft. The N-3 designation was given to a further 35 aircraft converted in the same way. The 695 P-39N-5s were similar to the -1, but with a series of minor changes. The bullet-proof glass behind the pilot's head was replaced with armour plate, while the radio and oxygen systems were improved. 1113 of P-39N were exported to USSR.

92135

Stavební návod / Instruction

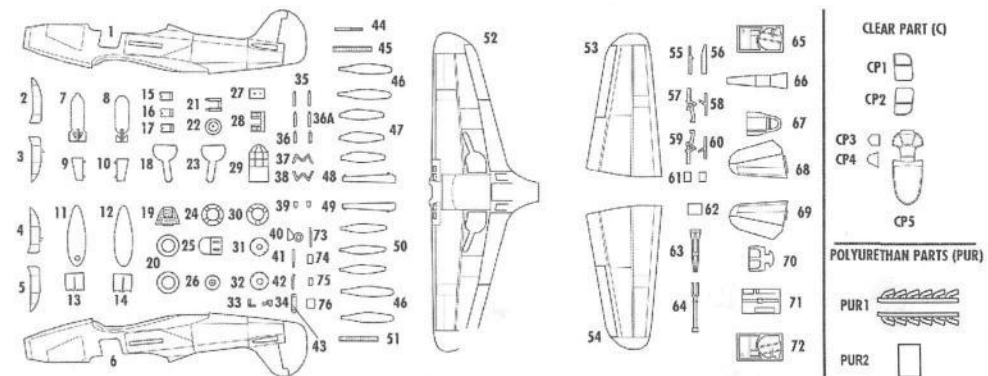

LEGEND

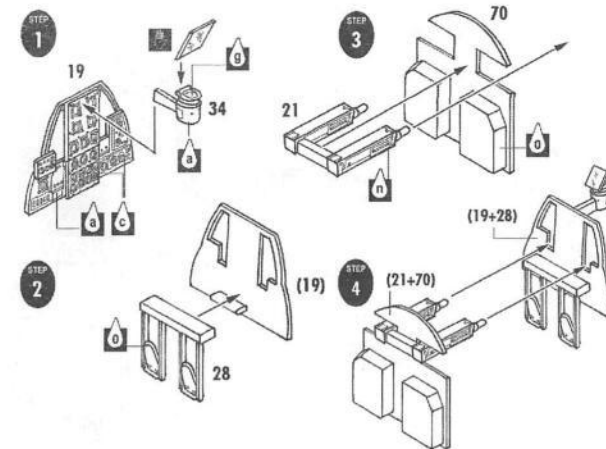

COLORS



