

NÁVOD / INSTRUCTION

SH32016 Mohawk Mk.IV

When the war had broke out both Great Britain and France begun to strengthen their air forces. This was achieved not only by increasing of the domestic aircraft production but also but purchasing machines from foreign countries, mainly from USA. Both British and French Purchase Committee ordered great quantity of aircraft from USA. When the France capitulated all aircraft were taken over by Great Britain. That's how the Curtiss Model 75 fighter got into RAF service. 200 aircraft of the original French order were taken over by RAF. They were named Mohawk and designated according to the particular versions to Mk.I-IV. Most of the RAF's Mohawks were of the Mk.IV version that was as the only one powered by nine-cylinder Wright R-1820 engine. These were during the Battle of Britain held as a provision aircraft. Later, when it was clear that these aircraft are not suitable for European theatre, they were transferred overseas. Seventy Mohawk Mk.IVs were handed over to SAAF that was not particularly satisfied with them and assigned them only to several combat units. Only SAAF 3rd Squadron participated in East African fights. Almost all of the rest RAF Mohawks were transferred to Far East Air Force (FEAF). These Mohawks were assigned to the 5th, 67th, 146th and 155th Squadrons and 151st OTU. Commonwealth pilots flew the Mohawks up to the December 1943. They mainly clashed with Imperial Japanese Army Air Force machines that were deployed to this area. The main opponents were highly maneuverable Ki-27 and Ki-43 fighters and Ki-21 and Ki-48 bombers. In heavy fights both successes and failures occurred. Mohawks were highly durable and therefore suitable for this theatre. Several collisions with Japanese aircraft occurred and Mohawks always won them.

Wingspan: 11.37m, Length: 8.79m, Max. Speed: 520kmh at 4600m, Service Ceiling: 9980m, Range: 1615km.

Velká Británie spolu s Francií začaly po vypuknutí druhé světové války horečně posilovat svá letectva. Dělo se tak nejen zvýšením domácí letecké produkce, ale také nákupem letadel v zahraničí, zejména v USA. Britská a francouzská nákupní komise společně objednaly v USA velké dodávky letadel. Po pádu Francie je převzala celé Velká Británie. Tak se do výzbroje RAF dostaly stíhačky Curtiss model 75. RAF převzalo 200 ks z původně francouzské objednávky, pojmenovalo je Mohawk a podle verze je označovalo Mk.I-IV. Většinu Mohawků RAF tvořily Mohawky Mk.IV, které byl jako jediné poháněny devítiválcovým motorem Wright R-1820. V době Bitvy o Británii byly drženy v záloze. Protože se ukázalo, že se nehodí pro evropské bojiště, byly přesunuty do zámoří. Sedmdesát Mohawků Mk.IV dostalo SAAF. Nebylo s nimi příliš spokojeno, přidělilo je několika bojovým squadronám, z nichž pouze 3. sq. SAAF s Mohawky Mk.IV zasáhla do bojů ve východní Africe. Prakticky všechny ostatní Mohawky Mk.IV RAF přesunulo k dálnévýchodnímu letectvu FEAF (Far East Air Force). Mohawky byly zařazeny k 5., 67., 146. a 155. squadroně a k 151. OTU. Piloti Commonwealthu na Mohawcích bojovali až do prosince 1943. Utkávali se s letouny japonského armádního letectva nasazenými v této oblasti. Hlavními protivníky byly velmi obratné stíhačky Ki-27 a Ki-43 a bombardovací Ki-21 a Ki-48. Těžké boje byly provázány střídavými úspěchy a neúspěchy. Mohawky si na tomto bojišti nevedly špatně. Navíc byly velmi odolné. Z několika případů srážek s japonskými protivníky vyšel Mohawk vždy jako vítěz.

Rozpětí: 11,37 m, délka: 8,79 m, max. rychlost: 520 km/h v 4 600 m, dostup: 9 980 m, dolet 1 615 km.

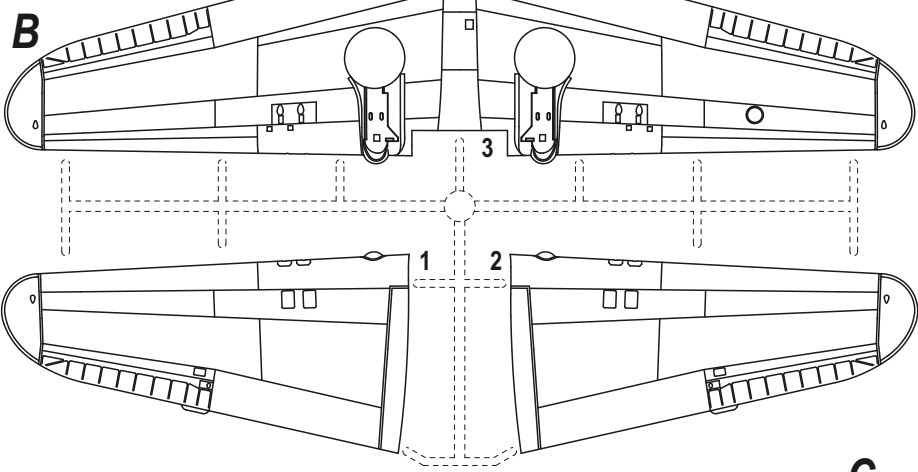
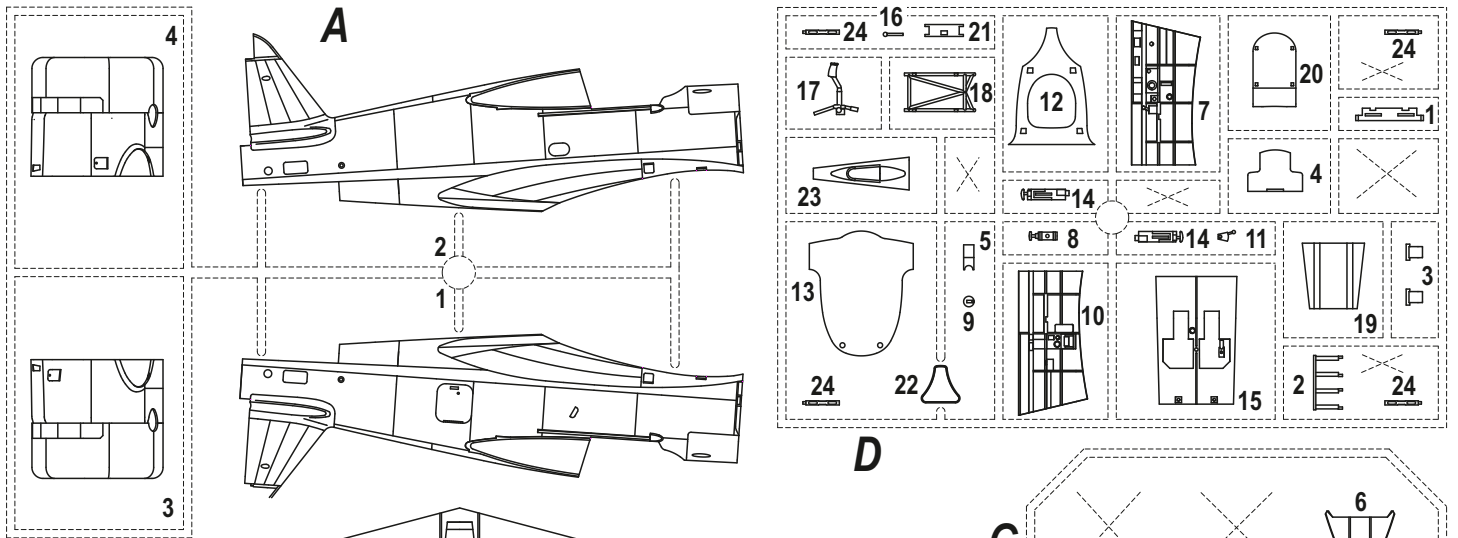

POLYURETHAN PARTS (H)

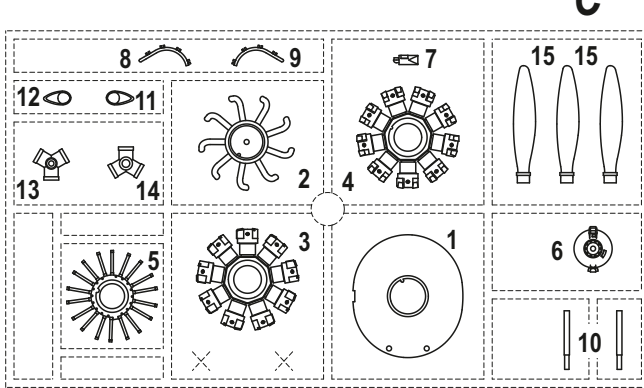
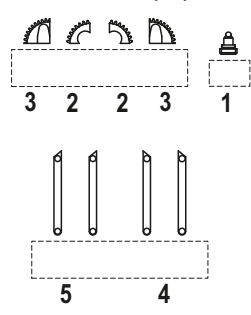

H2 / C2	Gloss Black / Lesklá černá
H3 / C3	Gloss Red / Lesklá červená
H4 / C4	Gloss Yellow / Lesklá žlutá
H8 / C8	Silver / Stříbrná
H12 / C33	Matt Black / Matná černá
H18 / C28	Steel / Ocel
H28 / C78	Metal Black / Kovová černá
H53 / C13	Neutral Grey / Šedá
H76 / C61	Burnt Iron / Opálený kov
H77 / C137	Tire Black / Černá na pneumatiky
H90 / C47	Clear Red / Červený lak
H93 / C50	Clear Blue / Modrý lak
C352	Interior Yellow / Interiérová žlutá
C361	Dark Green / Tmavá zelená
C362	Ocean Grey / Oceánská šedá
C363	Medium Sea Grey / Střední mořská šedá
C368	Sky / Nebeská



FILM PARTS (FP)



Možnost volby
Optional
Nach belieben
Option

Ohnout
Bend
Biegen
Courber

Oddělit
Cut with knife
Mit Messer schneiden
Couper au couteau

Lepidlo na kov
Glue for metal
Metallkleber
Colle a metal

PHOTOETCHED PARTS

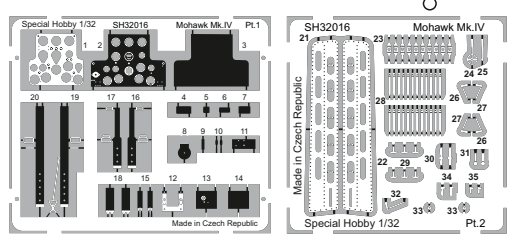

1

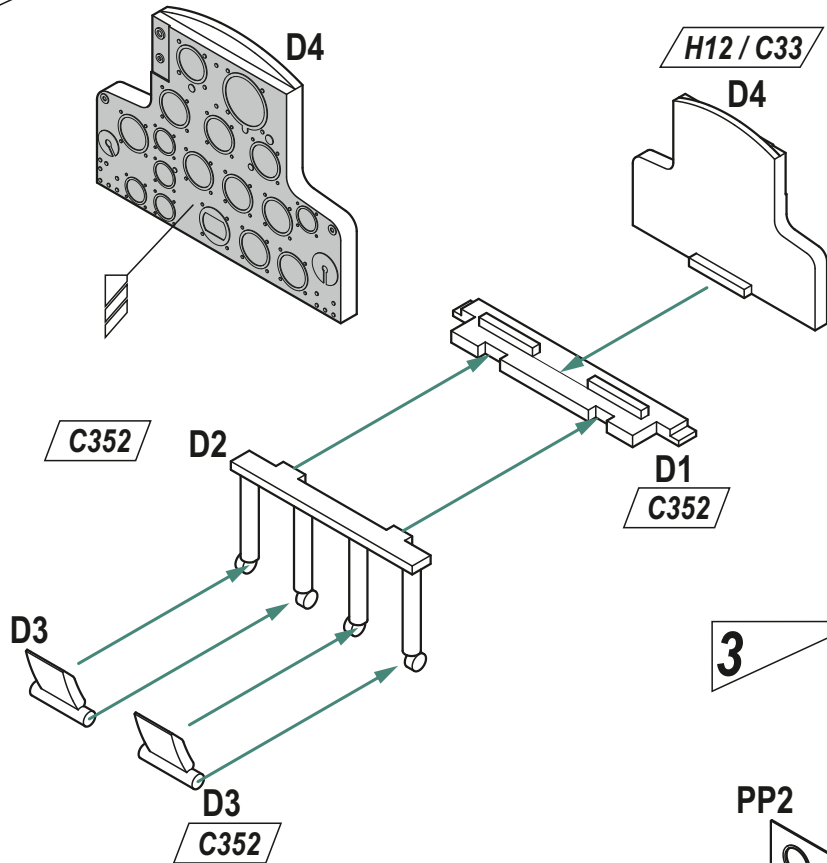

2

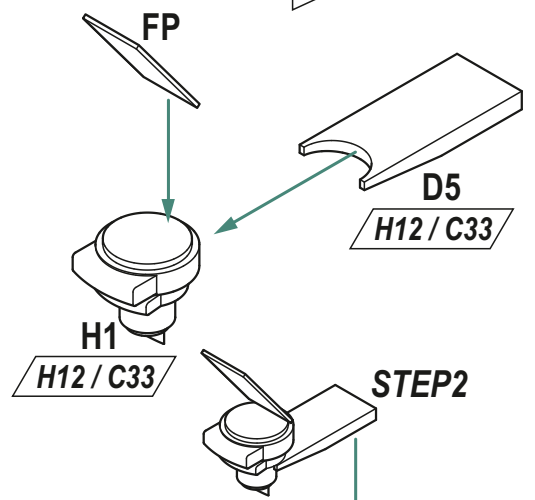

3

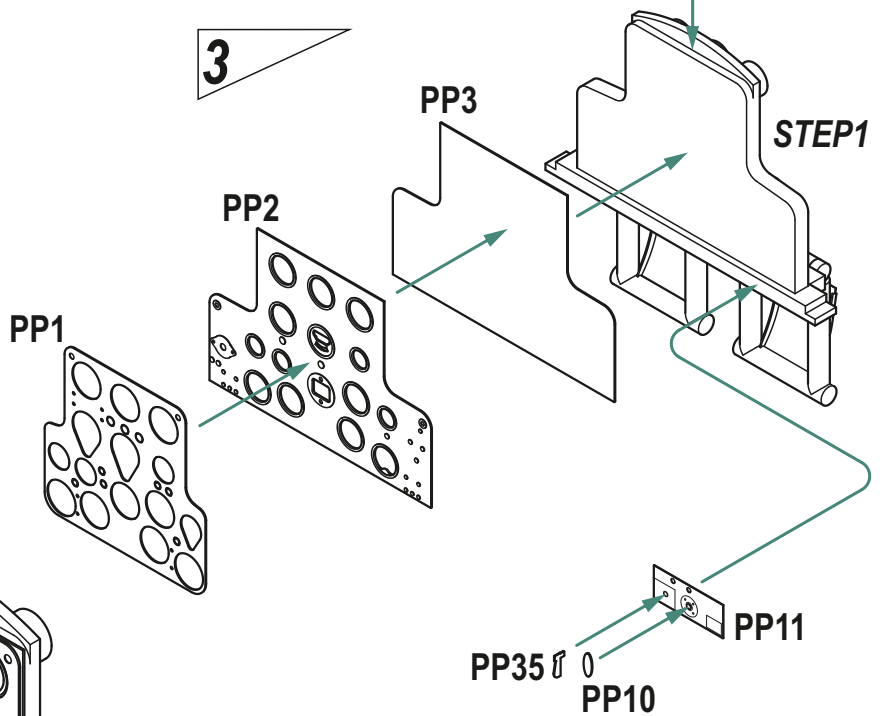

4

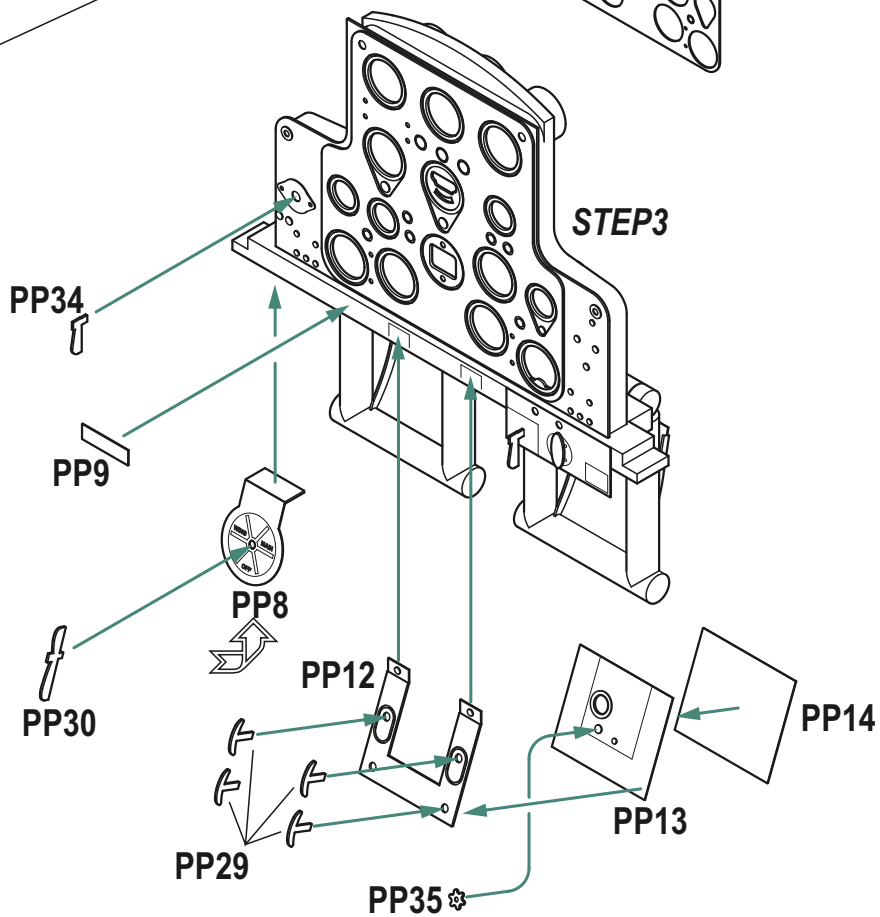

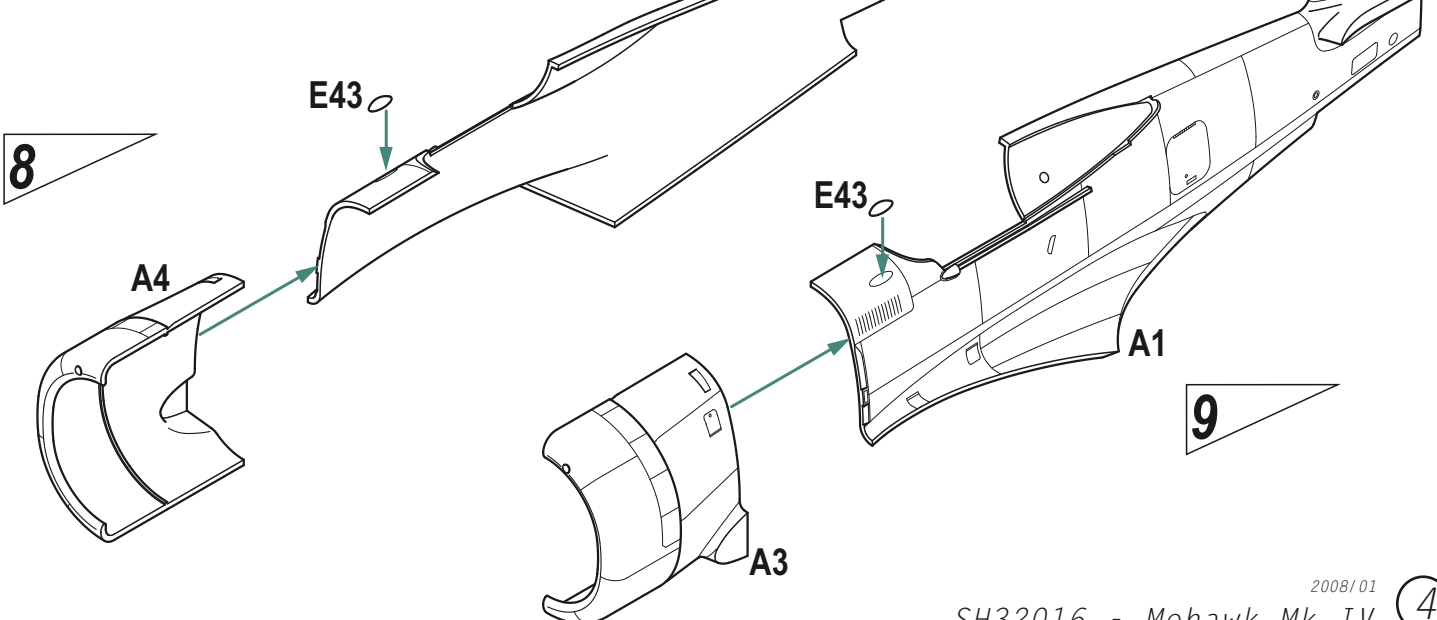
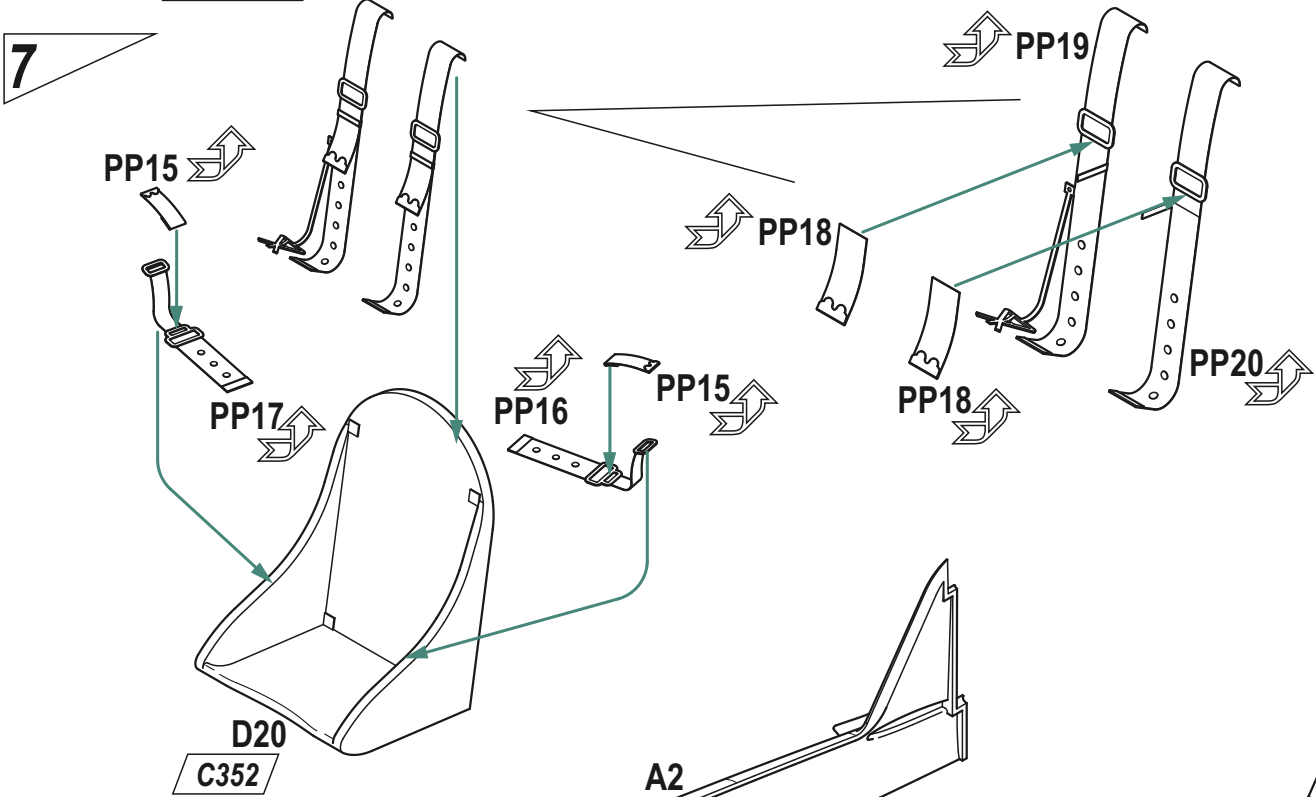
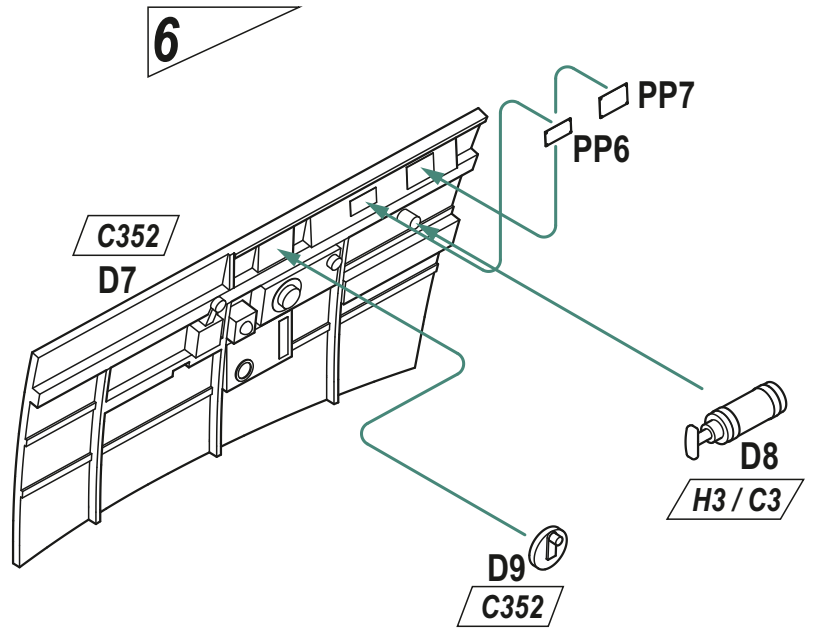
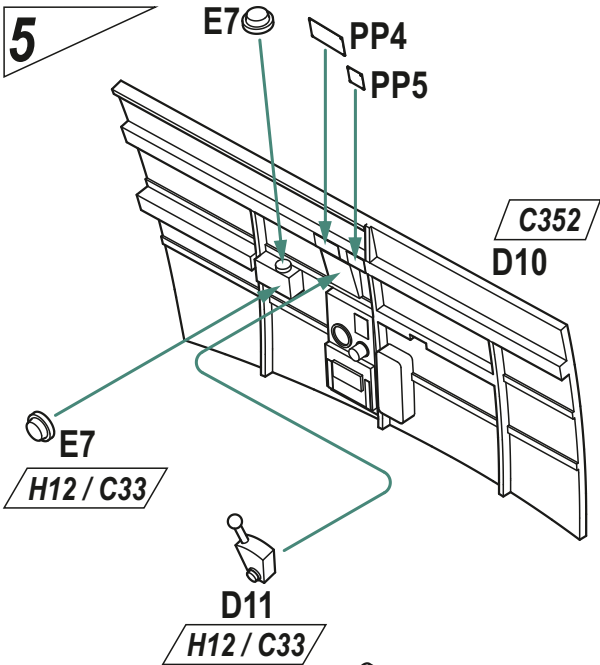

10

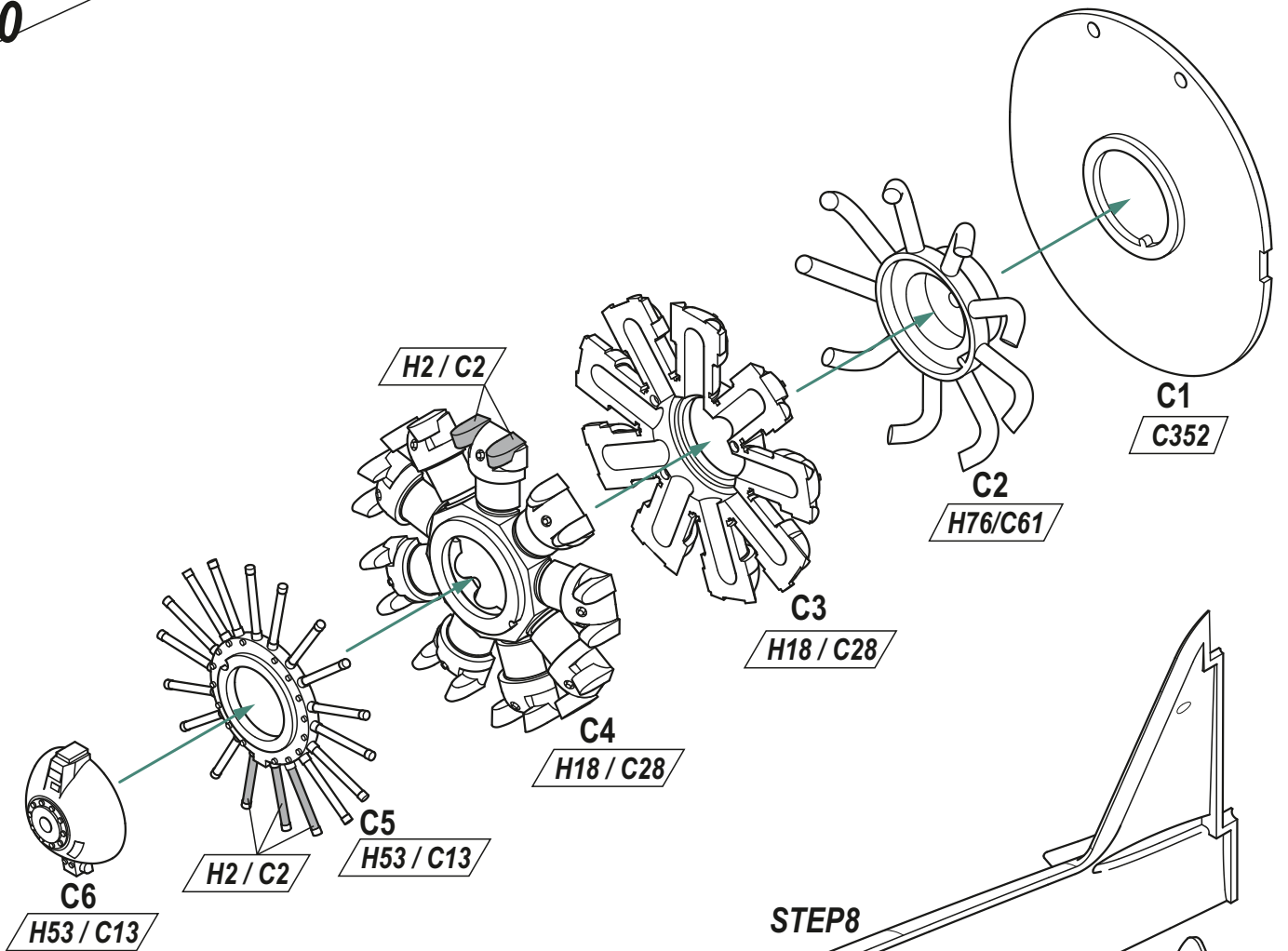

11

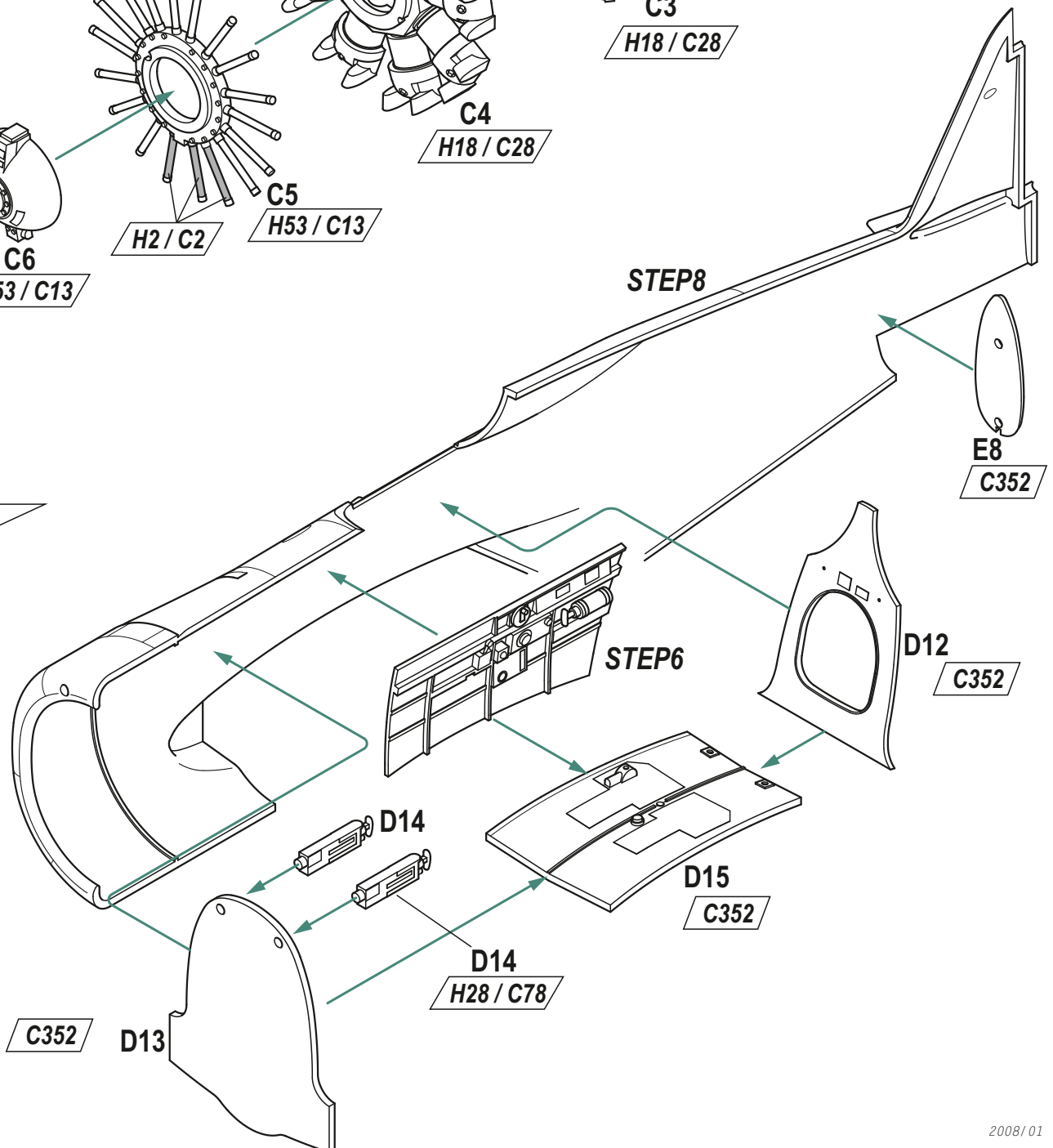

12

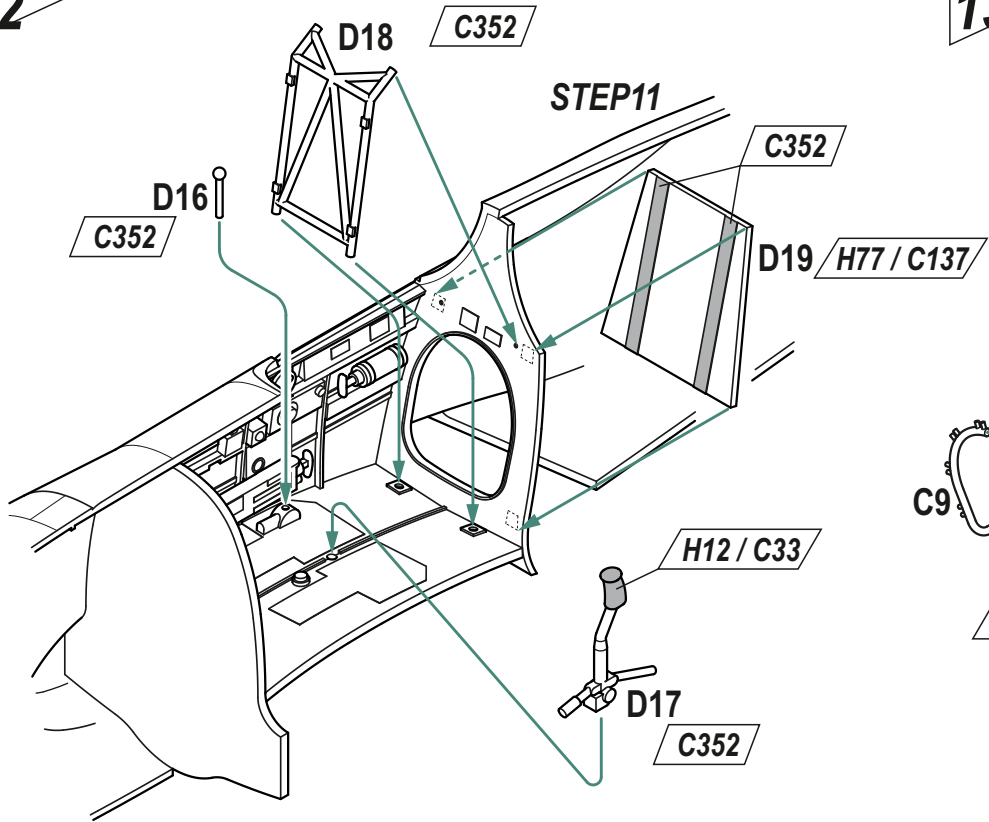

13

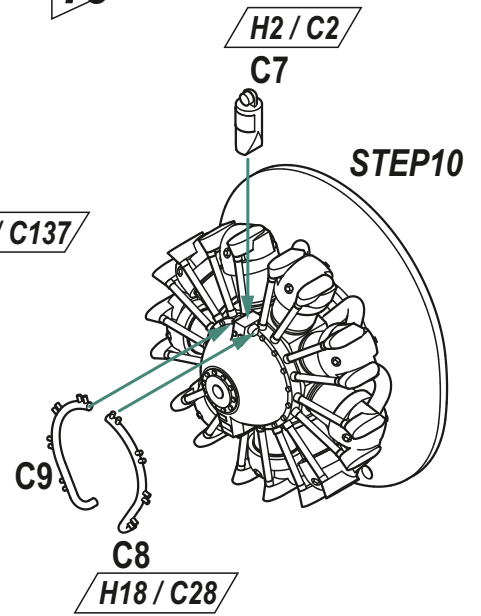

14

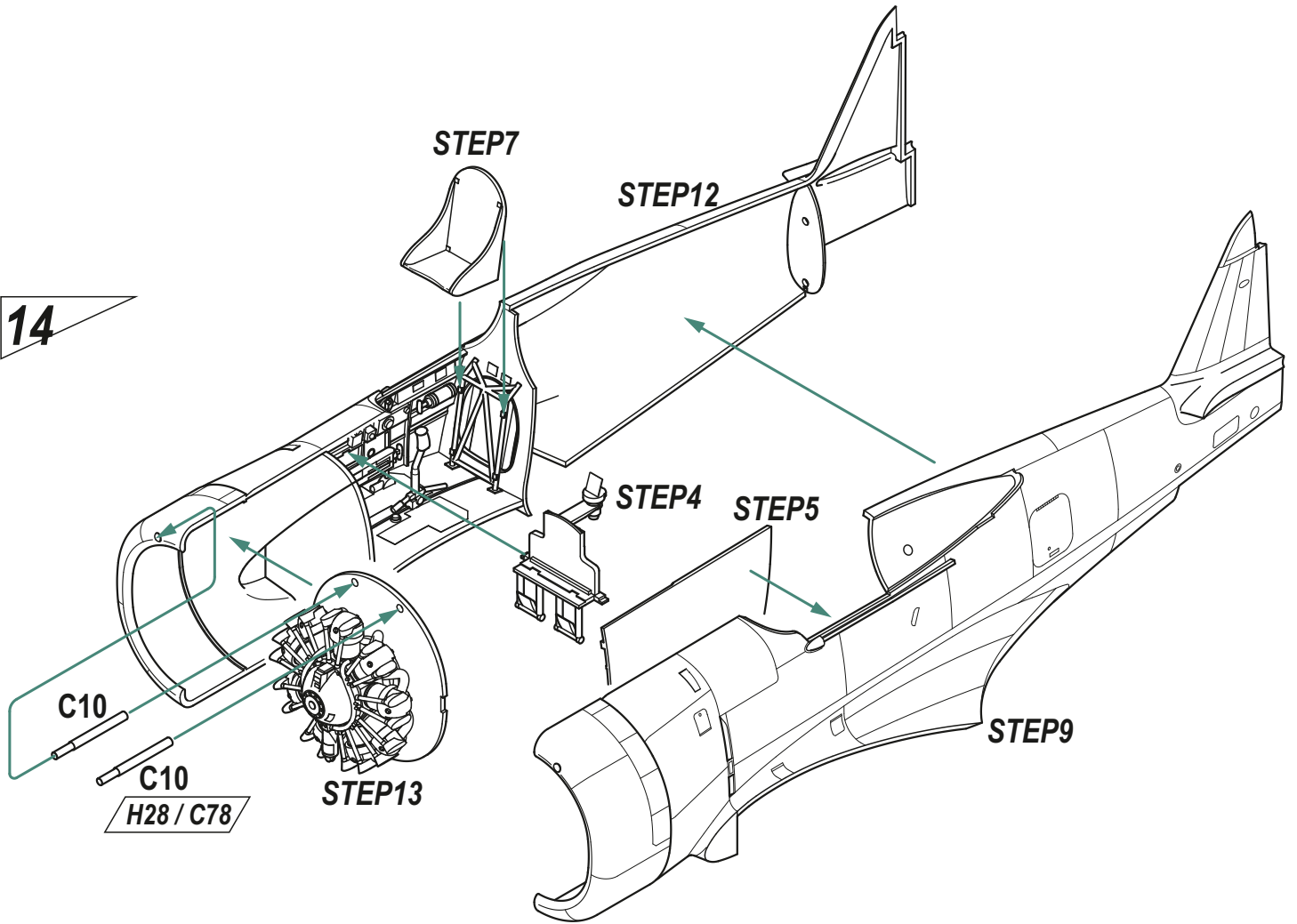

15

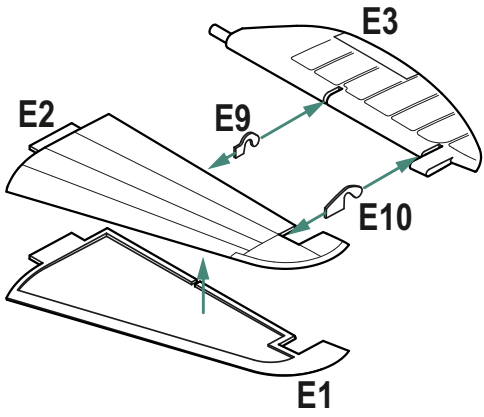

16

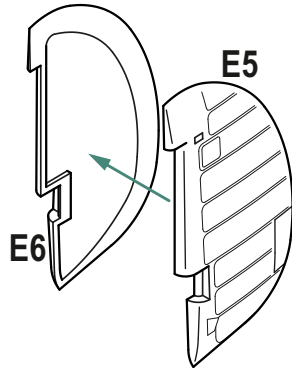

17

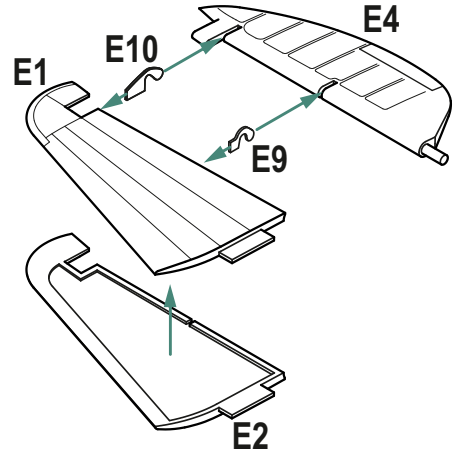

18

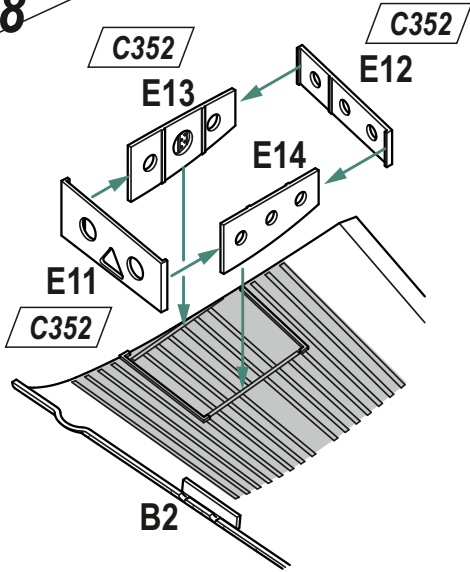

19

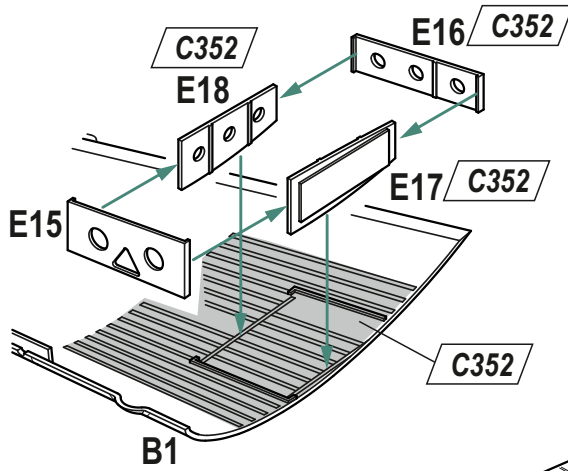

20

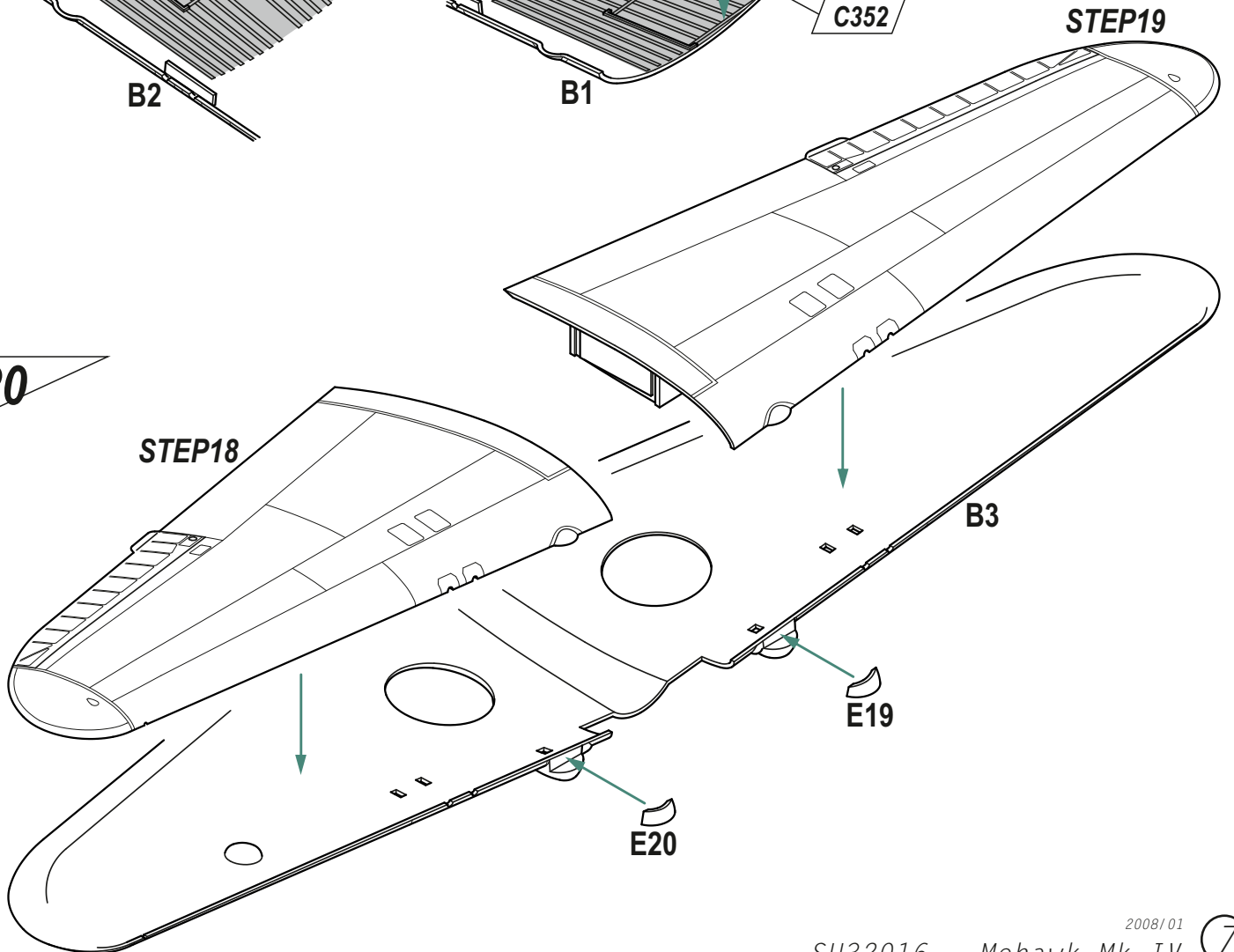

21

STEP17

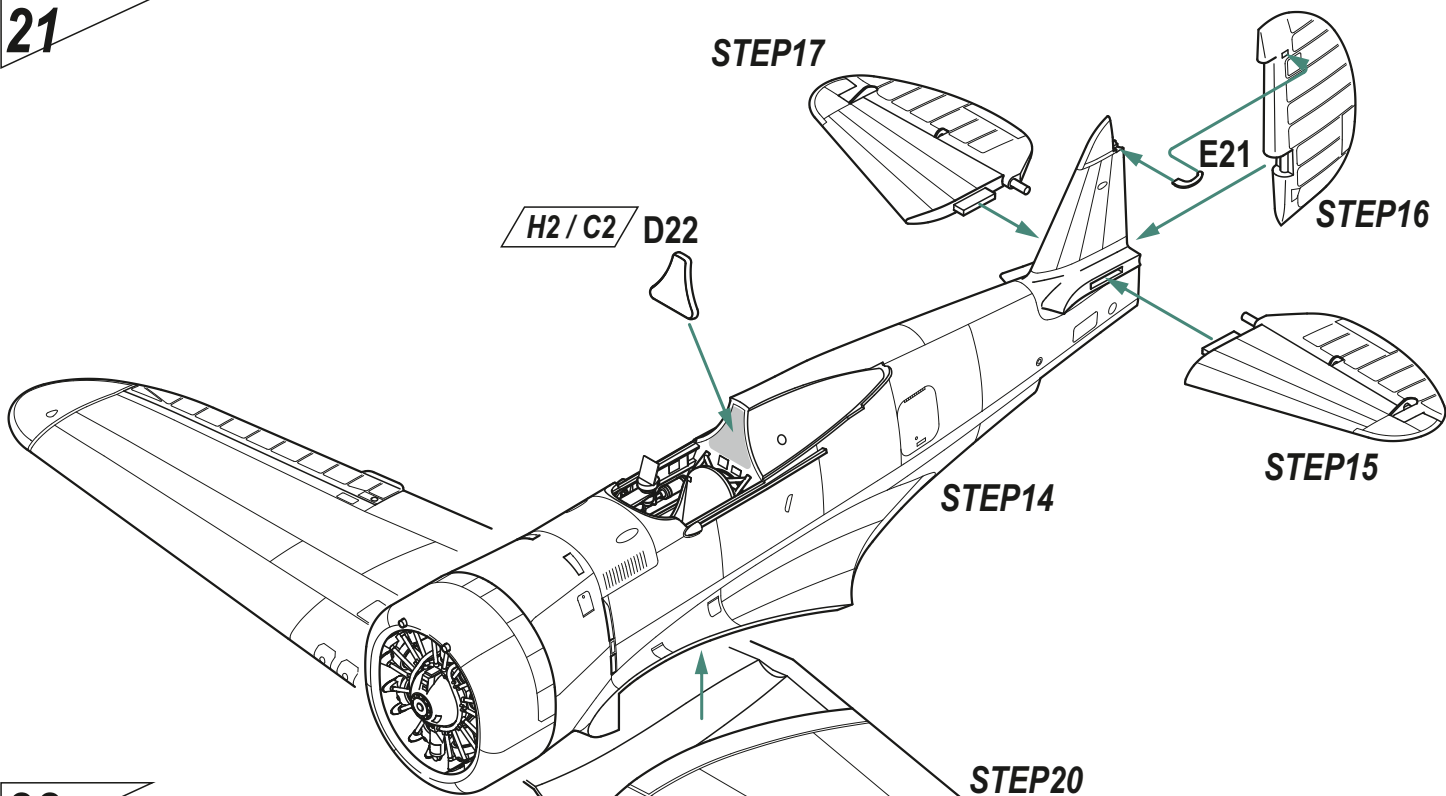

22

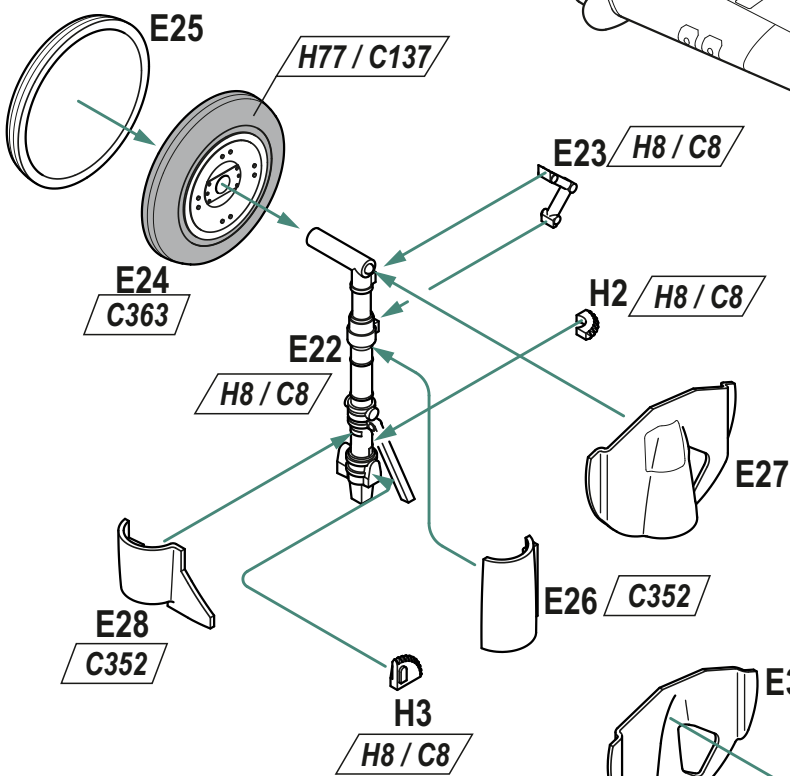

23

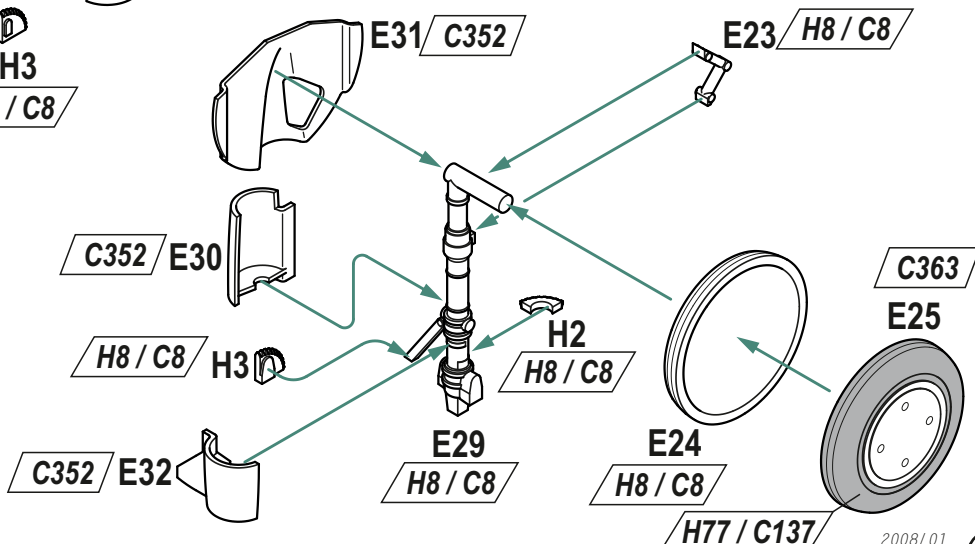

24

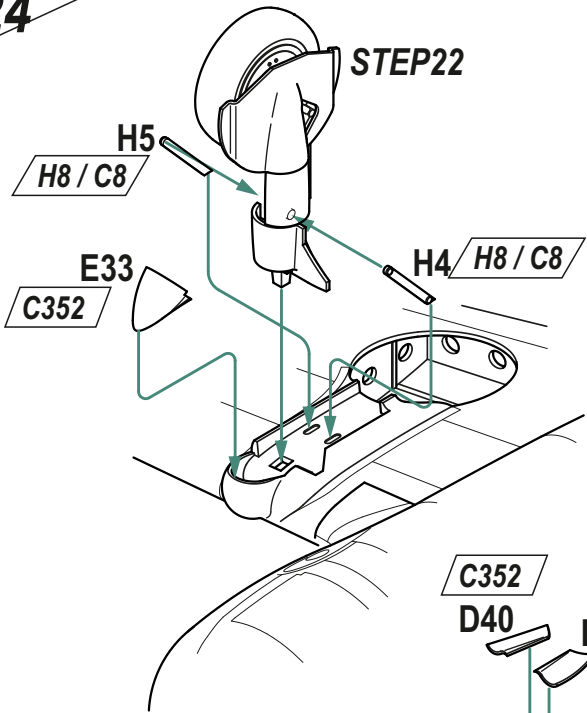

25

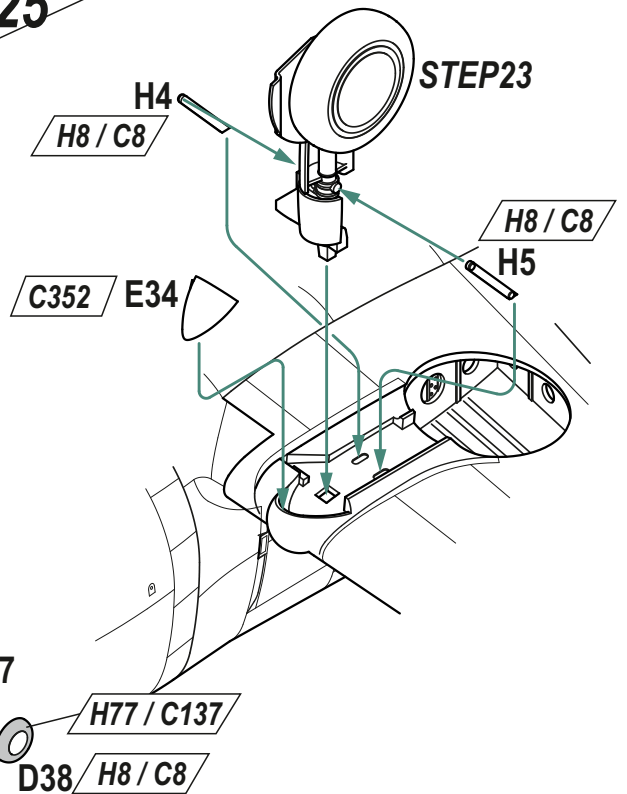

26

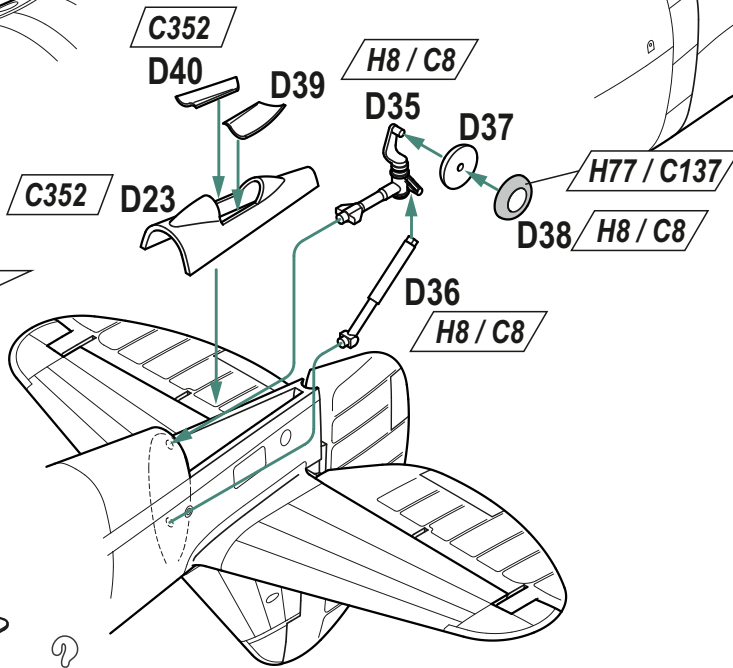

27

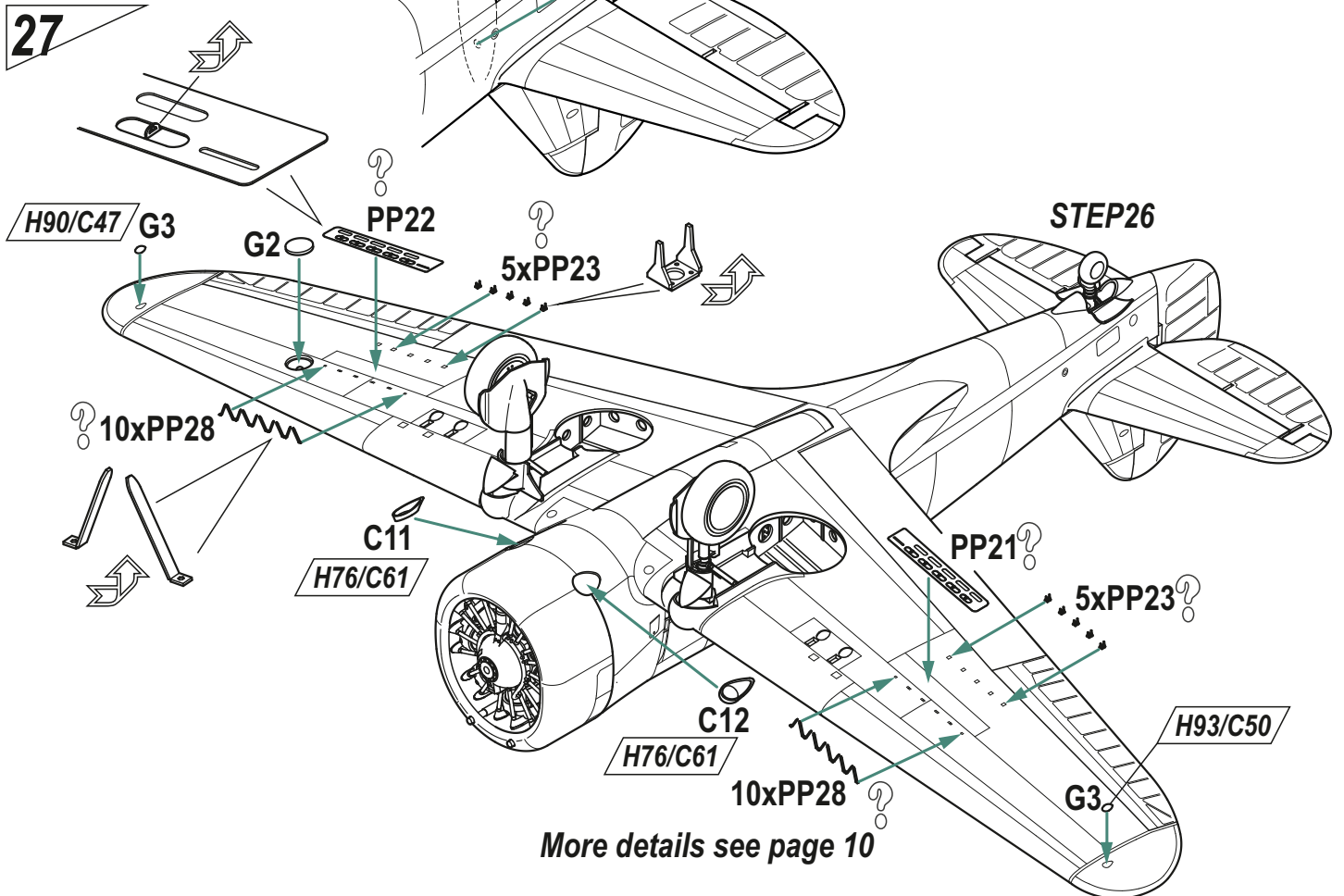

More details see page 10

INFO VIEW FOR STEP27

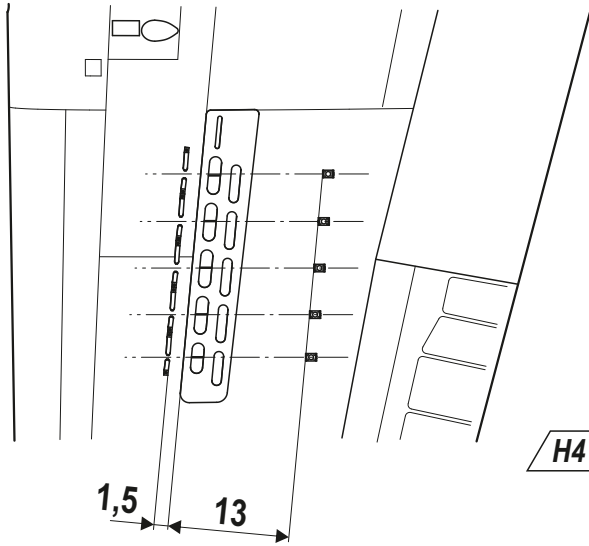

28

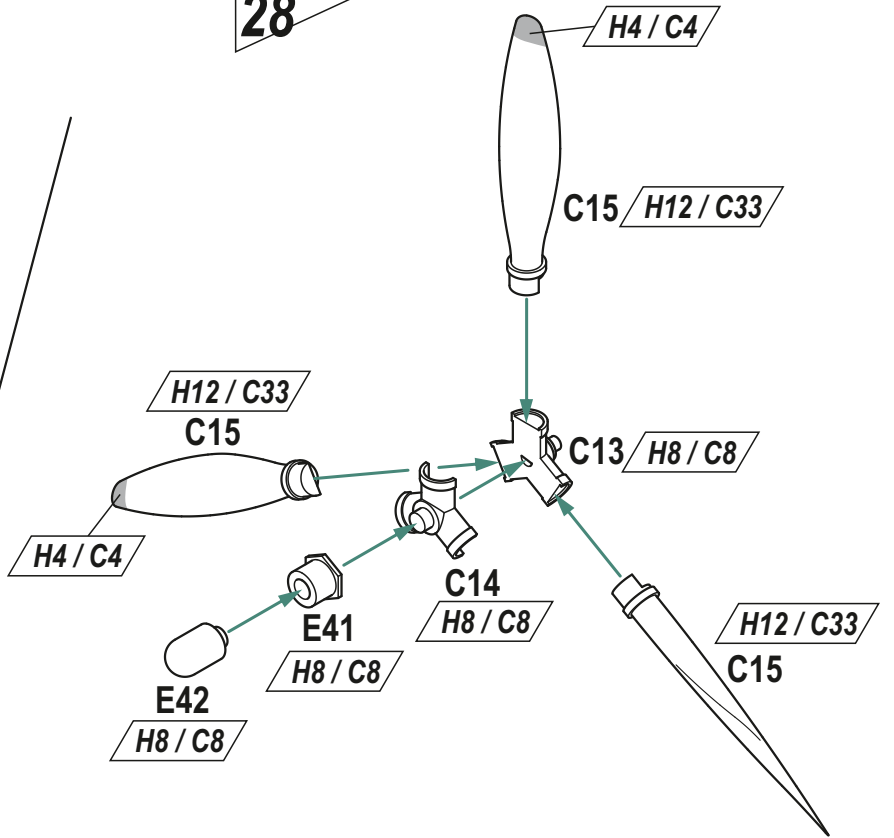

29

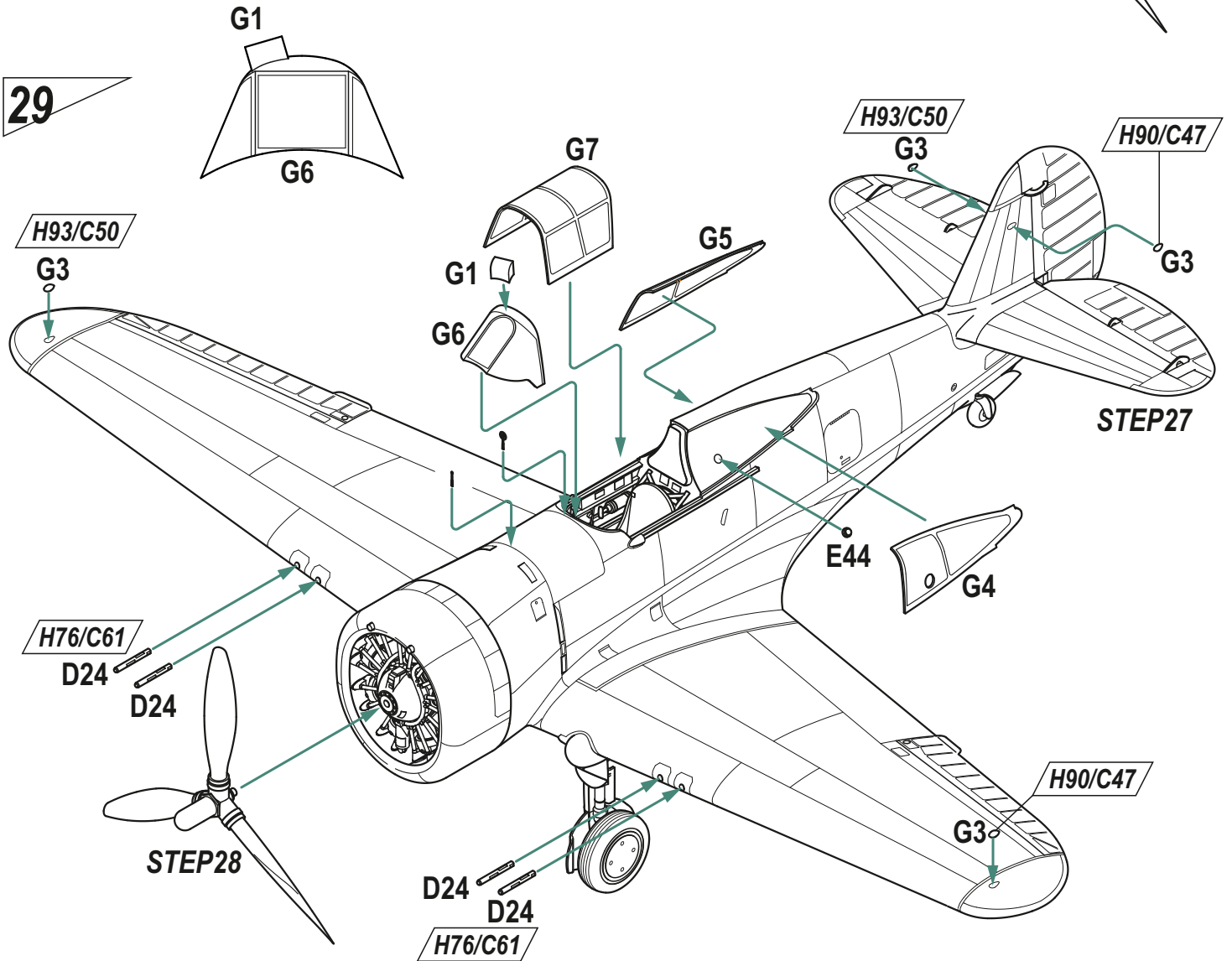

Mohawk Mk.IV BS798/B, 155. sq. RAF, Argatala, srpen 1943.
 Nestandardní znaky vznikly zatřením červených středů znaků.

Mohawk Mk.IV BS798/B, RAF 155th Squadron, Argatala, August 1943. The non-standard national insignias were created by over painting of the red centers.

CAM. A

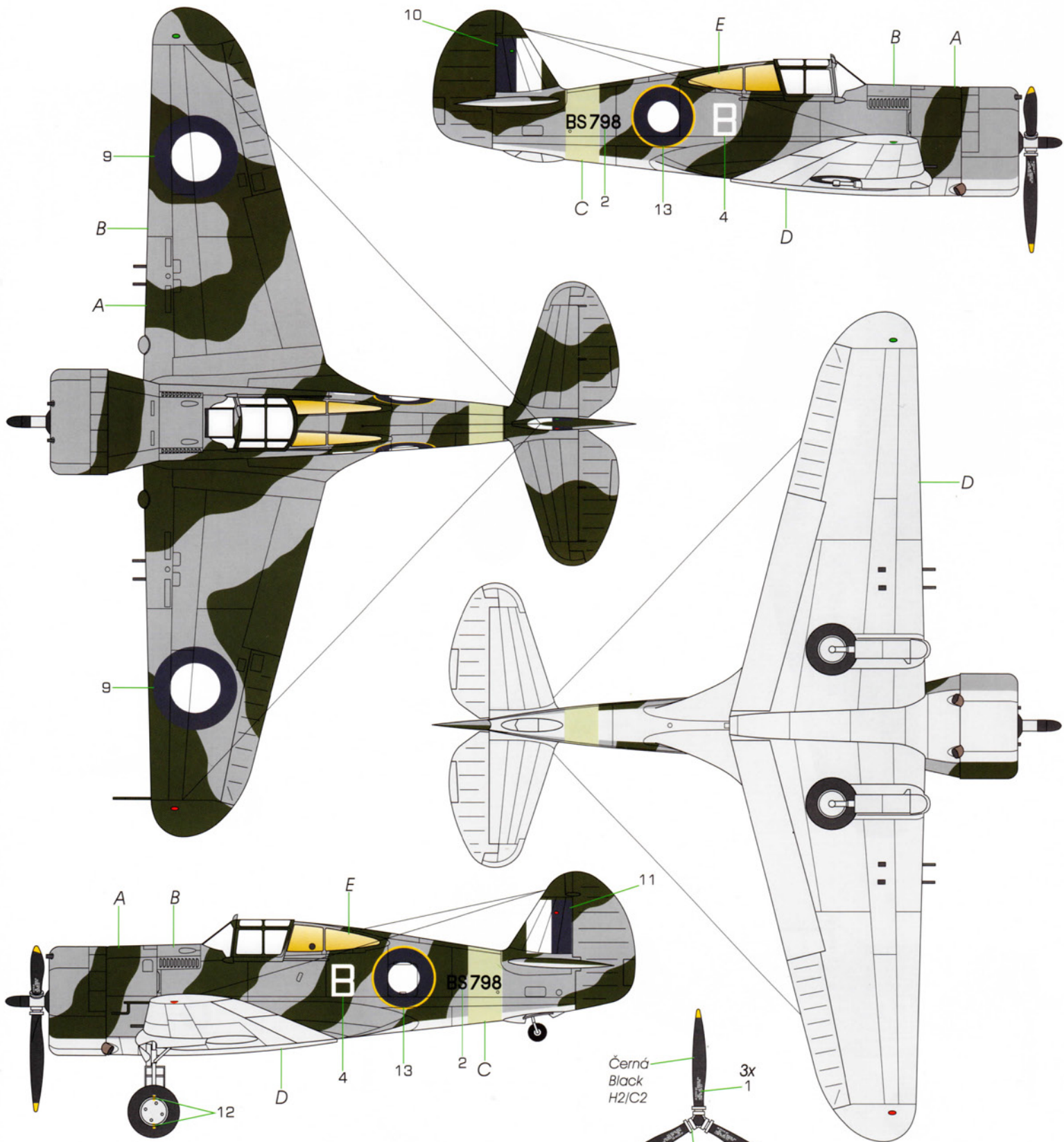

E Interiérová žlutá
 Chromate Yellow Primer
 C352

Žlutá
 Yellow
 H4/C4

Stříbrná
 Silver
 H8/C8

A Tmavá zelená
 Dark Green
 C361
 X 001
 XA 1001

B Oceánská šedá
 Ocean Grey
 C362
 X 006
 XA 1006

C Nebeská
 Sky
 C368
 X 007
 XA 1007

D Střední mořská šedá
 Medium Sea Grey
 C363
 X 003
 XA 1003



Mohawk Mk.IV BJ563/A pojmenovaný „Joe Soap II“ pilotoval F/O Tim Meyers, 155. sq. RAF, Imphal, konec roku 1943. U tohoto letounu není známo sériové číslo, číslo BJ563 je fiktivní. Znaky byly již definitivního provedení pro oblast SEAC.

Mohawk Mk.IV BJ563/A, named „Joe Soap II“ and piloted by F/O Tim Meyers, RAF 155th Squadron, end of 1943. The exact serial number is unknown, the BJ563 is fictive. The national insignias are of the final SEAC theatre design.

CAM. B

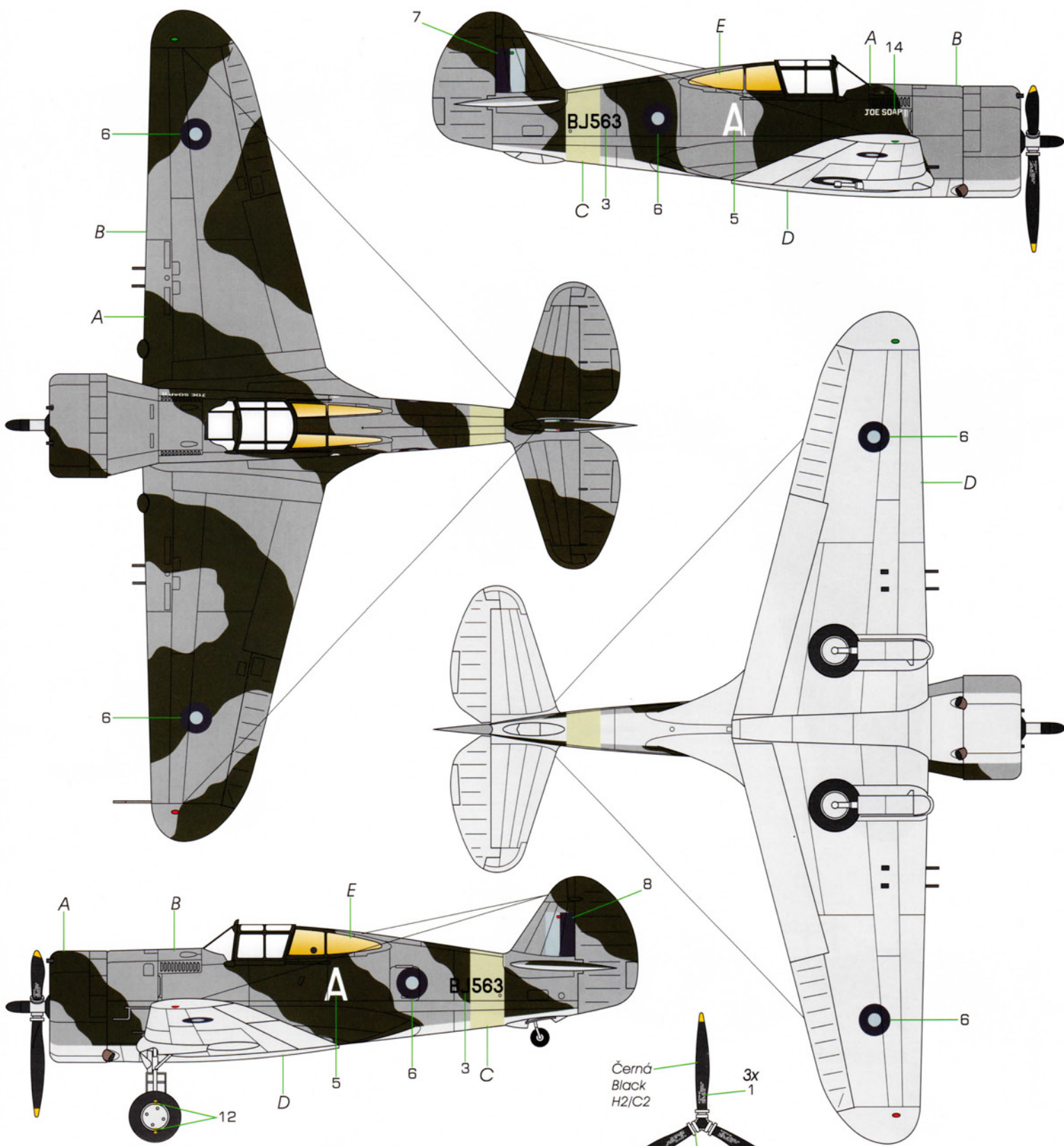

- | | | | |
|---|--|---|---|
| <p>A</p> <p>Tmavá zelená
Dark Green
C361
X 001
XA 1001</p> | <p>B</p> <p>Oceánská šedá
Ocean Grey
C362
X 006
XA 1006</p> | <p>C</p> <p>Nebeská
Sky
C368
X 007
XA 1007</p> | <p>D</p> <p>Střední mořská šedá
Medium Sea Grey
C363
X 003
XA 1003</p> |
|---|--|---|---|
-
- | | | | |
|--|-----------------------------------|----------------------------------|-------------------------------------|
| <p>E</p> <p>Interiérová žlutá
Chromate Yellow Primer
C352</p> | <p>Žlutá
Yellow
H4/C4</p> | <p>Černá
Black
H2/C2</p> | <p>Sříbrná
Silver
H8/C8</p> |
|--|-----------------------------------|----------------------------------|-------------------------------------|

