

SOVA-M
SVM-72003

**Northrop
Grumman
Firebird**



UNASSEMBLED PLASTIC MODEL KITS

SCALE: 1/72

DECALS

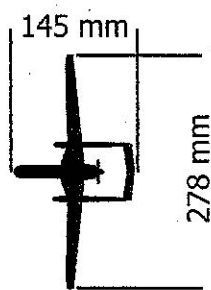

72 part

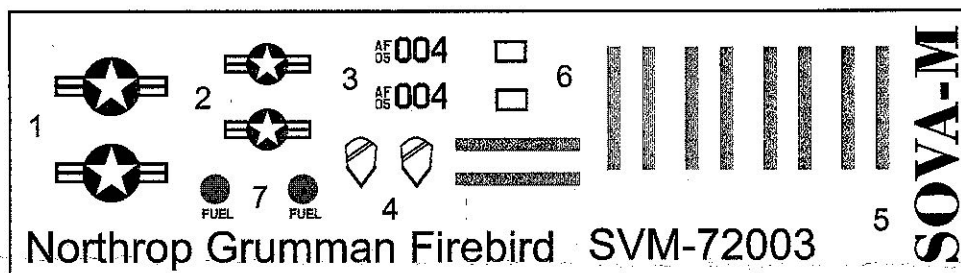

Northrop Grumman Firebird SVM-72003

ONE VERSION OF COLOURING

The Northrop Grumman Firebird is an intelligence gathering aircraft designed by Northrop Grumman's Scaled Composites design shop which can be flown remotely or by a pilot. At Scaled, it is known as the Model 355. It was unveiled on May 9, 2011. It was first flown in February 2010 and is considered to be an optionally piloted vehicle (OPV). The idea of building an aircraft capable of being flown with or without a pilot was first floated 9 February 2009 by Rick Crooks, when he contacted Scaled Composites about the possibility of building such an aircraft. Scaled agreed, and on 9 February 2010 the aircraft made its first flight. In October 2010, the aircraft demonstrated its capabilities of collecting information from multiple sources simultaneously for the first time when it made a demonstration flight in Sacramento, California, for defense officials. On 9 May 2011 the aircraft was publicly unveiled for the first time, and between 23 May and 3 June 2011, it participated in the 2011 Empire Challenge exercise, where it displayed its ability to carry multiple payloads and switch them out rapidly. If it enters production, construction of the Firebird is planned to move to factories in Palmdale, California or Moss Point, Mississippi, rather than the Scaled Composites facility in Mojave, California.

The model is executed on technology short run and is intended only for experienced modelers.

Word-wide distributor for Sova-M kits:
ModelSvit Balkans Ltd. 4003 Plovdiv,
Bulgaria 9, zk Maritza Gardens.

Tel. +359 32 397 069, E-Mail: modelsvitbalkans@gmail.com

MADE IN UKRAINE

PAINTS

- | | |
|-------------------------------------|---------------------------------------|
| A HUMBROL 22
WHITE | B HUMBROL 33
BLACK |
| C HUMBROL 11
SILVER | D HUMBROL 145
MEDIUM GREY |
| E HUMBROL 27004
GUN METAL | F HUMBROL 127
US GHOST GREY |
| G HUMBROL 155
OLIVE DRAB | |

SYMBOLS

- | | | |
|-------------------------------------|----------------------|---------------|
| 1 STAGES OF
ASSEMBLY | TO PAINT | TO BEND |
| 1 NUMBER
PARTS | GLUE | SCRATCH BUILT |
| APPLY
DECALS | DON'T GLUE | OPEN HOLE |
| x2 QUANTITY OF
OPERATIONS | НА ВИБІР
OPTIONAL | CAT OUT |

SET OF THE PARTS



PARTS NOT FOR USE 

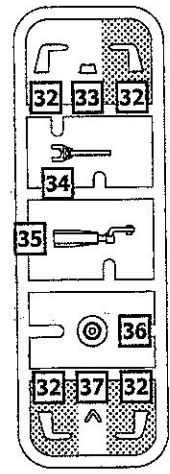
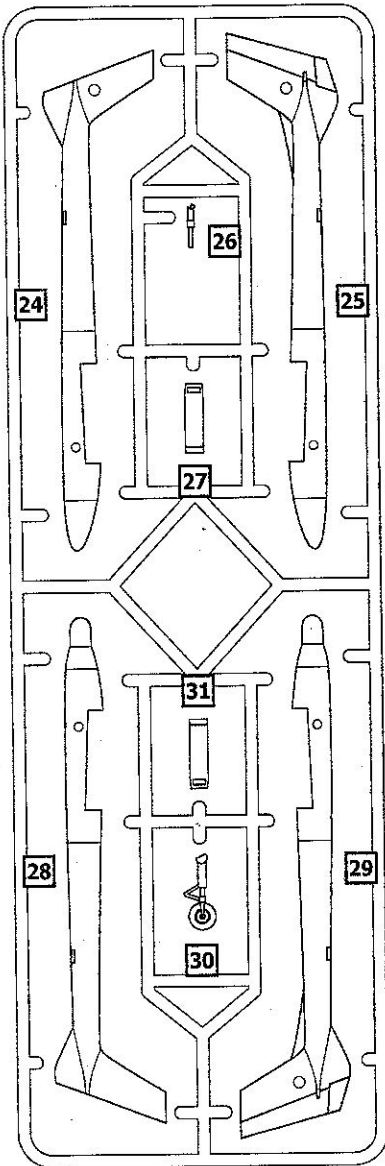
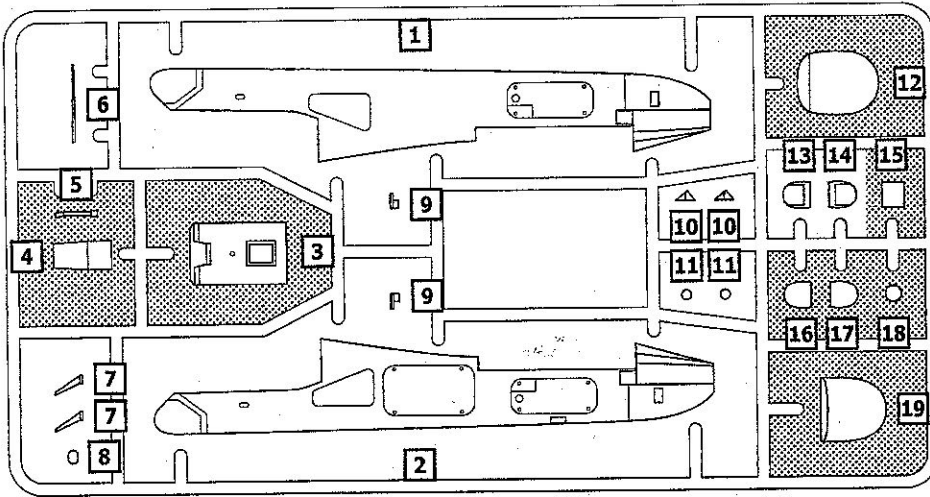

x2

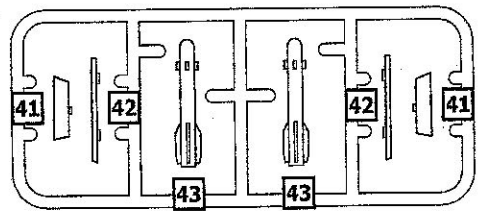
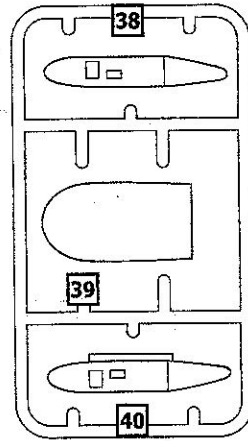

x2

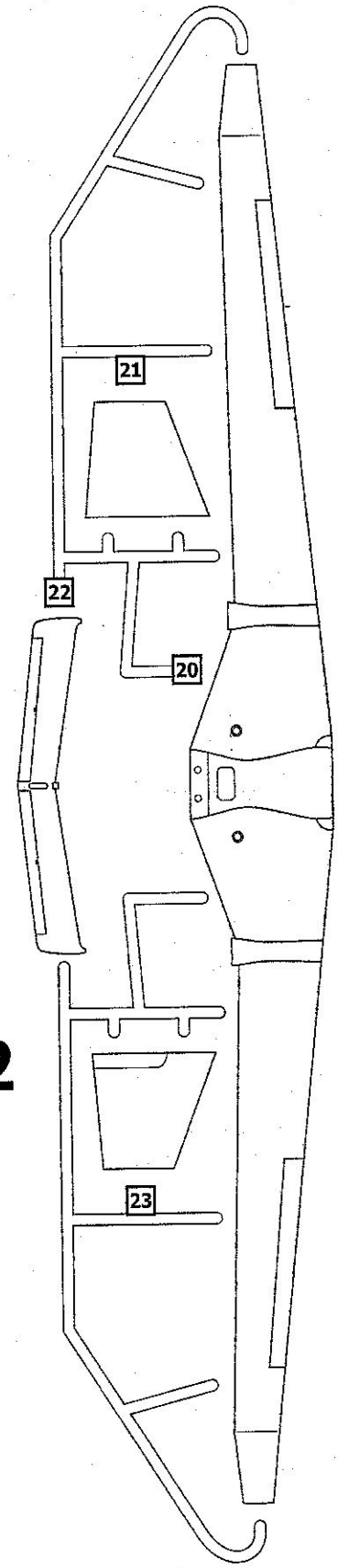
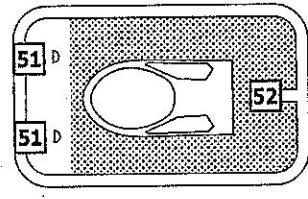
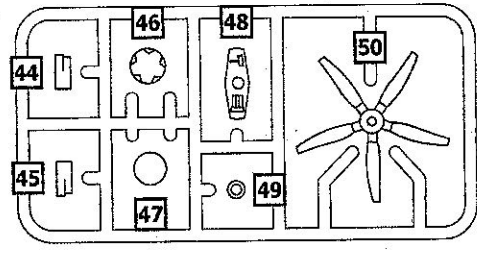

- 1**
- 46
- 47
- 48
- 49
- 50

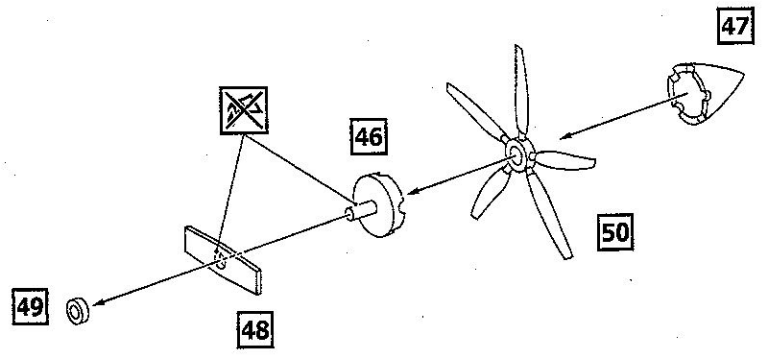

- 2**
- 1
- 1
- 2
- 39

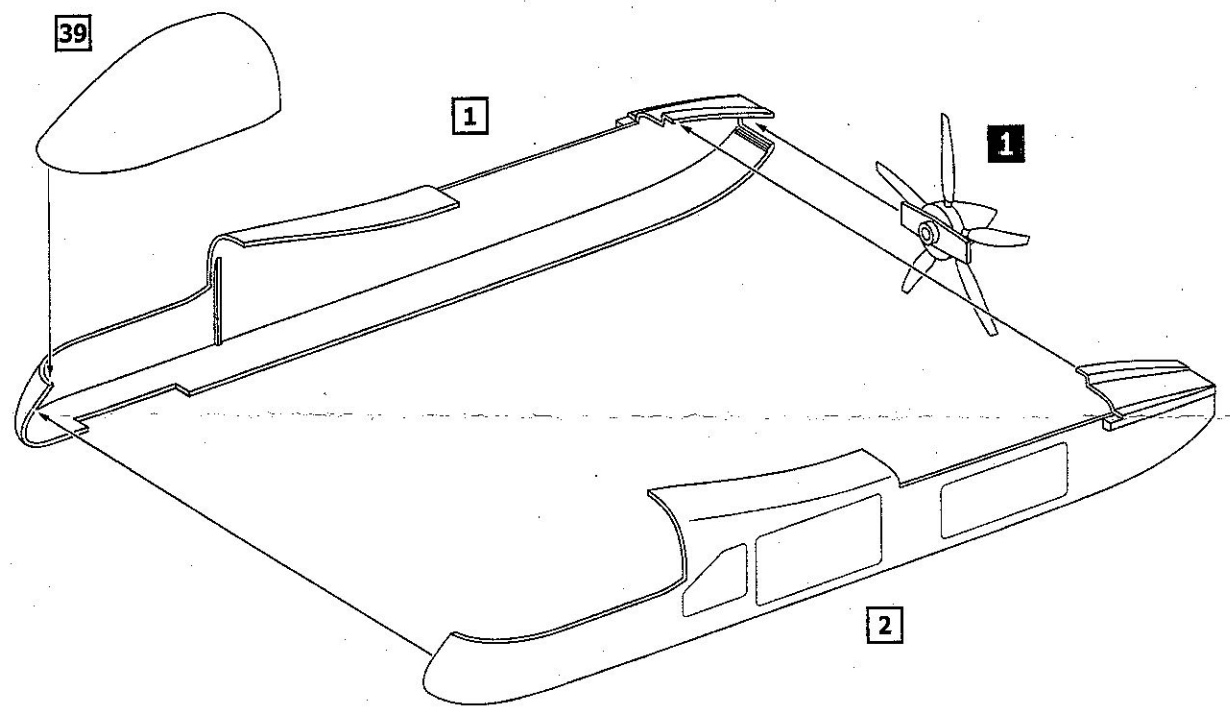

- 3**
- 24
- 25
- 27

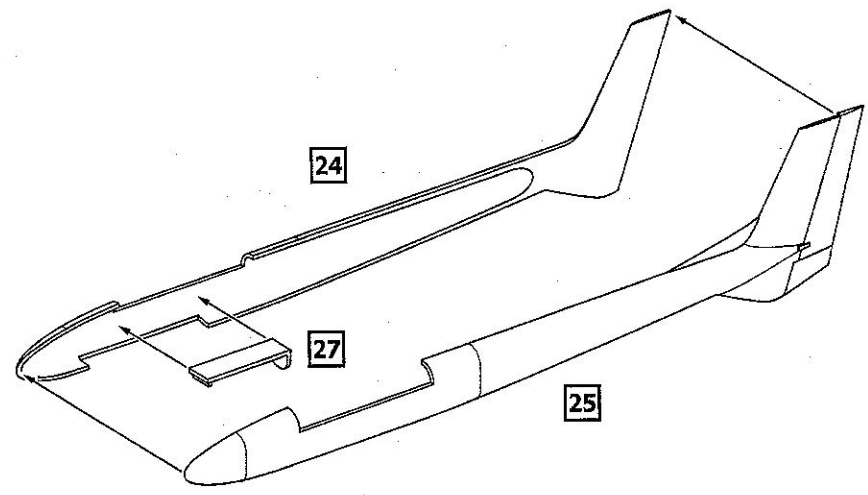

4

28

29

31

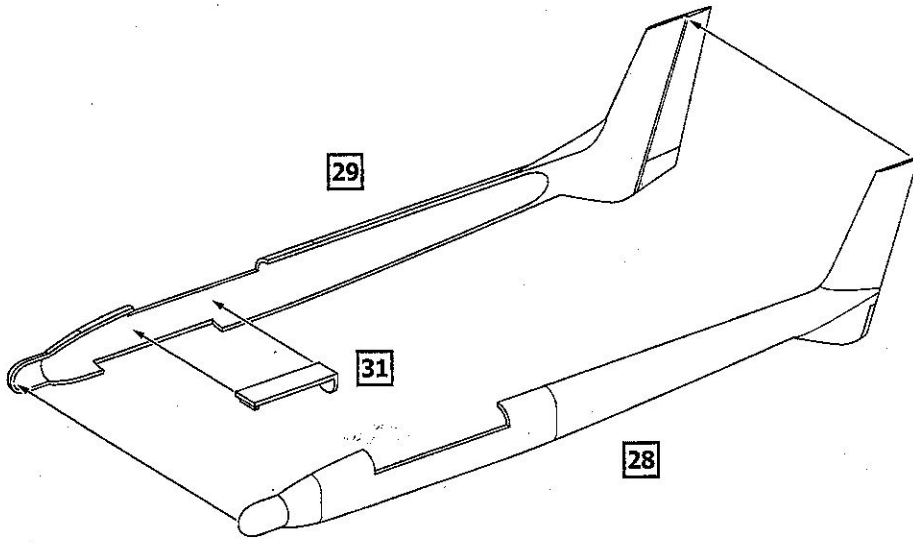

5

2

20

21

23

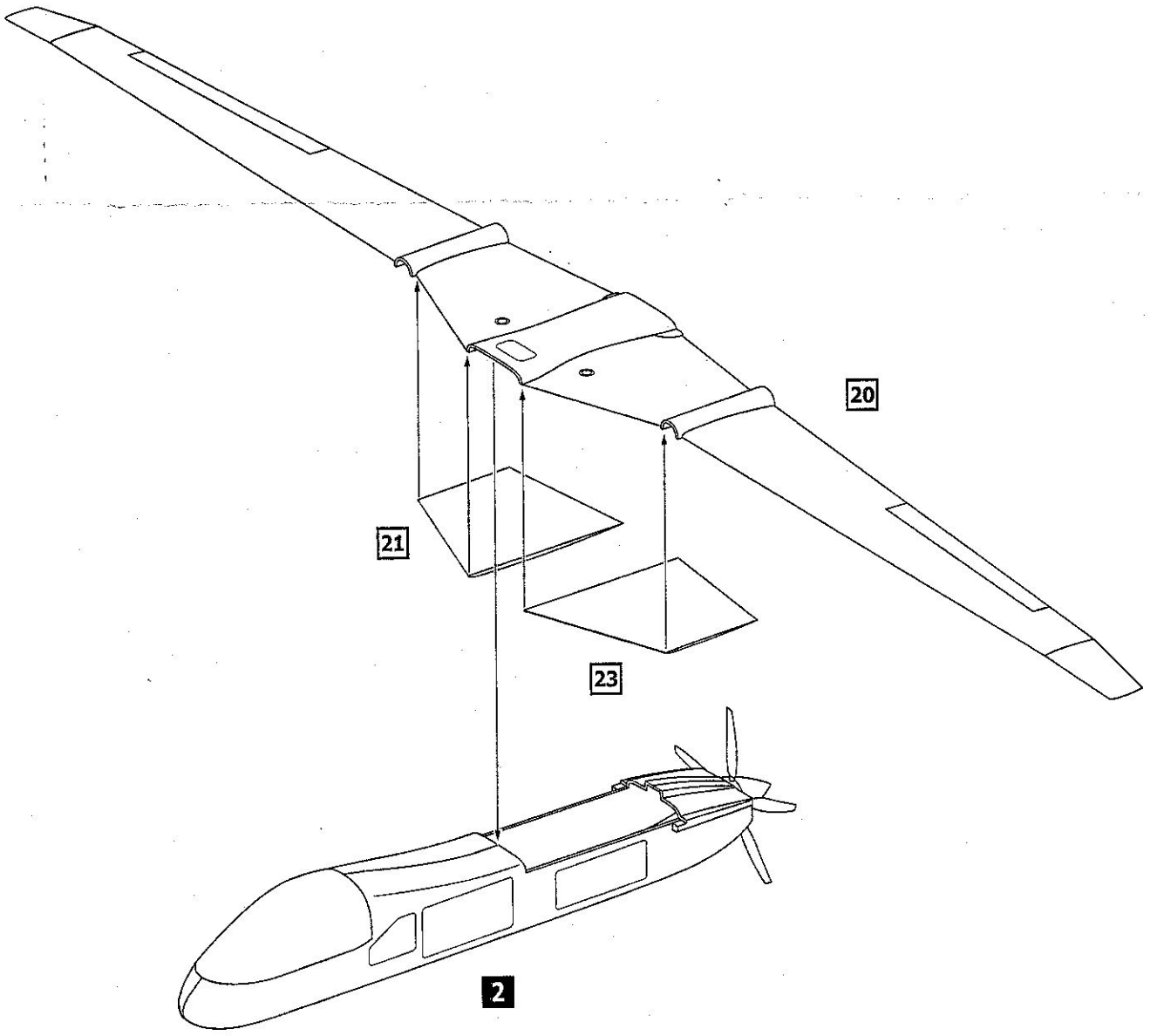

ASSEMBLY INSTRUCTION



- 6
- 3
- 4
- 5
- 22
- 44
- 45

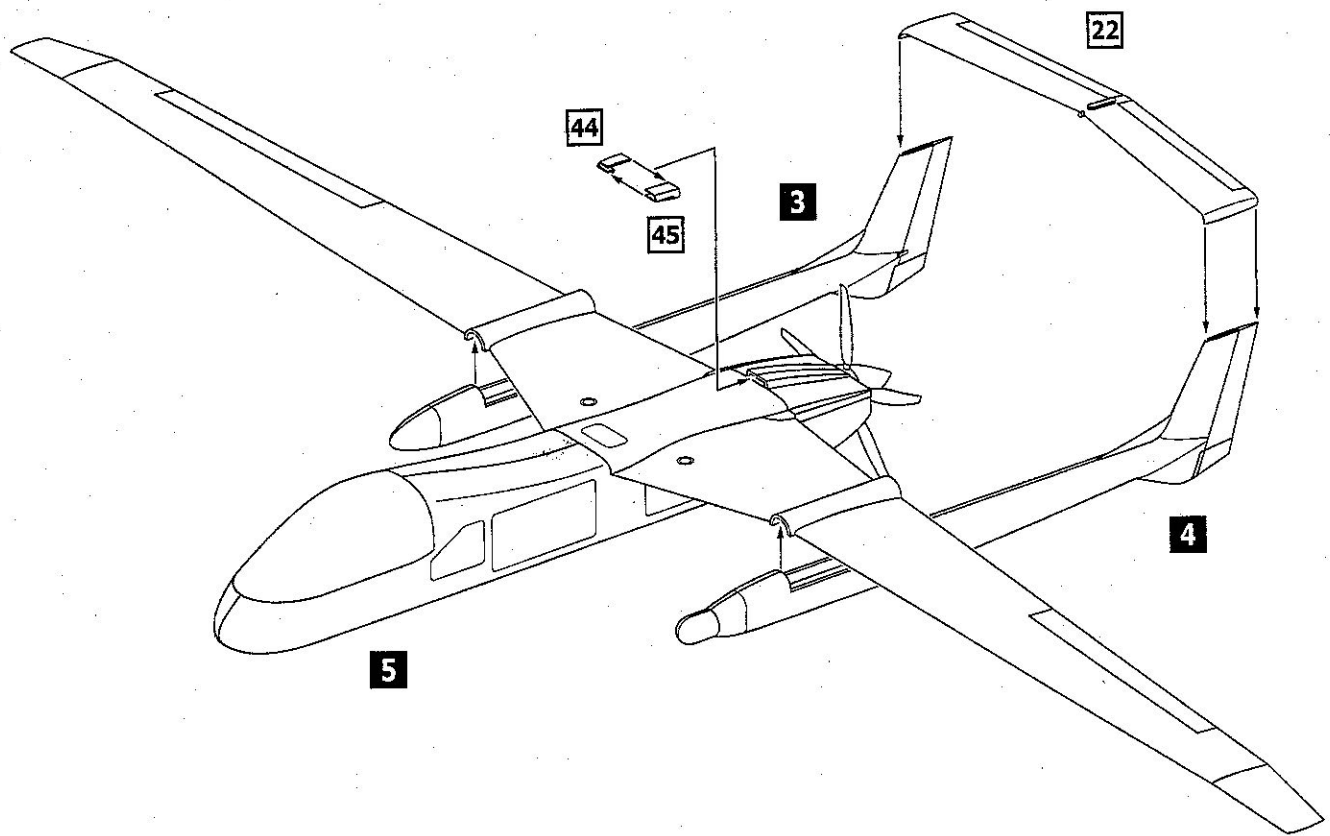

- 7
- 6
- 6
- 7
- 8
- 9 x2
- 11 x2
- 51 x2

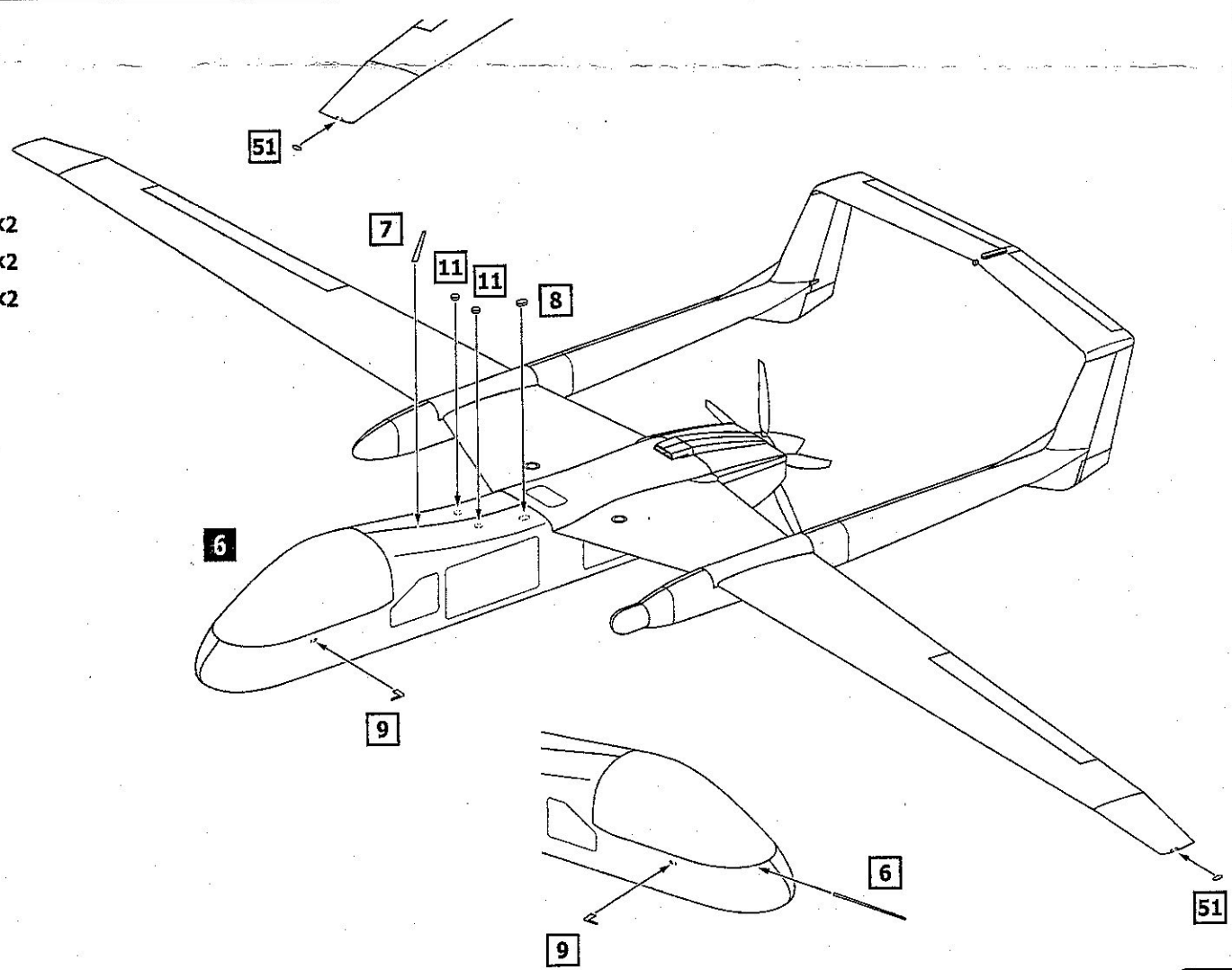



- 8**
- 7**
- 10** x2
- 26**
- 30**
- 33** x2
- 34** x2
- 35** x2
- 36** x2
- 37** x2

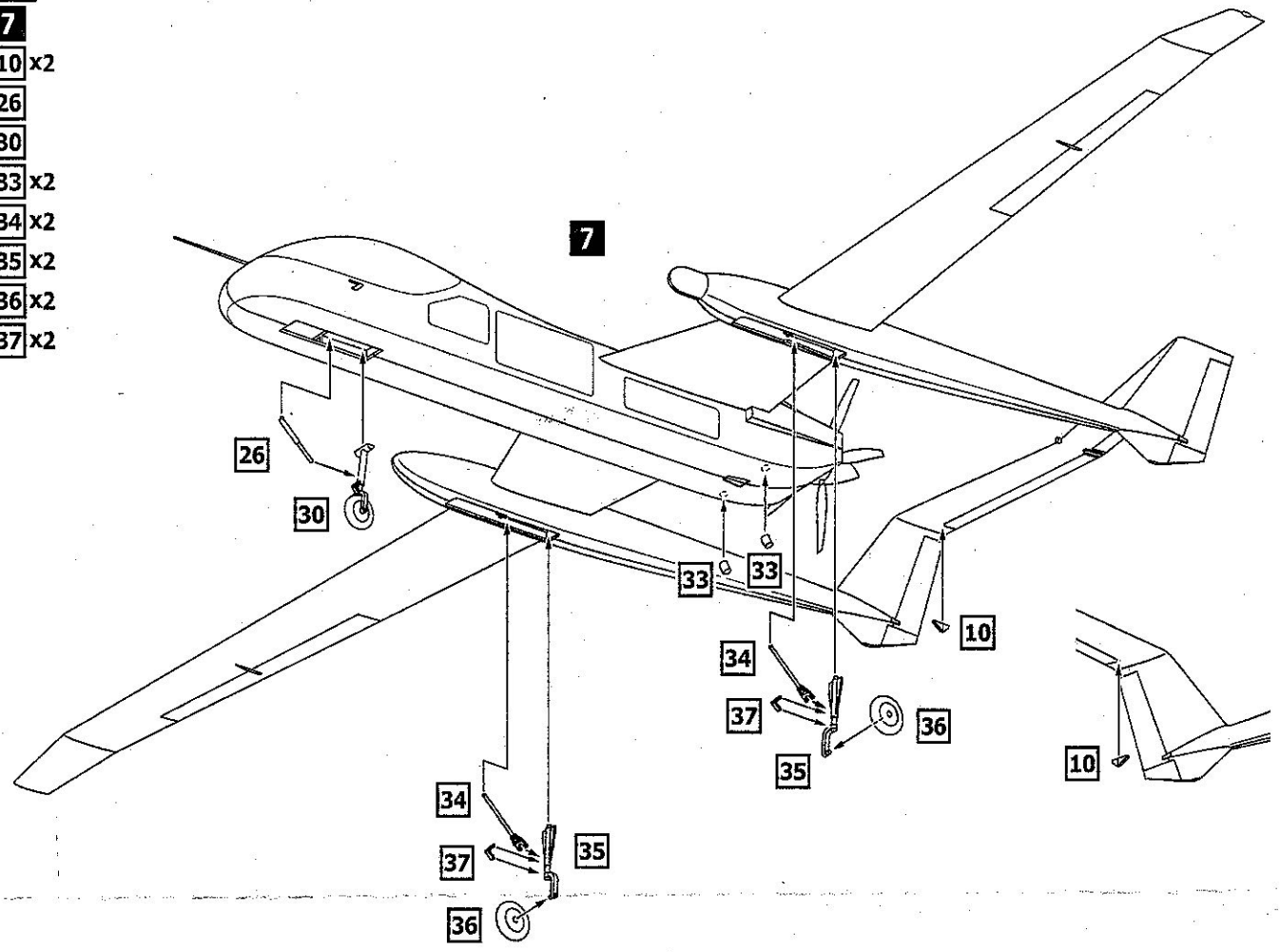

- 9**
- 8**
- 7**
- 13**
- 14**
- 32**
- 38**
- 40**
- 41** x4
- 42** x4
- 43** x4

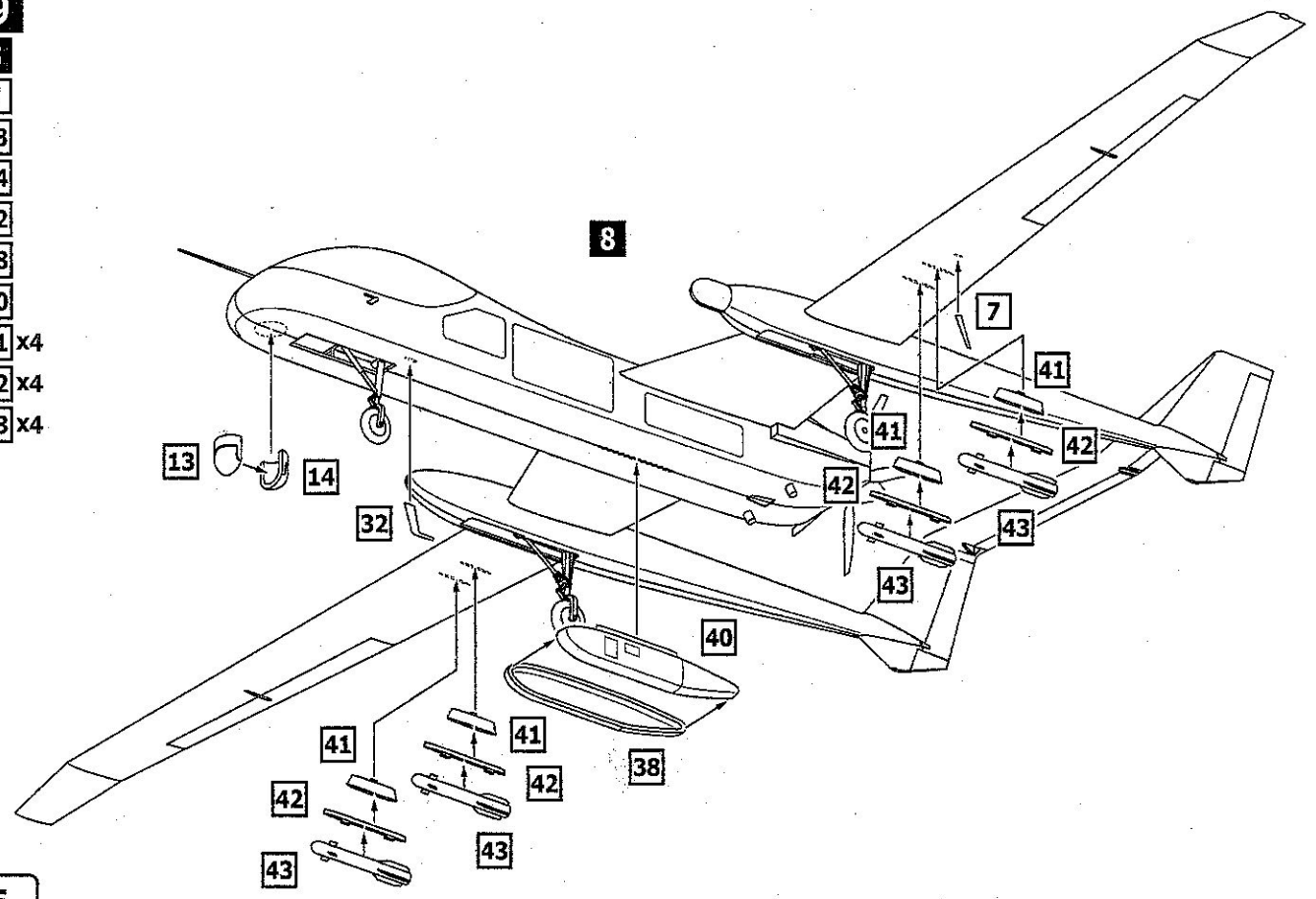

MARKING & PAINTING

Northrop Grumman Firebird

