

Popisky / Stencils

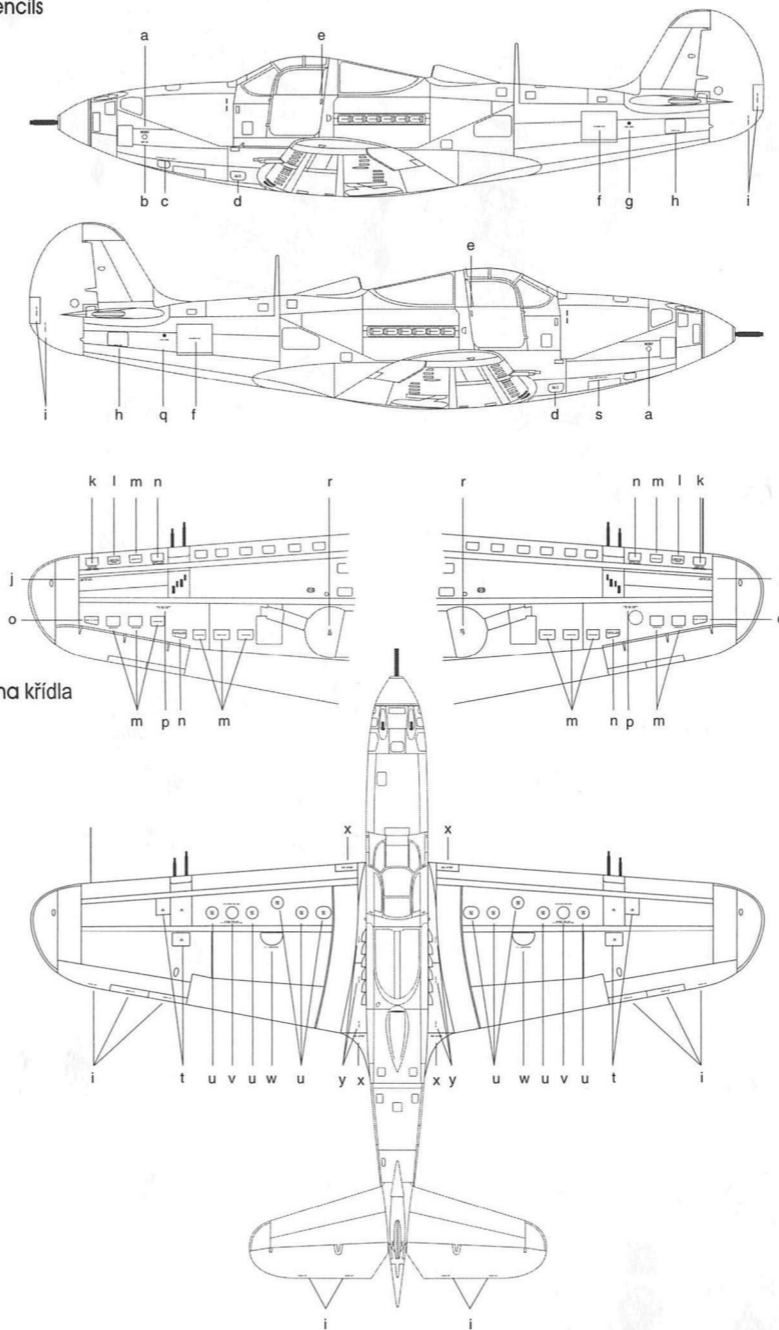

Spodní strana křídla  
Under side



P-39 L/N Airacobra  
Americký stíhací letoun / American WW II fighter



P-39 L/N Airacobra  
Americký stíhací letoun / American WW II fighter



The Bell P-39N was the first version of the Airacobra to be produced in large numbers, with a total of production run of 2,095 aircraft. All three were powered by the Allison V-1710-85 engine, and could carry 75 US gallon and 175 US gallon belly fuel tanks. All 500 P-39Ns used the 10ft 4in AeroProducts propeller. The 900 P-39N-1s differed from the P-39N only in that they used the 11ft 7in AeroProducts propeller. The P-39N-2 designation was given to 128 P-39N-1s converted to act as photographic recon-naissance aircraft. The N-3 designation was given to a further 35 aircraft converted in the same way. The 695 P-39N-5s were similar to the -1, but with a series of minor changes. The bullet-proof glass behind the pilot's head was replaced with armour plate, while the radio and oxygen systems were improved. 1113 of P-39N were exported to USSR.

92132

Stavební návod / Instruction

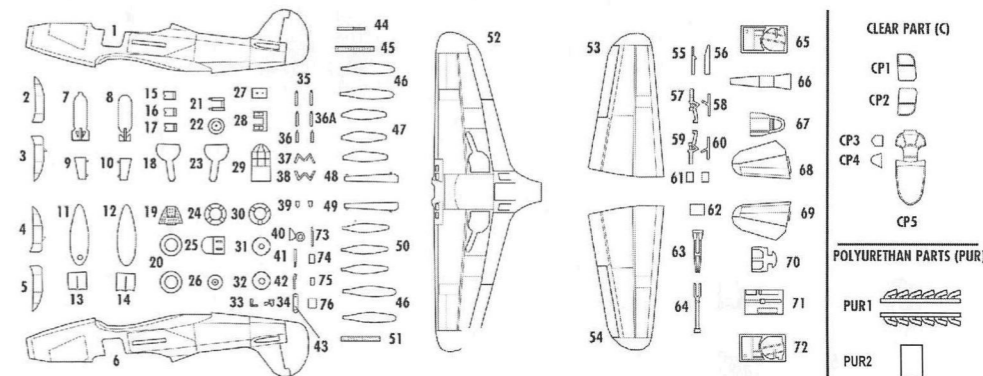

LEGEND



COLORS

a	Černá Black	b	Červená Red
c	Stříbrná Silver	d	Bílá White
e	Žlutá Yellow	f	Žlutá Yellow
g	Přímo Linen	h	Pneumatiky Tyres Black
i	Kůže Leather	j	Rezová Rust
k	Hliníková Aluminium	l	Tmavá šedá Dark Grey
m	Chromová Chrome	n	Kovová Gun metal
o	Olivová Olive	p	Inter. zelená Zinc Chromate green

