

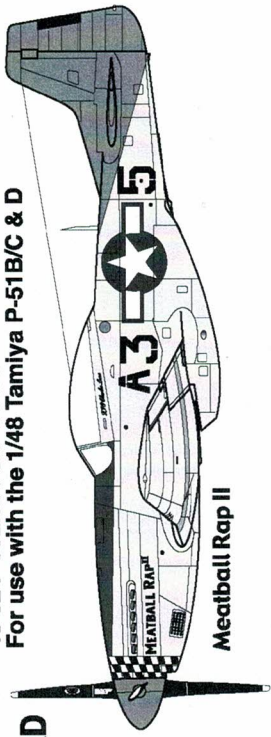

48 024 332nd FG P-51C/D  
For use with the 1/48 Tamiya P-51B/C & D

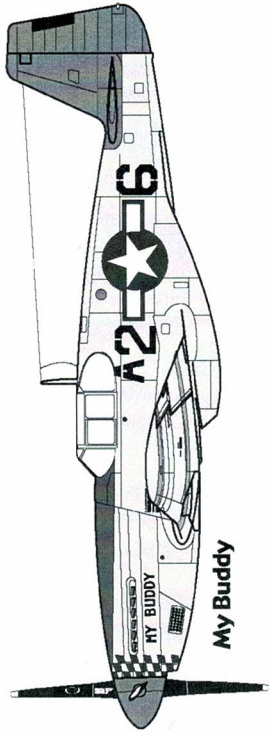

Meatball Rap II



My Buddy

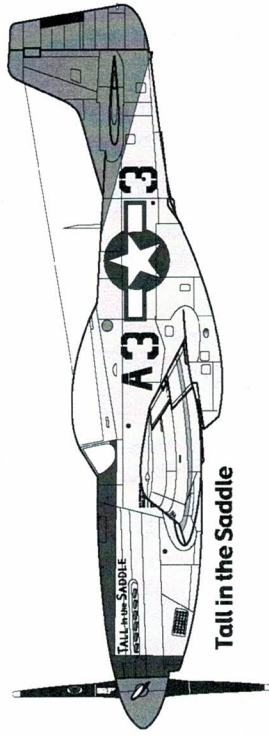

Tall in the Saddle

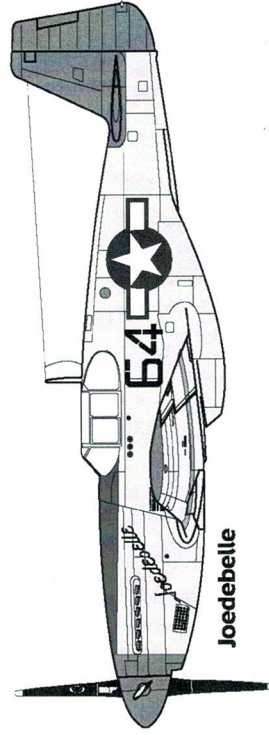

Joedebelle

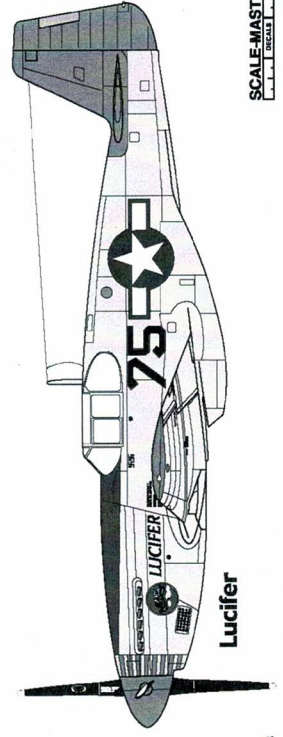

Lucifer

48 024  
Tuskegee P-51D  
For use with the 1/48 Tamiya P-51D

P-51D MEATBALL RAP II  
Flt. Off. Charles Lane  
99th FS, 332nd FG  
Ramitelli, Italy, March 1945

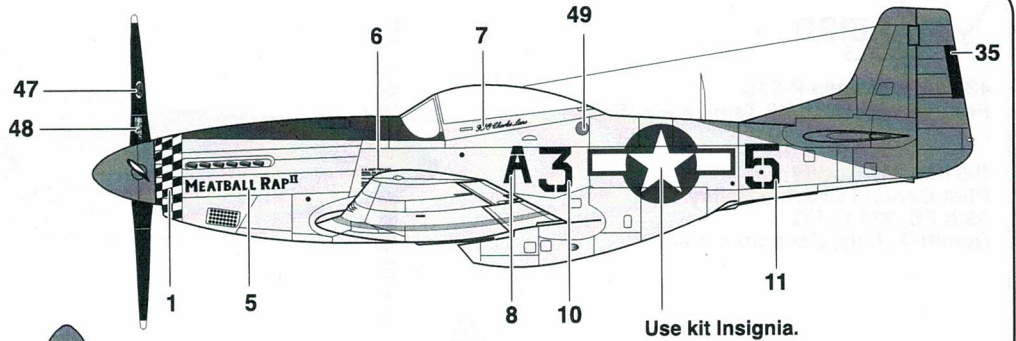

Use kit Insignia.

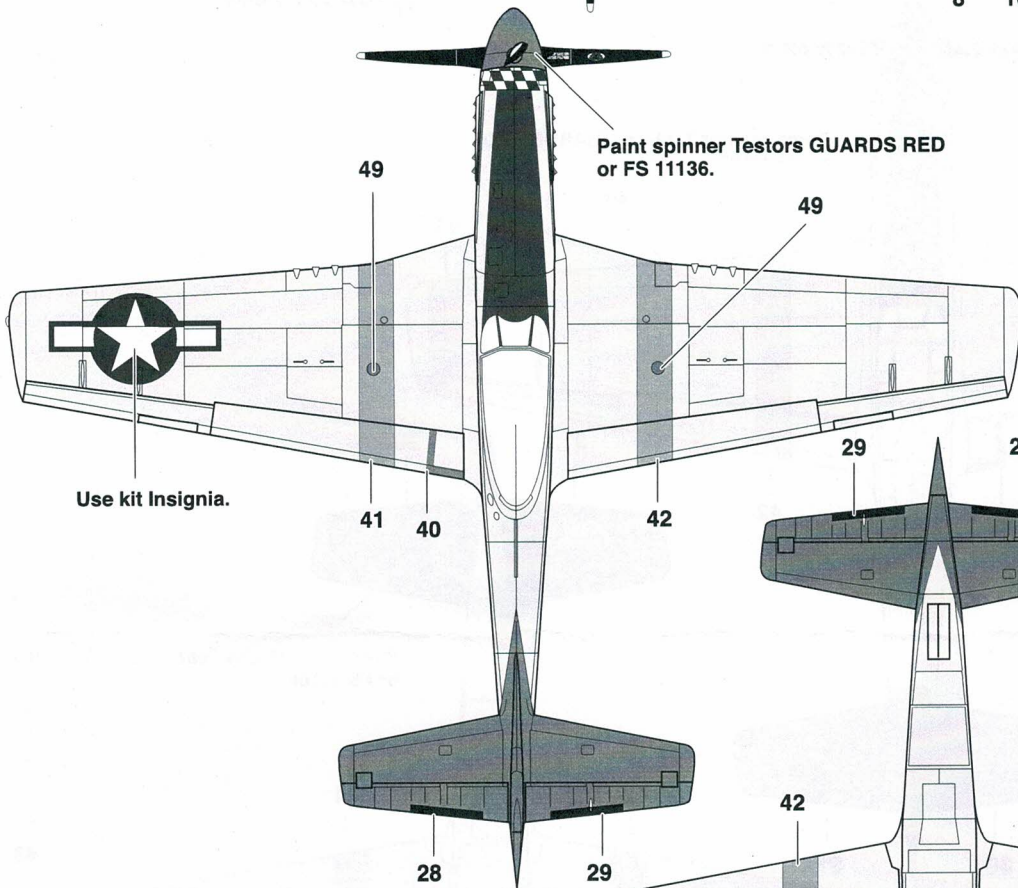

Use kit Insignia.

Paint spinner Testors GUARDS RED or FS 11136.

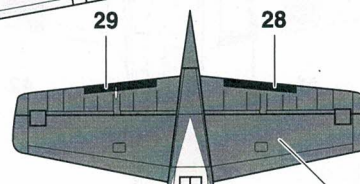

Paint tail surfaces Testors GUARDS RED or FS 11136.

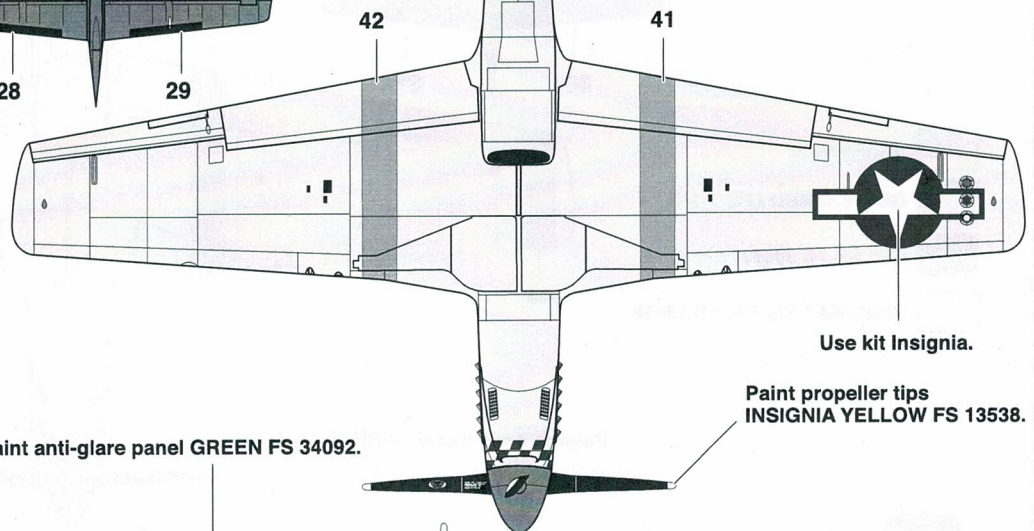

Use kit Insignia.

Paint propeller tips  
INSIGNIA YELLOW FS 13538.

Paint anti-glare panel GREEN FS 34092.

-  ALUMINUM
-  GUARDS RED / FS 11136
-  GREEN FS 34092
-  INSIGNIA YELLOW FS 13538

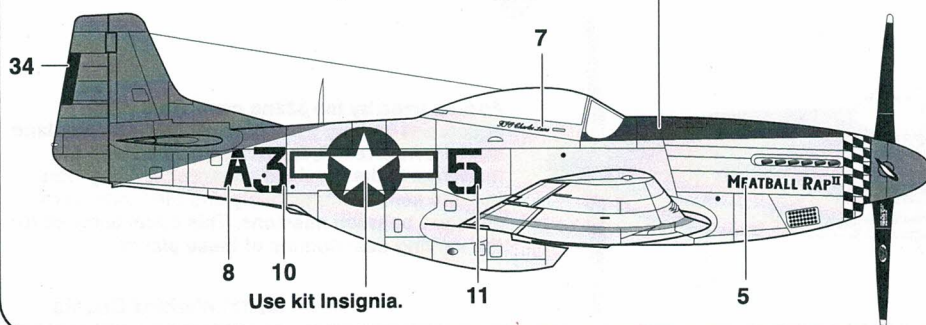

Use kit Insignia.

Aircraft used by the 332nd came from other squadrons as they were replaced by later Mustang models. As a result, the planes arrived with the markings of the previous squadrons. They were put into service immediately and markings were changed between missions. This could account for the varying descriptions of these planes.



48 024 Tuskegee P-51C  
For use with the 1/48 Tamiya P-51B/C

P-51C My Buddy  
Pilot Captain Charles Bailey  
99th FS, 332nd FG  
Ramitelli, Italy, December 1944

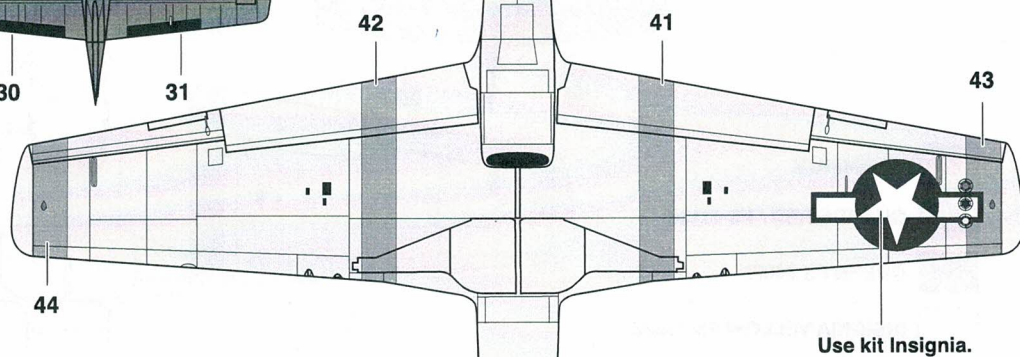
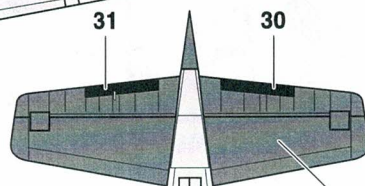
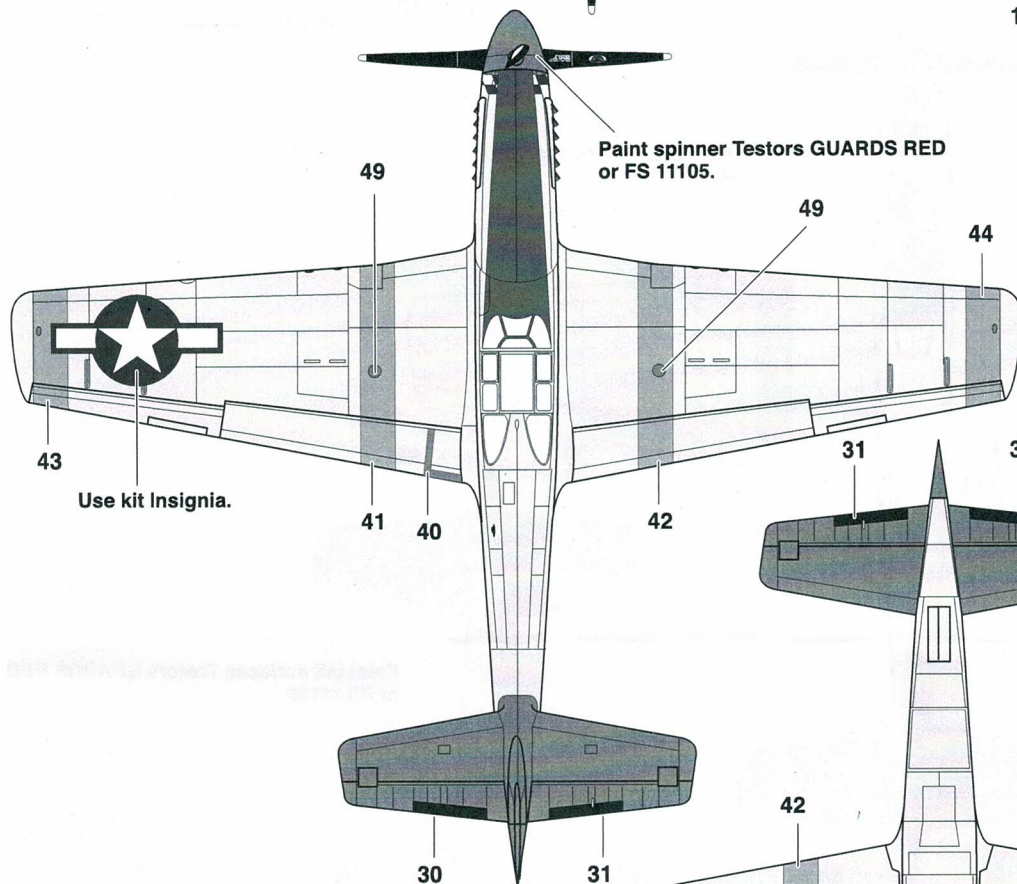
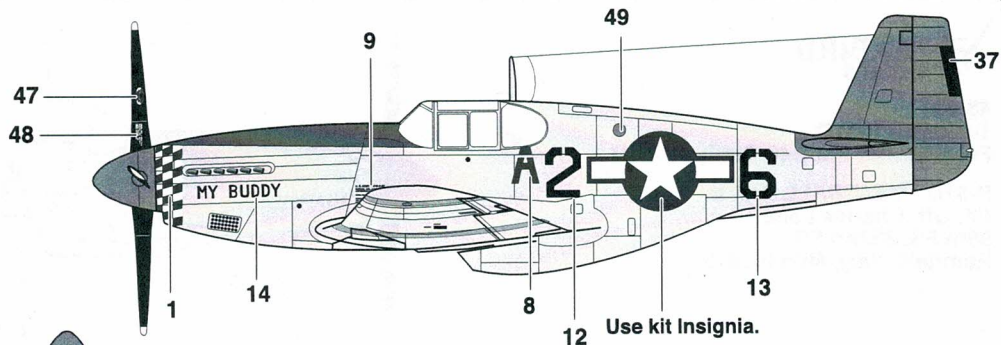

Paint propeller tips  
INSIGNIA YELLOW FS 13538.

- ALUMINUM
- GUARDS RED / FS 11105
- GREEN FS 34092
- INSIGNIA YELLOW FS 13538

Paint anti-glare panel GREEN FS 34092.

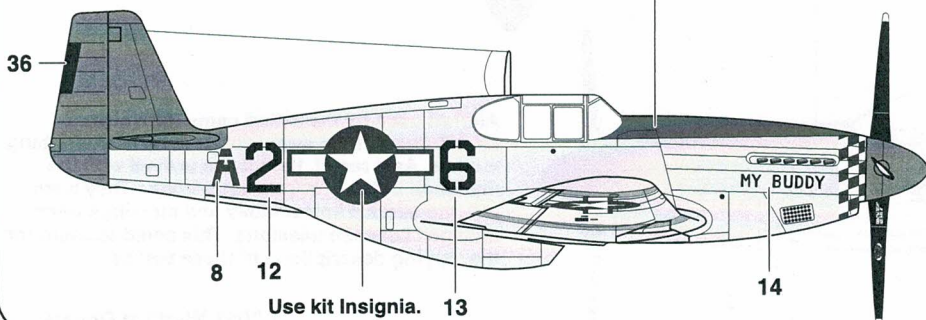

Aircraft used by the 332nd came from other squadrons as they were replaced by later Mustang models. As a result, the planes arrived with the markings of the previous squadrons. They were put into service immediately and markings were changed between missions. This could account for the varying descriptions of these planes.

48 024  
Tuskegee P-51D  
For use with the 1/48 Tamiya P-51D

P-51D Tall in the Saddle  
1st. Lt. George Hardy  
99th FS, 332nd FG  
Ramitelli, Italy, February 1945

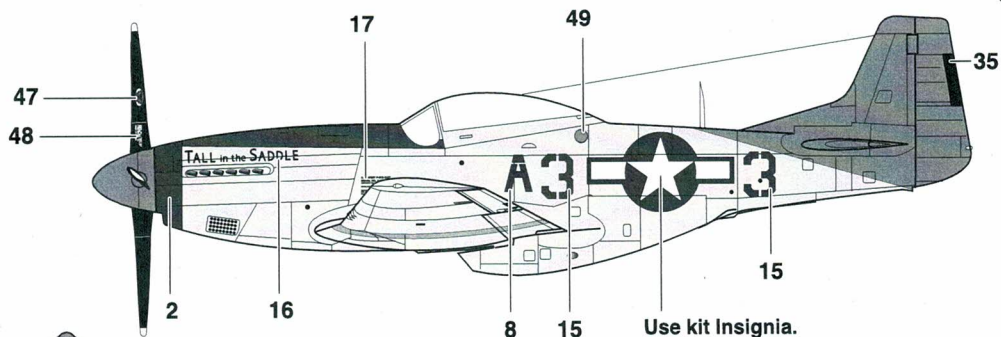

Use kit Insignia.

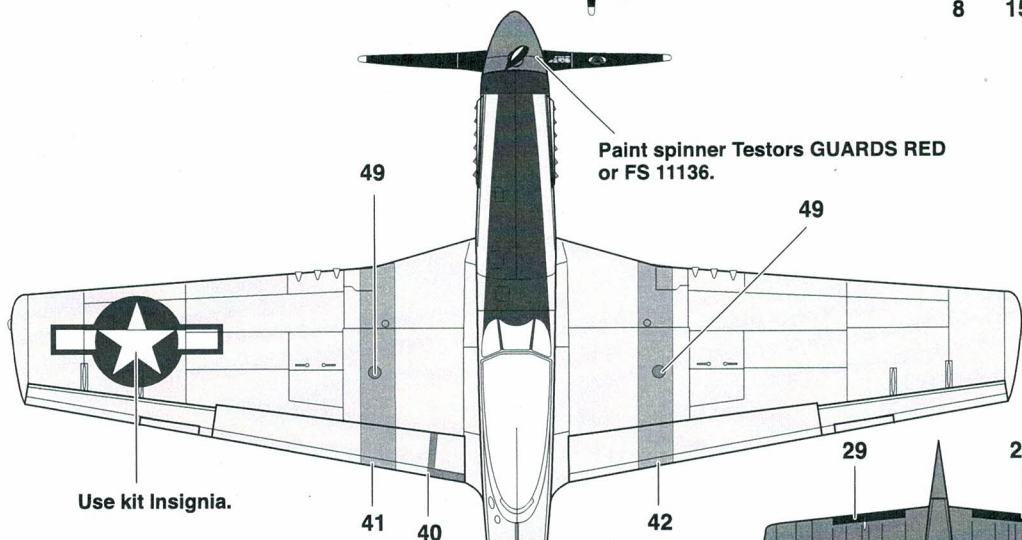

Use kit Insignia.

Paint spinner Testors GUARDS RED  
or FS 11136.

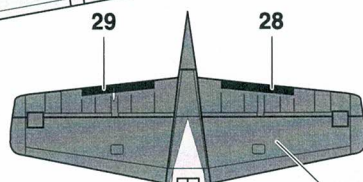

Paint tail surfaces Testors GUARDS RED  
or FS 11136.

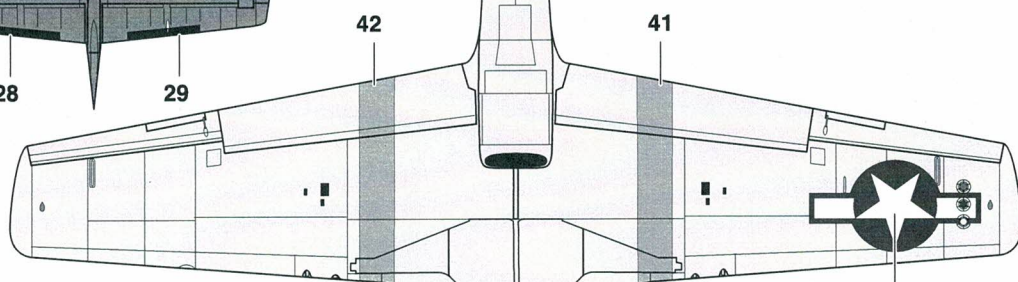
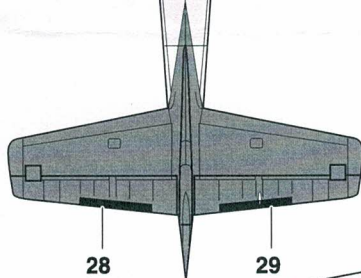

Use kit Insignia.

Paint propeller tips  
INSIGNIA YELLOW FS 13538.

-  ALUMINUM
-  GUARDS RED / FS 11136
-  GREEN FS 34092
-  INSIGNIA YELLOW FS 13538

Paint anti-glare panel GREEN FS 34092.

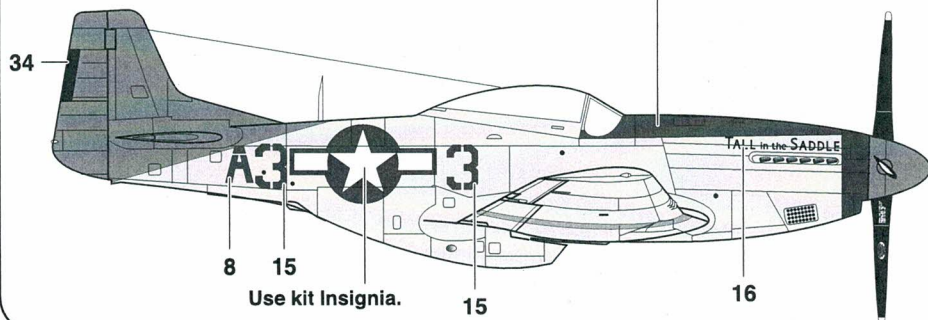

Use kit Insignia.

Aircraft used by the 332nd came from other squadrons as they were replaced by later Mustang models. As a result, the planes arrived with the markings of the previous squadrons. They were put into service immediately and markings were changed between missions. This could account for the varying descriptions of these planes.





72 019  
 Tuskegee P-51C  
 For use with the 1/72 Hasagawa P-51B/C

P-51C Joedebelle  
 Pilot Captain Joseph Elsberry  
 301st FS, 332nd FG  
 Ramitelli, Italy, July 1944

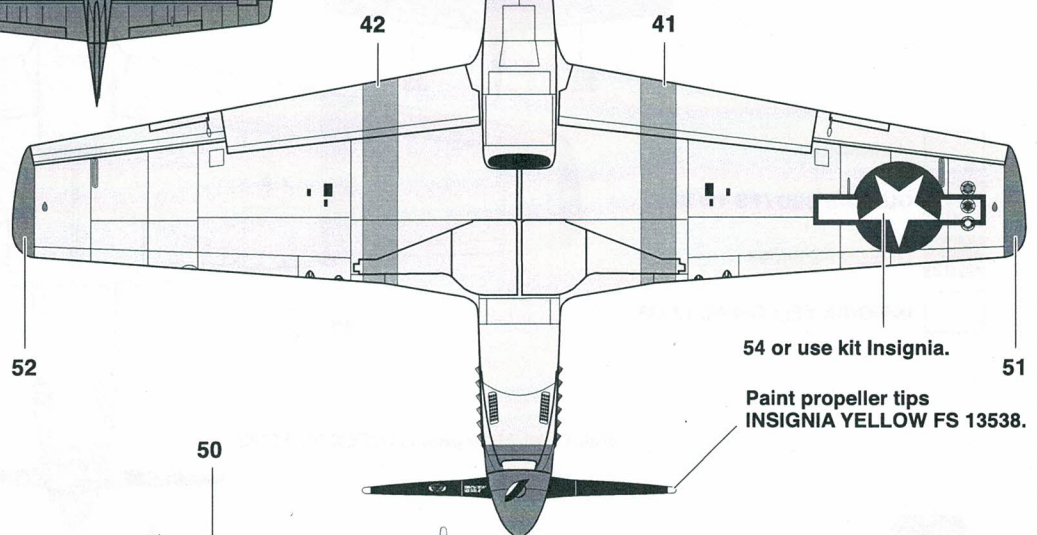
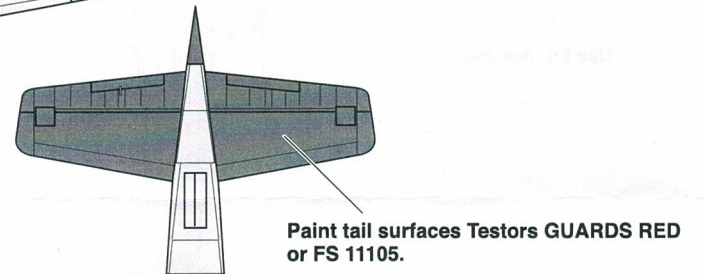
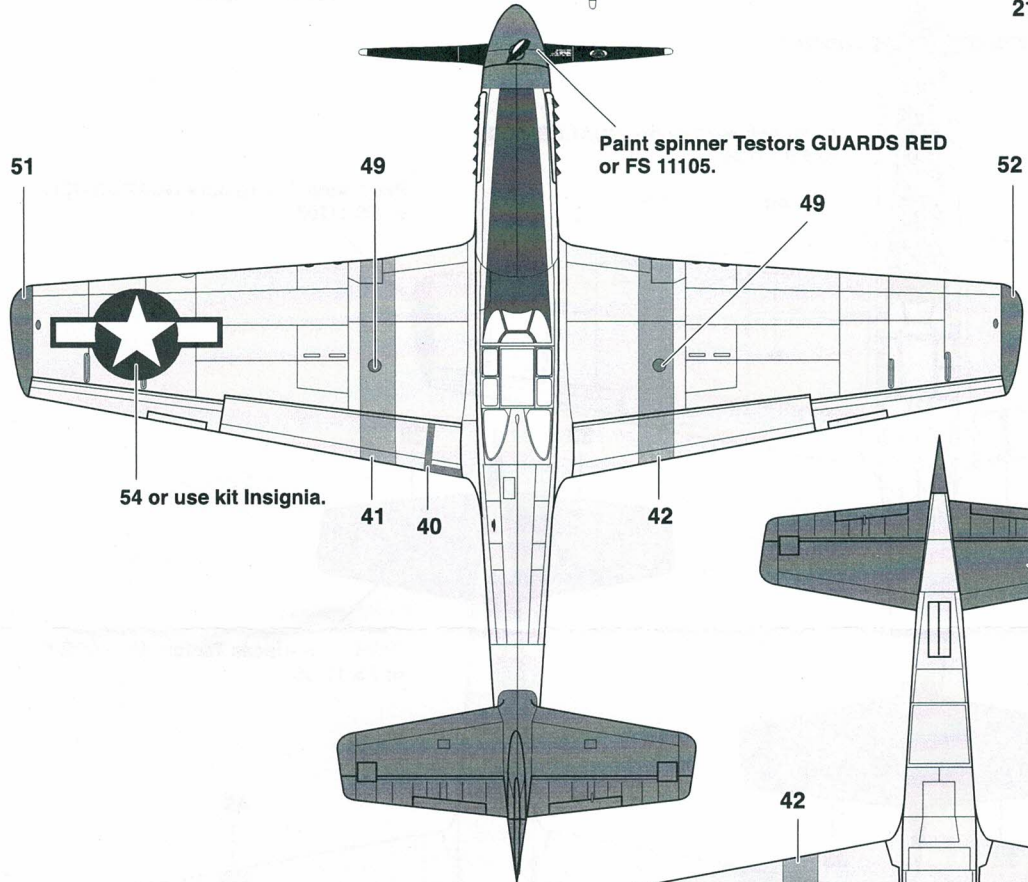
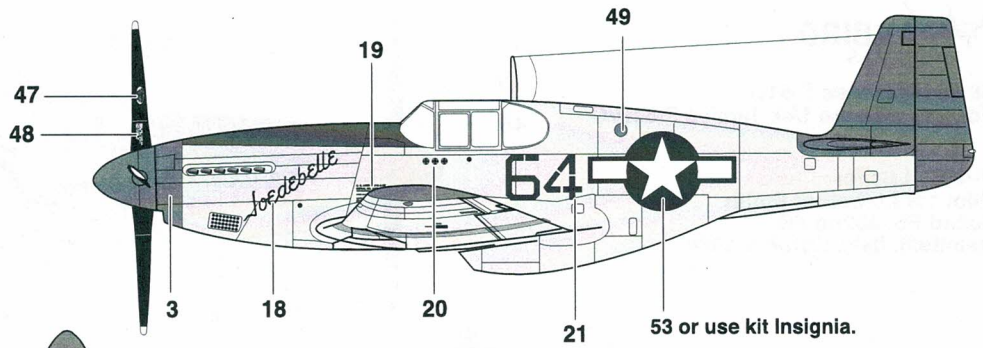

- ALUMINUM
- GUARDS RED / FS 11105
- INSIGNIA YELLOW FS 13538

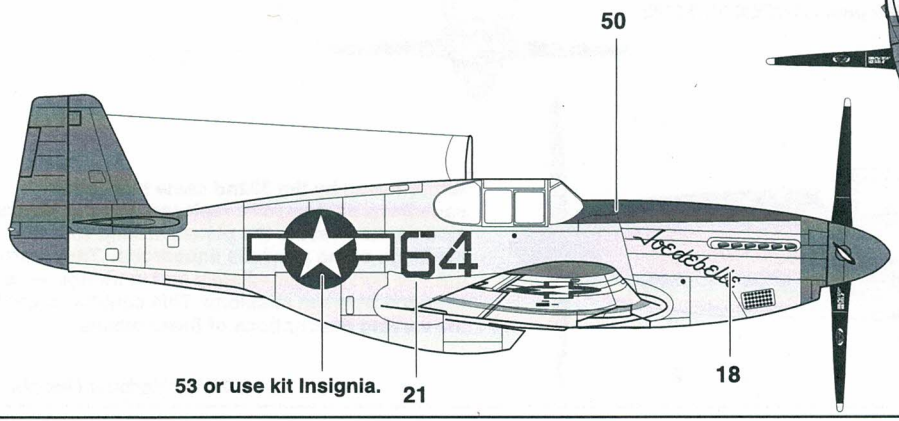

Aircraft used by the 332nd came from other squadrons as they were replaced by later Mustang models. As a result, the planes arrived with the markings of the previous squadrons. They were put into service immediately and markings were changed between missions. This could account for the varying descriptions of these planes.





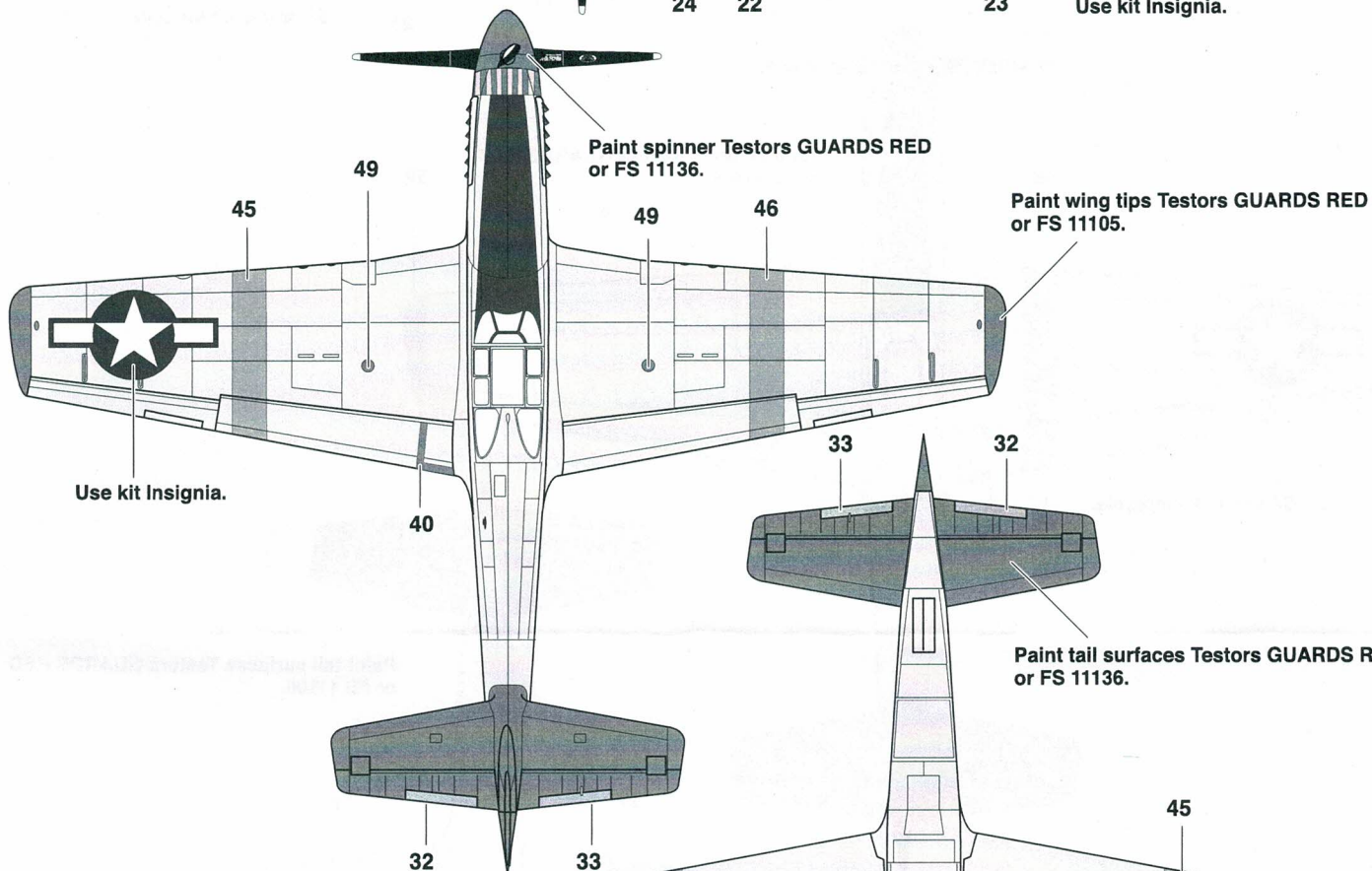
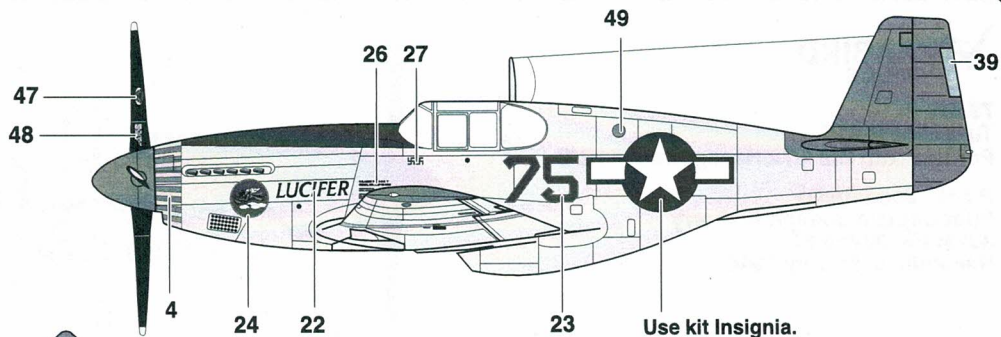

48 024 Tuskegee P-51C  
For use with the 1/48 Tamiya P-51B/C

P-51C Lucifer  
Pilot 1st Lt. Luther Smith  
302nd FS, 332nd FG  
Ramitelli, Italy, October 1944



Paint tail surfaces Testors GUARDS RED or FS 11136.

-  ALUMINUM
-  GUARDS RED / FS 11136
-  GREEN FS 34092
-  INSIGNIA YELLOW FS 13538

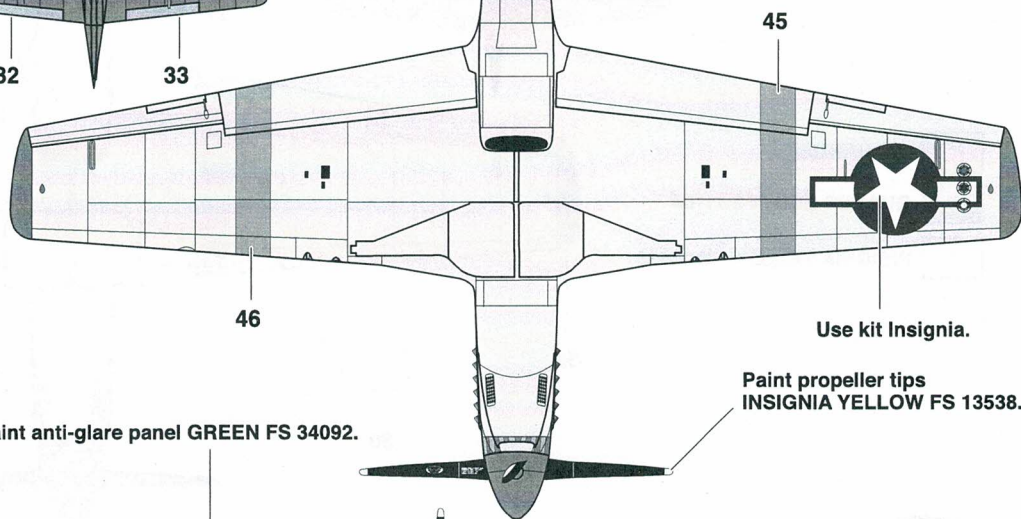

Paint propeller tips INSIGNIA YELLOW FS 13538.

Paint anti-glare panel GREEN FS 34092.

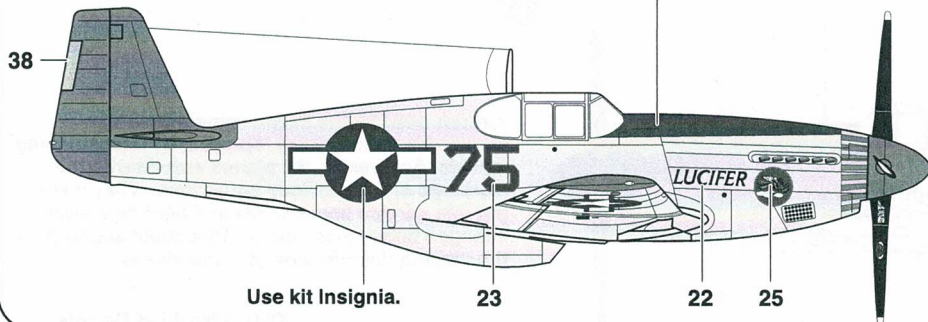

Aircraft used by the 332nd came from other squadrons as they were replaced by later Mustang models. As a result, the planes arrived with the markings of the previous squadrons. They were put into service immediately and markings were changed between missions. This could account for the varying descriptions of these planes.