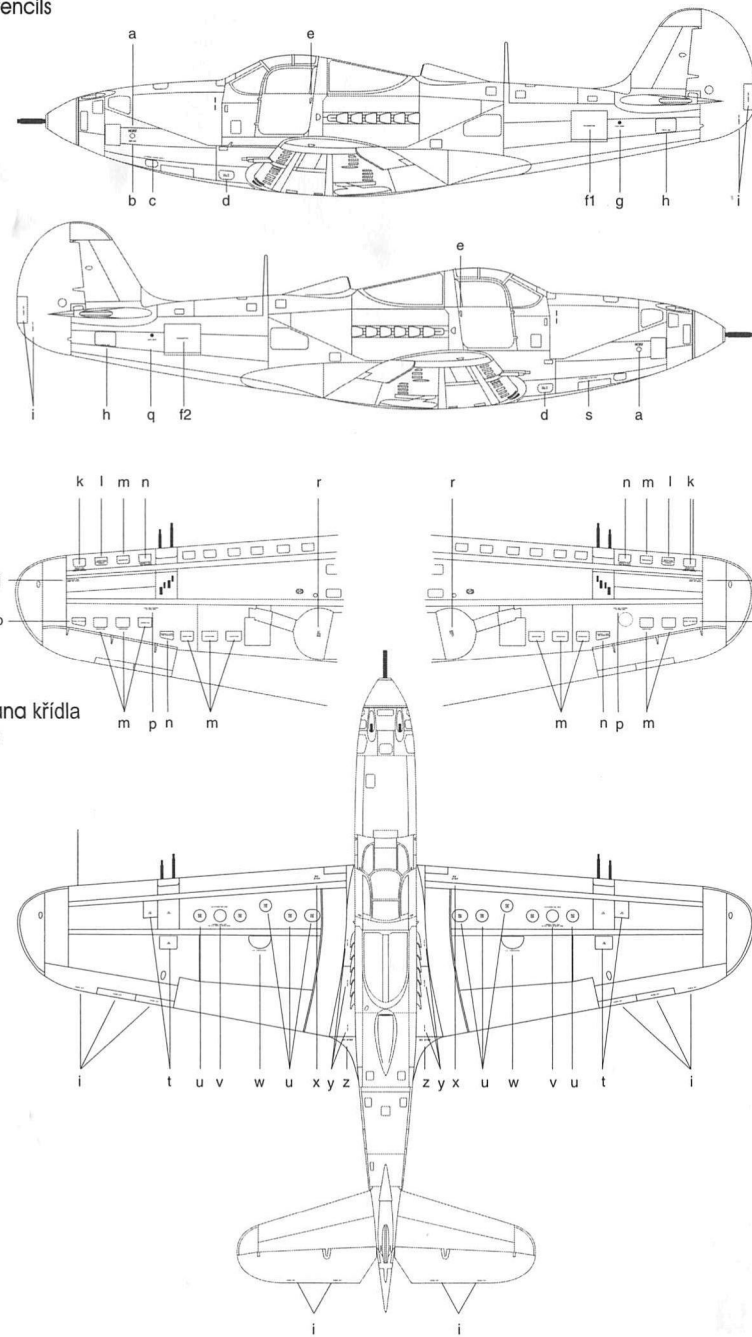
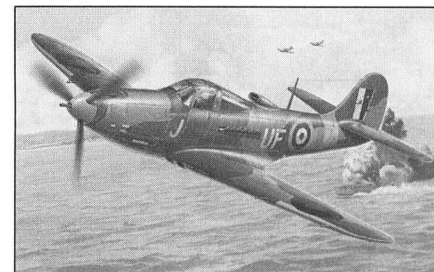

## Popisky / Stencils

Airacobra I / P-400  
Americký stíhací letoun / American WW II fighter

## Airacobra I / P-400

Americký stíhací letoun / American WW II fighter

The Airacobra entered first service with the RAF in October 1941. Only one RAF squadron ever received the Airacobra. No.601 "City of London" The Airacobra's brief RAF combat career lasted from 9-11 October 1941. No.601 Squadron sent its four airworthy aircraft on two fighter sweeps to France. Only eighty of the British Airacobras were assembled for the RAF. Of the remaining aircraft around 200 were quickly dispatched to the Soviet Union while the rest remained in the United States, and as the P-400 fought on New Guinea and Guadalcanal.

92131

## Stavební návod / Instruction

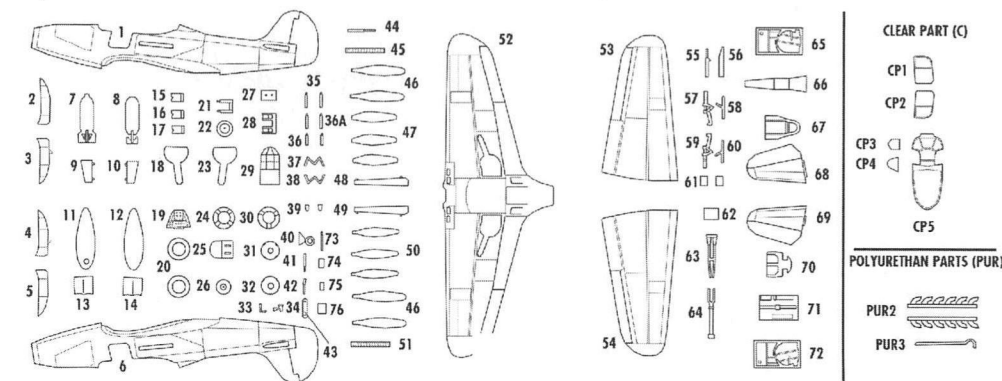

## LEGEND



## COLORS

a Černá Black	h Červená Red
b Interier, žlutá Yellow primer	i Bílá White
c Stříbrná Silver	j Žlutá Yellow
d Pádné Linen	k Pneumatiky Tyres Black
e Kůže Leather	l Rezavá Rust
f Hliníková Aluminium	m Tmavá šedá Dark Grey
g Chromová Chrome	n Kovová Gun metal
p Olivová Olive	o Inter. zelená Zinc Chromate green

