



ON TARGET
Conversion Sets

AIR-GRAPHICS
CS-02
1/72 SCALE



Army Air Corp
Westland

Lynx AH.7

1:72
Scale

CONVERSION SET

AIR-GRAPHIC MODELS

1

Stage 1 - Side Profile

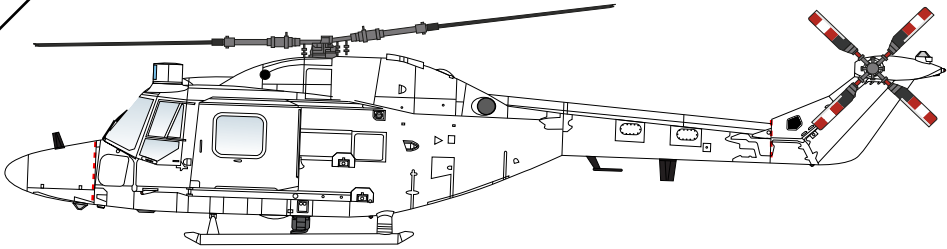

1

Stage 1 - Fuselage alteration Forward Cabin/cockpit windows

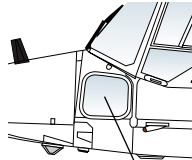

Shape of windows
both sides.
Replace with new
clear resin items.

We recommend the
inner cabin roof guides
are cut off.

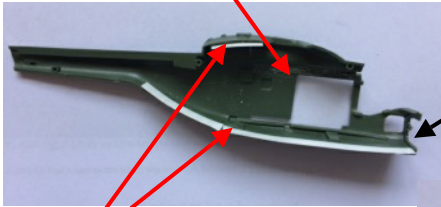

The Airfix kit has always been poor
along the fuselage joints with very
few location lugs. We have used
thin plasticard along the joints as
shown

Do not fit kit clear
parts No 38 & 45.
Amend opening to
suit new clear resin
windows which are the
correct shape.

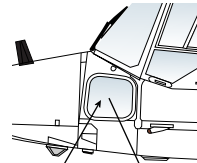

Shape of windows
both sides.
Replace with new
clear resin items.

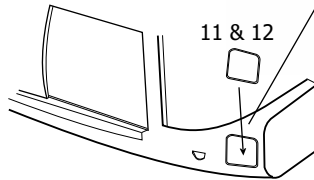

11 & 12

Modellers Notes*

Cut of nose
Section to both
Fuselage half's



Front cabin window shape alerted



Tail rotor cut off

3

Standard AH.7 cabin roof

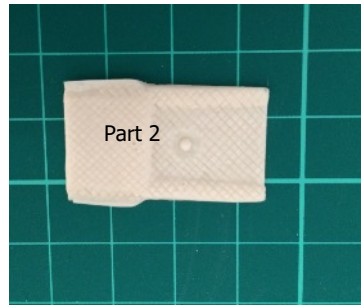
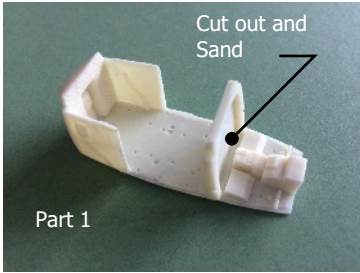

Paint and detail the cabin roof before fixing. See detailed photos and painting guide.

It is important to fit the parts in numerical order so that access can be obtained to the rear cabin area.

Stage 2: Cabin preparation.

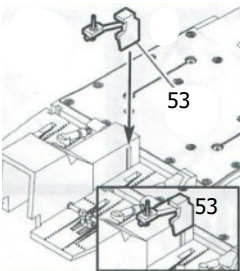
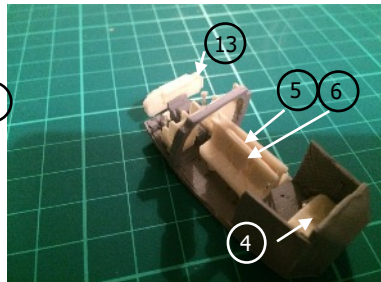
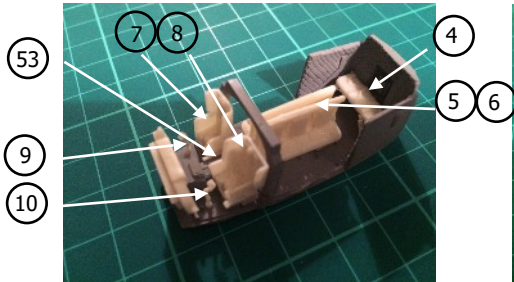

Almost all the Lynx have the rear seats fitted.

3 cont

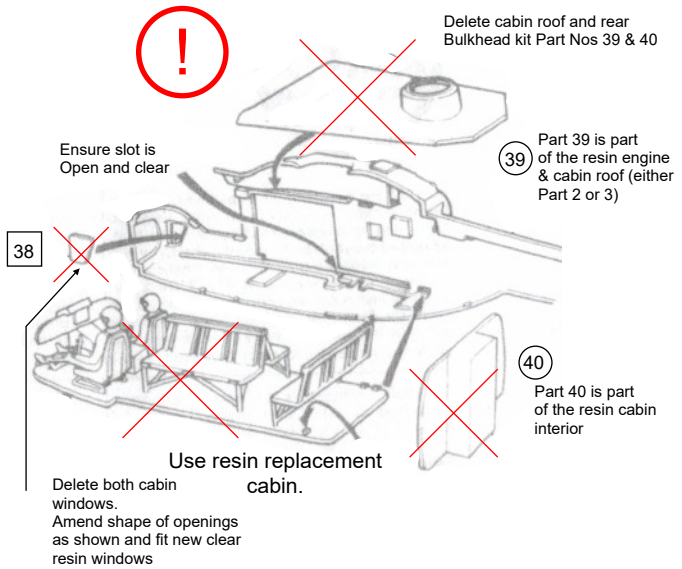

4a

Engine Deck Detailing - Standard AH.7

Cut away view

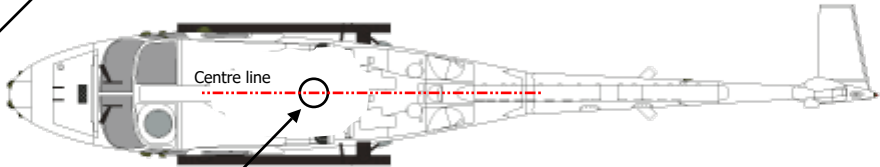

Fit Part 14



Fit rotor head base Plate Part No 14 To underside of rotor housing. Note which way around it goes as this should fit snugly under the kit part.

Note 1mm hole drilled through Resin housing for rod so that rotor head assembly can be removed if required.

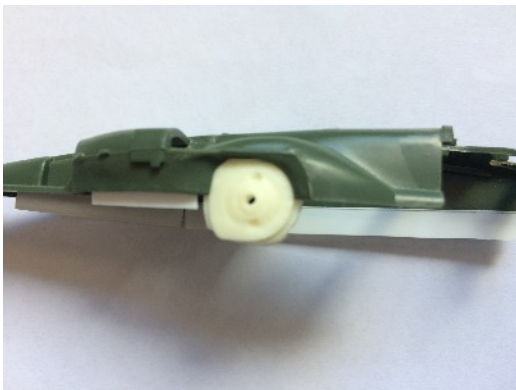

4b

Standard Lynx AH7 - Engine deck detail

Fit either standard intake filters from the kit.
Or new particle sand filter intake guards
Part 15 and 16

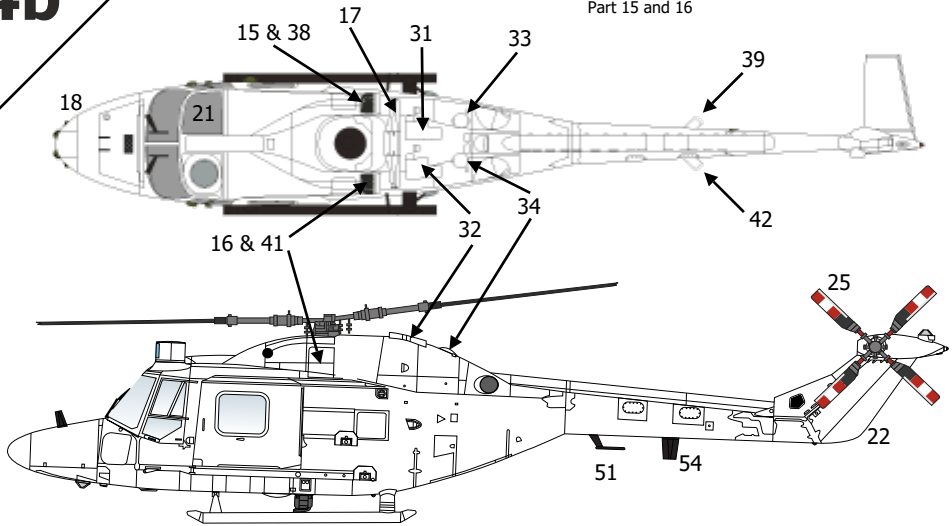

Photo Above & Below: Note standard AH.7
but with particle sand filter intake guards
Part no 15/38 and 16/41



5



Alternatively, you can cut this part from Part 3 and use the gun sight

Part 68 - Paint/tint inside of glass black/smoke. We recommend 2 coats of Tamiya Smoke X19

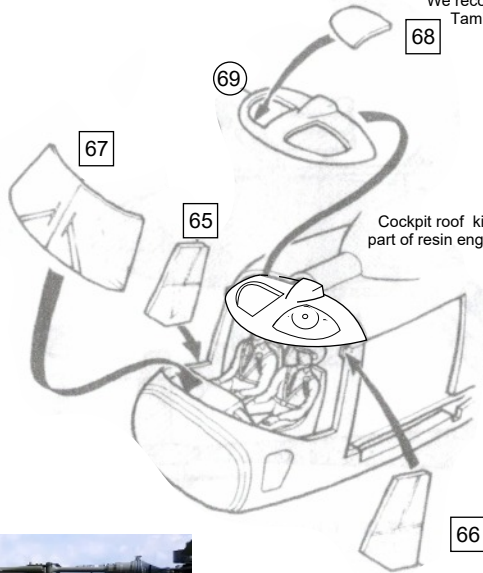

6

Replace tail and tail rotor assembly

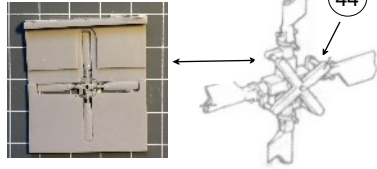
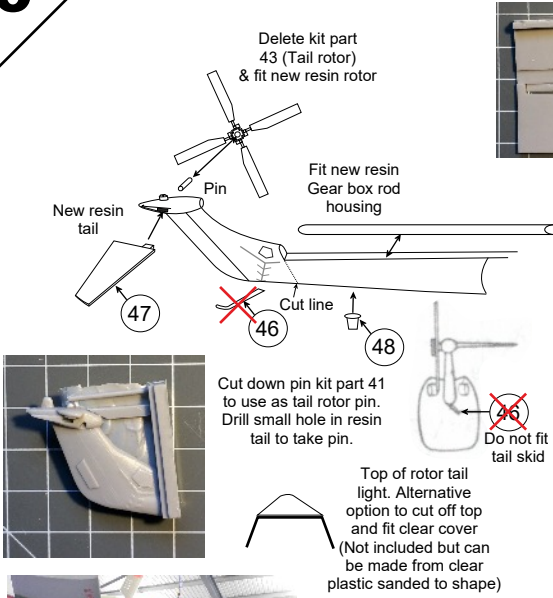

7

Clear navigation light

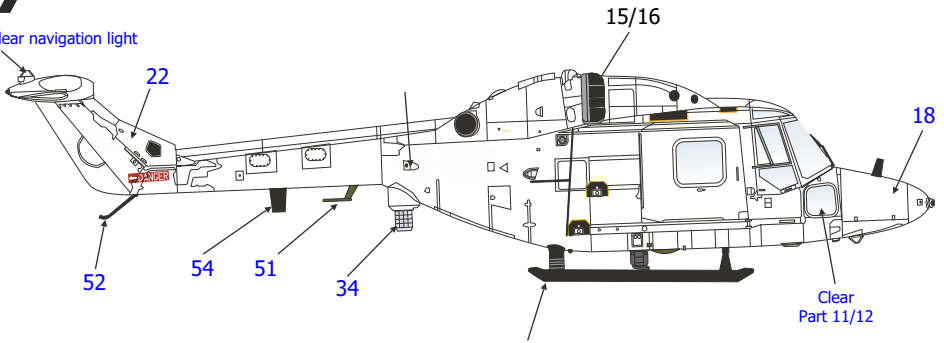

Clear navigation light

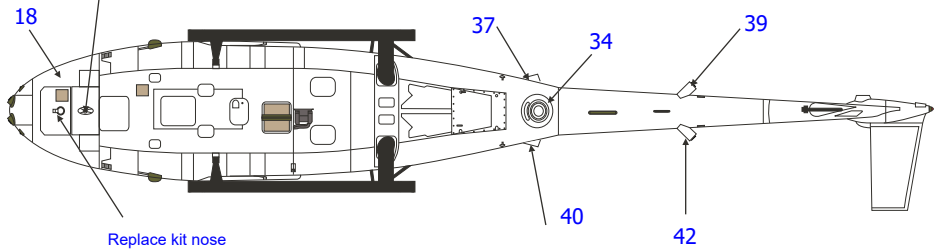

Replace kit nose

with resin replacement Part 18. Drill out the nose

Light aperture 3mm. Paint recess silver

before putting kit part 74 (clear lens) in the recess.

A Bluebird clear lens can also be recessed into the resin before putting in part 74 if preferred





8

Airframe Detailing

There are a small number of items to be detailed by the modeller. This was decided as they these parts would be very difficult or fragile to make in resin and we did not want to add any brass or other materials & keep the costs down. These parts should be within the skill of the modeller undertaking this conversion set.



Photo left: Note the two blade aerials just below the cockpit glazing, these are 330mm long and mounted on a small plate 80mm x 150mm. Paint all matt Black.
Note shape of lower cockpit window.



Photo top right: Upper fuselage view of completed model showing the smoke glass cockpit roof window, the optical sight, blade aerials and the walkway markings (although on some aircraft these were painted over as can be seen on the bottom picture)

Photo lower right: Shape of lower cockpit window, door handles and small light under step on both sides. Green port and red starboard.



Kit part to top of rotor hub



Machine Gun Mount both sides

47/50

46/49

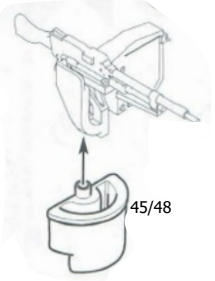

Machine gun mount 43/44

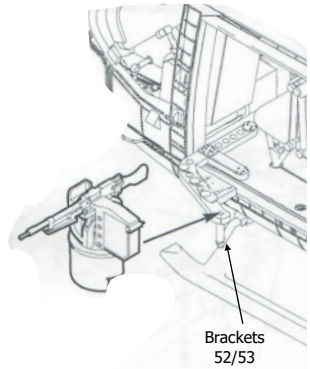
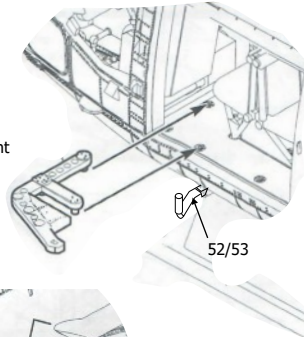

Chaff/Flare mounts on skids, both sides

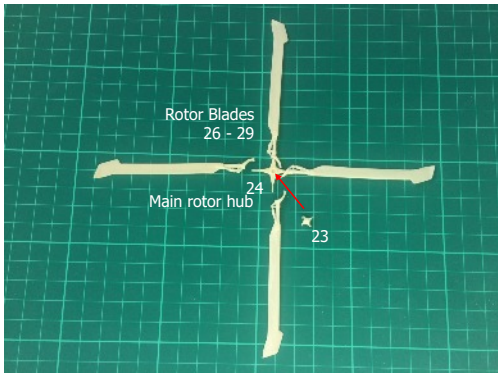
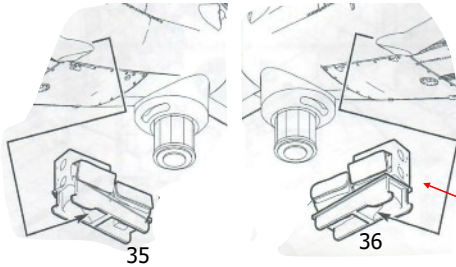

Painting: Main rotor hub is Dark Sea Grey



INSTRUCTIONS

- Remove any flash by gently snapping off, or cutting with a scalpel and then lightly sanding.
- Only use Super-glue or a two-part epoxy glue to fix parts.
- Gluing is easier if mating surfaces are slightly sanded to roughen the resin before gluing. Also clean off any dust before gluing.
- Before painting, thoroughly wash all parts in warm water with detergent.
- We recommend the application of a base coat in a light colour to show any blemishes prior to final painting.

WARNING & SAFETY!

- These parts are moulded in polyurethane resin. Please take care when sanding and cleaning up the resin by wearing a dust mask or other protective breathing device to avoid inhalation of the dust particles.
- Wash hands, resin parts and the work surface after sanding resin.
- When using Super-glue or two-part epoxy glue, please take precautions to avoid contact with skin and eyes.
- It is also advisable to wear a mask to avoid breathing in any fumes from the glue or work in a ventilated room.
- The use of barrier creams on hands or wearing disposable gloves, and working in a well-ventilated area, is strongly recommended.
- Not suitable for children under 14 years of age.

Thank you for purchasing this Air-Graphics product which forms part of a range of accessories, conversion sets, decals & kits all to 1/72 Scale.

Air-Graphics: 24 Fyfield Close, Wantage, Oxfordshire,
OX12 8HN, UK
E: gary.madgwick@air-graphics.co.uk
W: www.air-graphics.uk