



14556-0379

LEVEL 4  
1 2 3 4 5

# 2022 CORVETTE® STINGRAY Z51 COUPE

Beiliegenden Sicherheitstext beachten / Please note the enclosed safety advice

- Ⓢ Beiliegenden Sicherheitstext beachten und nachschlagbereit halten.
- Ⓢ Please note the enclosed safety advice and keep safe for later reference.
- Ⓢ Respecter les consignes de sécurité ci-jointes et les conserver à portée de main.
- Ⓢ Houdt u aan de bijgaande veiligheidsinstructies en hou deze steeds bij de hand.
- Ⓢ Seguire le avvertenze di sicurezza allegate e tenerle a portata di mano.
- Ⓢ Observar y siempre tener a disposición este texto de seguridad adjunto.
- Ⓢ Ter em atenção o texto de segurança anexo e guardá-lo para consulta.

- Ⓢ Overhold vedlagte sikkerhedsanvisninger og hav dem liggende i nærheden.
- Ⓢ Ha alltid vedlagt sikkerhetstekst klar til bruk.
- Ⓢ Beakta bifogad säkerhetstext och håll den i beredskap.
- Ⓢ Huomioi ja säilytä oheiset varoitukset.
- Ⓢ Соблюдать технику безопасности, сохранить инструкцию для дальнейших обращений.
- Ⓢ Przestrzegać załączonego tekstu dotyczącego bezpieczeństwa i mieć go zawsze pod ręką.
- Ⓢ Dodržujte tento příložený bezpečnostní text a mějte ho po ruce.
- Ⓢ A mellékelt biztonsági szöveget vegye figyelembe és tartsa fellepozásra készen.

- Ⓢ Respektujte přiložený bezpečnostní text a uchovajte ho pre budúce použitie.
- Ⓢ Respectați textul de siguranță atașat și păstrați-lă la îndemână.
- Ⓢ Спазвайте приложението текст за безопасност и го дръжте под ръка за справки.
- Ⓢ Priloga varnostna navodila izvajajte in jih hranite na vsem dostopnem mestu.
- Ⓢ Αββετευλόψη σας το συννημένο κείμενο ασφαλείας και φυλάξτε το ώστε να ανατρέχετε σε αυτό όποτε χρειάζεται.
- Ⓢ Ektekigüvenlik talimatlarını dikkate alıp, bakabileceğiniz bir şekilde muafaza ediniz.

© 2024 Carrera Revell Europe GmbH, Henschelstr. 20-30, D-32257 Bünde.

REVELL IS THE REGISTERED TRADEMARK OF CARRERA REVELL EUROPE GMBH, GERMANY. [www.revell.de](http://www.revell.de)



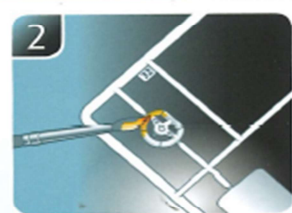
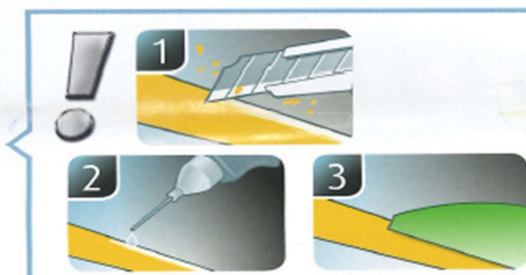
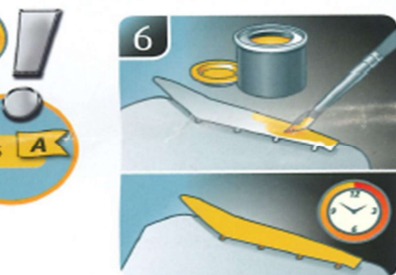
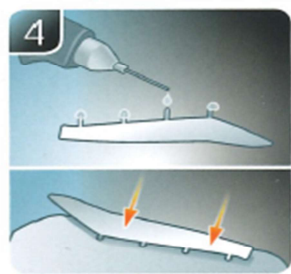
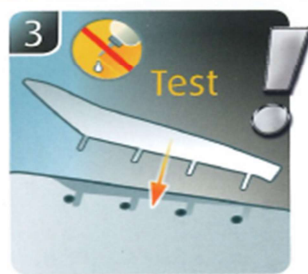
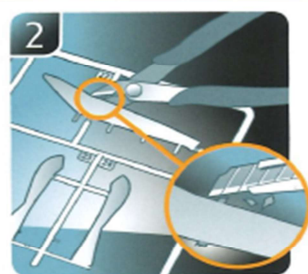
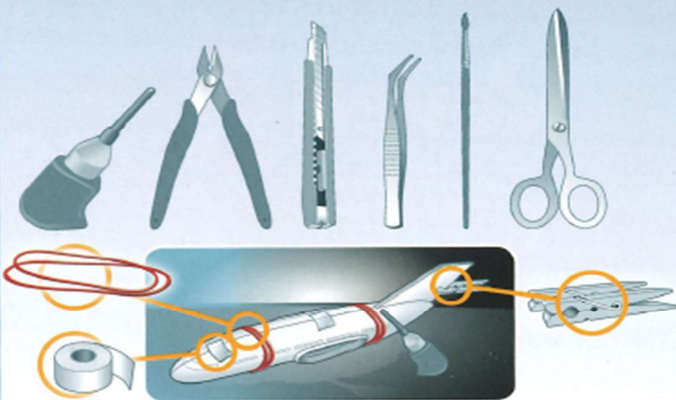

④ Weitere Tipps und Tricks.  
 ④ Additional tips and tricks.  
 ④ Conseils et astuces supplémentaires.  
 ④ Andere tips en trucs.  
 ④ Ulteriori consigli e suggerimenti.  
 ④ Consejos y sugerencias adicionales.  
 ④ Mais dicas e truques.

④ Flere tips og tricks.  
 ④ Flere tips og tricks.  
 ④ Ytterligare tips och tricks.  
 ④ Lisää vinkkejä ja niksejä.  
 ④ Другие советы и хитрости.  
 ④ Dalsze wskazówki i sugestie.  
 ④ Další tipy a rady.  
 ④ További ötletek és fogások.  
 ④ Dalsie tipy a triky.  
 ④ Alte sfaturi și trucuri.

④ Други полезни съвети и трикове.  
 ④ Nadaljnji nasveti in zvijače.  
 ④ Προσθετες συμβουλές και κόλποι.  
 ④ Diger öneriler ve ipuçları.

[www.revell.de](http://www.revell.de)



Glue  
Coller  
Pegamento



Don't glue  
Ne pas coller  
No pegamento



Paint  
Peindre  
Pintar



Number of working steps.  
Nombre d'étapes de travail.  
Número de pasos de trabajo.



Optional  
Facultatif  
Opcional



Attention  
Attention  
Atención



Repeat same procedure on opposite side.  
Opérer de la même façon sur l'autre face.  
Repetir el mismo procedimiento en el lado contrario.



Read the assembly instructions carefully.  
Lisez attentivement les instructions de montage.  
Lea cuidadosamente las instrucciones de montaje.



Sequence of assembly.  
Ordre d'assemblage.  
Secuencia de montaje.



Illustration of assembled parts.  
Figure représentant les pièces assemblées.  
Figura de las piezas montadas.



Clear parts  
Pièces transparentes  
Piezas transparentes



Soak and apply decals.  
Mouiller et appliquer les décalcomanies.  
Mojar y aplicar calcomanías.



Make a hole.  
Faire un trou.  
Hacer un agujero.



Detach with knife.  
Détacher au couteau.  
Separar con cuchillo.



Remove  
Détacher  
Eliminar



Recommended to fix clear parts.  
Recommandé pour fixer les pièces transparentes.  
Recomendado para fijar las piezas transparentes.



Recommended for affixing the decals.  
Recommandé pour l'application des décalcomanies.  
Recomendado para fijar bien las calcomanías.

\* Not included  
Non fourni  
No incluido



## Required colours

- Peintures nécessaires
- Colores necesarios

07

A

- Black gloss
- Noir brillant
- Negro brillante

08

B

- Black matt
- Noir mat
- Negro mate

09

C

- Anthracite matt
- Anthracite mat
- Antracita mate

31

D

- Fiery red gloss
- Rouge feu brillant
- Rojo fuego brillante

50

E

- Light blue gloss
- Bleu clair brillant
- Azul claro brillante

90

F

- Silver metallic
- Argent métallique
- Plata metálico

91

G

- Iron metallic
- Fer métallique
- Acero metálico

99

H

- Aluminium metallic
- Aluminium métallique
- Aluminio metálico

730

I

- Orange clear
- Orange clair
- Naranja claro

731

J

- Red clear
- Rouge clair
- Rojo claro

302

K

- Black silk matt
- Noir satiné mat
- Negro mate satinado

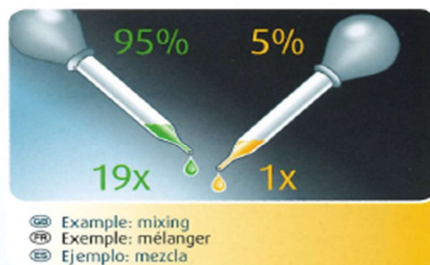



PART TREE	#	PART NAME	NOM DE PIÈCE	NOMBRE DE LA PIEZA
	1	Body	Carrosserie	Cuerpo
A	39	Rt. Front Radiator	Radiateur avant droit	Radiador delantero derecho
A	40	Lt. Front Radiator	Radiateur avant gauche	Radiador delantero izquierdo
A	81	Dashboard	Tableau de bord	Tablero
A	114	Oil Tank Back	Arrière de réservoir d'huile	Parte trasera del tanque de aceite
A	115	Lt. Cylinder Head	Culasse gauche	Tapa del cilindro izquierda
A	116	Rt. Cylinder Head	Culasse droite	Tapa del cilindro derecha
A	117	Valve Cover	Couvercle de soupape	tapa de la valvula
A	121	Belt Assembly	Assemblage de courroie	Ensamblaje del cinturón
A	123	Starter	Démarrreur	Arranque
A	124	Oil Filter	Filtre à huile	Filtro de aceite
A	137	Air Filter Rear Half	Filtre à air moitie arriere	Mitad trasera del filtro de aire
A	147	Dashboard Top - LHD	Dessus du tableau de bord - LHD	Parte superior del tablero - LHD
B	37	Lt. Intake Vent	Prise d'air gauche	Ventilacion de entrada izquierda
B	38	Rt. Intake Vent	Prise d'air droit	Ventilacion de entrada derecha
B	54	Lt. Front Lower A-Arm Cover	Couvercle du bras triangulaire inferieur avant gauche	Cubierta del brazo A inferior delantero izquierdo
B	55	Rt. Front Lower A-Arm Cover	Couvercle du bras triangulaire inferieur avant droit	Cubierta del brazo A inferior delantero derecho
B	57	Rt. Front Shock	Amortisseur avant droit	Amortiguador delantero derecho
B	64	Lt. Rear Bumper Grille Vent	Grille d'aeration de pare-chocs arriere gauche	Ventilacion de rejilla del parachoques trasero izquierdo
B	65	Rt. Rear Bumper Grille Vent	Grille d'aeration de pare-chocs arriere droit	Ventilacion de rejilla del parachoques trasero derecho
B	75	Front License Plate - USA Spec	Plaque d'immatriculation avant - Etats-Unis	Placa de matricula delantera - EE.UU
B	77	Lt. Rear Shock	Amortisseur arriere gauche	Amortiguador trasero izquierdo
B	78	Rt. Rear Shock	Amortisseur arriere droit	Amortiguador trasero derecho
B	79	Lt. Front Shock	Amortisseur avant gauche	Amortiguador delantero izquierdo
B	82	Dashboard Top - RHD	Dessus du tableau de bord - RHD	Parte superior del tablero - RHD
B	83	Steering Wheel	Volant	Volante de dirección
B	99	Center Speaker	Haut-parleur central	Orador central
B	110	Transmission Cover Rear	Couvercle de transmission	Cubierta de la transmisión
B	113	Transmission Bottom	Bas de transmission	Parte inferior de la transmisión
B	119	Intake Manifold	Collecteur d'admission	Colector de admisión
B	130	Rt. Exhaust Top Half	Haut d'échappement droit	Parte superior de escape derecha
B	131	Lt. Exhaust Bottom Half	Bas d'échappement gauche	Parte inferior del escape izquierdo
B	132	Rt. Exhaust Bottom Half	Bas d'échappement droit	Fondo de escape derecho
B	133	Lt. Exhaust Top Half	Haut d'échappement gauche	Escape superior izquierdo
B	136	Exhaust	Échappement	Tubo de escape
B	138	Air Cleaner Front Half	Moitie avant du filtre a air	Mitad delantera del filtro de aire
B	139	Oil Cooler	Refrigerateur d'huile	Refrigerador de aceite
B	140	Lt. Exhaust Heat Shield	Bouclier d'échappement gauche	Escudo de escape izquierdo
B	141	Rt. Exhaust Heat Shield	Bouclier d'échappement droit	Escudo de escape derecho
B	148	Dashboard Upper Trim - RHD	Dessus du tableau de bord - RHD	Parte superior del tablero - RHD
C	12	Lt. Mirror Housing	Châssis du miroir gauche	Carcasa del retrovisor izquierdo
C	13	Rt. Mirror Housing	Châssis du miroir droit	Carcasa del retrovisor derecho
C	14	Cowl	Capot	Cubierta
C	49	Visor Panel	Panneau de visière	Panel de visera
C	59	Lt. Front Wheel Knuckle	Fusee de roue avant gauche	Articulacion de la rueda delantera izquierda
C	60	Rt. Front Wheel Knuckle	Fusee de roue avant droit	Articulacion de la rueda delantera derecha
C	63	Inner Wheel Retainer	Support de roue interieur	Retenedor de rueda interior
C	74	Front License Plate Holder - Euro Spec	Cadre de plaque d'immatriculation avant - L'Europe	Marco de matricula frontal - Europa
C	76	Front Splitter	Divisor frontal	Separateur avant
C	80	Rt. Windshield Wiper - RHD	Essuie-glace droit - RHD	Limpiaparabrisas derecho - RHD
C	85	Steering Column	Colonne de direction	Columna de dirección
C	111	Fuel Feed Panel	Panneau d'alimentation en carburant	Panel de alimentacion de combustible
C	122	Alternator	Alternateur	Alternador
C	125	Lt. Engine Mount	Montage gauche du moteur	Montaje del motor izquierdo
C	126	Lt. Upper Exhaust Manifold	Collecteur d'échappement supérieur gauche	Colector superior del escape izquierdo
C	127	Lt. Lower Exhaust Manifold	Collecteur d'échappement inférieur gauche	Colector inferior del escape izquierdo
C	128	Rt. Upper Exhaust Manifold	Collecteur d'échappement supérieur droit	Colector superior del escape derecho
C	129	Rt. Lower Exhaust Manifold	Collecteur d'échappement inférieur droit	Colector inferior del escape derecho
C	134	Lt. Rear Driveshaft	Arbre de transmission arriere gauche	Eje de transmision trasero izquierdo
C	135	Rt. Rear Driveshaft	Arbre de transmission arriere droit	Eje de transmision trasero derecho
C	144	Lt. Windshield Wiper - RHD	Essuie-glace gauche - RHD	Limpiaparabrisas izquierdo - RHD
C	145	Rt. Windshield Wiper - LHD	Essuie-glace droit - LHD	Limpiaparabrisas derecho - LHD
C	156	Lt. Windshield Wiper - LHD	Essuie-glace gauche - LHD	Limpiaparabrisas izquierdo - LHD
C	157	Paddle Shifter	Manettes d'embrayage	Palanca de cambios
C	158	Rt. Engine Mount	Montage droit du moteur	Montaje del motor derecho
E	42	Rt. Headlight Panel	Panneau de phares avant droit	Panel de faros derechos



PART TREE	#	PART NAME	NOM DE PIÈCE	NOMBRE DE LA PIEZA
E	43	Lt. Taillight Molding	Moulage de feu arrière gauche	Moldeado de la luz trasera izquierda
E	44	Rt. Taillight Panel	Panneau de feu arrière droit	Panel de la luz trasera derecha
E	45	Lt. Mirror	Miroir gauche	Retrovisor izquierdo
E	47	Lt. Exhaust Tips	Pointes d'échappement gauche	Puntas del tubo de escape izquierdo
E	48	Rt. Exhaust Tips	Pointes d'échappement droit	Puntas del tubo de escape derecho
E	154	Rt. Mirror	Miroir droit	Retrovisor derecho
E	155	Lt. Headlight Panel	Panneau de phares avant gauche	Panel de faros izquierdos
F	68	Front Wheel	Roue avant	Rueda delantera
F	69	Rear Wheel	Roue arrière	Rueda trasera
G	8	Roof Panel	Panneau de toit	Panel del techo
G	41	Rear Hatch	Clapet arrière	Compuerta trasera
G	97	Rear Window Frame	Encadrement de glace arrière	Marco de ventana trasera
G	120	Engine Cover	Couvercle de moteur	Cubierta del motor
G	149	Roof Panel	Panneau de toit	Panel del techo
I	31	Chassis	Châssis	Chasis
I	32	Lt. Front Inner Fender	Aile interne avant gauche	Guardafangos internos delanteros izquierdos
I	33	Rt. Front Inner Fender	Aile interne avant droit	Guardafangos internos delanteros derechos
I	34	Lt. Rear Inner Fender	Aile arrière interne gauche	Guardabarros interno trasero izquierdo
I	35	Rt. Rear Inner Fender	Aile arrière interne droite	Guardabarros interno trasero derecho
I	70	Lt. Rear Wheel Knuckle	Articulation de la roue trasera droite	Articulacion de la rueda trasera izquierdo
I	71	Rt. Rear Wheel Knuckle	Fusee de roue arrière droit	Articulacion de la rueda trasera derecha
I	109	Oil Tank Front	Avant du réservoir d'huile	Parte delantera del tanque de aceite
J	4	Rear Bumper	Pare-chocs arrière	Parachoques trasero
J	46	Rear View Mirror	Rétroviseur	Espejo retrovisor trasero
J	52	Rt. Rear Upper A-Arm	Bras en A supérieur arrière droit	Brazo en A trasero derecho
J	53	Lt. Rear Upper A-Arm	Bras en A supérieur arrière gauche	Brazo en A trasero izquierdo
J	58	Front Axle	Essieu avant	Eje delantero
J	86	Interior	Intérieur	Interior
J	89	Rt. Interior Panel	Panneau intérieur droit	Panel interior derecho
J	90	Lt. Interior Panel	Panneau intérieur gauche	Panel interior izquierdo
J	95	Rt. Seat Back	Siège arrière droit	Respaldo de asiento derecho
J	96	Lt. Seat Back	Siège arrière gauche	Respaldo de asiento izquierdo
J	107	Lt. Engine Half	Moitié gauche du moteur	Mitad izquierda del motor
J	108	Rt. Engine Half	Moitié droite du moteur	Mitad derecha del motor
L	5	Rt. Body Intake Inner	Admission du corps droit interieure	Entrada interior del cuerpo derecho
L	6	Lt. Body Intake Inner	Admission du corps gauche interieure	Entrada interior del cuerpo izquierdo
L	10	Lt. Body Trim	Garniture de carrosserie gauche	Moldura de carrocería izquierda
L	11	Rt. Body Trim	Garniture de carrosserie droite	Moldura de carrocería derecha
L	36	Grille	Grille	Parrilla
L	50	Rt. Front Upper A-Arm	Bras en A supérieur avant droit	Brazo en A superior delantero derecho
L	51	Lt. Front Upper A-Arm	Bras en A supérieur avant gauche	Brazo en A superior delantero izquierdo
L	61	Rt. Front Rotor	Disque de frein avant droit	Rotor de freno delantero derecho
L	62	Lt. Front Rotor	Disque de frein avant gauche	Rotor de freno delantero izquierdo
L	72	Rt. Rear Rotor	Disque de frein arrière droit	Rotor de freno trasero derecho
L	73	Lt. Rear Rotor	Disque de frein arrière gauche	Rotor de freno trasero izquierdo
L	88	Center Console - RHD	Console centrale - RHD	Consola central - RHD
L	104	Rear License Plate - Euro Spec	Plaque arrière - L'Europe	Placa de licencia trasera - Europa
L	105	Rear License Plate - USA Spec	Plaque arrière - Etats-Unis	Placa de licencia trasera - EE.UU
L	159	Center Console - LHD	Console centrale - LHD	Consola central - LHD
M	91	Rt. Front Seat	Siège avant droit	Asiento delantero derecho
M	92	Lt. Front Seat	Siège avant gauche	Asiento delantero izquierdo
M	103	Rear Spoiler	Défecteur arrière	Alerón trasero
N	20	Lt. B-Pillar Panel	Panneau du montant B gauche	Panel del pilar B izquierdo
N	21	Rt. B-Pillar Panel	Panneau du montant B droit	Panel del pilar B derecho
N	24	Rear Window	Vitre arrière	Ventana trasera
N	25	Rear Windshield	Pare-brise arrière	Parabrisas posterior
P	15	Lt. Headlight Lens	Lentille de phare gauche	Lente de la luz delantera izquierda
P	16	Rt. Headlight Lens	Lentille de phare droit	Lente de la luz delantera derecha
P	17	Windshield	Pare-brise	Parabrisas
P	18	Lt. Window	Fentetre de gauche	Ventana izquierda
P	19	Rt. Window	Fentetre de droit	Ventana derecha
P	27	Lt. Taillight	Feu arrière gauche	Luz trasera izquierda
P	28	Rt. Taillight	Feu arrière droit	Luz trasera derecha
T	29	Front Tire	Pneu avant	Neumático delantero
T	30	Rear Tire	Pneu arrière	Neumático trasero



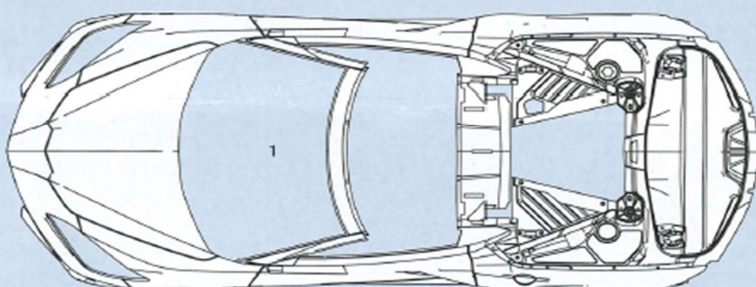
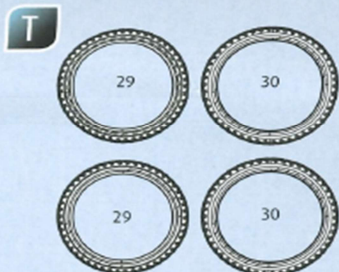
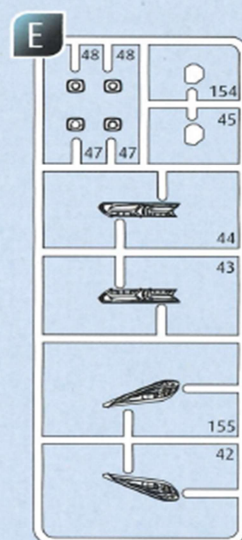
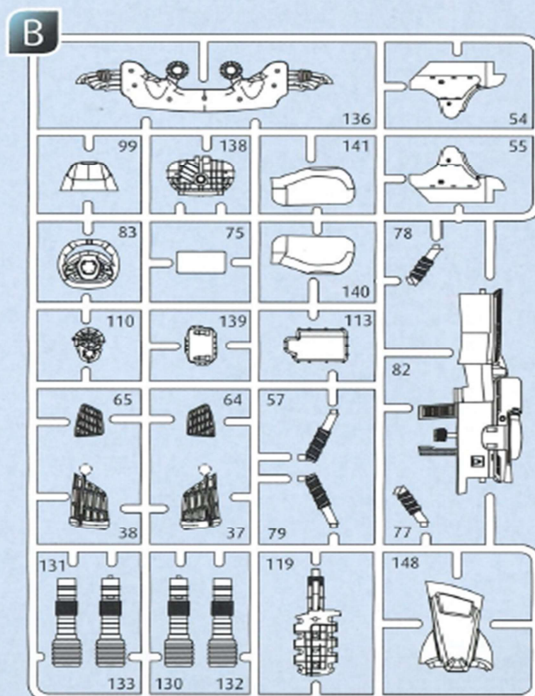
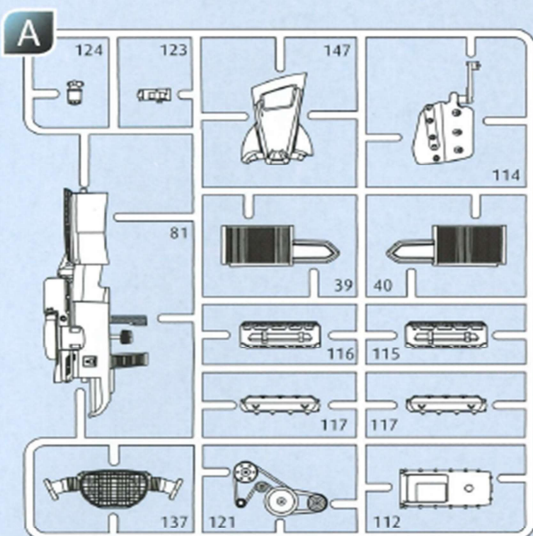

- ⊖ Parts not used.
- ⊖ Pièces non utilisées.
- ⊖ Piezas no utilizadas

## CUSTOMER SERVICE

If you have questions or problems visit our parts replacement website [www.revell-service.de](http://www.revell-service.de) or write to us at:

**Carrera Revell of Americas, Inc.  
Consumer Service  
197 Route 18 South, Suite 307N  
East Brunswick, NJ 08816**

Be sure to include this plan number (14556-0379), part number, description and your return address and phone number.

## SERVICE CLIENTÈLE

Si vous avez des questions ou des problèmes, visitez notre site Web de remplacement de pièces [www.revell-service.de](http://www.revell-service.de) ou écrivez-nous à:

**Carrera Revell of Americas, Inc.  
Consumer Service  
197 Route 18 South, Suite 307N  
East Brunswick, NJ 08816**

Veillez à inclure ce numéro de plan (14552-0389), le numéro de pièce, la description de la pièce, votre adresse de retour et votre numéro de téléphone.

## ATENCIÓN AL CLIENTE

Si tiene preguntas o problemas, visite nuestro sitio web de reemplazo de piezas [www.revell-service.de](http://www.revell-service.de) o escríbanos a:

**Carrera Revell of Americas, Inc.  
Consumer Service  
197 Route 18 South, Suite 307N  
East Brunswick, NJ 08816**

Asegúrese de incluir el número de plan (14556-0379), número de pieza, descripción, y su dirección postal y número de teléfono.



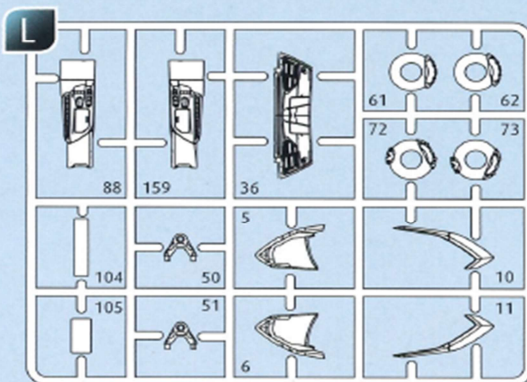
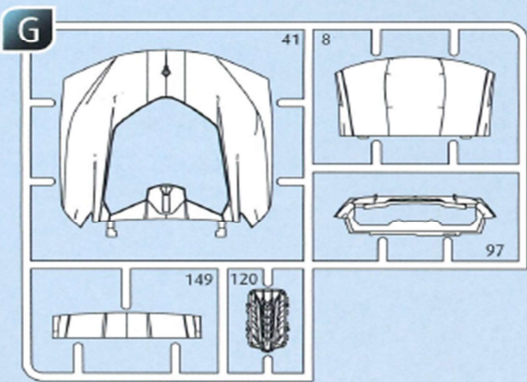
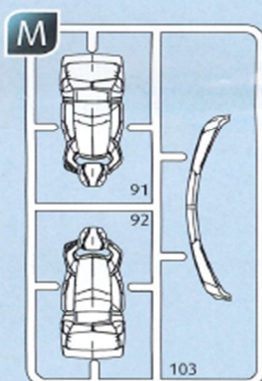
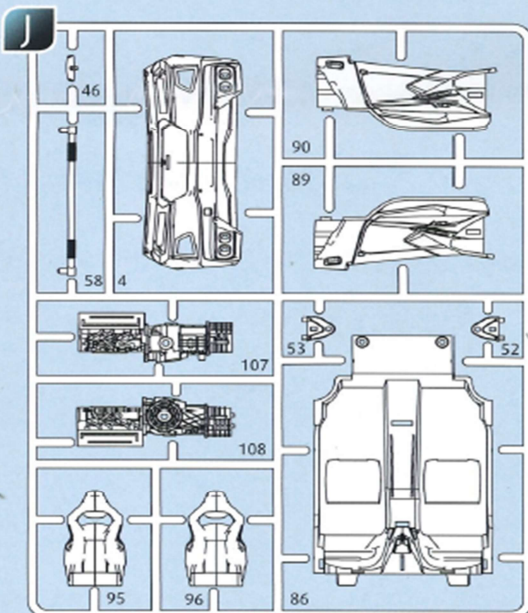
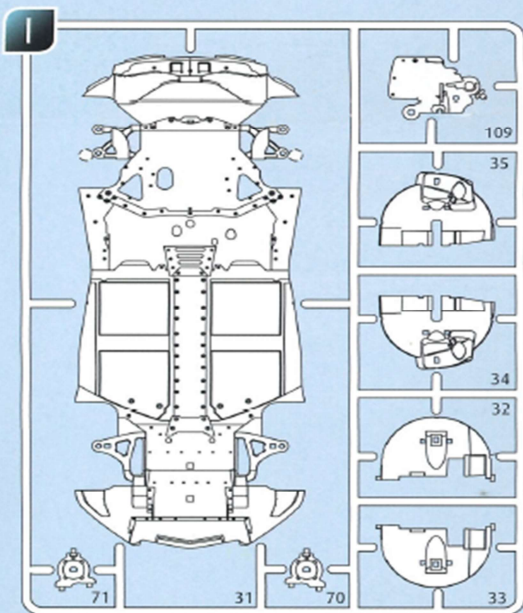
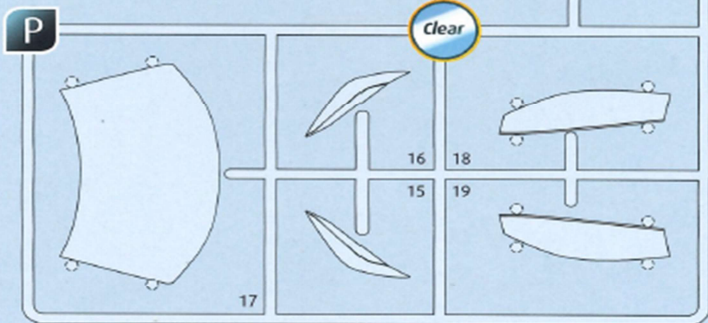
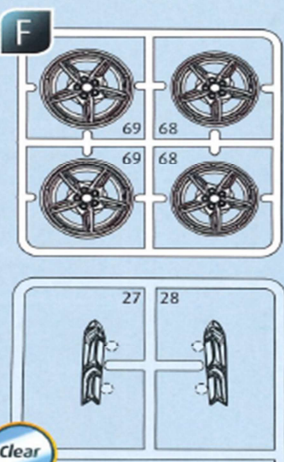
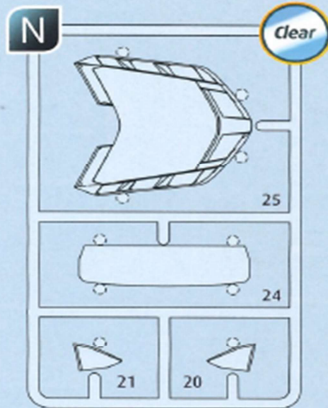
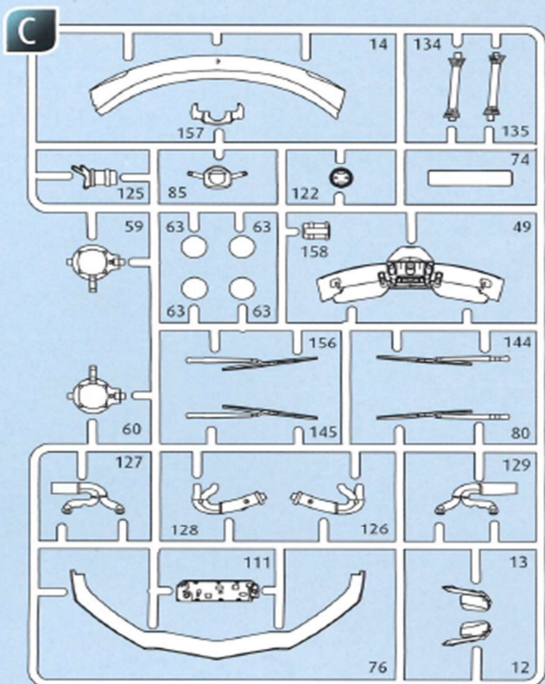



1  

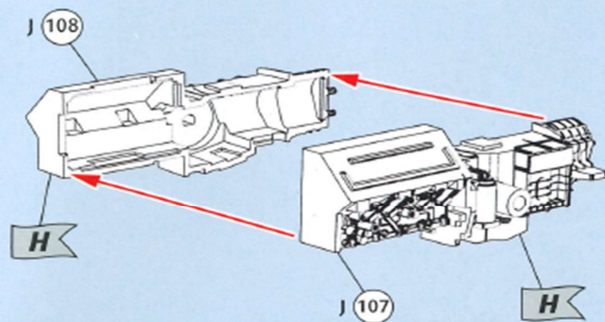

2  

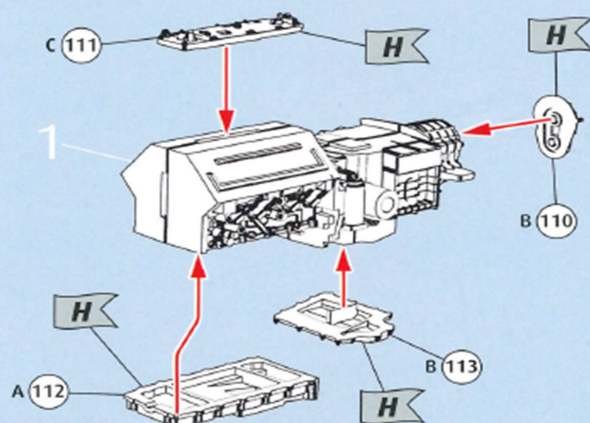

3  

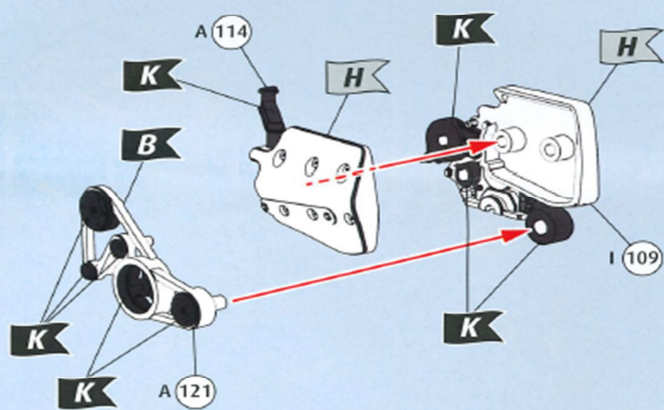

4  

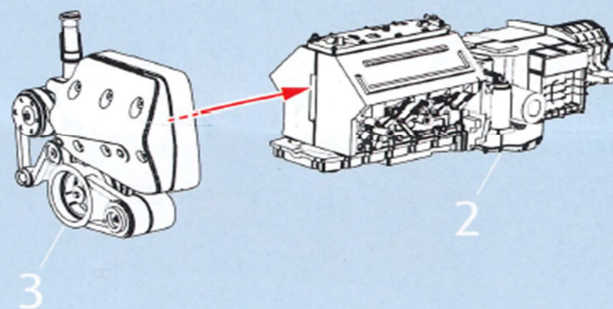

5    

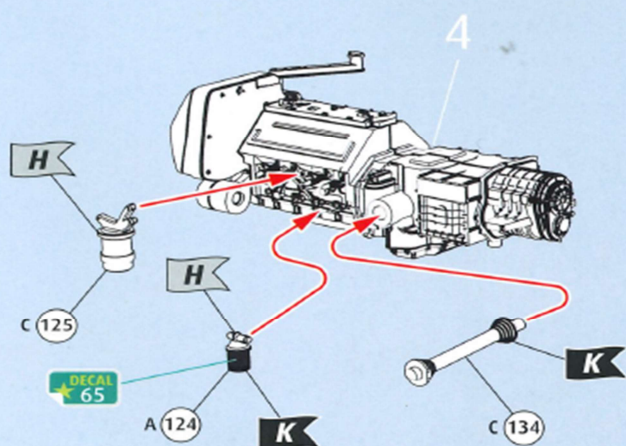

6  

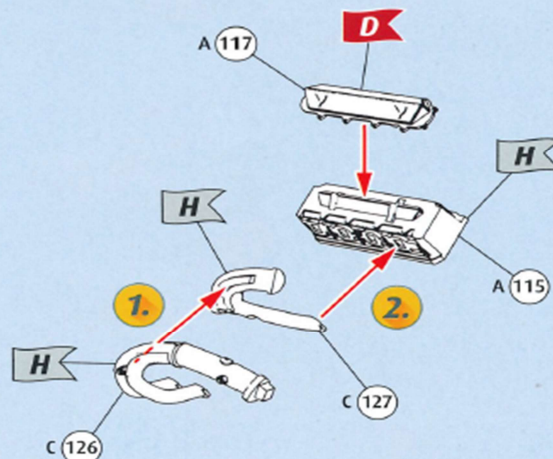



7  

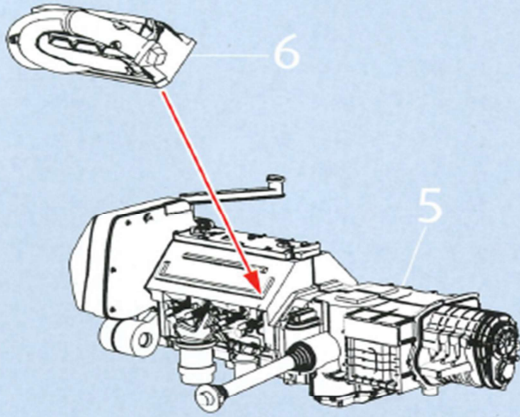

8  

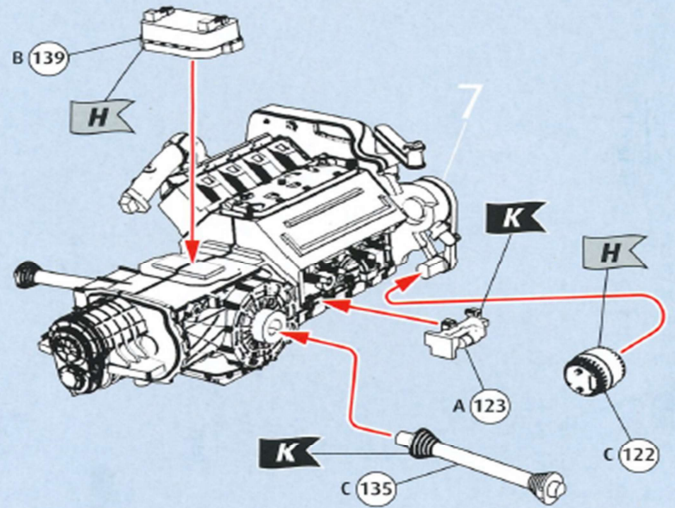

9  

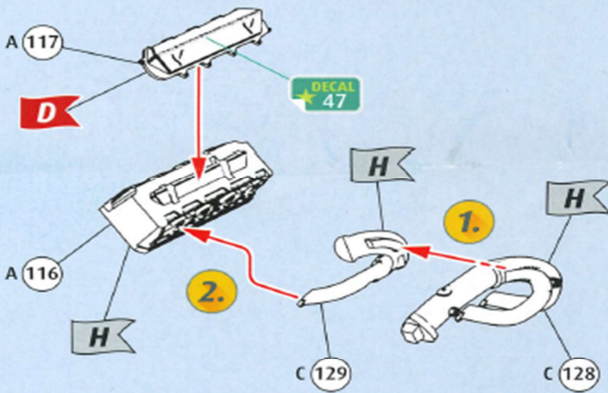

10  

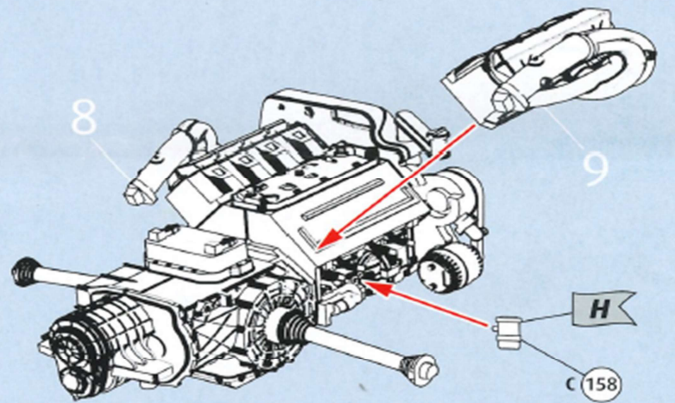

11    

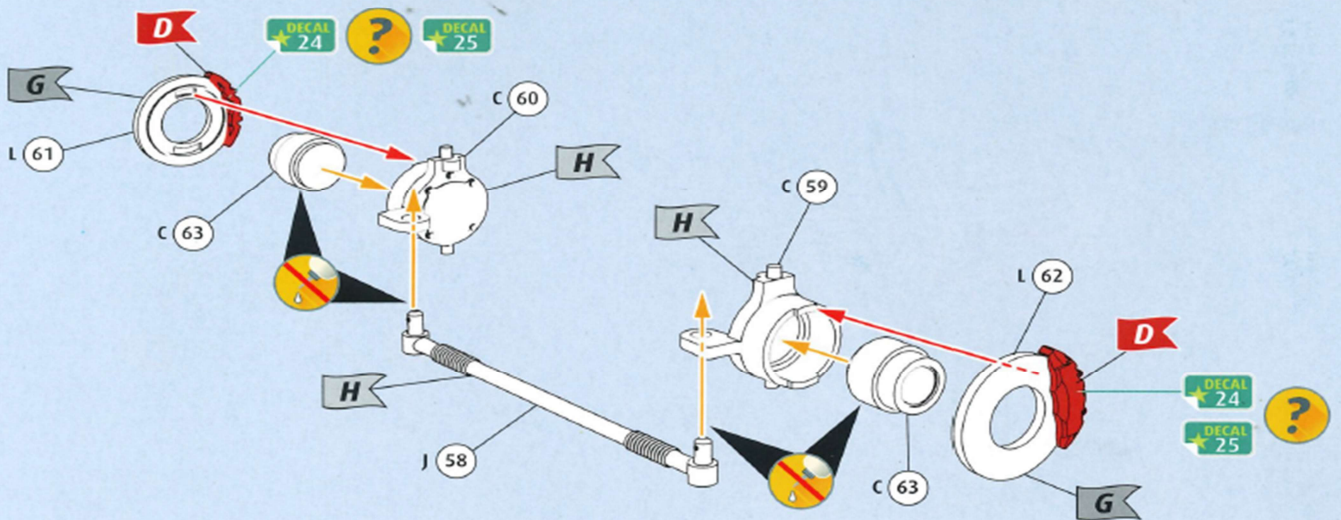



12  

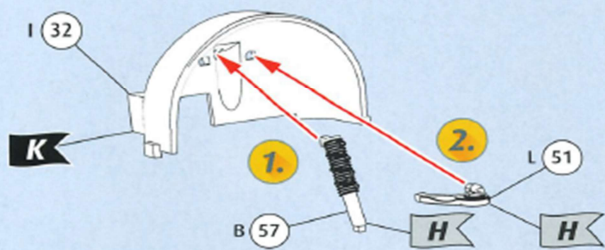

13  

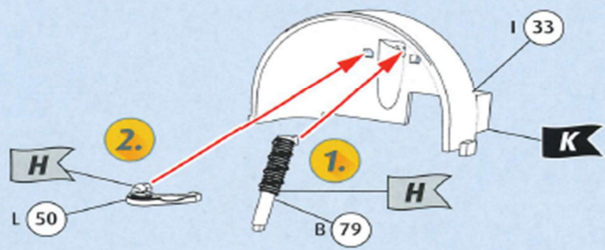

14  

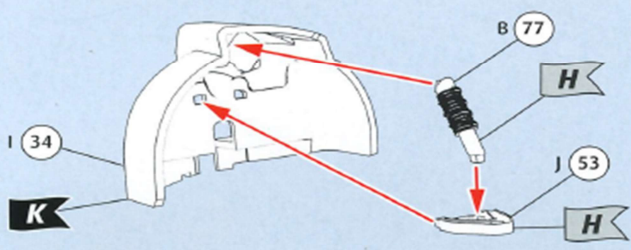

15  

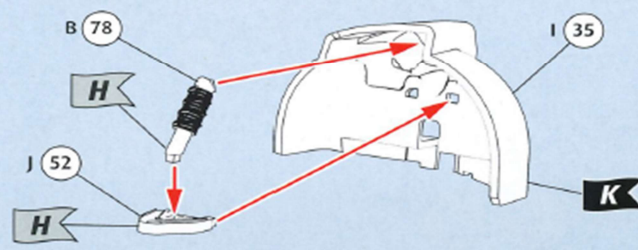

16  

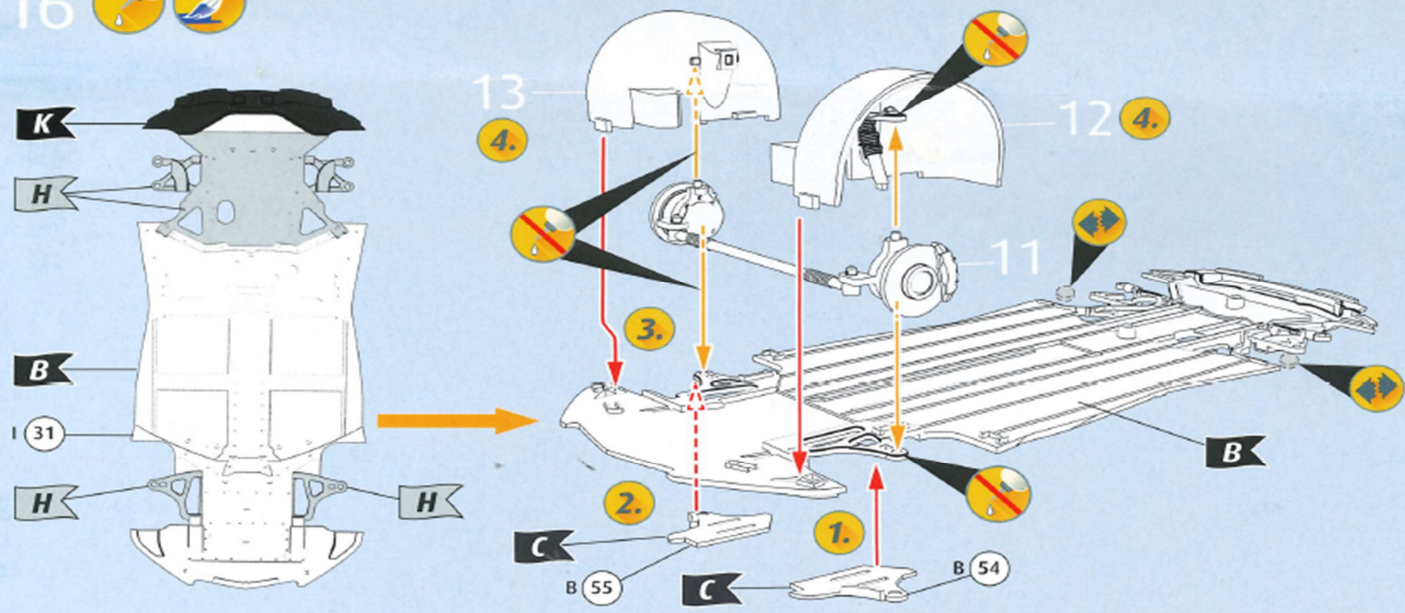

17   

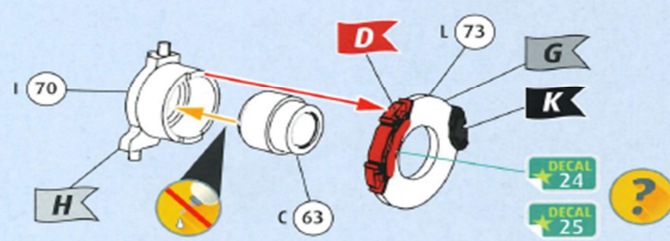

18   

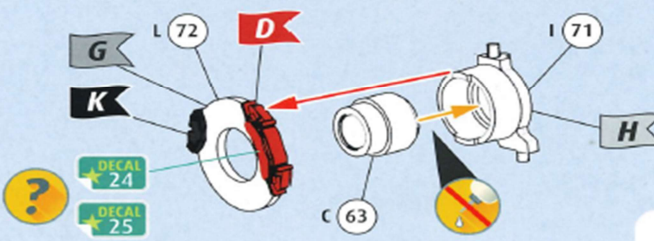







25

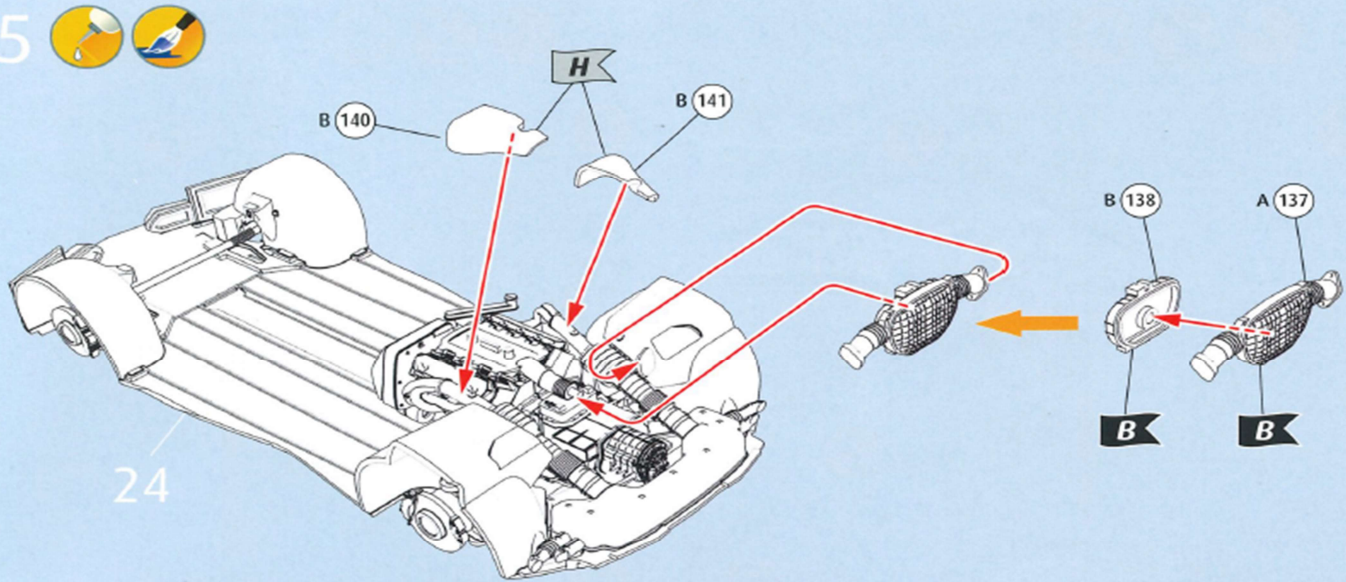

26

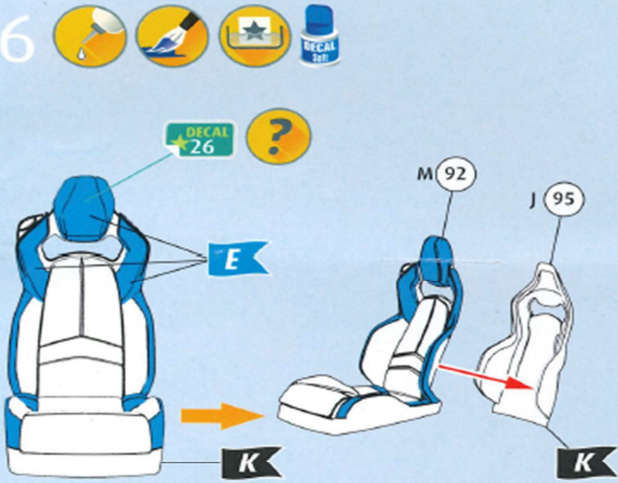

27

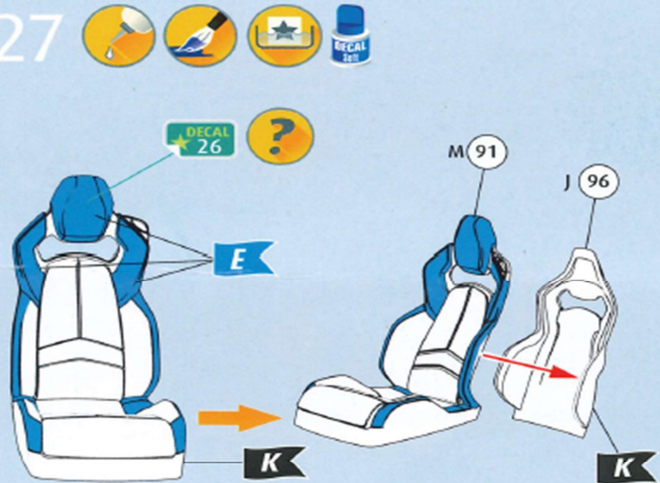

28

! Left Hand Drive

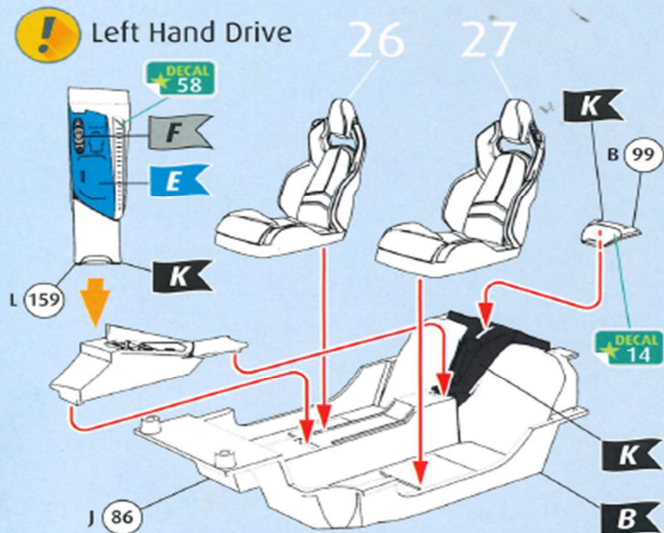

29

! Right Hand Drive

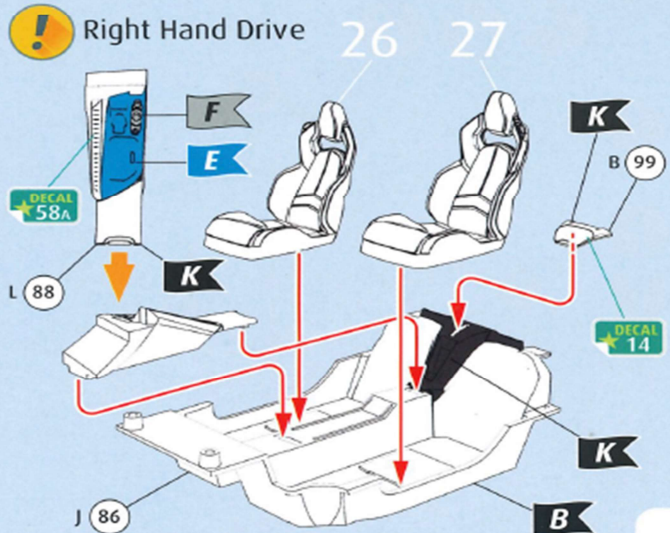



30



**!** Left Hand Drive

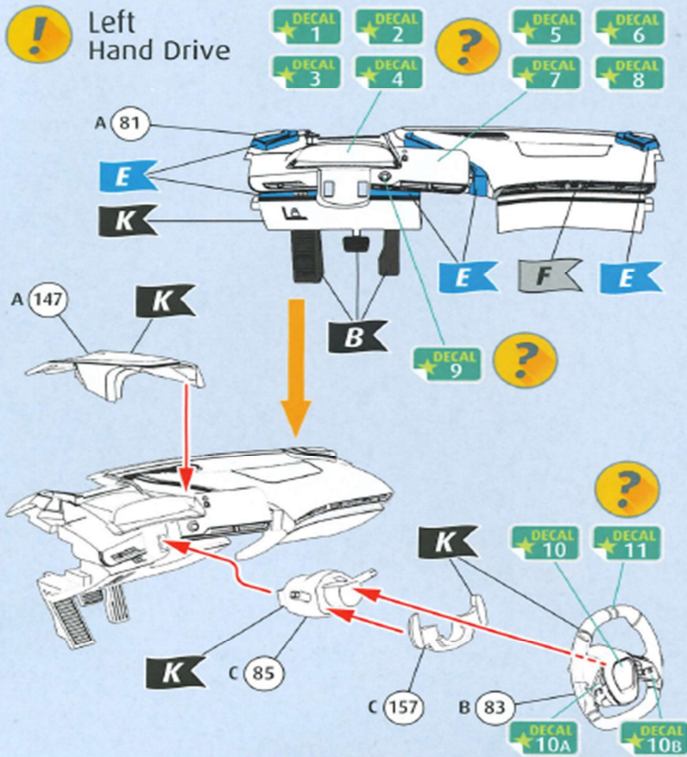

31



**!** Right Hand Drive

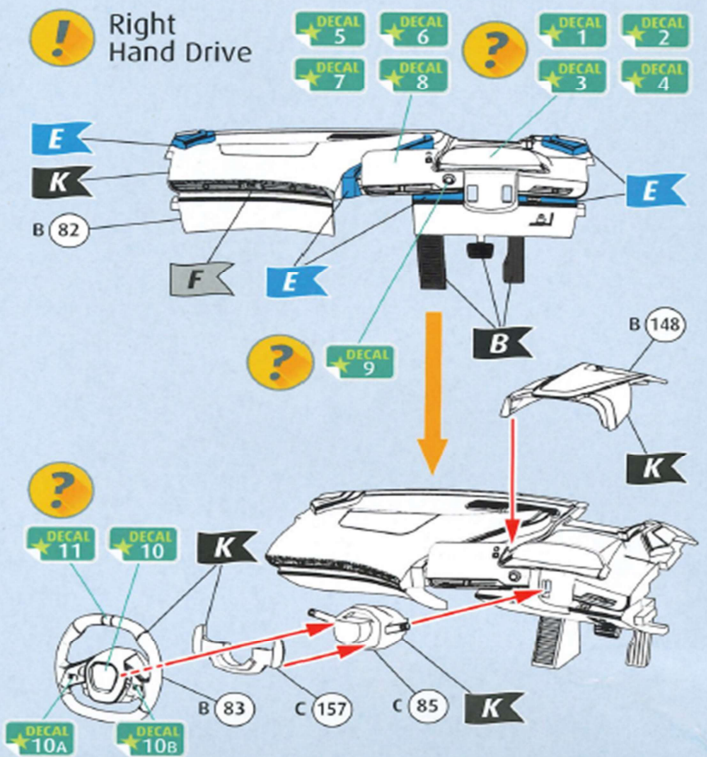

32



**!** Right Hand Drive  
**!** Left Hand Drive

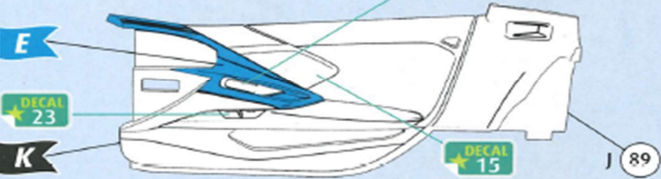

33



**!** Right Hand Drive  
**!** Left Hand Drive

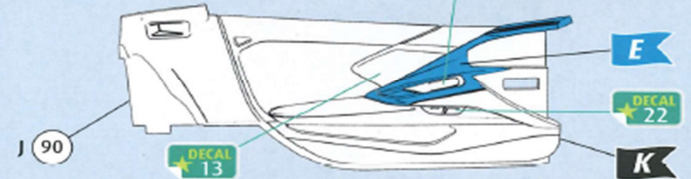

34



**!** Left Hand Drive

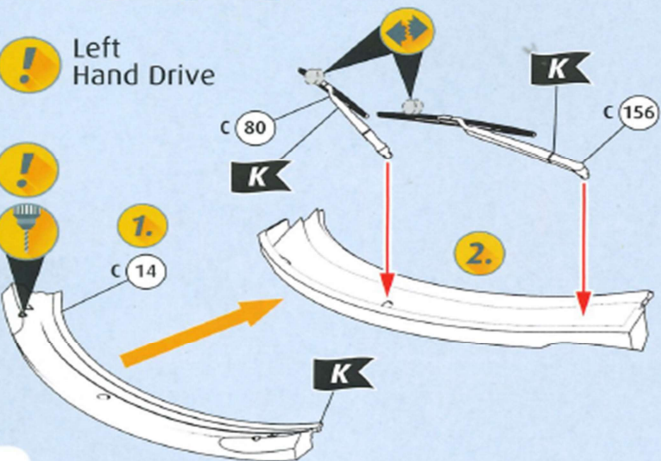

35



**!** Right Hand Drive

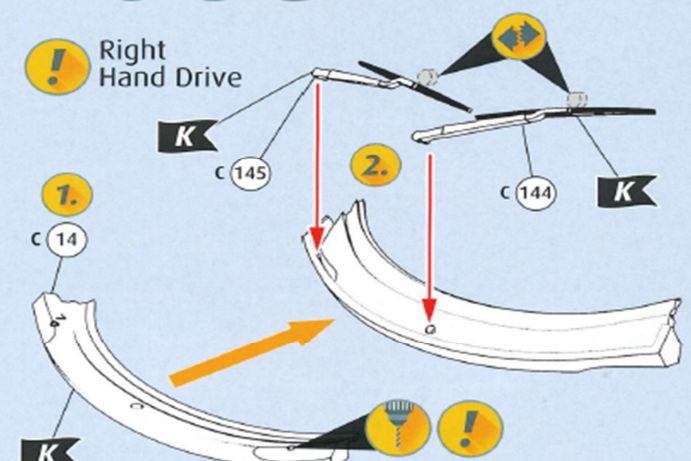



36 

 Left Hand Drive

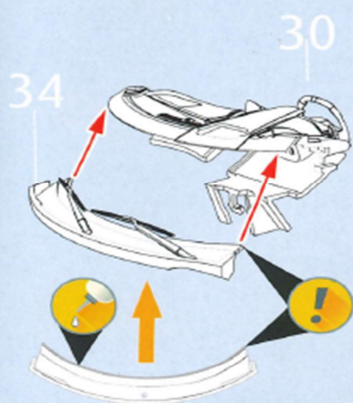

37 

 Left Hand Drive

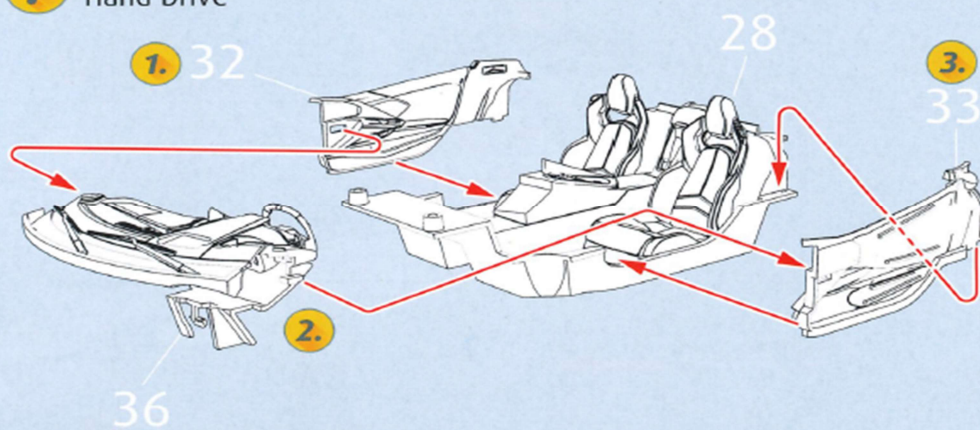

38 

 Right Hand Drive

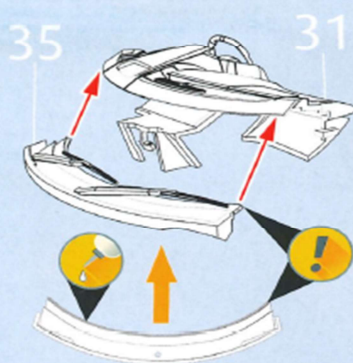

39 

 Right Hand Drive

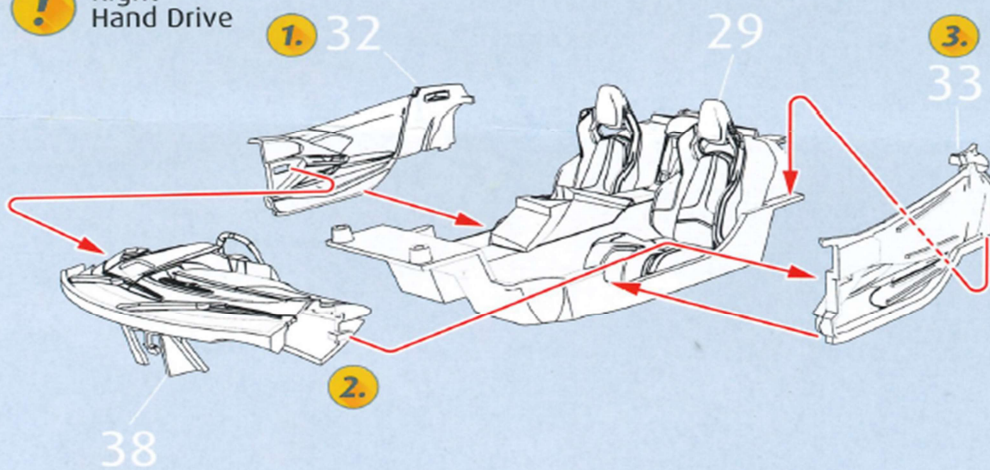

40 

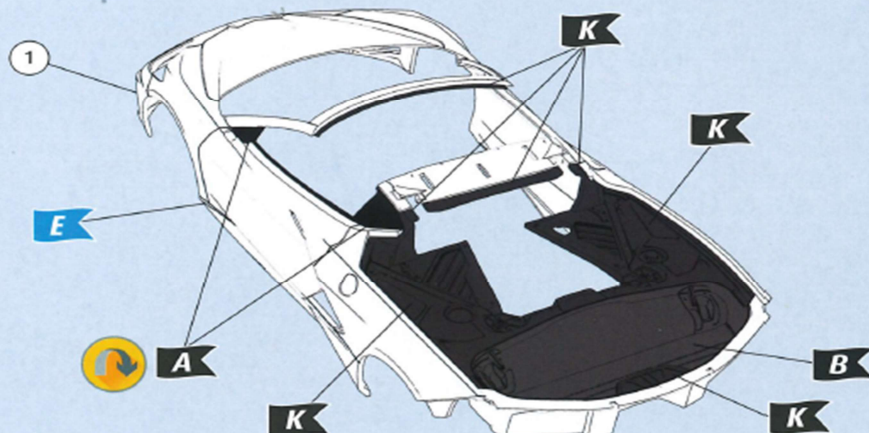



41

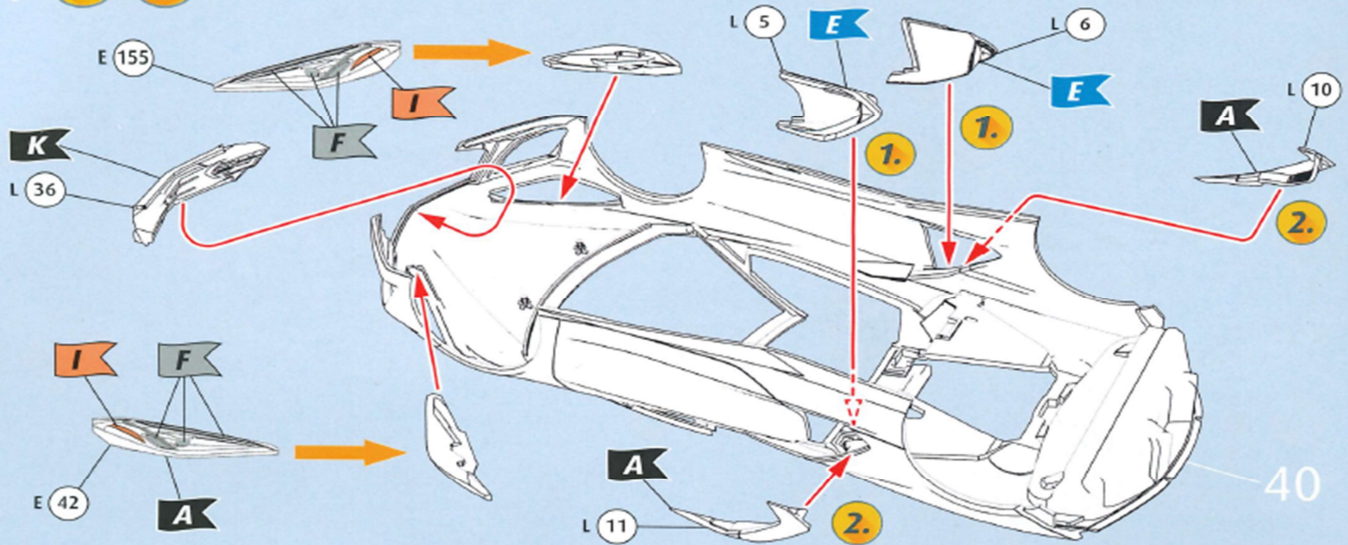

42

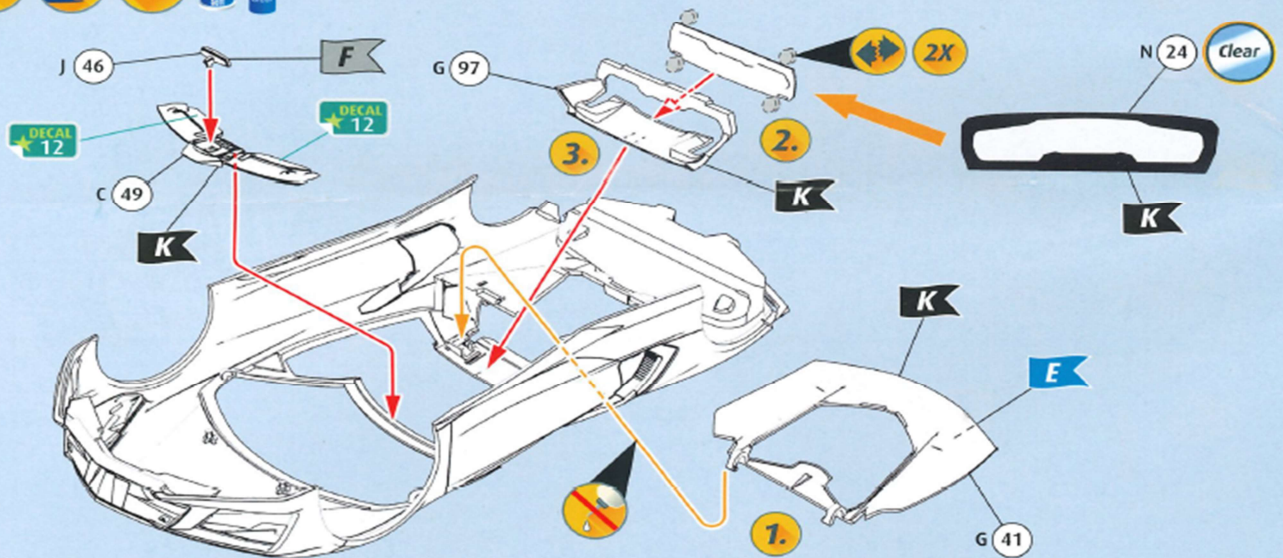

43



Left  
Hand Drive  
37  
?  
39  
Right  
Hand Drive

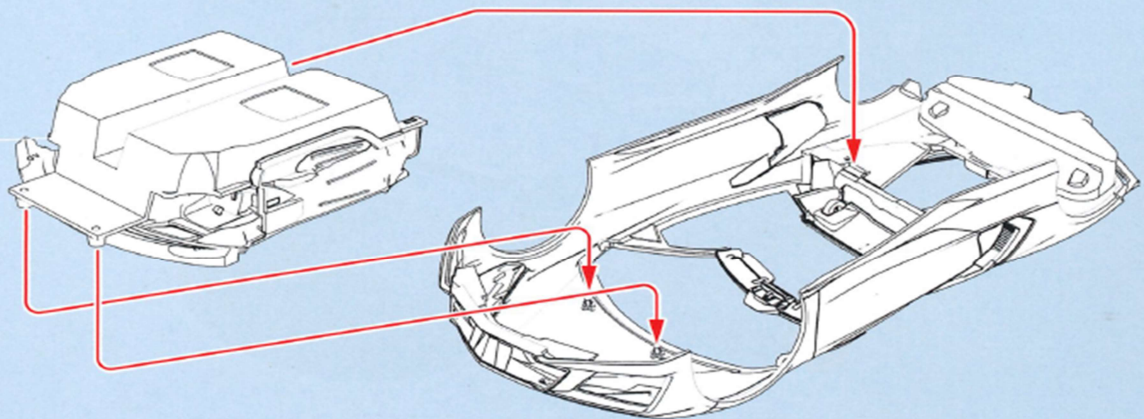



44 

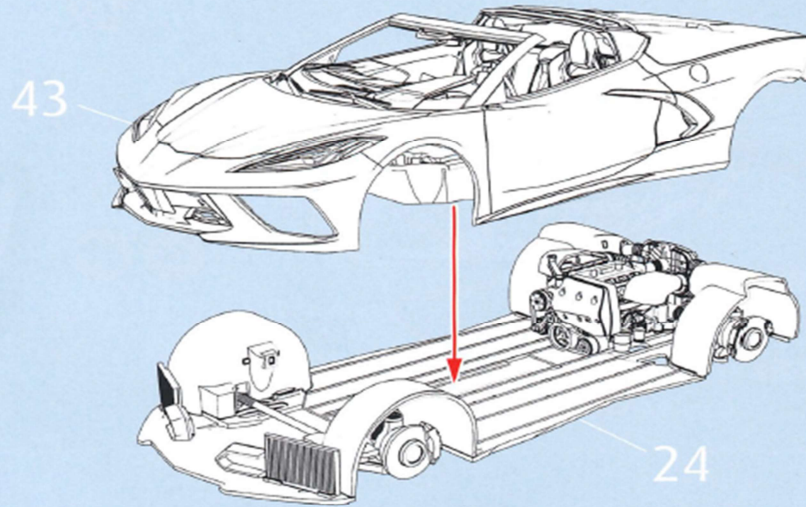

45 

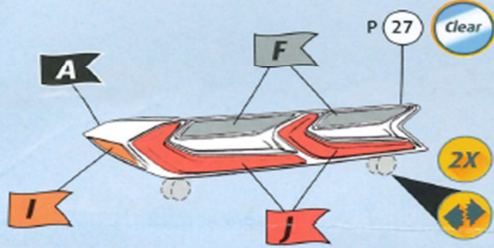

46 

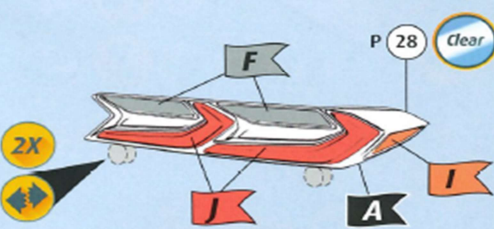

47     

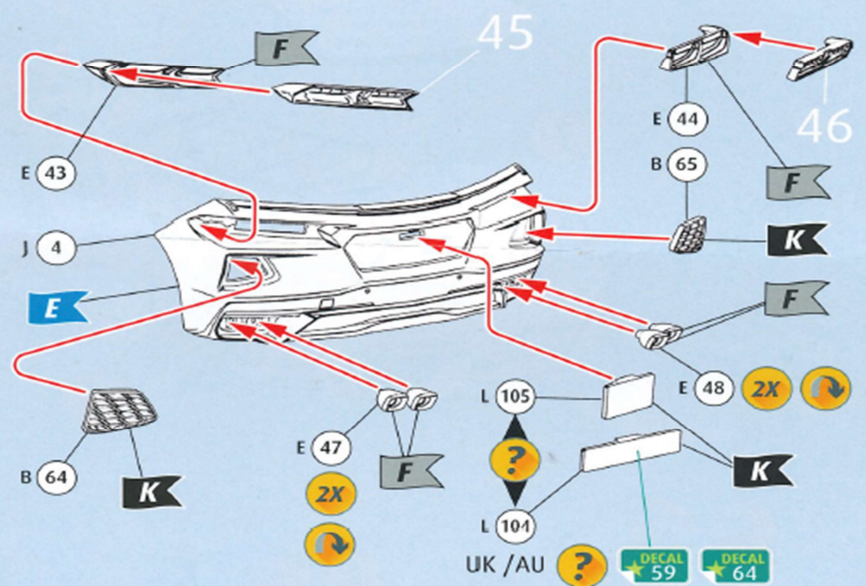

48 

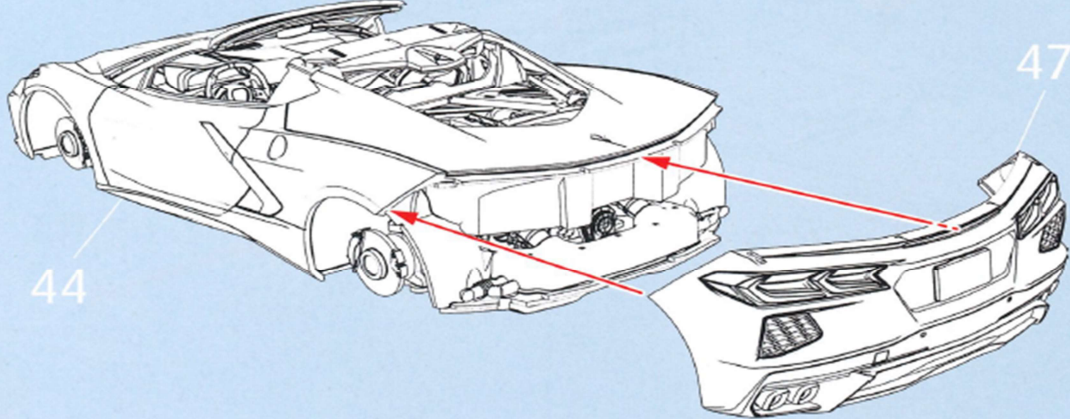



49

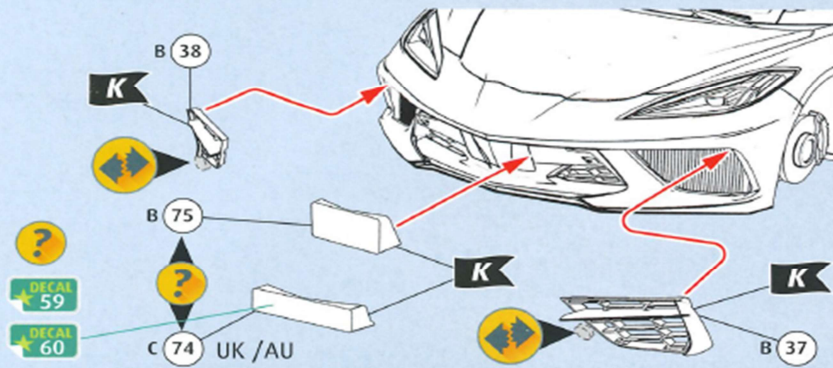

50

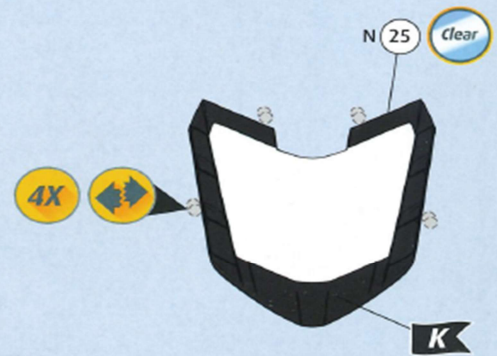

51

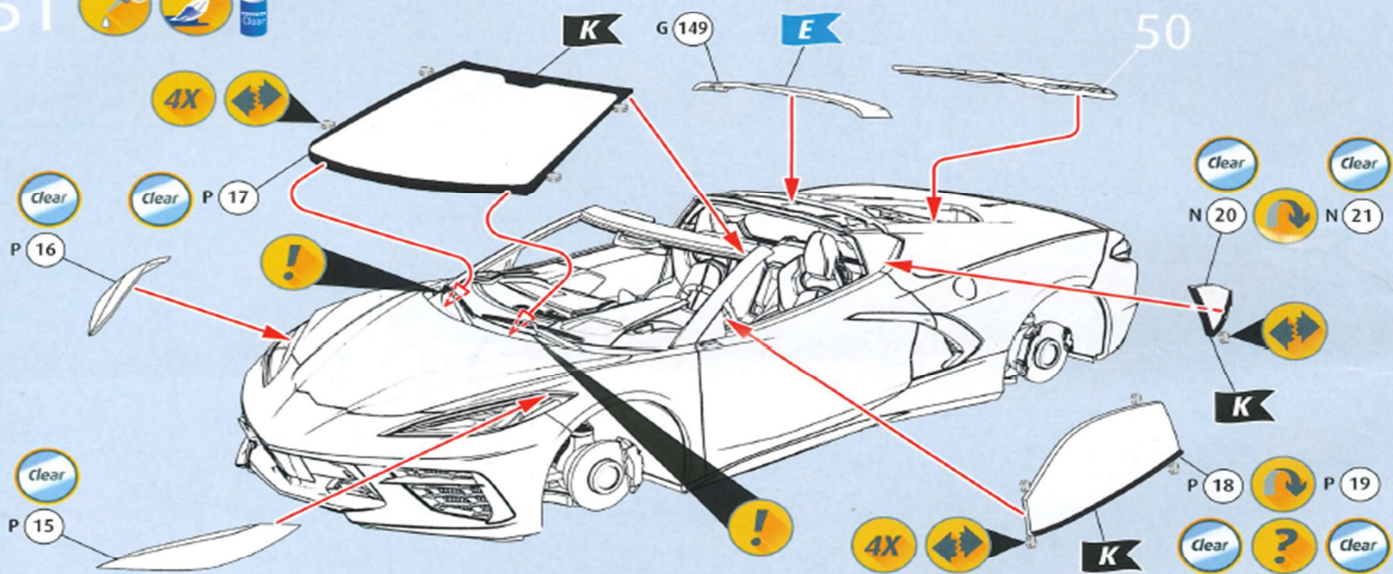

52

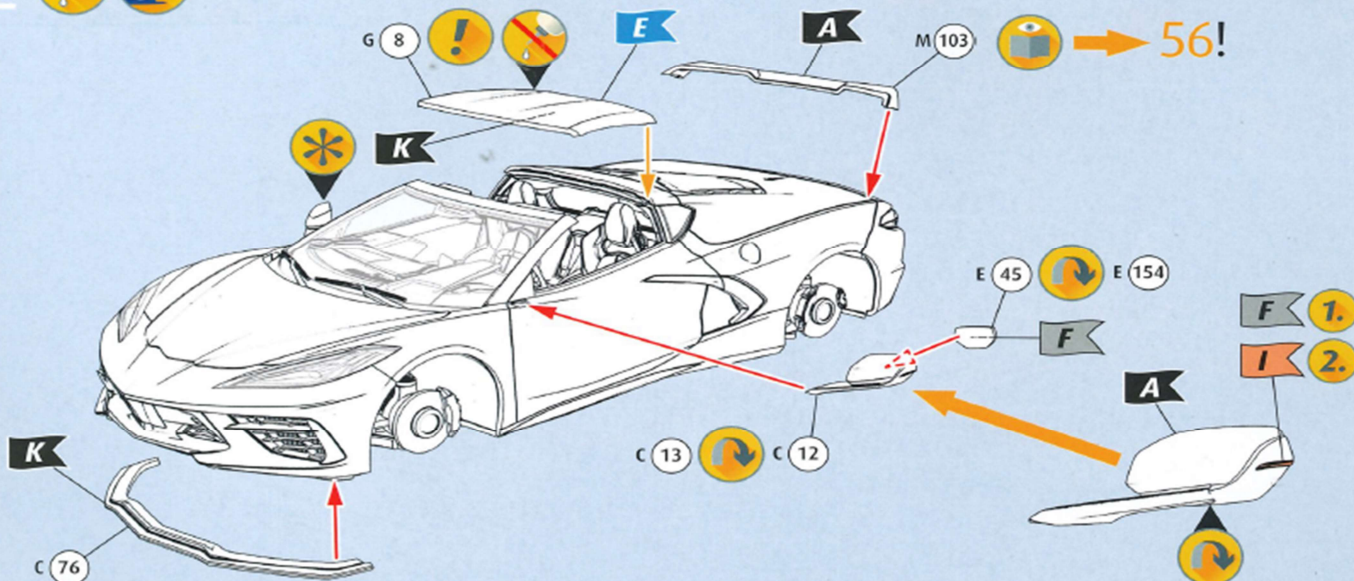



53 

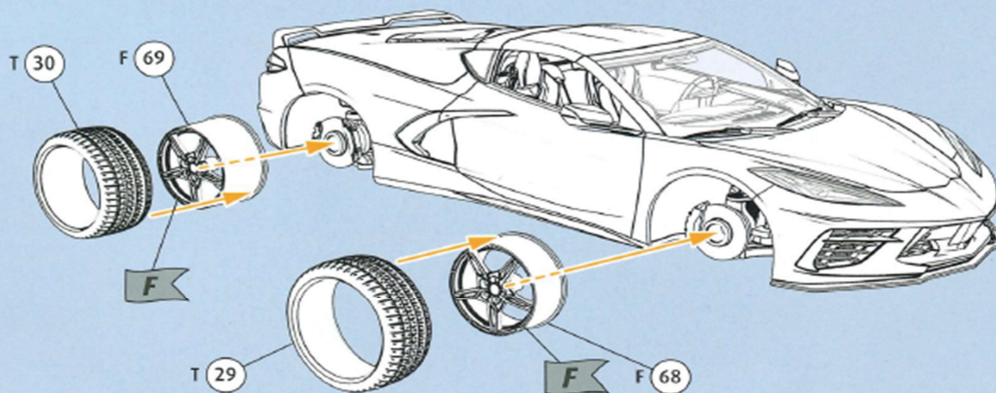

54 

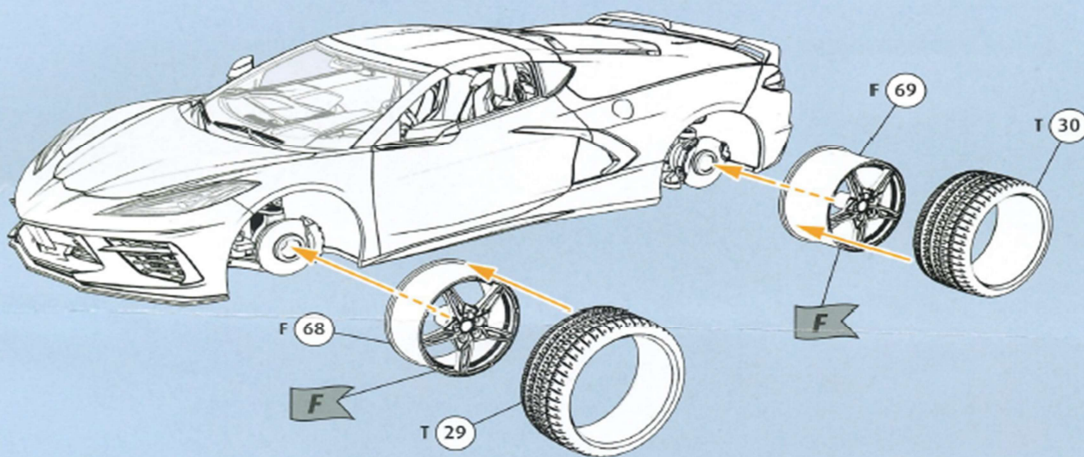

55    

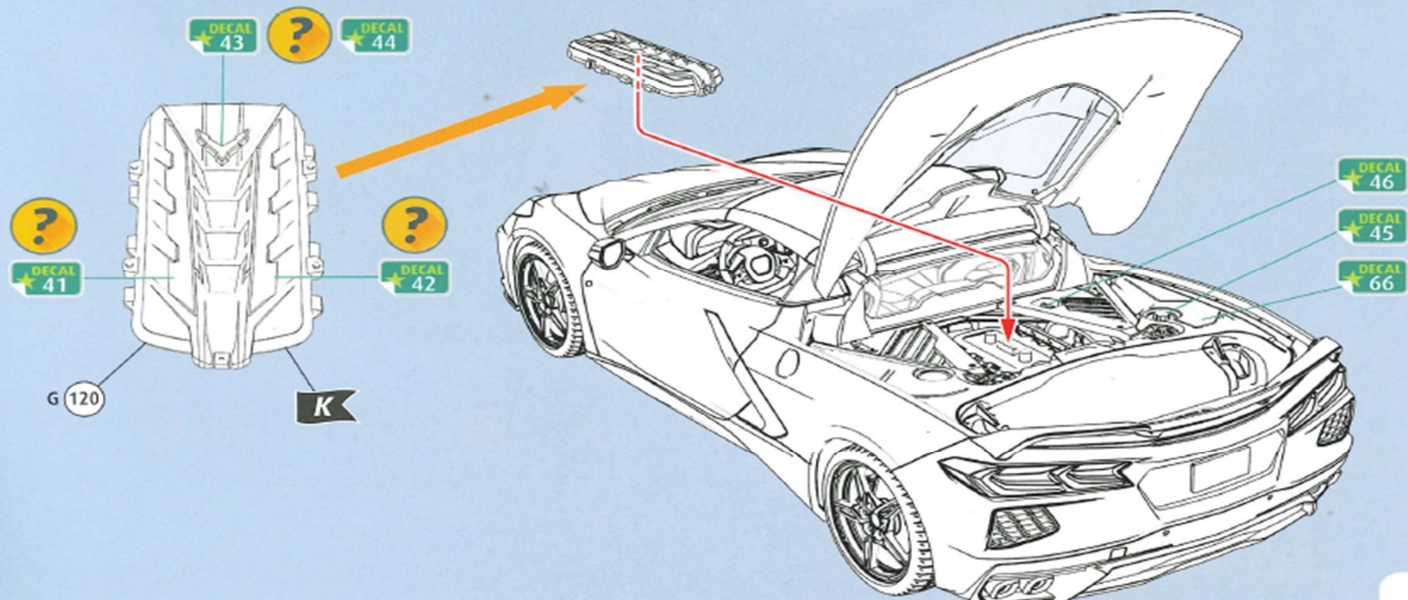





A D E F I J K

