

BEECHCRAFT T-34A MENTOR

1/72 SCALE

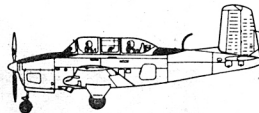

JS-088

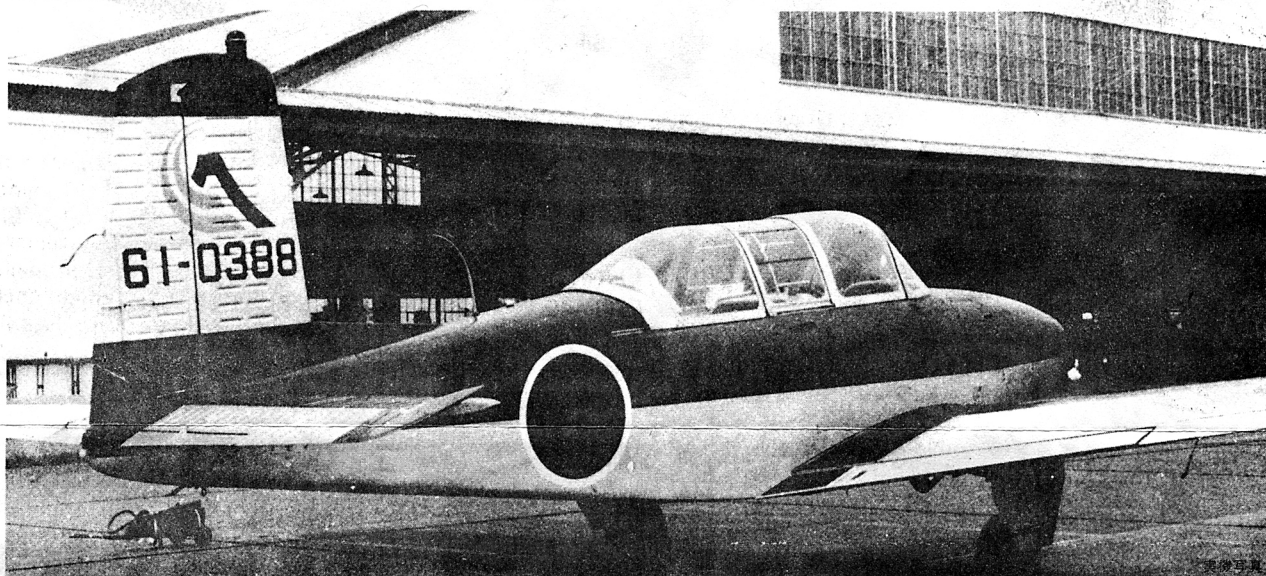

HISTORY

First flown on December 2, 1948, the two-place Mentor trainer is currently in use by ten nations as a basic pilot-training aircraft. Over 1,200 of these versatile planes were built, many of them under license in Japan, Canada and Argentina. In 1953 the Mentor was declared winner of a competition for a replacement of the T-6 trainer in use from World War Two. As a result, the U.S. Air Force purchased 450 T-34A Mentors while the U.S. Navy received 423 T-34B's.

A development of the popular Vee-tailed Beechcraft Bonanza, the T-34 uses several major components of this famous light plane. When it was first introduced to the U.S. Armed Forces it proved to be an outstanding aircraft for the initial training of America's airmen. For over fifteen years the Mentor was the standard primary trainer for budding American pilots. Each pilot flew the T-34 for 30 hours before graduating to the more powerful T-28 and then on to jets.

The Mentor is easy to fly and is still in use for flight instruction programs ranging from aerobatics to weapons delivery; it has been fitted with two 30 cal. machine guns and two 150 lb bombs or six rockets for this latter role.

SPECIFICATIONS

WINGSPAN: 32 feet 10 inches

LENGTH: 25 feet 10 inches

POWERPLANT: One 225 hp Continental O-470-13 six cylinder air cooled engine

MAXIMUM SPEED: 189 mph

SERVICE CEILING: 20,000 feet

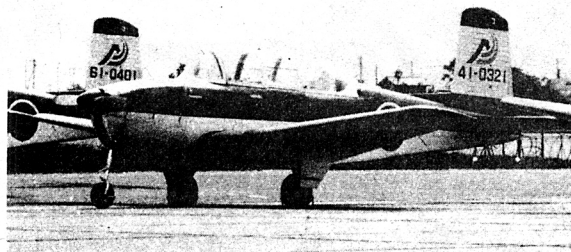

DISTRIBUTED BY MINICRAFT MODELS, INCORPORATED
1510 W. 228TH STREET, TORRANCE, CALIFORNIA 90501

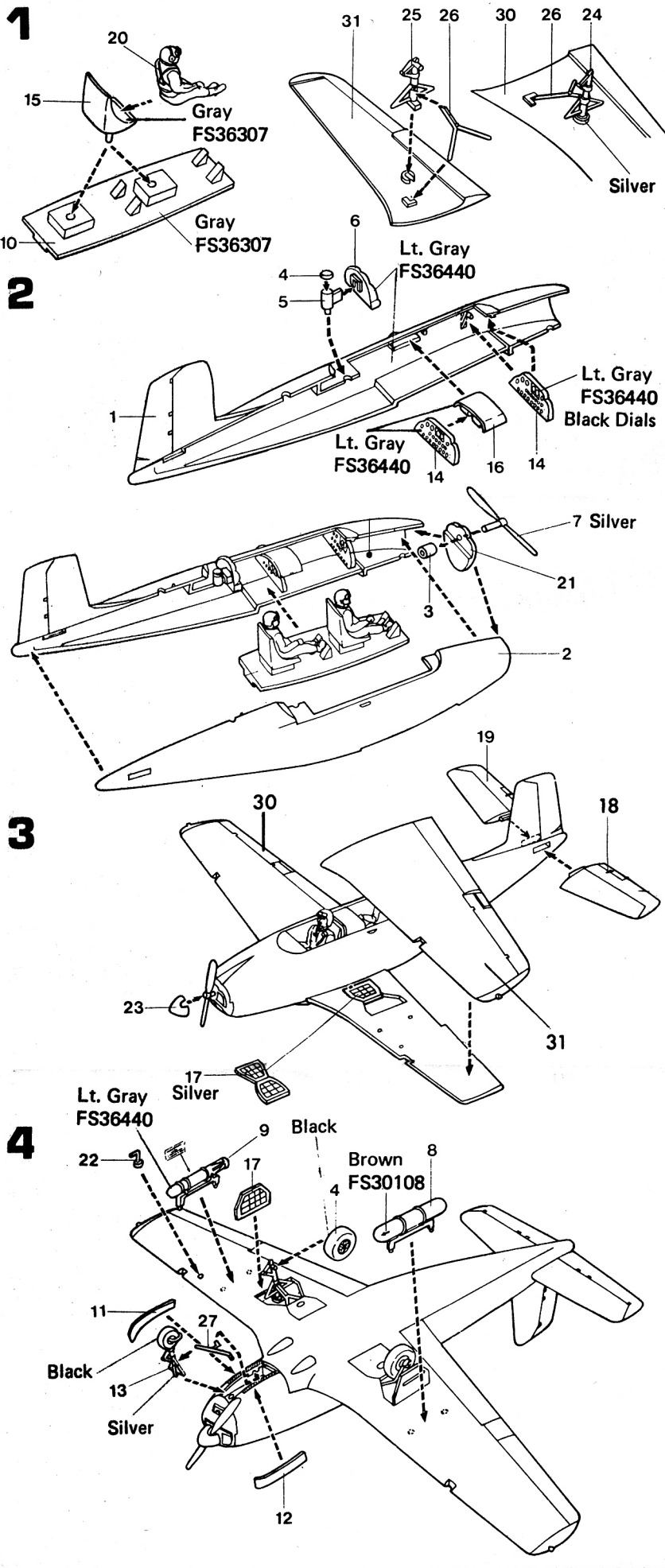

Cement pilot figures 20 to seats 15 and cement seats to 10. Cement 25 and 26 to 31. Cement 24 and 26 to 30.

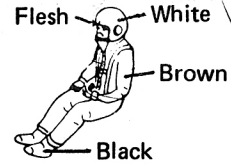

Cement clear part No. 4 to 5 then cement 5 to 6. Cement this assembly to 1 as shown. Cement one 14 to 16 then cement 16 and remaining 14 to 1. Slide shaft on 7 through hole in 21 then carefully cement 3 to shaft. Do not let cement touch 21 or propeller will not turn. Cement 21 to 1 as shown. Cement cockpit assembly in place in 1 then cement fuselage sides 1 and 2 together.

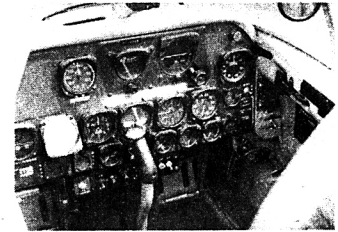

There are two parts 17. Each one should be separated along the scored line to form an inner and outer gear door. Cement both inner door segments in place on lower wing 29. Cement 29 to fuselage assembly then cement upper wing surfaces 30 and 31 to 29. (Carefully slide landing gear struts wheel well openings in this assembly.) Cement 18 and 19 to fuselage assembly. Cement 23 to propeller.

Cement outer gear doors in place on struts then cement one 4 to each axle. Cement 27 and 13 into nose wheel well as shown by arrows. Cement 11 and 12 to each side of well. Cement 8, 9 and 22 under the wings as shown.

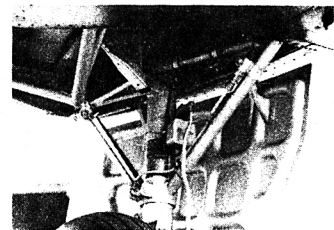

5

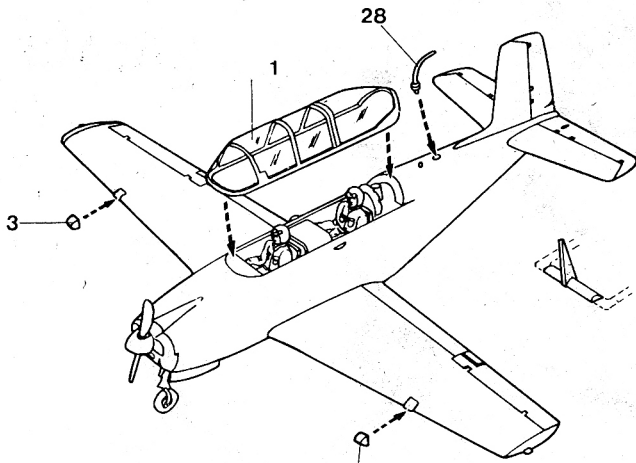

6

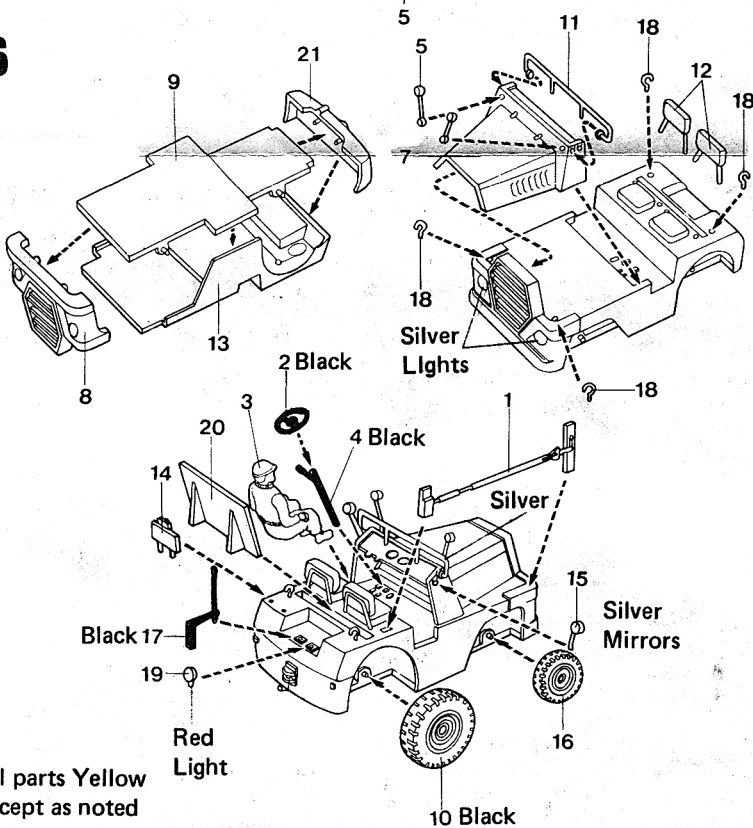

All parts Yellow
except as noted

Cement 28 to fuselage. Cement clear parts No. 1, 3 and 5 in place. Clear part No. 2 is a tail support which may be cemented to a section of clear runner as shown. Trim runner and place stand under tail to hold model in proper position.

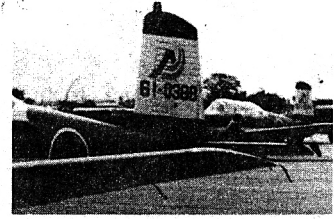

Cement 9 to 13 then cement 8 and 21 to body unit. Cement 7 to body, then cement 11 and two 5's to 7. Cement two 18's to the front fenders and two more to the rear fenders. Cement two 12's to back as shown. Cement 2 to 4 then cement 4 to floor. Cement driver 3 to seat. Cement 20 into slot behind seats. Cement 14, 15, 17 and 19 to body as shown. Cement 1 along right side of body. Cement wheels 10 and 16 to pins on body.

PART DRAWINGS AND PART NUMBERS
(Before Assembling Your Kit)

Read these instructions carefully before assembling your model and check the exact fit of the parts before cementing. Clean off excess plastic, if any, with a sharp knife or a file. Since many tiny parts are included, check them with the assembly drawing before assembling. Do not tear off parts from the stem, but cut them off carefully with a knife or clippers. Do not cut off all of the parts at the beginning, but cut each part to be assembled, one by one, to assure each part being properly identified. Do not use too much cement since surplus adhesive can spoil the finish.

T-34 PARTS

1. Left fuselage side
2. Right fuselage side
3. Prop retainer
4. Main wheels (2)
5. Compass
6. Rear bulkhead
7. Propeller
8. Tank
9. Bomb
10. Cockpit floor
11. Left nose gear door
12. Right nose gear door
13. Nose gear
14. Instrument panels (2)
15. Seats (2)
16. Instrument shroud
17. Main gear doors (2)
18. Left stabilizer
19. Right stabilizer
20. Crew figures (2)
21. Cowl front
22. Pitot tube
23. Spinner
24. Right main gear strut
25. Left main gear strut
26. Retracting struts (2)
27. Nose retracting strut
28. Antenna
29. Lower wing section
30. Right wing top
31. Left wing top

CLEAR PARTS

1. Canopy
2. Tail support
3. Right wing light
4. Compass cover
5. Left wing light

TRACTOR PARTS

1. Tow bar
2. Steering wheel
3. Driver
4. Steering column
5. Mirrors (2)
6. Rear tow bar
7. Hood
8. Grill
9. Body bottom
10. Rear wheels (2)
11. Windshield frame
12. Backrests (2)
13. Body
14. License
15. Lights (2)
16. Front wheels (2)
17. Hitch
18. Hooks (4)
19. Rear light
20. Plate
21. Rear panel

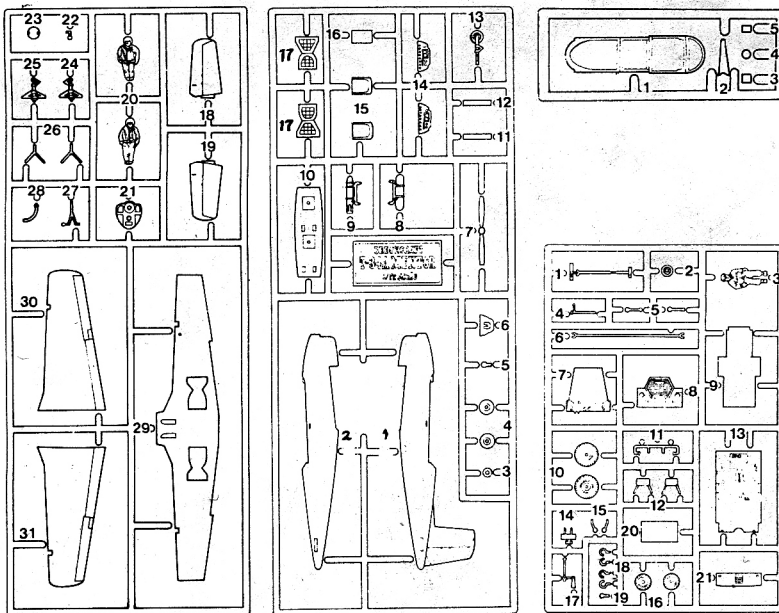

MARKING & COLOR PAINTING GUIDE

