

106

138, 139, 140, 141  
3pcs

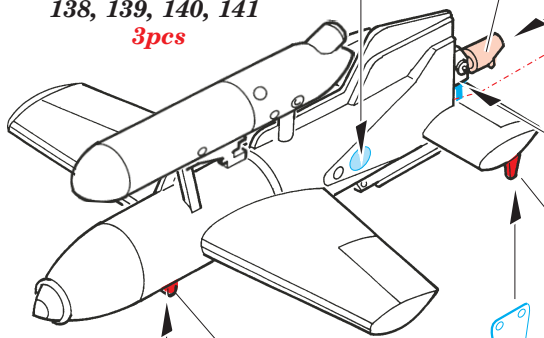

137

128

116

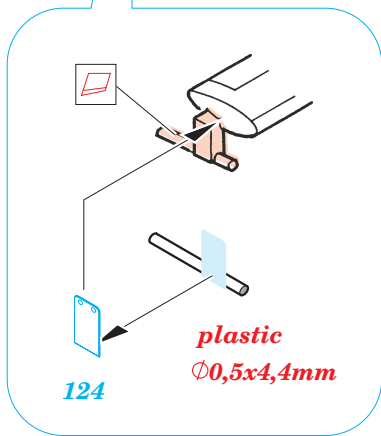
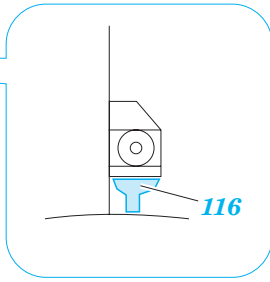

plastic  
Ø0,5x4,4mm

124

110

84

107

131

105

5pcs



### REFERENCES:

- Model Fan 2/2001
- Model Fan 3/2001
- Replika #29 (1/2003)
- Replika #30 (2/2003)
- Replika #35 (1/2004)
- Replika #49 (4/2006)
- Militaria #46..... He 177
- Replic 12/2000
- Warpaint #33.....Heinkel He 177



# He 177 Greif with HS 293 self adhesive

1/72 scale detail set for **REVELL** kit • sada detailů pro model **REVELL** 1/72

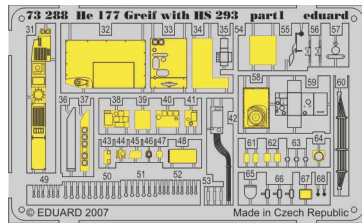
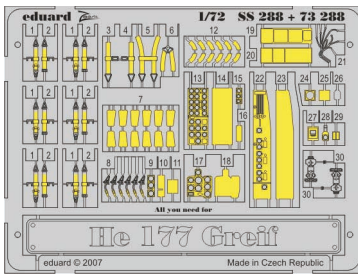

1. Separate the etched components from their frames on the protective paper. Removal from the paper is done only after separation of the parts from the frames.
1. Samolepicí díly oddělujte od rámečku na podkladovém papíře. Po oddělení je sejměte z krycího papíru.

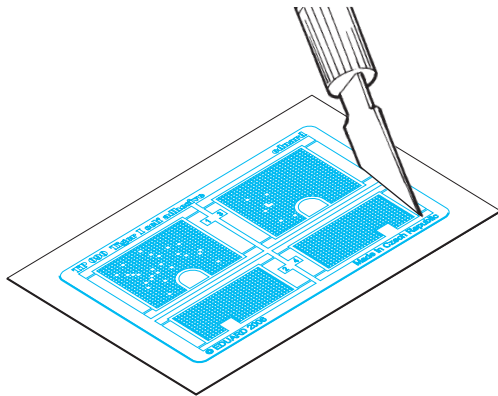

2. Do not inadvertently place etched components on an unwanted surface. Attempts to remove will result in damage to your part.
2. Nepokládejte samolepicí díly na volné plochy. Pokud je omylem přilepíte, při pokusu o odlepení dojde k poškození dílu.

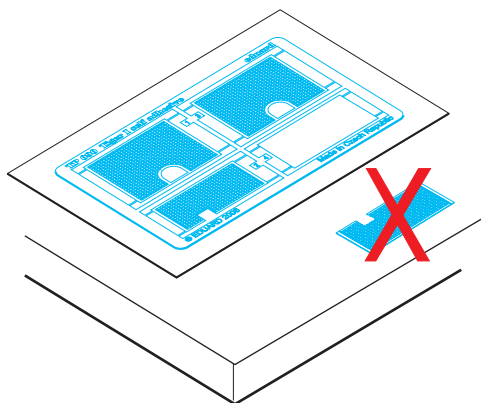

3. Do not touch the adhesive areas of the etched components.
3. Nesahejte na části dílů, na kterých je naneseno lepidlo.

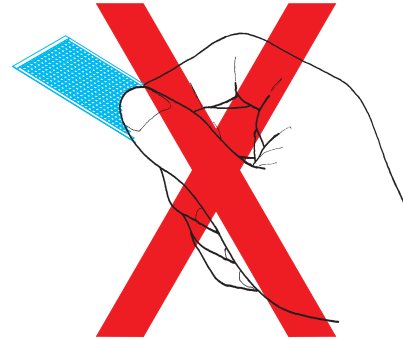

4. Hold the parts by the edges, or at areas free of adhesive.
4. Samolepicí díly berte za hrany nebo za části, na kterých není nanesené lepidlo.

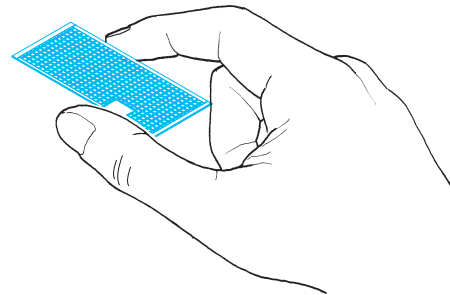

5. Lightly place the component in the desired location and position. Adjust as required. The component will be permanently affixed when pressed onto its intended location, its location can be adjusted.
5. Díl lehce položte do pozice, ve které má být nalepen. Upravte přesnou pozici a přimáčkněte. Díl dokonale přilne až po přimáčknutí, před přimáčknutím lze dílem opatrně manipulovat.

