

1/72 SCALE

F-51D MUSTANG The F-51D represents the typical Mustang configuration. It had a 37 foot wingspan, was 32 feet 3 inches long, and 13 feet 8 inches tall. The Packard built Merlin V-1650-7 engine was capable of delivering 1,695 hp which provided a speed of 437 mph at 25,000 feet.

After WWII, all aircraft with the "P" for pursuit designations were changed to "F" for fighter. The Mustang represented by this model, nicknamed "Was That Too Fast", is an F-51D from the 12th FBSq, 18th

1662
FBGp at Chinhae, Korea in the Fall of 1952. At the outbreak of the Korean War Mustangs were the backbone of the aerial forces lending much support to the newer jets.

The prototype Mustang, the NA-73 was assembled in only 120 days from when it was ordered. The P-51 was an instant success, outperforming even the British Spitfire. The first P-51's were named Apache but only for a short time until Mustang was permanently adopted.

Decal Placement and Painting Instructions

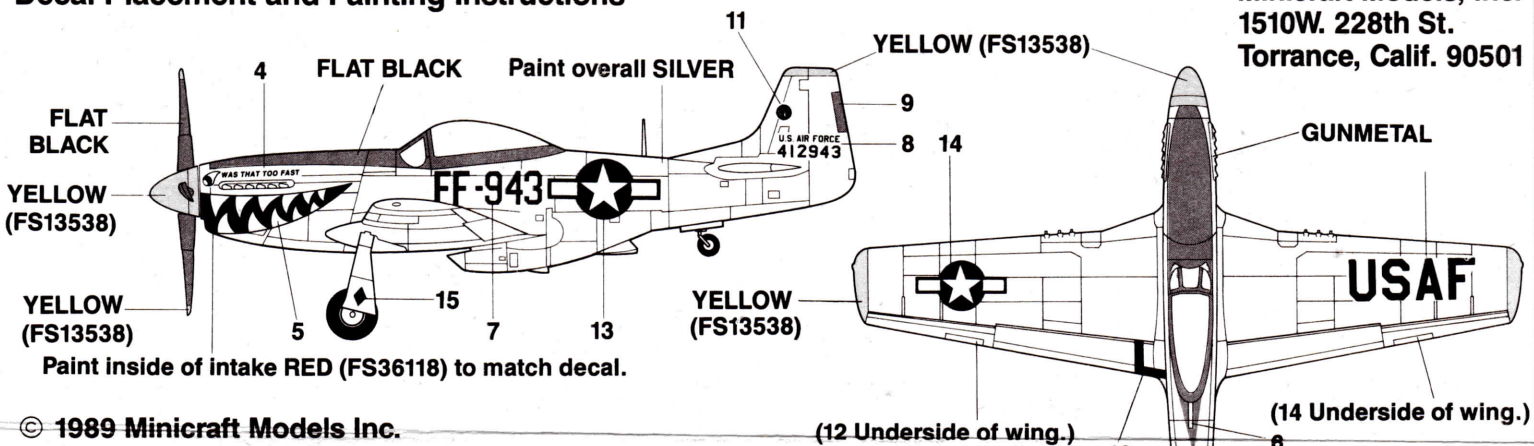

Minicraft Models, Inc.
1510W. 228th St.
Torrance, Calif. 90501

© 1989 Minicraft Models Inc.

ENGLISH	FRENCH	GERMAN	SPANISH	ITALIAN
YELLOW	JAUNE	GELB	AMARILLO	GIALLO
RED	ROUGE	ROT	ROJO	ROSSO
GUNMETAL	METALLIC	METALLIC	METALICO	METALLICO
GREEN	VERT	GRUN	VERDE	VERDE
SILVER	ARGENT	SILBERN	PLATA	ARGENTO
BLACK	NOIR	SCHWARTZ	NEGRO	NERO



Cement Parts
Colleer
Kleben
Pegar
Pegolare
Collare
Kleben



DU NOT cement
Ne pas colleer
Nicht kleben
No pegar
Non incollare
Nao colar
Niet kleven



Cut away
Couper
Scheiden
Cortar
Tagliare
Cortar
Snijden



Optional parts
Choix
Auswahlmöglichkeit
Eleccion
Scelta
Opcao
Keuze



3
Repeat operation
Répéter l'opération
Vorgang wiederholen
Repitir la operación
Repetire
Repitir a operação
Herhalen

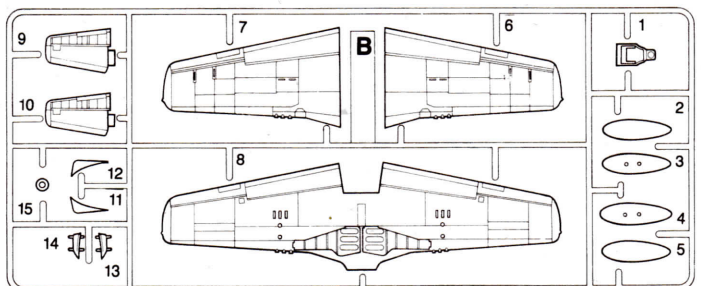
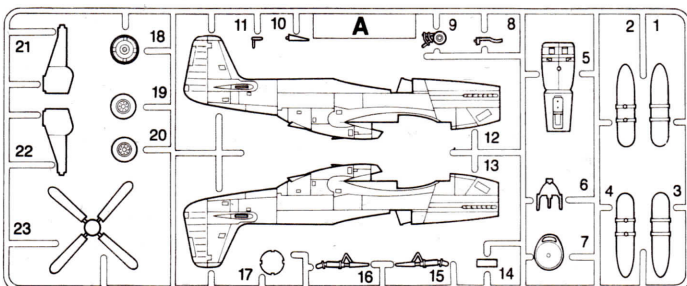

CLEAR

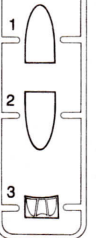

1 COCKPIT

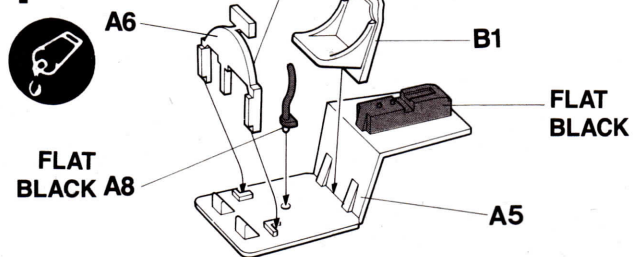

INTERIOR: CHROMATE GREEN

2 PROPELLER

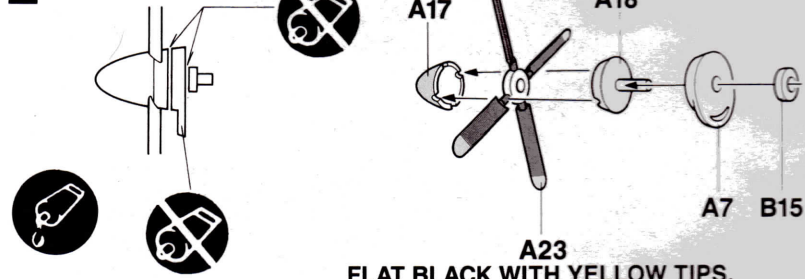

3 FUSELAGE

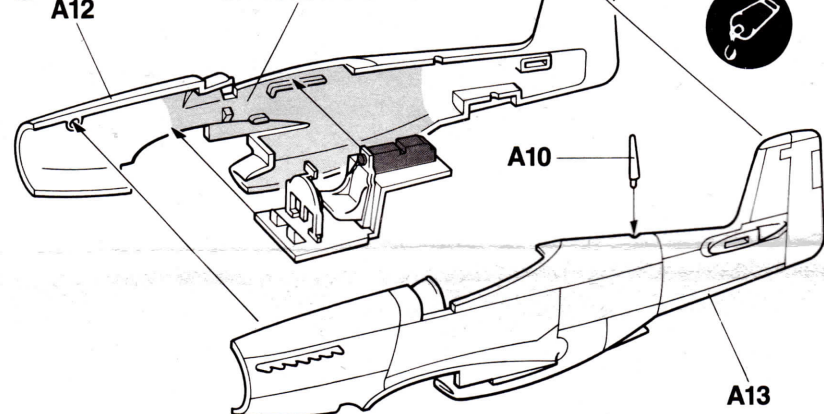

4 DROP TANK/NAPALM TANK

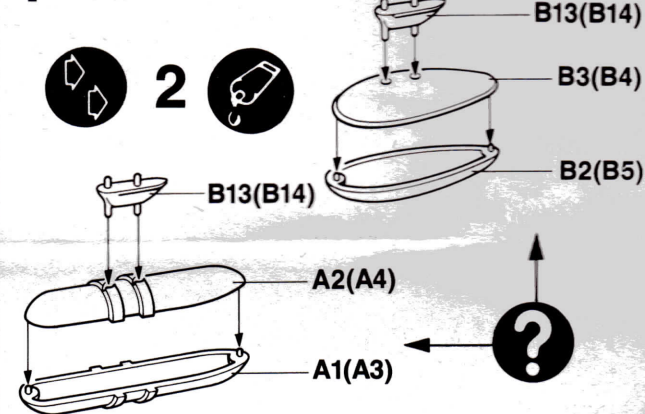

5 WING

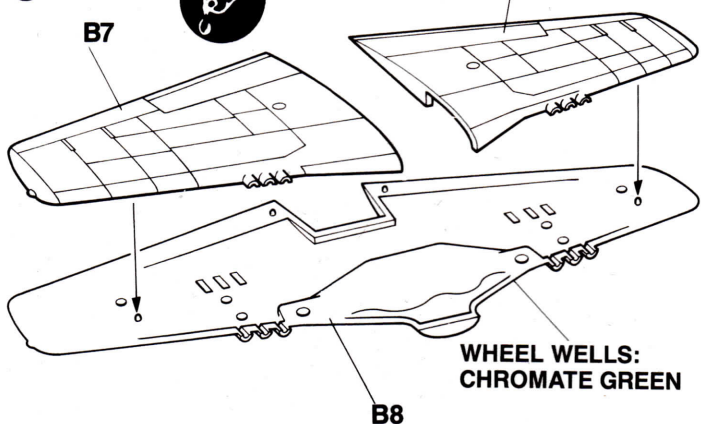

6 MAIN ASSEMBLY

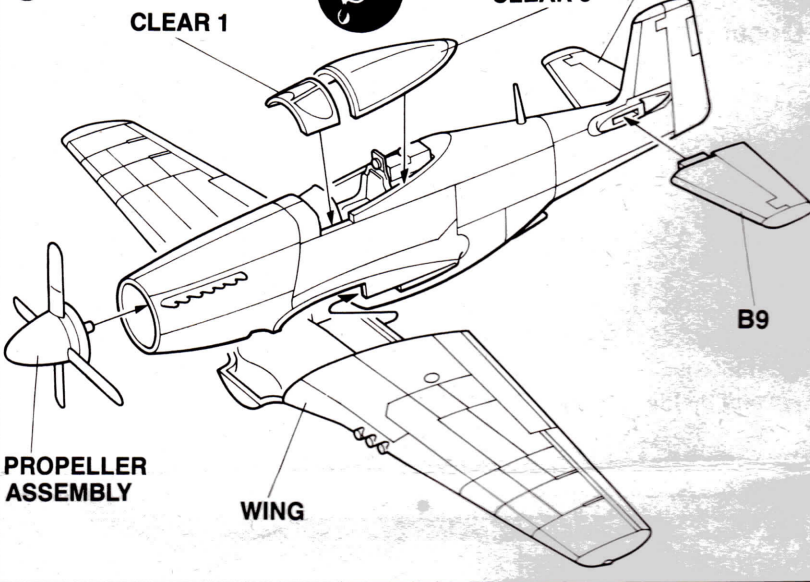

7 LANDING GEAR

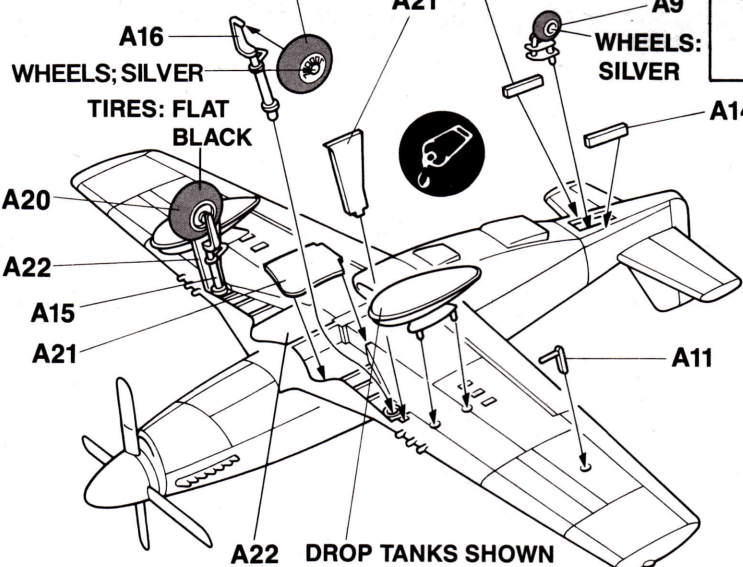

INSIDE WHEEL DOORS: CHROMATE GREEN

