

CONSOLIDATED

# PBY-5 CATALINA

Powered by two 1,200 horsepower Pratt & Whitney R-1830-92 engines, the **PBY-5** was the fastest of the entire **Catalina** family of flying boats! It could manage a top speed of 189 mph at 7,000 feet!

First delivered to the US Navy in 1940, production of the **Catalina** grew steadily due to many orders from the U.S. Navy, the RAF and other Allied air forces. When World War II erupted in December 1941, the **Catalina** was the principal Navy patrol and air-sea rescue aircraft in the US inventory. Flown by the RAF on anti-submarine patrols in the Channel, Mediterranean and Atlantic sectors, the **Catalina** already had an impressive service record by the end of 1941.

With a range of 2,990 miles the **Catalina** could remain aloft for many hours covering vast expanses of ocean. When a submarine was spotted, the **Catalina** could attack with four 1,000 bomb depth charges or could strafe with its four machine guns, two .30 caliber and two .50 caliber Brownings. Besides its attack role, the **Catalina** was best known and respected for its air-sea rescue missions during which countless aviators were plucked from enemy seas, sometimes right in the heat of battle. The crews who flew the **Catalina** on rescue missions were among the most appreciated aviators in the service. Many owe their lives to the daring courage of the **Catalina** crews and their tough but slow flying boats.

With a wingspan of 104 feet and a length of 63 feet-10 inches, the **PBY-5** was a big plane for its day, very close to the B-17 in wingspan but shorter in length. Designed without wing dihedral, all the **PBY** aircraft required constant attention from the pilot or copilot to ensure level and straight flight. Maybe this little fault was the biggest problem with the famous **Catalina** flying boats.

ENGLISH	FRENCH	GERMAN	SPANISH	ITALIAN
BLACK	NOIR	SCHWARZ	NEGRO	NERO
METALLIC	METALLIC	METALLIEK	METALICO	METALLICO
WHITE	BLANCO	WEISS	BLANC	BIANCO
GREEN	VERT	GRÜN	VERDE	VERDE
TAN	BRUN CLAIR	GELBBRAUN	CANELA	MARRONE CHIARO
SILVER	ARGENT	SILBERN	PLATA	ARGENTO

**ACADEMY**

HOBBY MODEL KITS

## 1 PILOT AND GUNNER'S POSITION ASSEMBLIES

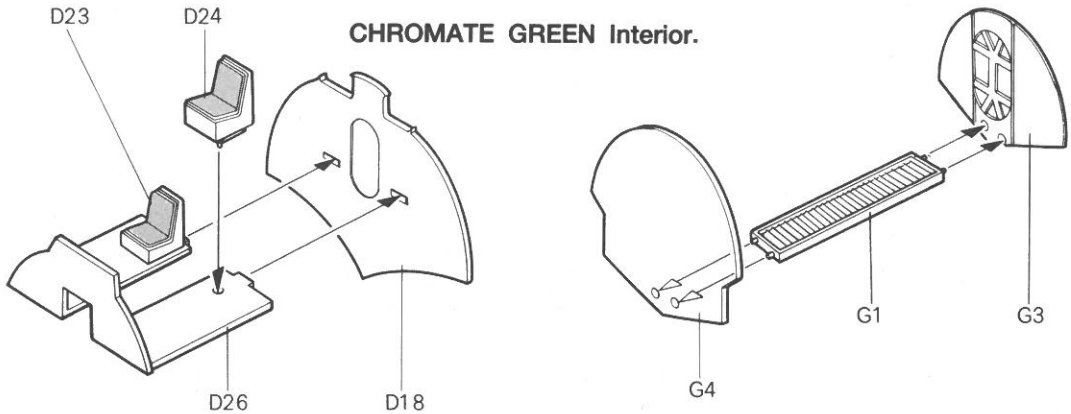

## 2 INTERIOR AND FUSELAGE ASSEMBLY



**CHROMATE GREEN Interior.**

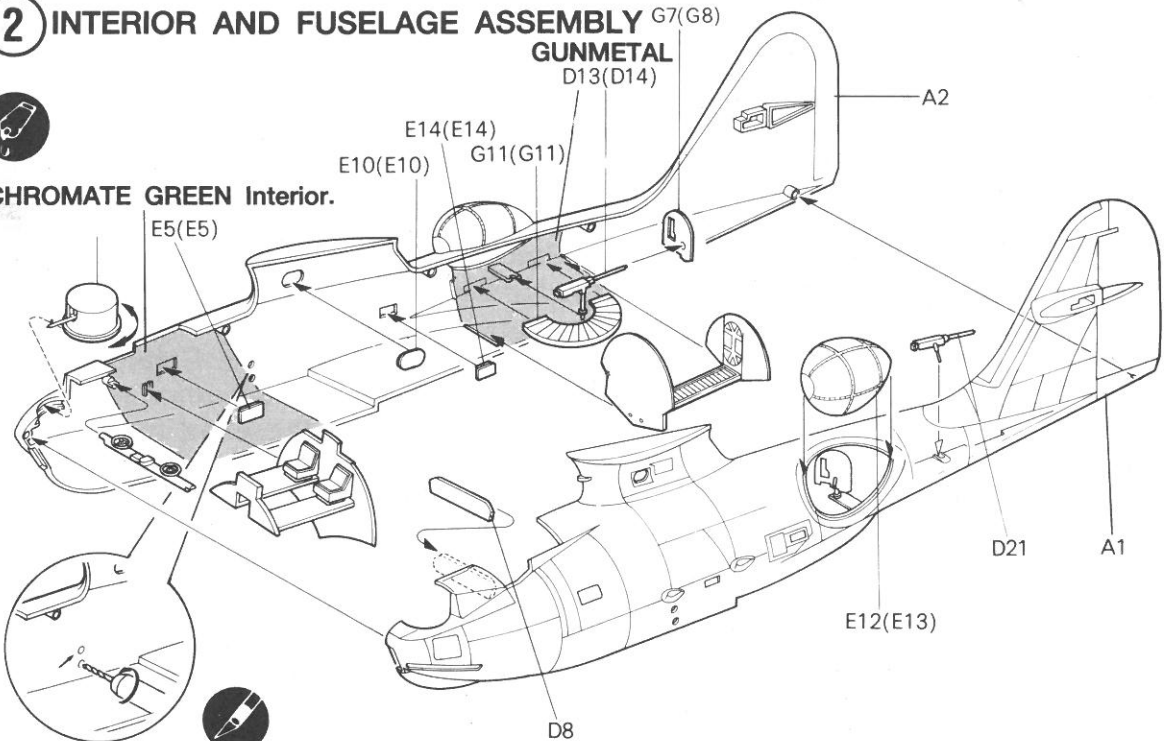

Open holes for Beaching Gear.

■ NOSE TURRET

■ INSTRUMENT PANEL

■ CONTROL HANDLES

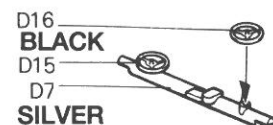
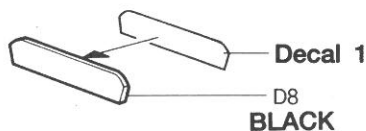

### 3 OUTER WING AND FLOAT ASSEMBLY



**2**

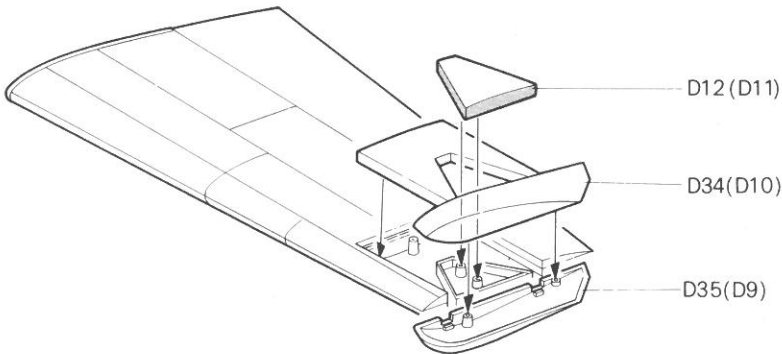
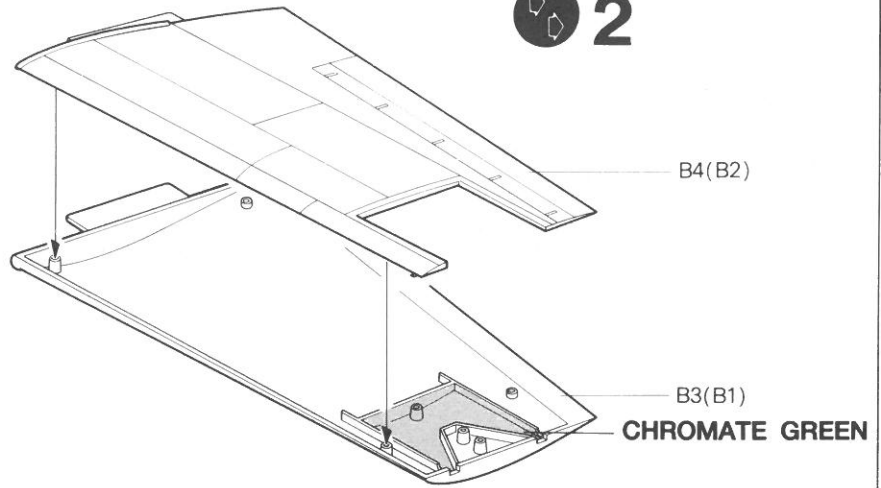

Choose up or down position for floats.

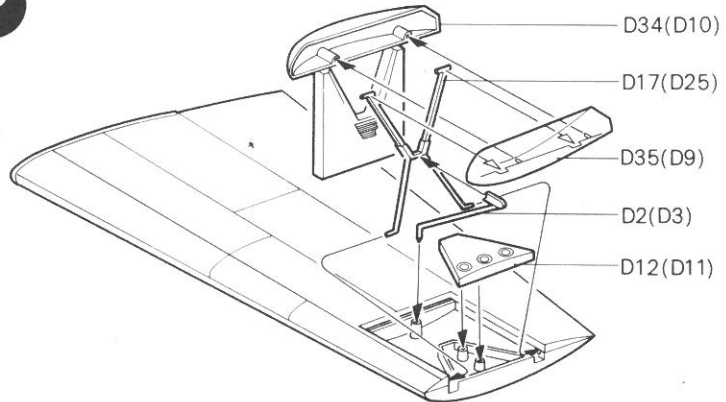

### 4 PROPELLER AND ENGINE/COWLING ASSEMBLY

■ A5

FLAT BLACK

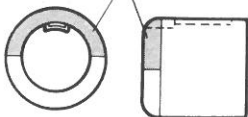

FLAT BLACK

G10  
(G10)

D1(D27)  
**SILVER**

A5(A5)  
**GRAY**

D29(D30)  
D19(D20)  
**METALLIC GRAY**

**2**

# 5 WING ASSEMBLY(CENTER SECTION)

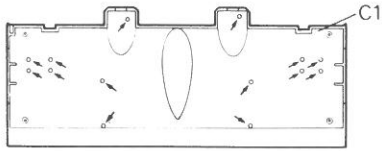

Open holes in C1 before assembly.

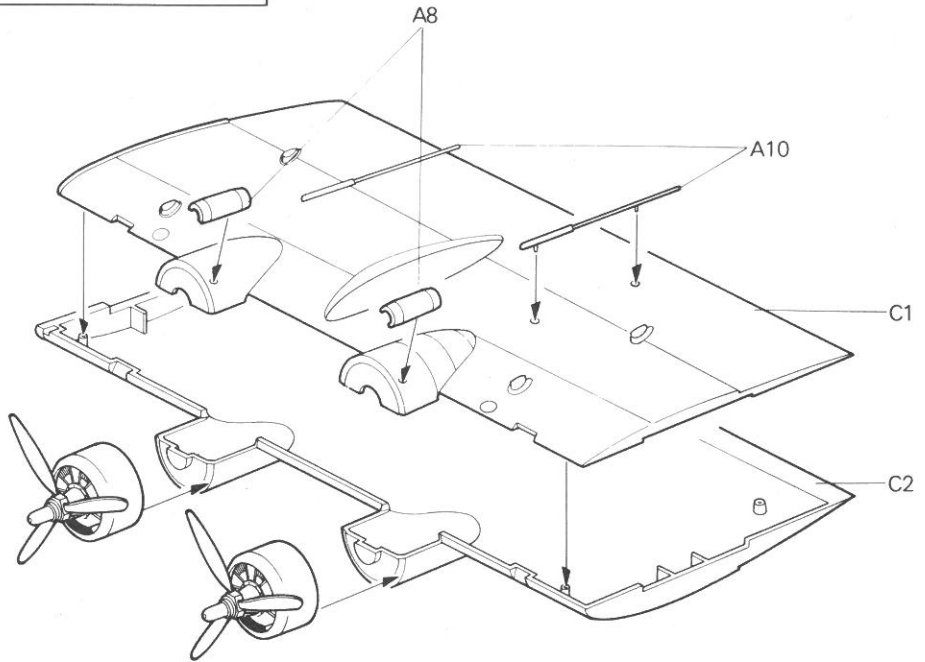

# 6 WING AND STABILIZER MOUNTING



A18  
**FLAT BLACK**  
 A11(A12) Left(Right)



**4**

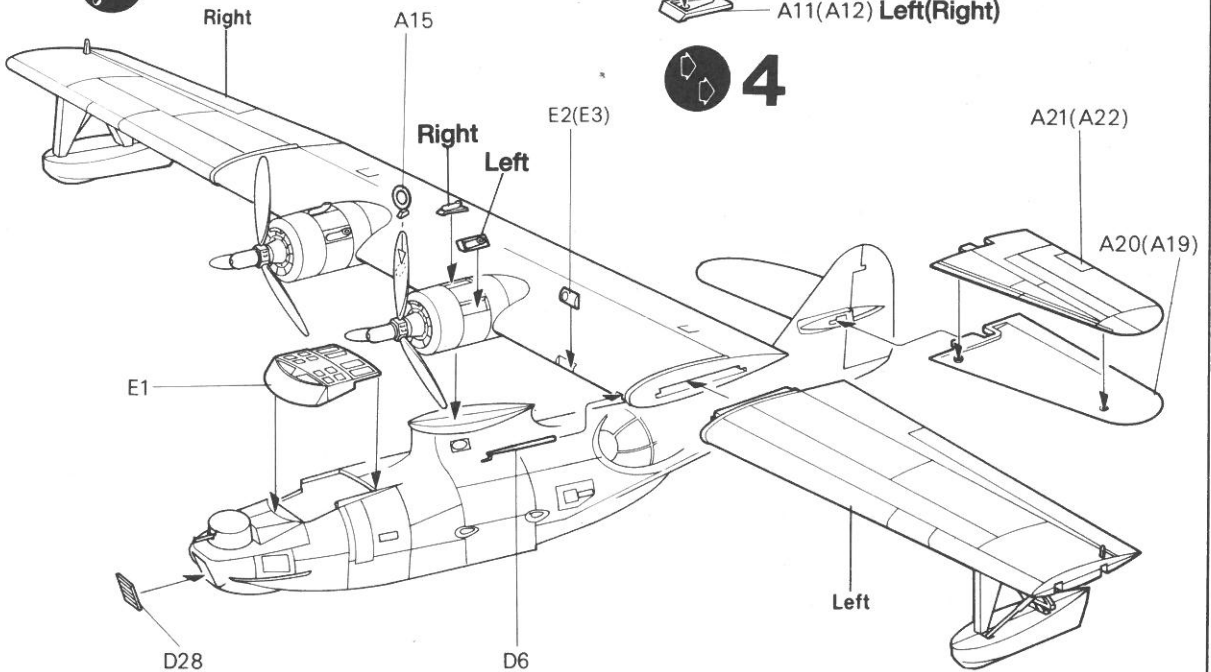

# 7 BEACHING GEAR AND DEPTH CHARGE MOUNTING



Struts and Wheels are SILVER.

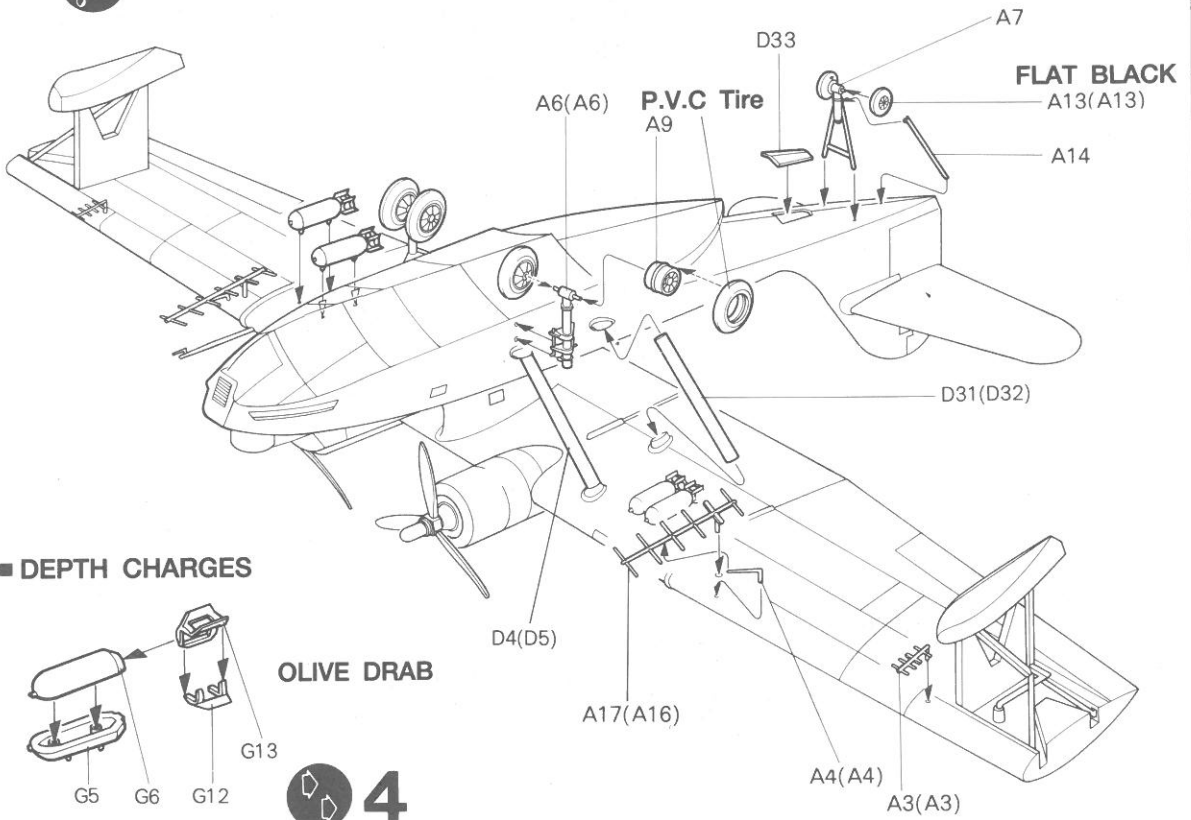

## ■ DEPTH CHARGES

OLIVE DRAB

## Painting and Decal Placement

- CHROME YELLOW FS 13538
- FLAT GULL GRAY FS 36440
- SILVER
- BLACK

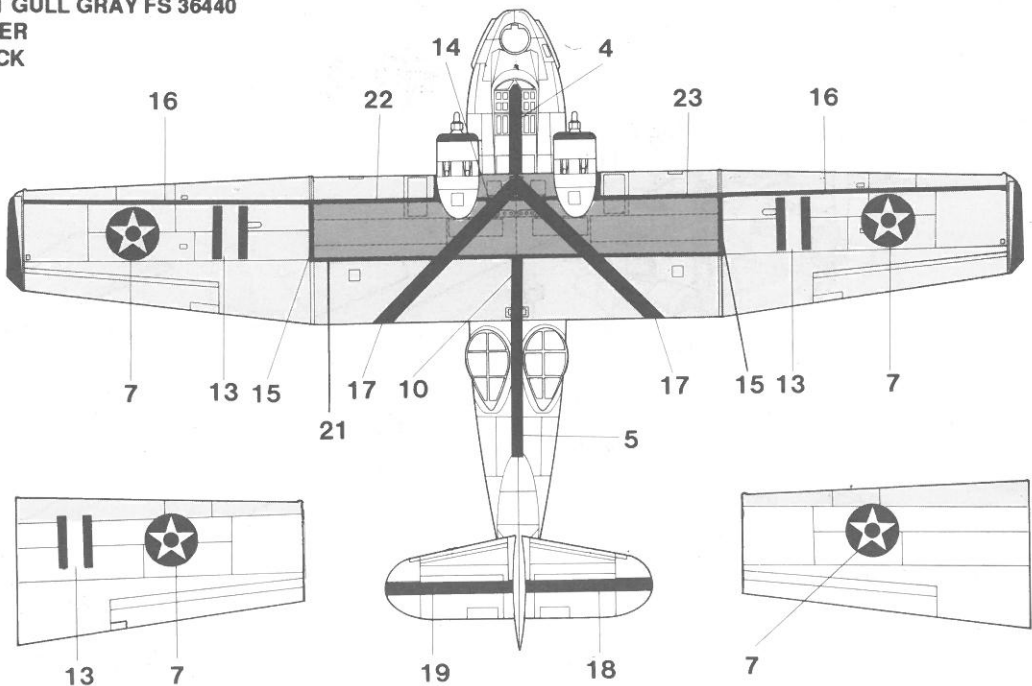

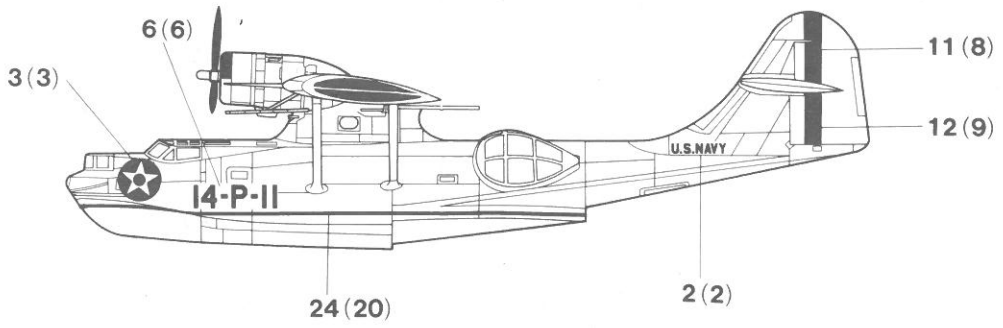

## Parts Locating Diagram

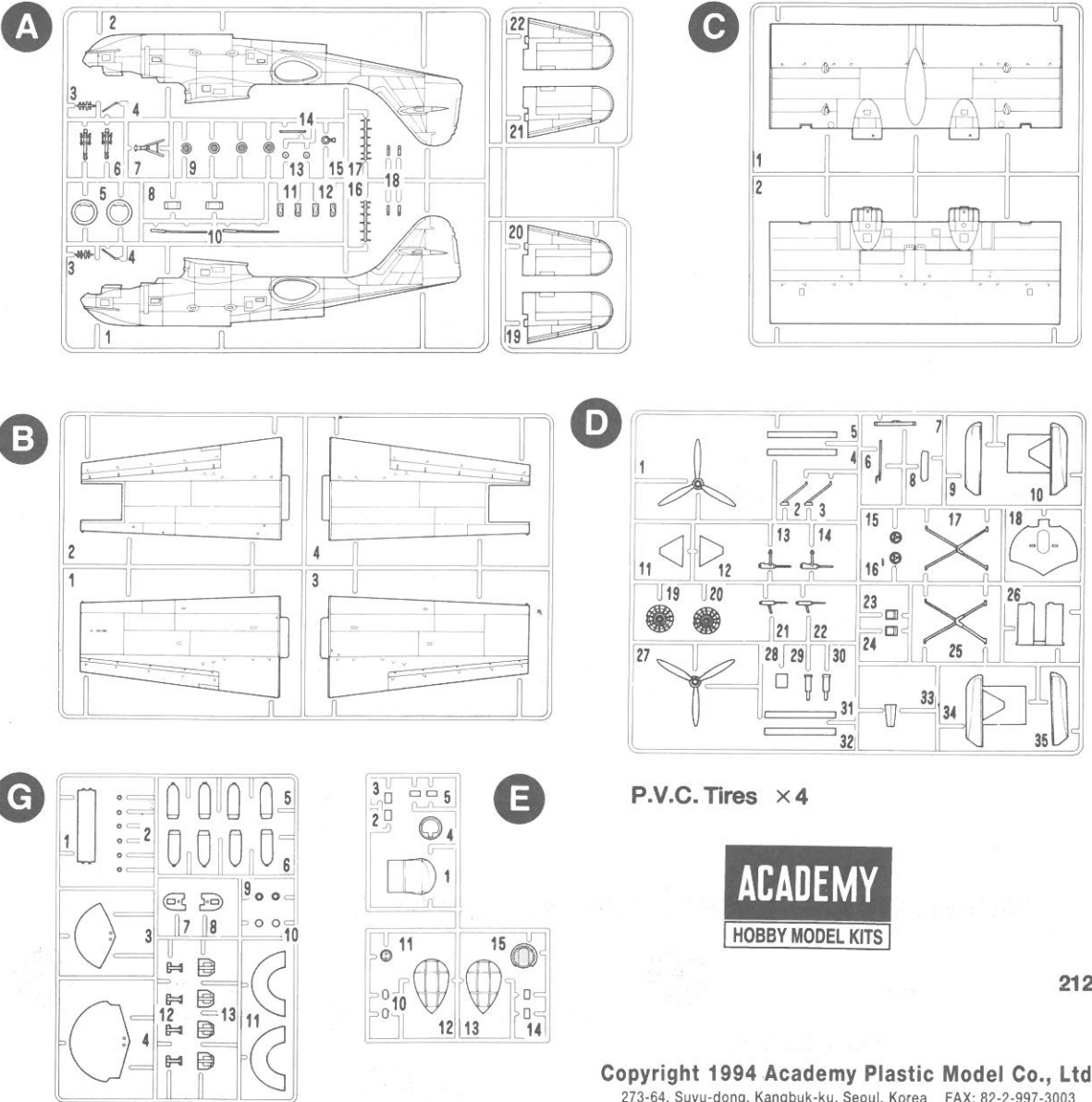

P.V.C. Tires × 4

**ACADEMY**  
HOBBY MODEL KITS

2123

Copyright 1994 Academy Plastic Model Co., Ltd.

273-64, Suyu-dong, Kangbuk-ku, Seoul, Korea FAX: 82-2-997-3003



Cement Parts  
Collar  
Kleben  
Pegar  
Incollare  
Colar  
Kleven



Do Not Cement Parts  
No Pas Collar  
Nicht Kleben  
No Pegar  
Non Incollare  
Nao Colar  
Niet Kleven



Cut Away  
Couper  
Scheiden  
Cortar  
Tagliaro  
Cortar  
Snijden



Optional Parts  
Choix  
Auswahlmoglichkeit  
Eleccion  
Scelta  
Opcao  
Keuze



Repeat Operation  
Répéter l'opération  
Vorgang Wiederholen  
Repitir la operación  
Repitir  
Repitir a Operação  
Herhalen

2 U.S.NAVY U.S.NAVY

5



1

14-P-II 14-P-II

6

4

22

8

11

18

19

13

14

15



17

9

12

23

21

13

20

16

24



3



7

