

Acknowledgements:

We would like to express our gratitude to Ömer Erkmen for the precious assistance provided during the preparation of this decal sheet.

Recommended references:

"Fictorial Turkish Phantoms –The F-4E and RF-4E of the Turk Hava Kuvvetleri" by Tuncay Deniz and Andreas Klein, AirDOC Publishing, 2008

"F-4 Phantom II", Modelers Datafile N°12 & 14, by Andy Evans, SAM Publications 2007/2008

Recommended model kits:

1/72 & 1/48: Hasegawa; Revell

Please use the HDL sheets 72-054 & 48-024 containing the respective F-4 walkways.

		Humbrol	Model Master
A	Gunship Grey FS 26118	125	1723
B	Medium Grey FS 26270	126	1725
C	Radome Grey FS 26320	128	1741
D	Radome Black FS 27038	85	1597
E	White FS 27875	130	1596
F	Aluminium	27002	1401
G	Steel	27003	1405
H	Exhaust	27004	1406

F-4E / F-4ETM / RF-4ETM PHANTOM II

HDL 72058 / 48028

©ROGOZ / HI-DECAL 2013

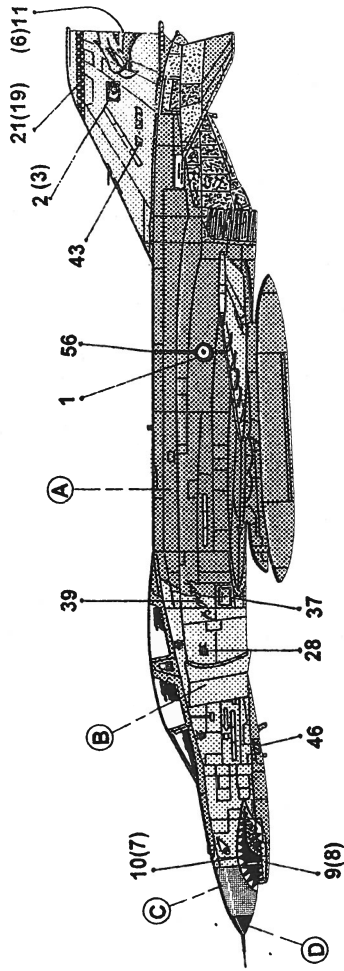

3 F-4E 67-0227, 172nd Sqn. "Sahin", TuAF. 7th Main Jet Base Erhac / Malatya, 2010

This Phantom was delivered to the TuAF under Peace Diamond III during 1987 and served with the 172nd Sqn in the Air Defense role, till the unit's disbandment in May 2009.

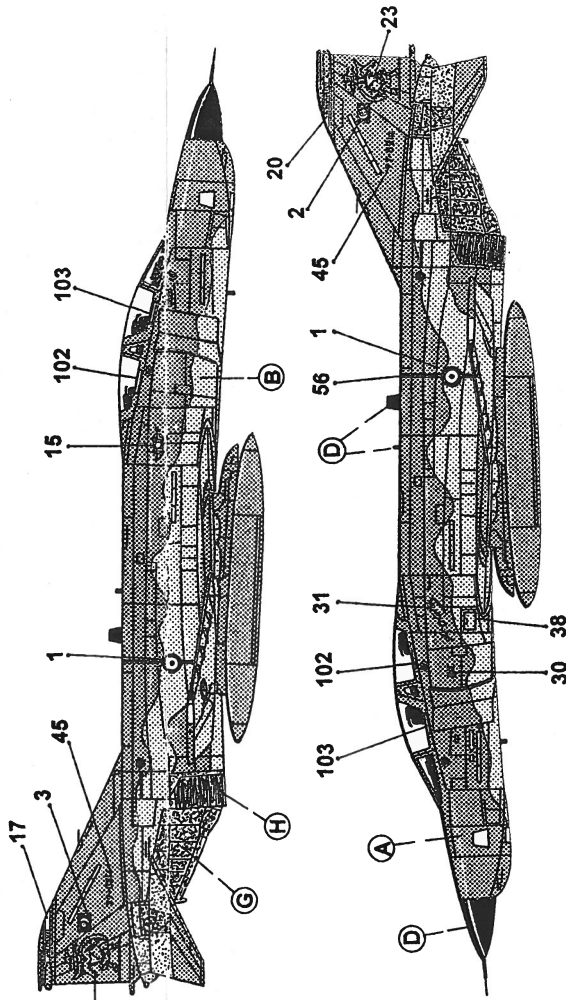

4 RF-4ETM 77-0314, 173th Sqn "Safaklar", TuAF. 7th Main Jet Base Erhac / Malatya, 2012

This LES equipped recon jet was one of the eight new-built RF-4Es delivered to the TuAF during 1979 under Peace Diamond II. 77-0314 was one of 18 aircraft modernized to the newest RF-4ETM standard during 2010 and one of only two TuAF Phantoms to employ the IA/ELOP LOROP recon pod, housing the KS-146B long-range oblique camera. 77-0314 was lost above the East Mediterranean Sea, shot down by a Syrian SAM, on June 22nd, 2012.

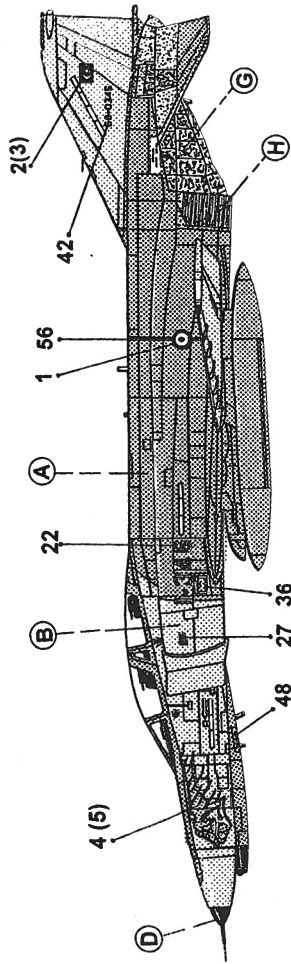

1 F-4E 67-0346, 111th Sqn "Panter", TuAF. 1st Main Jet Base Eskisehir, 1992

This F-4E previously served with the 141th TFS, NJ ANG, and has been transferred to the TuAF under the Peace Diamond VI program in August 1991. The 111th Sqn uses their Phantoms in the Fighter-Bomber role.

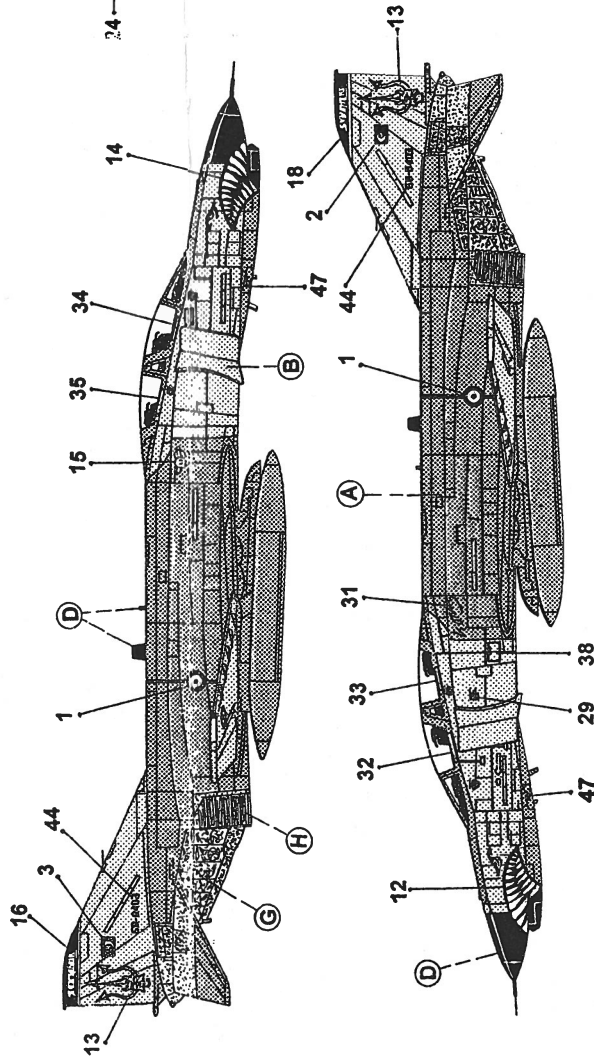

2 F-4ETM 68-0403, 112th Sqn. "Seytanlar", TuAF. 1st Main Jet Base Eskisehir, 2011

This jet came to the TuAF from the 110th TFS, 131st TFW, Missouri ANG, during 1991 under Peace Diamond VI. It was the first of 16 F-4Es to be upgraded to the F-4ETM "Simsek" (Lightning) standard during 2010. The 112th Sqn uses the F-4ETM in the Air Defence role.

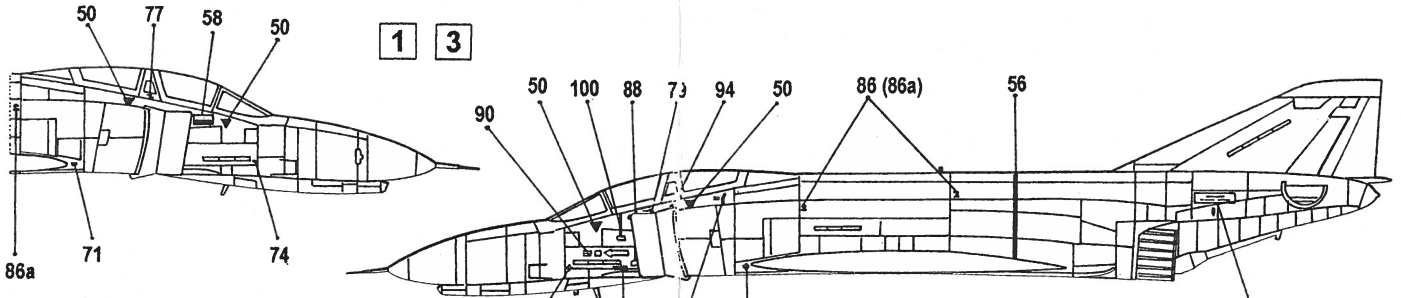

Stencilling color notes:

Versions [1] and [3] have maintenance stencil data applied in yellow

Versions [2] and [4] have maintenance stencil data applied in contrasting grays

Versions [1] and [3] Have the arrestor hook markings (52 & 53) applied in white & red

Versions [2] and [4] Have the arrestor hook markings (54) applied in red only

All versions have ITMEYINIZ (59 & 60) and BASMAYINIZ (61 & 62) applied in contrasting grey colors.

All versions have the ejector seat / flares warning triangles (50 & 55) applied in red

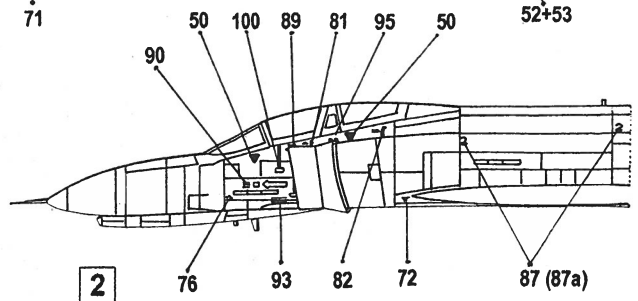

2

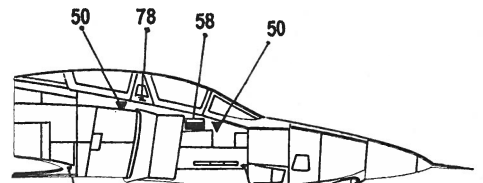

4

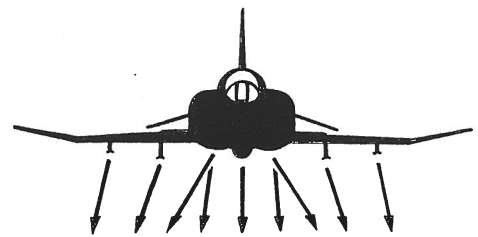
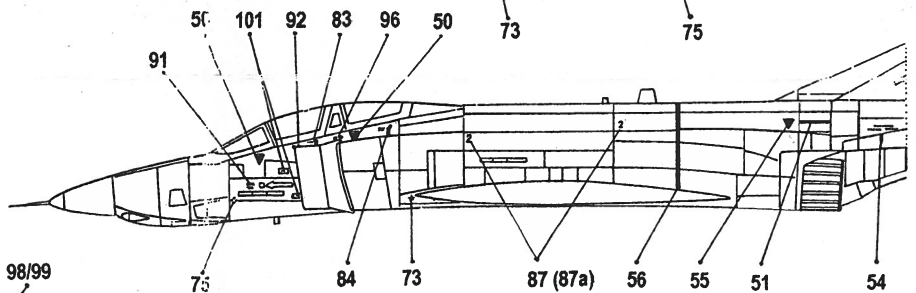
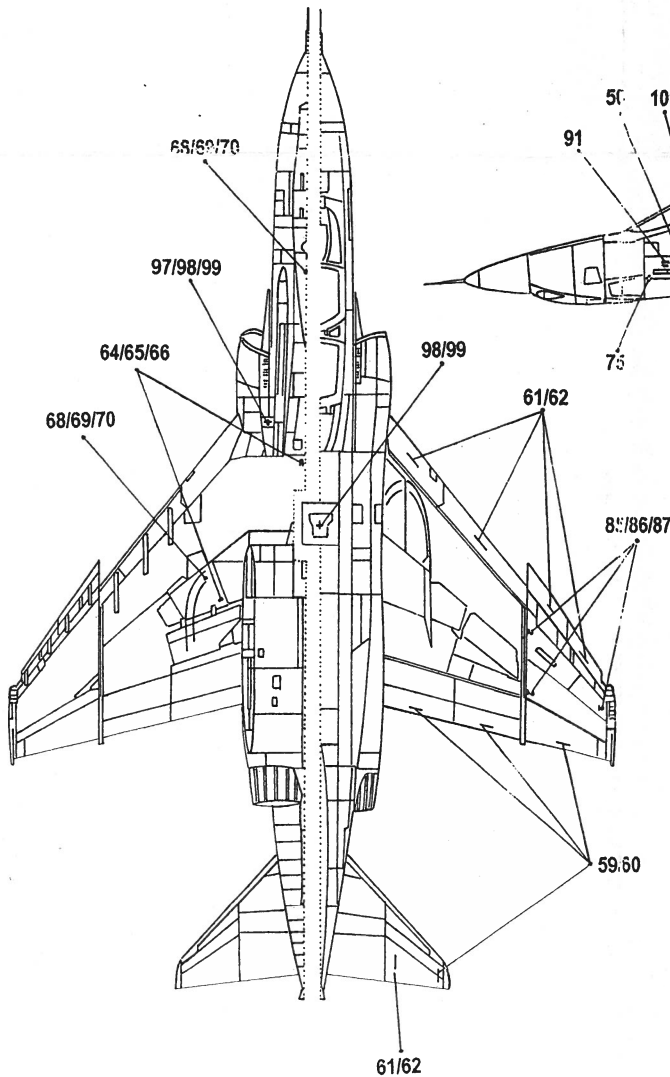

1	a	e		a		e	a
2	a	d		a		d	a
3	a	d	c	a	c	d	a
4	a	d		f		d	a

- a: 370 Gal. Fuel Tank
- b: 600 Gal. Fuel Tank
- c: AIM-7M Sparrow
- d: AIM-9P or L Sidewinder
- e: 3 x AGM-65A Maverick
- f: IAI/ELOP LOROP recce pod

F-4E / F-4ETM / RF-4ETM PHANTOM II

HDL 72053 / 48028

c ROGOZ / HI-DECAL 2013