

modelcraft

Kit # 48-010

PRECISION 1/48 SCALE

HARVARD Mark 4

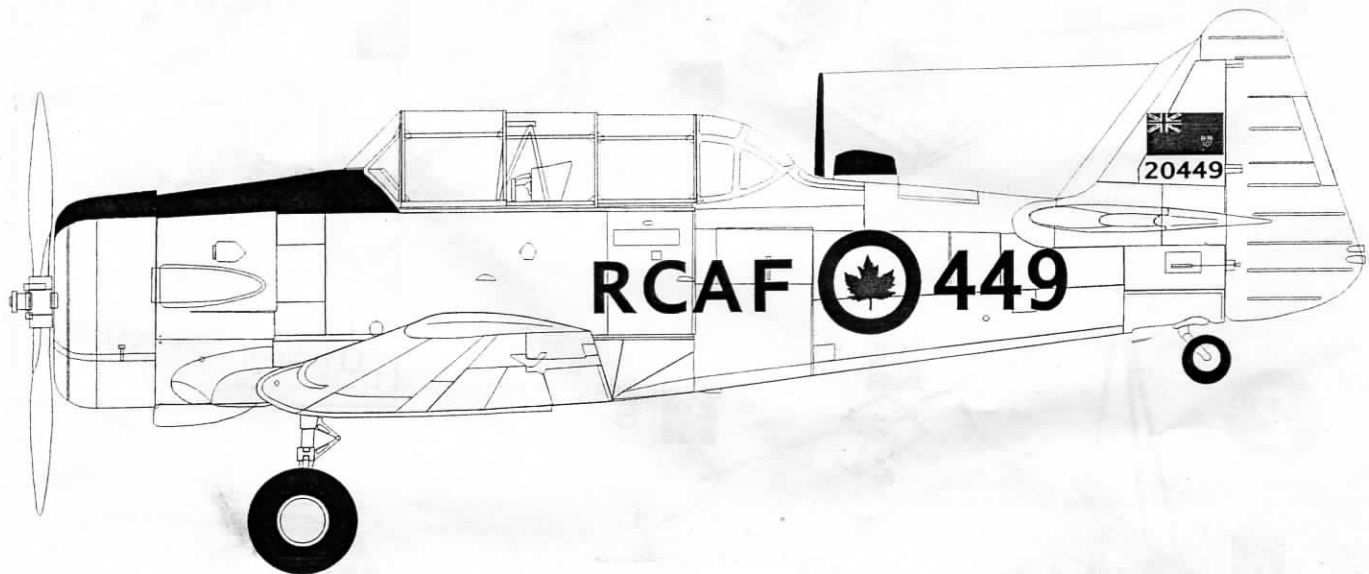

Even before WWII, the Royal Air Force had established an ambitious expansion program both on personnel and aircraft. Unable to get the resources it was seeking at home, the RAF looked to the USA aviation industry for solutions.

With North American Aviation (NA) the RAF found the training aircraft it was looking for. Based on the NA proposal for the NA BT-14 "Yale", which was already in service with French and Army Air Corps air forces, RAF chose it's own version of the BC-1, (NA-49). So was born the first of a long and distinguished line of "Harvard's" and the beginning of a legend. The "Harvard" MkI was a BC-1 with a 600HP engine and British style standard radio and flight instruments gear.

The first 200 aircraft and some that followed were delivered directly by sea to the RAF on British Islands.

With the beginning of World War II and the relocation of training programs throughout Canada, South Africa and even USA training air bases, the next "Harvard" orders flew directly from NA factory plants to their respective training bases.

For Commonwealth pilots, Canada was the primary destination for training and that is one of the reasons why the name "Harvard" is so intimately connected with Canada.

Even during the war and following the natural evolution of it's "brother's", the AT-6 and SNJ, the "Harvards" grew into new versions — MkII/III and MkIIA/IIB. These versions were produced by the thousands not only by NA in its US plant but also by Noorduyn Aviation Company in Canada.

In 1951, and after a similar refurbished program initiated by NA, Canadian Car Foundry, the successor of Noorduyn, produced which is understood by many to be the definitive "Harvard". Five hundred and fifty-five new "Harvards" were produced and designated MkIV/T-6J.

Flying in New Zealand, Rhodesia, Israel, USSR, Germany and many more countries, "Harvards" knew many different colours and schemes. This kit represents a Harvard Mk.4 of the "Goldilocks" air acrobatic team in the early 1960s.

With this new release, Ocidental Replicas and Modelcraft present a tribute to the "Harvard"/"T-6" family and wish to give aviation lovers and enthusiasts alike the opportunity to increase and enrich their collection. This kit is made possible by close co-operation between Ocidental Replicas of Portugal and Modelcraft, and through the kind assistance of David C. Fletcher and Doug MacPhail through their book "*HARVARD! The North American Trainers in Canada*".

Visit **Modelcraft** on the web at www.modelcraft.com.

© 1998 **MODEL CRAFT**, Burnaby, B.C., V5G 4J9

Phone: (604) 437-1166

Printed in Canada.

1

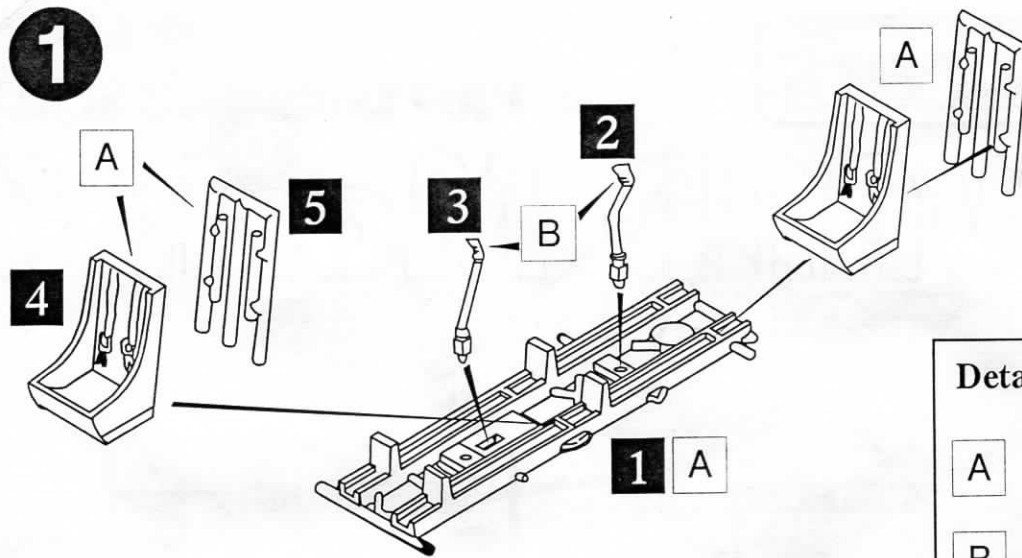

Detail Painting Codes

- A** Zinc Chromate Green
- B** Matte Black
- C** Matte Aluminum
- D** Steel

2

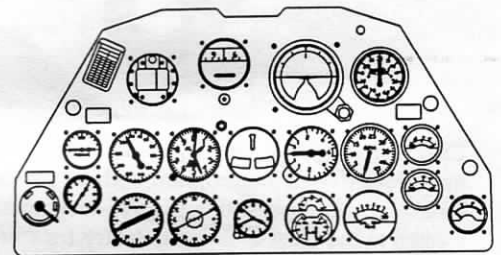
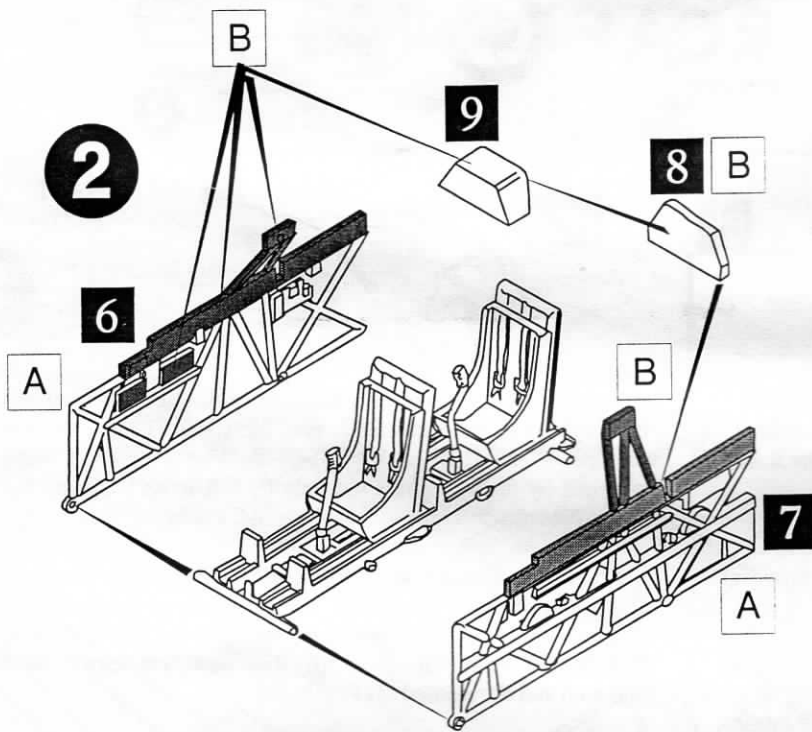

Instrument Panel Detail

3

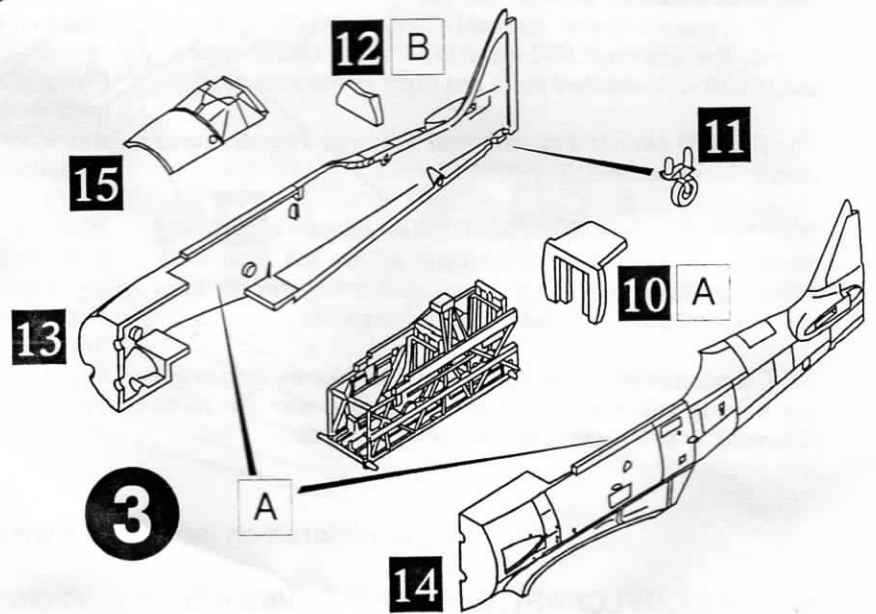

4

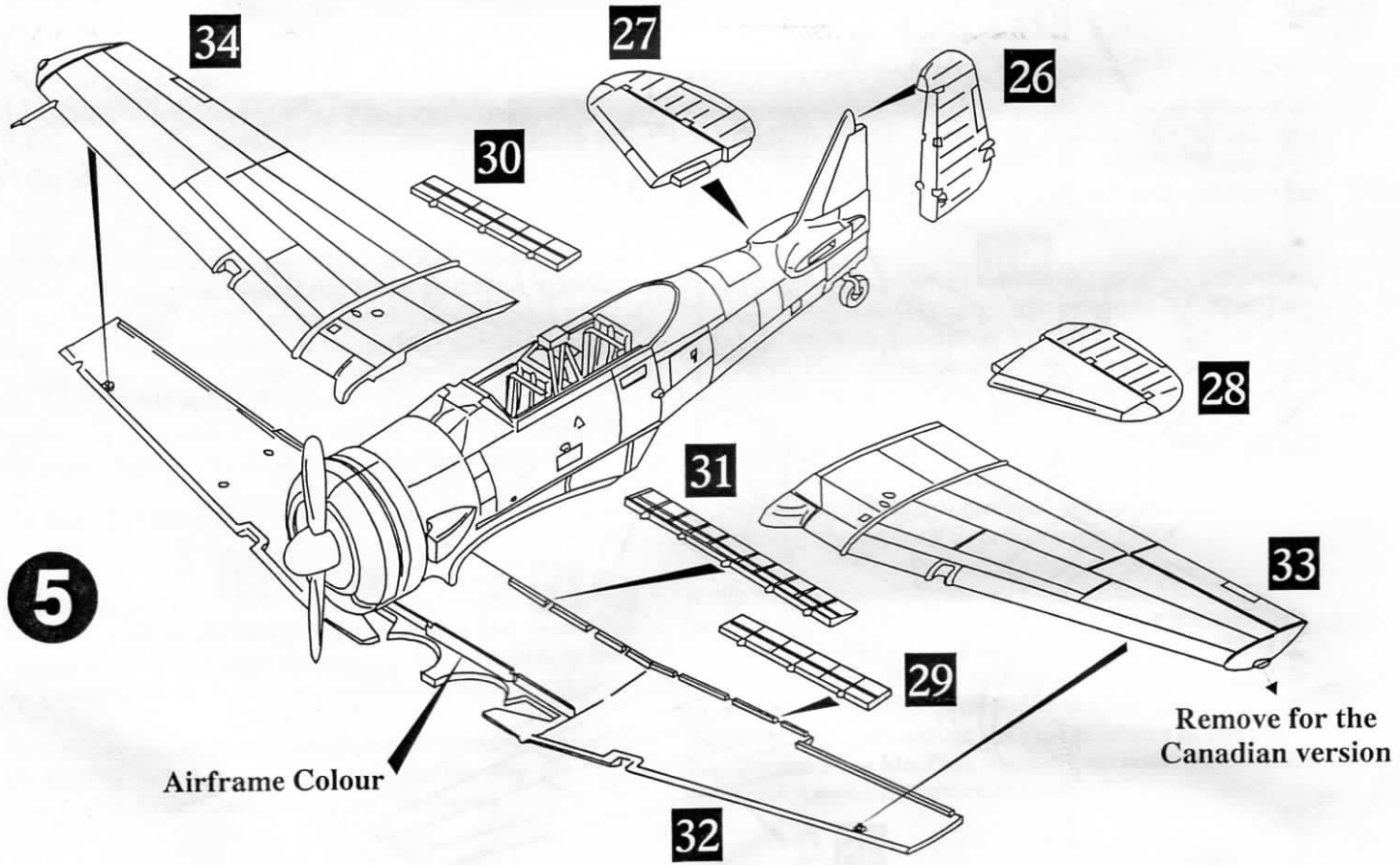
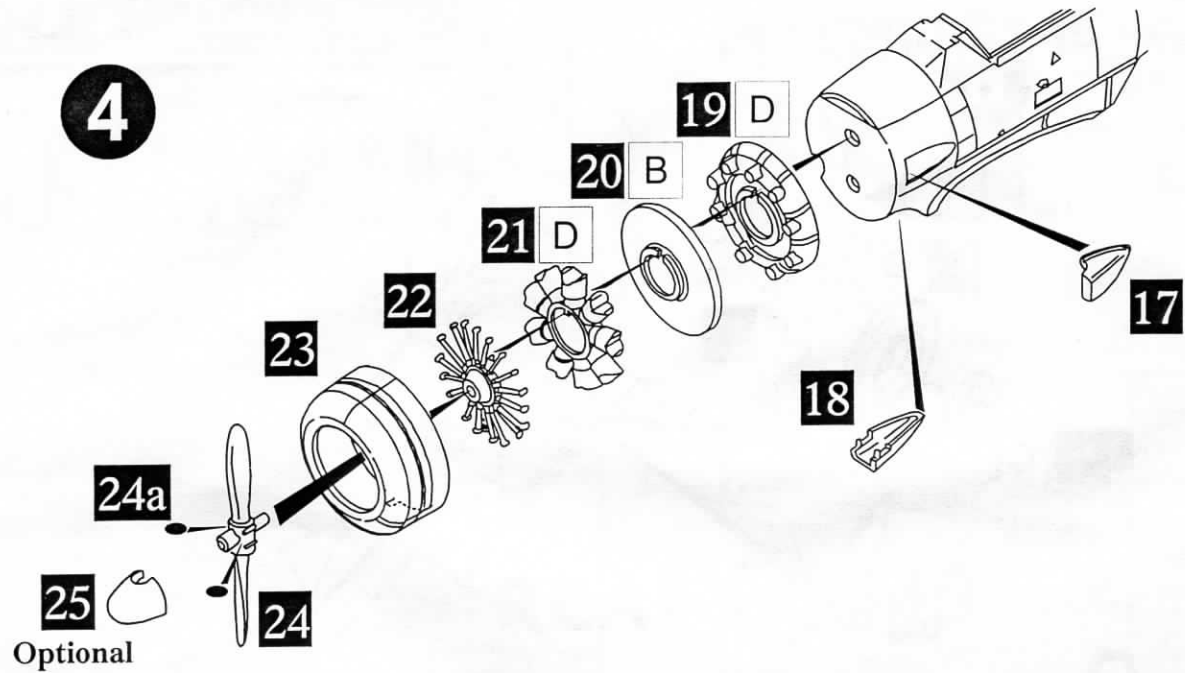

5

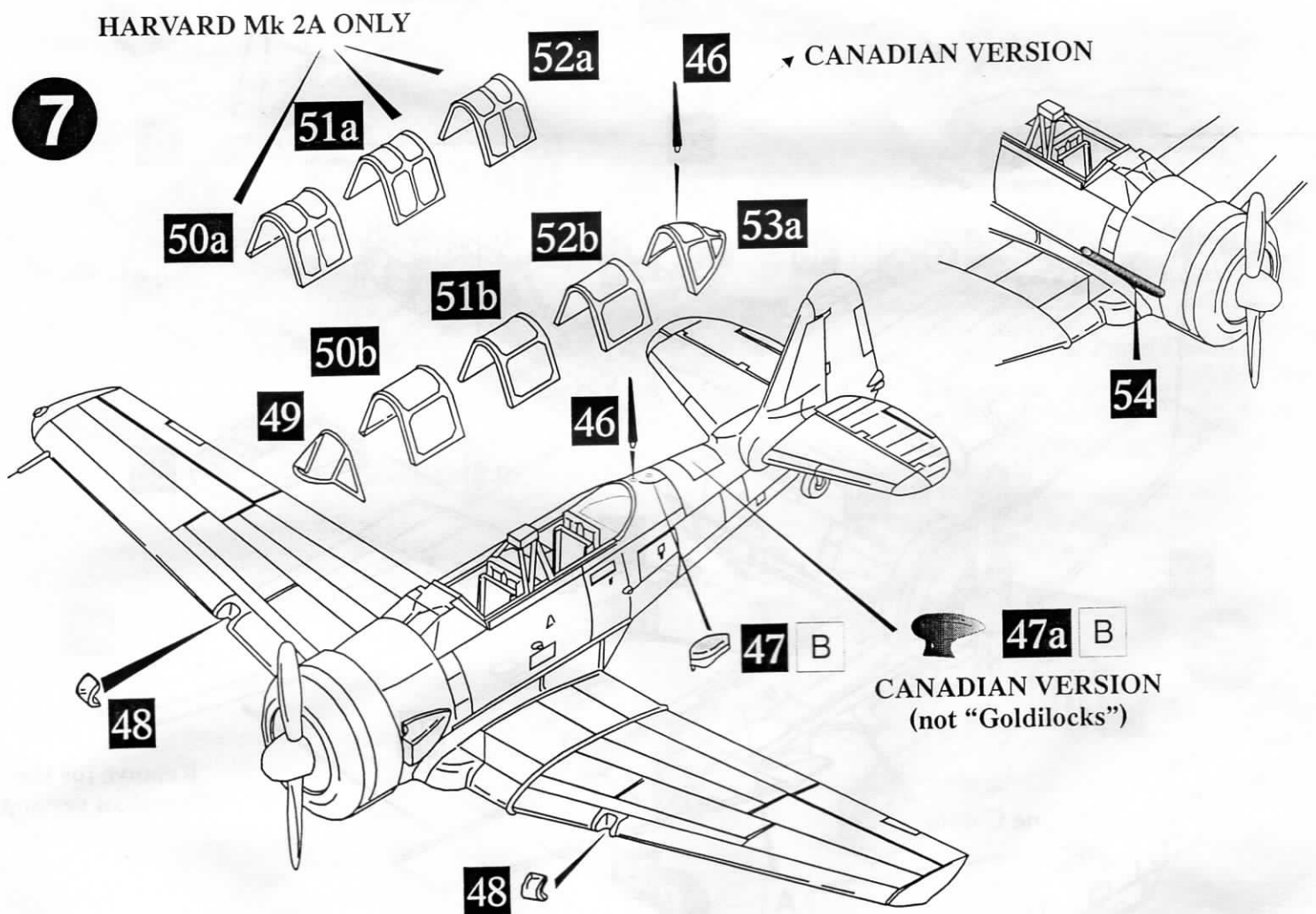
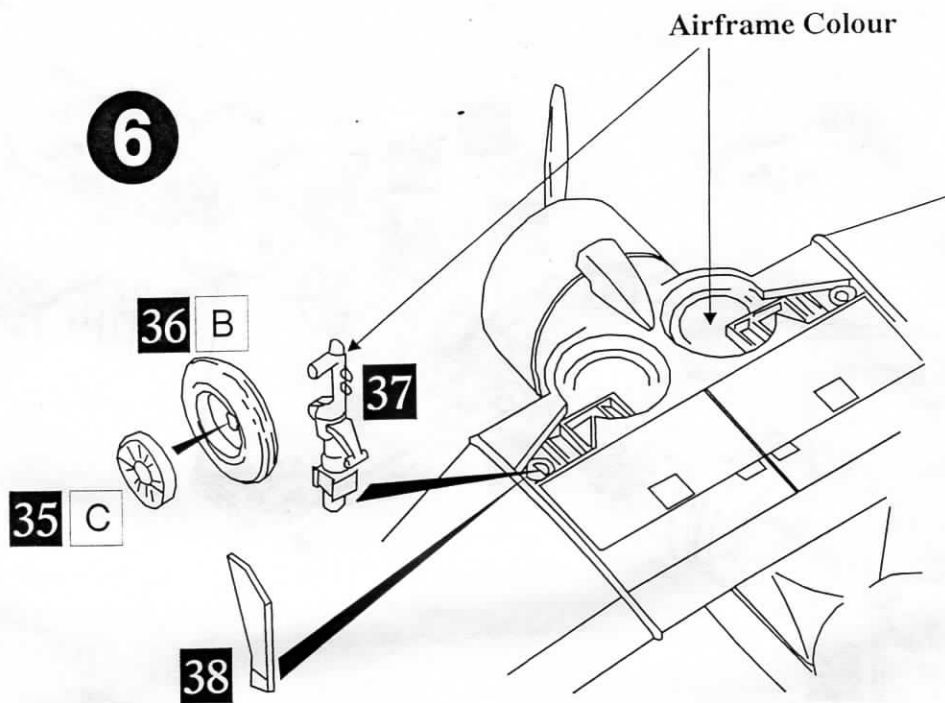

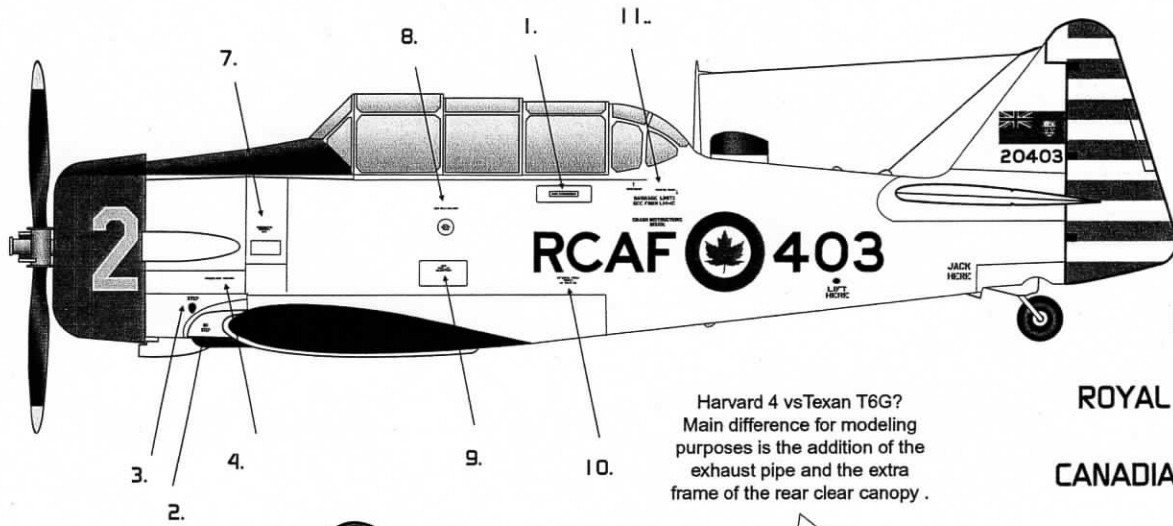

HARVARD MK4
OF THE:
ROYAL CANADIAN AIR FORCE
BUILT BY:
CANADIAN CAR & FOUNDRY LTD.

Harvard 4 vs Texan T6G?
Main difference for modeling purposes is the addition of the exhaust pipe and the extra frame of the rear clear canopy.

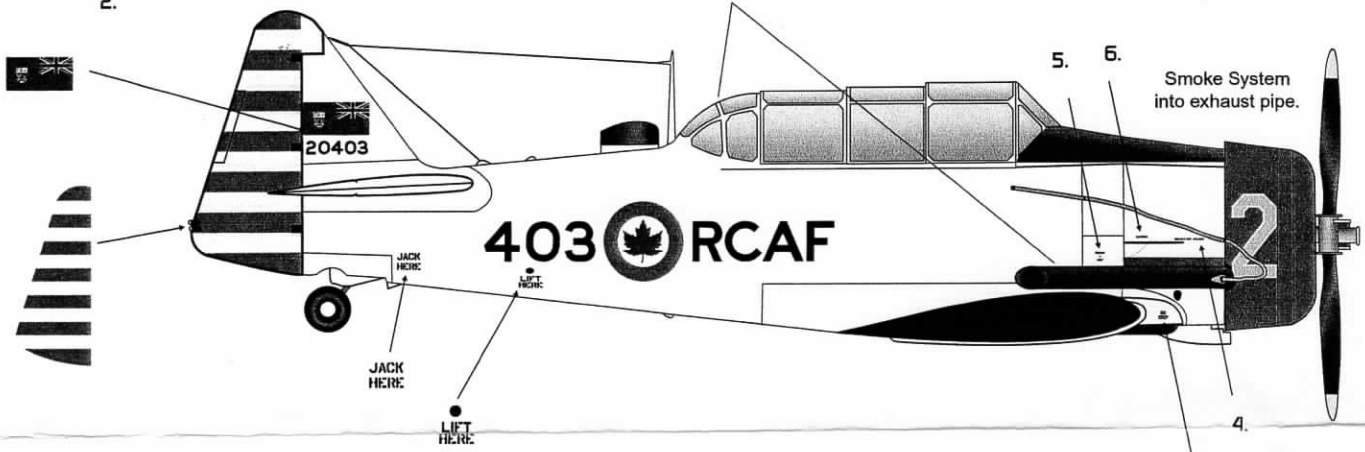

Any one of the seven aircraft can be represented.
Cut supplied codes and rearrange to do aircraft #s 3, 5, and 6.

403
459
421
372

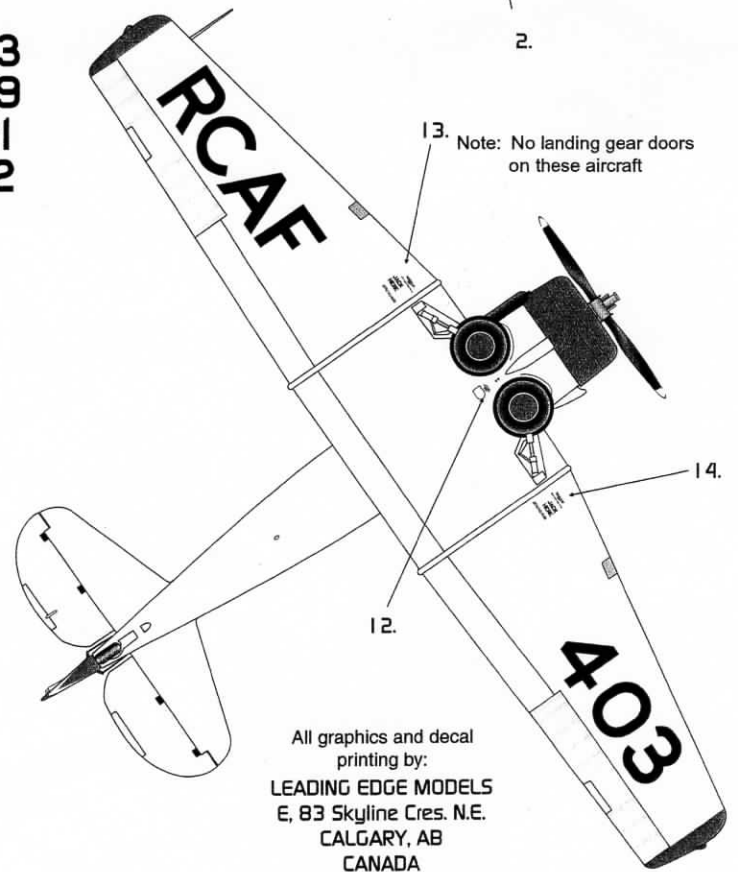
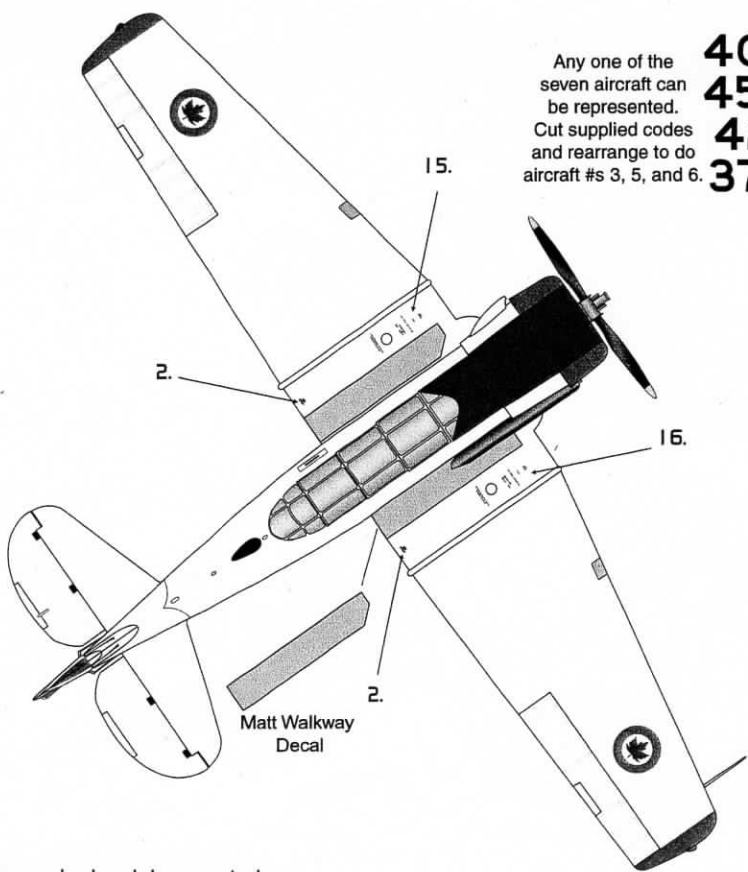

All graphics and decal printing by:
LEADING EDGE MODELS
E, 83 Skyline Cres. N.E.
CALGARY, AB
CANADA
www.lemdecal.com

RCAF HARVARD MK4 "THE GOLDILOCKS"

DECAL SET # 72.21 1/72 SCALE
48.18 1/48 SCALE

Leading Edge
MODELS

"THE GOLDILOCKS" DISPLAY TEAM 1964

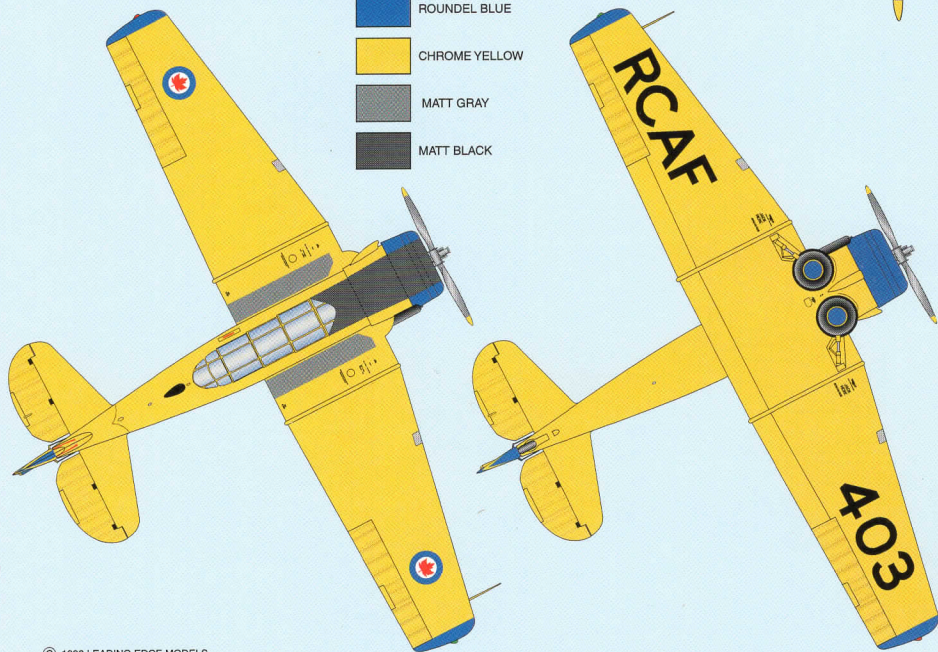
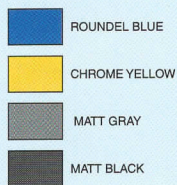
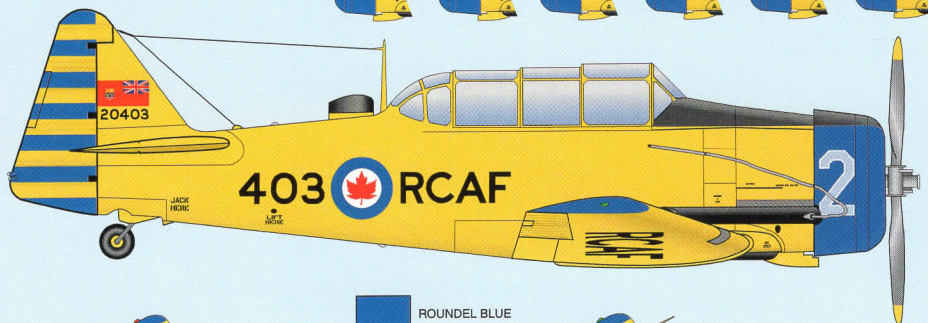
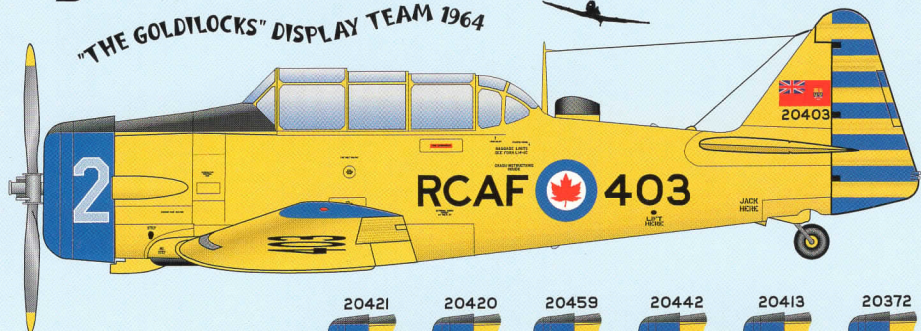

© 1998 LEADING EDGE MODELS

RCAF HARVARD MK4 GOLDILOCKS TEAM
DECAL SET #48.18 (MODEL CRAFT EDITION)

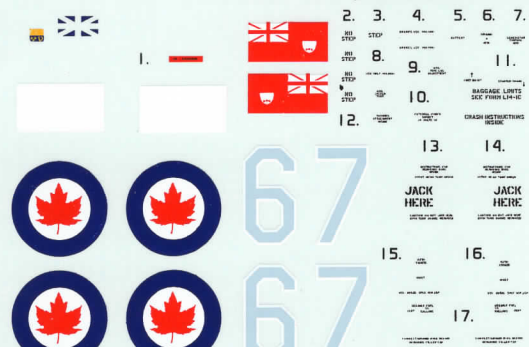

© 1998 LEADING EDGE MODELS
PRINTED IN CANADA