

SCALE
1/48
F-117A

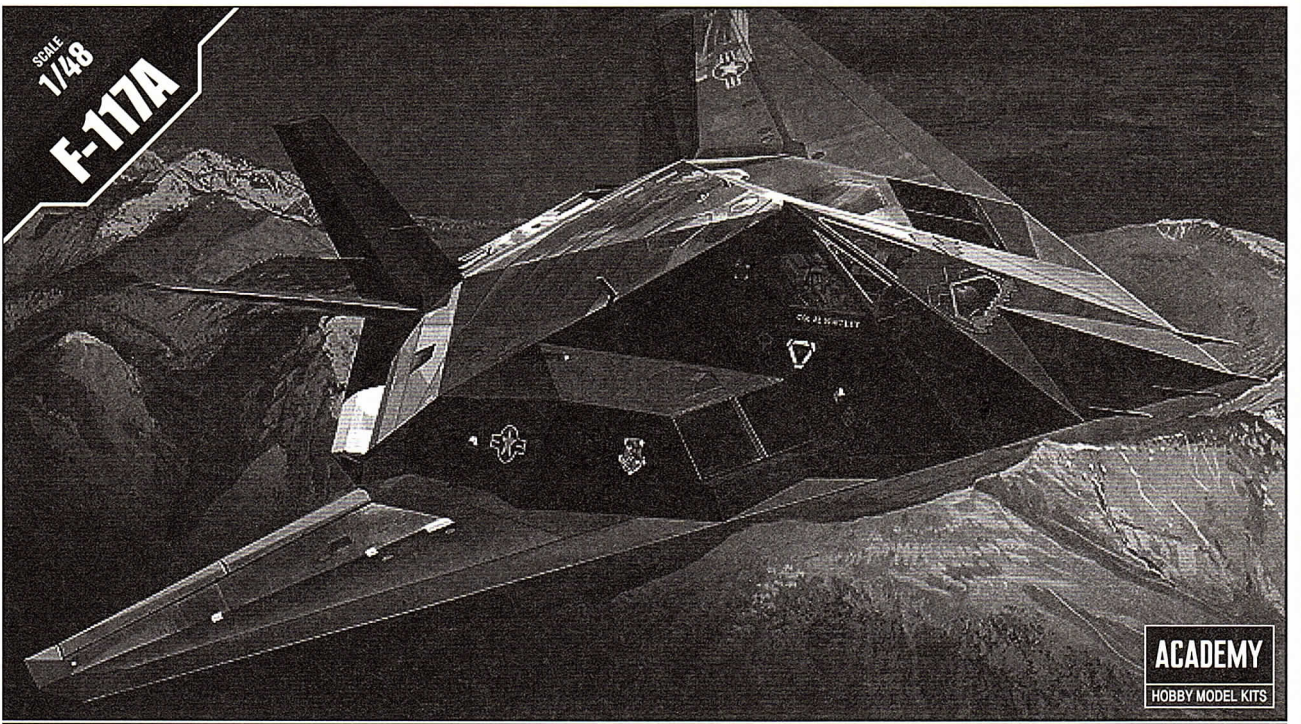

ACADEMY
HOBBY MODEL KITS

점착한다. Cement parts Coller Kleben Pegar Incollare Colar Kleven	점착하지 않는다. Do not cement Ne pas coller Nicht kleben No pegar Non incollare Nao colar Niet kleven	중복된 조작한다. Repeat operation Répéter l'opération Vorgang wiederholen Repetir la operación Ripetere Repetir a operacão Herhalen	전사지를 붙인다. Decals Décalcomanies Abziehbild	무게 추를 붙인다. Add weight Léger Gewicht	구멍이나 손톱을 메워준다. Use filler Massifquer Schließen
잘라낸다. Cut away Couper Schneiden Cortar Tagliare Cortar Snijden	선택한다. Optional parts Choix Auswahlmöglichkeit Election Scelta Opção Keuze	반대쪽도 조작한다. Repeat for opposite side Répétition de la page Wiederholung für gegenüberliegende Seite	구멍을 뚫어준다. Make hole Faire un trou Öffnen	주의한다. Be careful Faire attention Hiar Vorsicht	색칠 및 전사지 붙이기 번호 Painting scheme number Numeros de la lista de pinturas Lackierschemanummer

12265

<READ THIS BEFORE YOU BEGIN>

- Study the instructions before assembling. - Check the fit of each piece before cementing into place.
- Do not use too much cement to join parts. - Never use cement or paint near open flame.
- Open a window or make area well ventilated when cement or paint is in use.
- Tear up and throw away the empty plastic bags to avoid danger of suffocation for little children.

<ALLGEMEINE HINWEISE>

- Die Anordnung der Bauteile ist aus den Zeichnungen der Anleitung ersichtlich.
- Die Teile vor dem Verkleben ungeleimt zusammenhalten, um ihren paßsitz zu prüfen.
- Klebstoff nicht zu dick auftragen. - Klebstoff und Farben niemals in der Nähe einer Flamme verwenden.
- Während der Bemalung mit Spritzpistole oder Pinsel für frische Luftzufuhr, z.B. öffnen des Fensters, sorgen.
- Bausatz von kleinen Kindern fernhalten. Verhüten Sie, daß Kinder irgendwelche Bauteile in den Mund nehmen oder Plastiktüten über den Kopf ziehen.

■ 조립하기 전에

- 부품을 조립하기 전에 설명서를 잘 읽어 후 조립한다. -부품을 자를 때는 칼이나 니퍼로 깨끗이 잘라준다. -접착제를 사용할 곳과 사용하지 않는 곳에 주의하고 너무 많이 바르지 않도록 한다.
- 접착하기 전에 부품을 맞추어 확인한 후 조립한다. -에나멜 페인트나 접착제를 사용할 때는 창문을 열어 환기를 시키고 화기를 멀리한다. -사용 후 남은 부품은 어린 아이들의 손에 닿지 않도록 잘 처리한다.



<LISEZ CE QUI SUIT AVANT DE COMMENCER LE MONTAGE>

- Etudier les schémas d'assemblage. - Contrôler que chaque pièce soit bien conforme avant de la coller à sa place.
- N'utilisez pas trop de colle pour réunir les pièces. - Ne faites manipuler la colle ou peinture à proximité d'une flamme.
- Aérer soigneusement la pièce où vous peignez(ouvrir la fenêtre).
- Après avoir sorti les pièces du sac en plastique, déchirer le sac afin d'éviter que les enfants ne le mettent sur la tête et ne s'étouffent.

<組み立てる前に>

- 組み立てる前に説明書をお読み下さい。 -部品をランナーから切りはなす時は模型用ニッパーとカッターを使用します。
- 接着剤を少なめに使うことがきれいに仕上げるコツです。 -接着する前に部品を合わせて確かめます。
- 接着剤や塗料を使用する時はときどき窓を開けて換気をお願いします。
- 組み立て後の部品やビニール袋は小さな子供の手の届かない安全な所に保管して下さい。

▲ 보호자 분들은 반드시 읽어 주십시오.



주의
WARNING!

- 조립하기 전에 취급 설명서를 꼼꼼히 읽어 내용을 충분히 이해한 상태에서 조립하여 주십시오.
- 부품을 자를 때는 해당번호를 확인한 뒤 니퍼 등으로 깨끗이 잘라 주십시오. 칼을 이용하여 부품을 다듬고 자를 경우 손을 다치지 않도록 세심한 주의를 기울여 주십시오.
- 작은 부품 따위를 절대 입에 넣지 마십시오. 잘못하여 삼킬 경우 질식 등의 위험이 있습니다. ● 자칫 먹을 우려가 있으므로 3세 미만의 어린이에게는 절대로 주지 마십시오.
- 잘라낸 부품은 깨끗이 다듬어 조립하고 남은 쓰레기는 분리하여 잘 버려 주십시오. ● 기능상 부어오른 부분이 있을 수 있습니다. 취급 시 충분한 주의를 기울여 주십시오.
- 제품 및 부품이 포장된 비닐봉지는 개봉 후 즉시 어린이의 손에 닿지 않는 곳에 잘 버려 주십시오. 머리에 뒤집어쓰거나 얼굴을 덮을 경우 질식의 위험이 있습니다.
- 색칠 및 접착을 위하여 모형을 도료 및 접착제 등을 사용할 때에는 창문을 열어 환기를 시키고 화기를 멀리하여 주십시오. 사용하고 남은 도료 및 접착제는 어린이의 손이 닿지 않는 곳에 잘 보관하여 주십시오.
- Before starting to assemble, read the instruction manual very carefully to understand well everything of the instructions.
- Before cutting a part off sprue, check the part number again and use proper tool such as nipper to cut it clearly. Take care not to be hurt in use of modelling knife to cut or trim parts.
- Never put small parts in the mouth to avoid any danger of suffocation by accidentally swallowed ones. ● Never let children less than 3 years old have it to avoid any danger of taking it.
- The product may have some protruding parts for functional reasons and take care of handling it always.
- After cutting a part off sprue, trim it clearly to assemble and the wastes should be properly sorted to dispose.
- Plastic bags packed with the product and parts should be disposed in a proper place immediately to keep out of children to avoid any danger of suffocation by pulling it over head or putting it over face.
- Before using modelling colors or cement, open windows to keep the room well ventilated and do not use near fire or flame. After using them, keep in a proper place out of children.

1

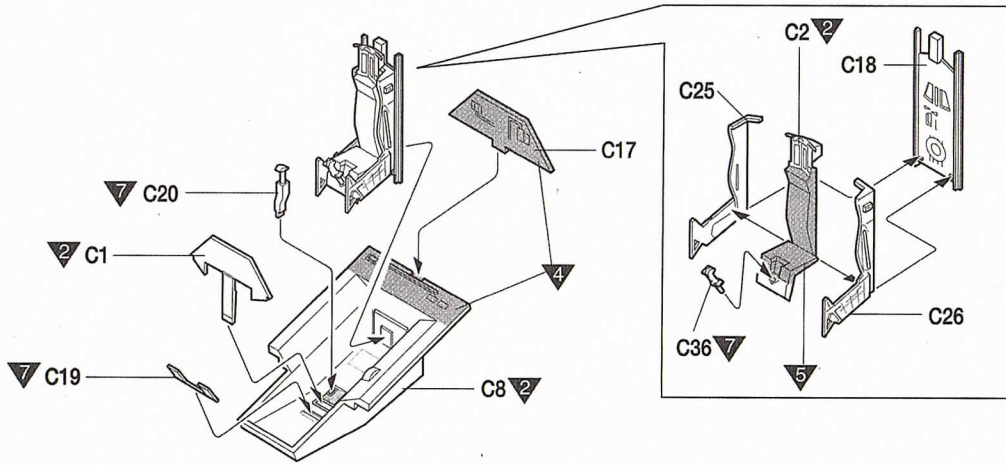

2

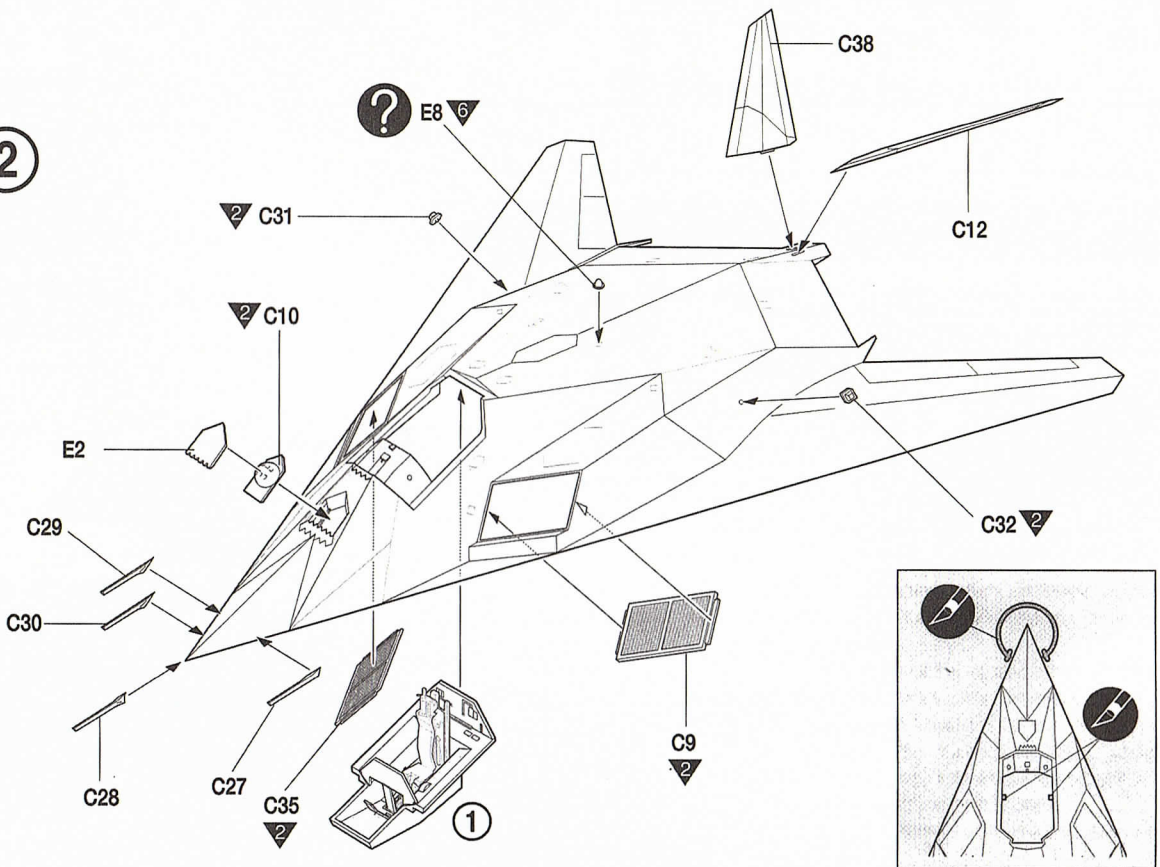

3

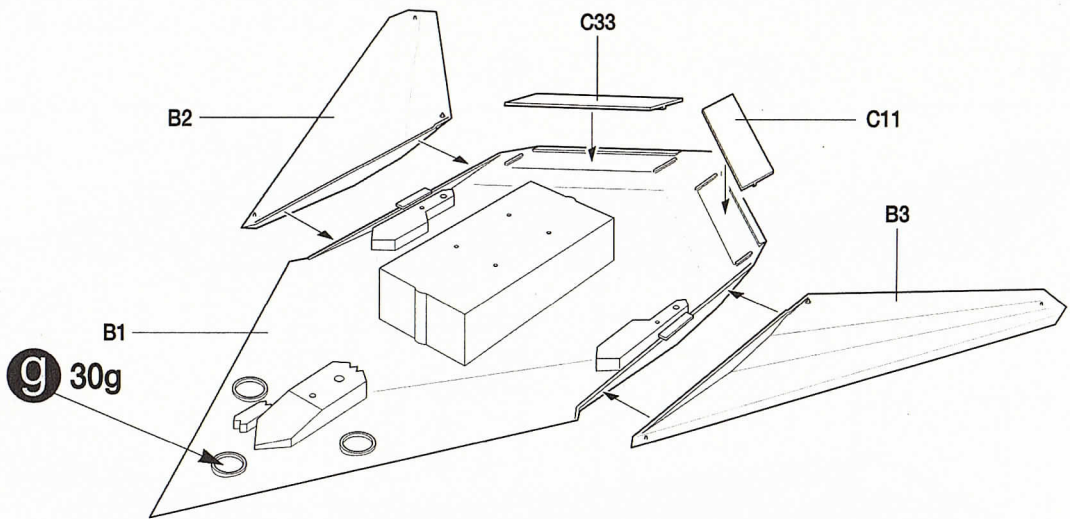

4

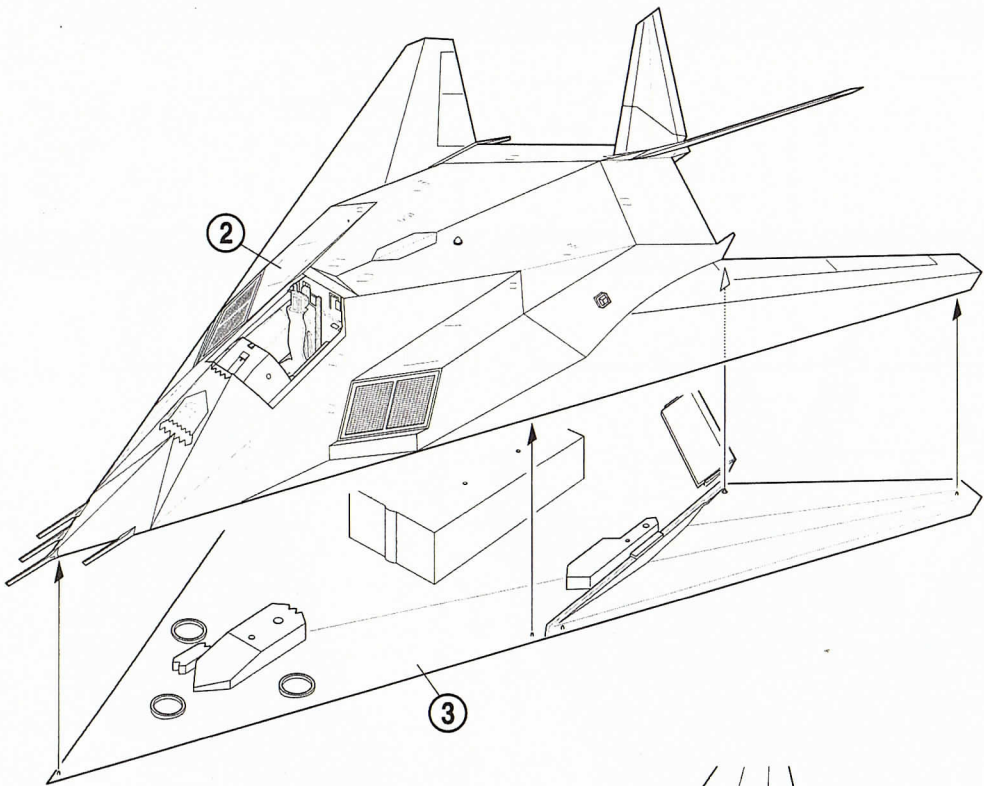

5

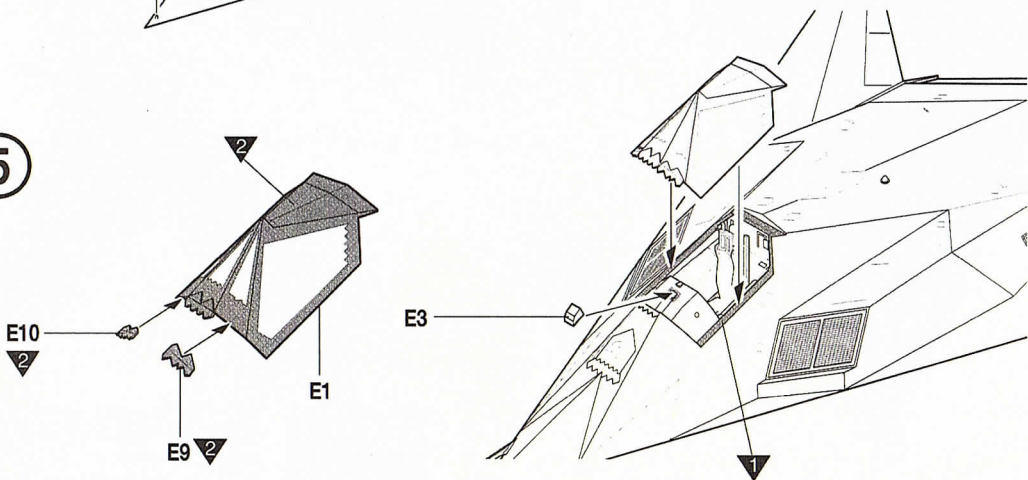

6

※ C15, C16, C22, C23, C24:	Inside Innenseite	▼
	Intérieur	▼
	內側	▼
	내측면	▼

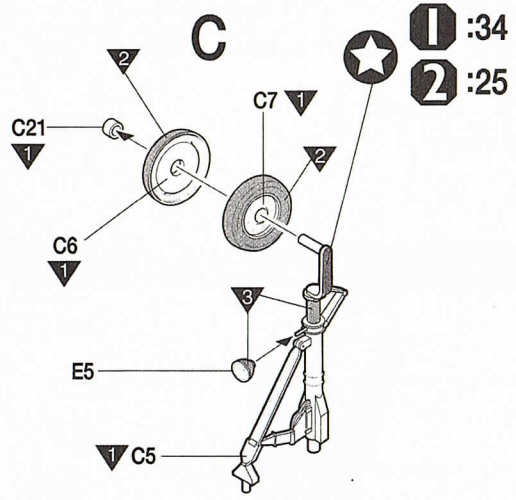
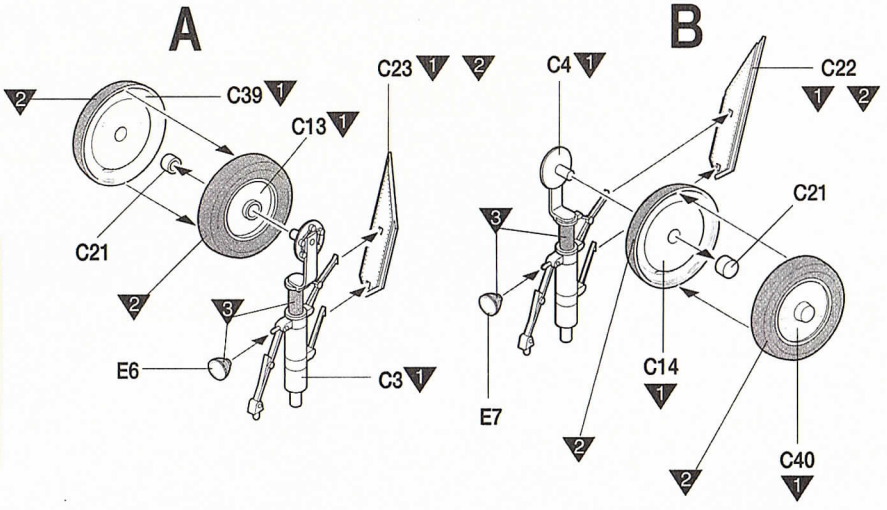
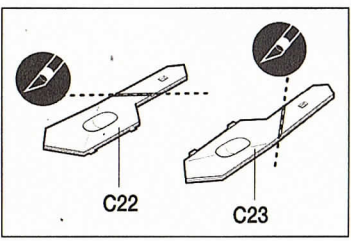

7

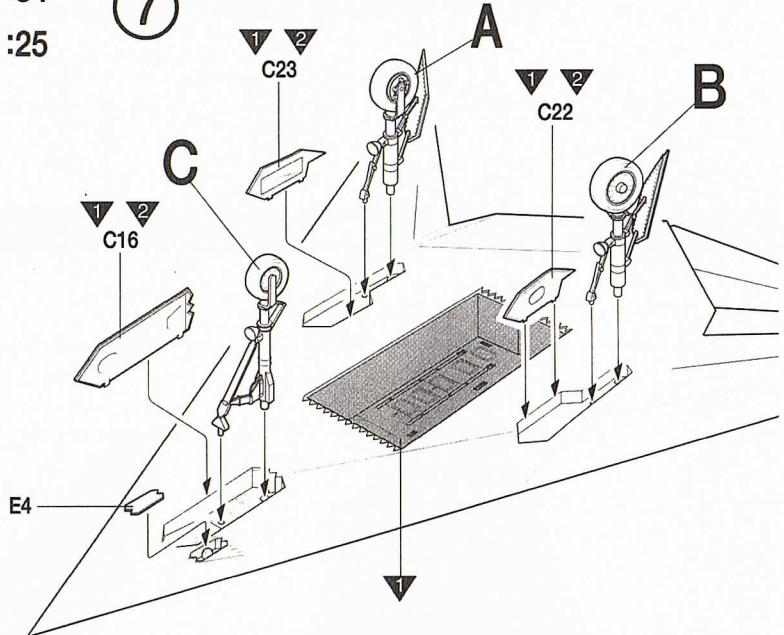

8

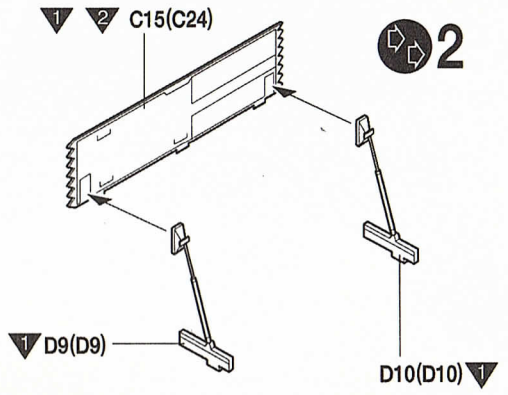
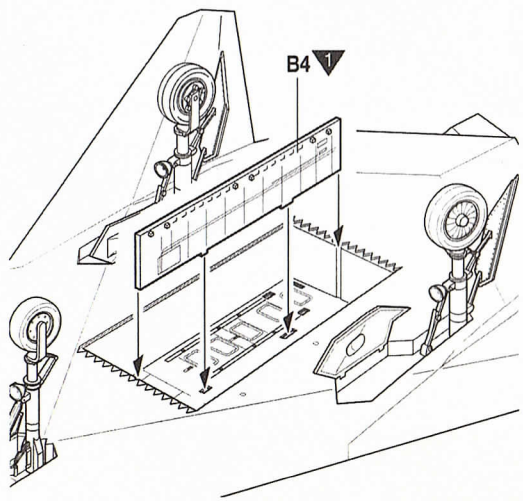

9

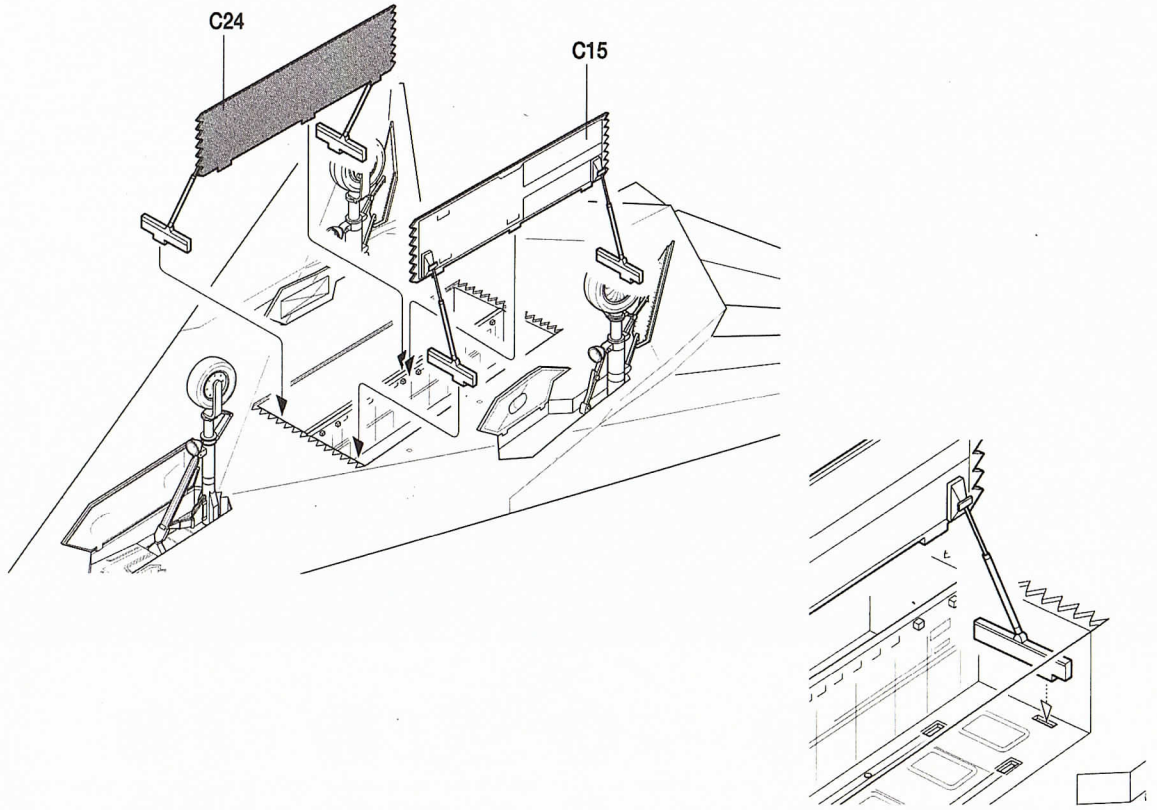

10

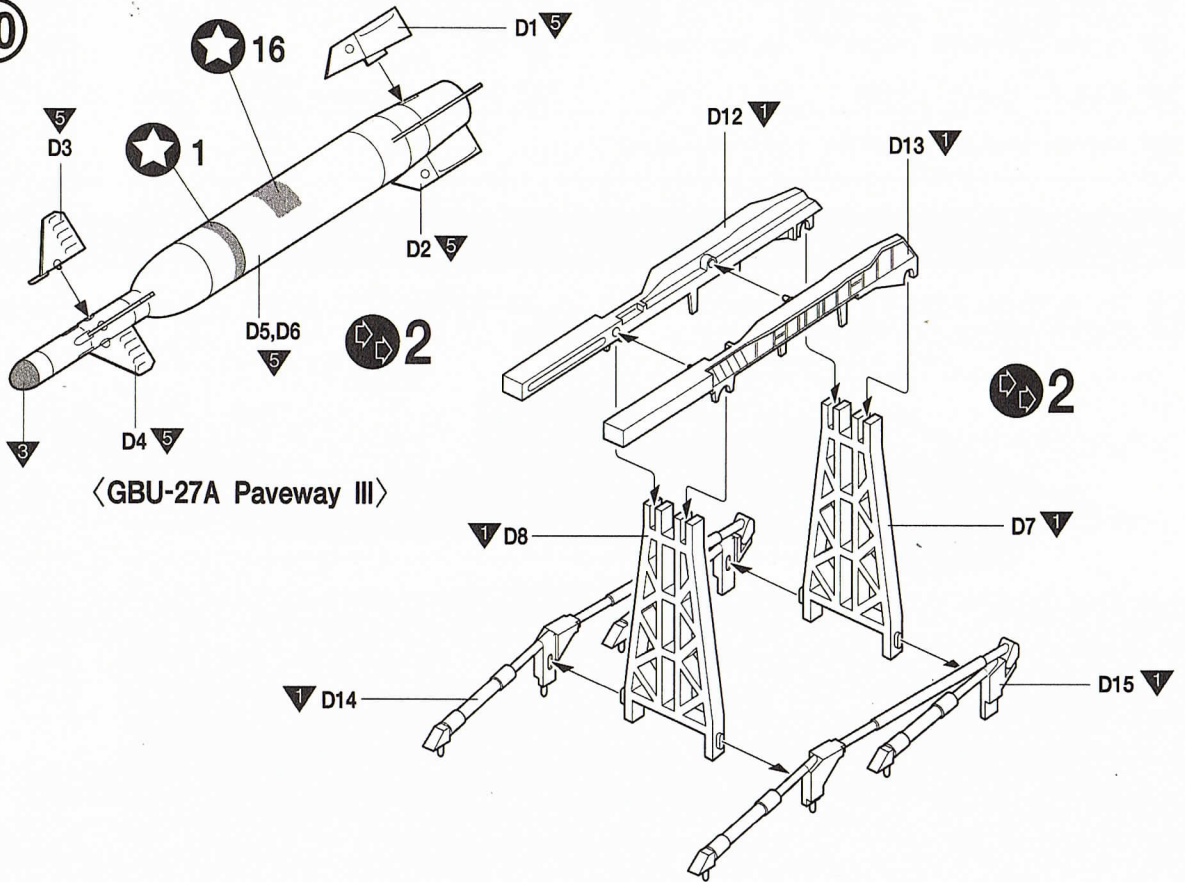

11

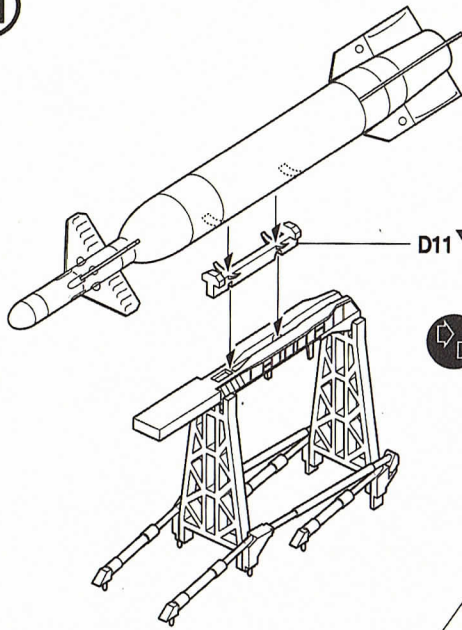

2

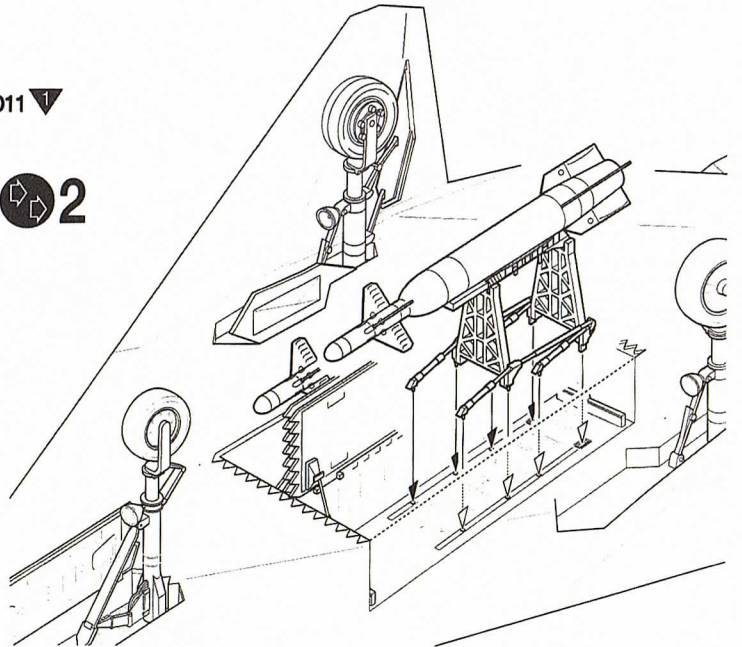

1	FLAT WHITE	MATTWEIß	BLANC MAT	つや消しホワイト	무광 흰색	5	OLIVE DRAB	BRAUNOLIV	BRUN OLIVE	オリブドラブ	국방색
2	FLAT BLACK	MATTSCHWARZ	NOIR MAT	つや消しブラック	무광 검정색	6	RED	ROT	ROUGE	레드	유광빨강색
3	SILVER	SILBER	ARGENT	실버	은색	7	METALLIC GRAY	METALLGRAU	GRIS MÉTAL	메탈릭그레이	흑철색
4	NEUTRAL GRAY	MITTEL GRAU	GRIS MOYEN	뉴트랄그레이	뉴트랄 그레이						

■ Painting & Decal placement 색칠 및 전사지 붙이기

I Col. Al Whitley, 37th TFW "Toxic Avenger" No.813 第37戰術戰鬥航空團 813號機, 알-피트리 대좌
제37전술전투항공단 813호기, 알 휘틀리 대령 탑승기

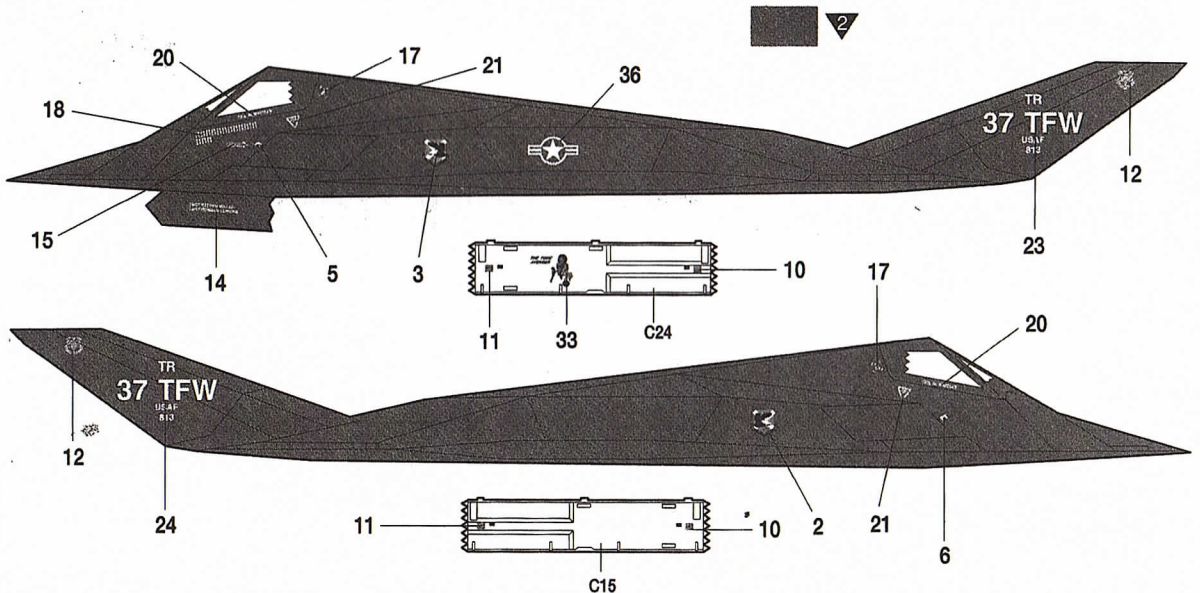

C15

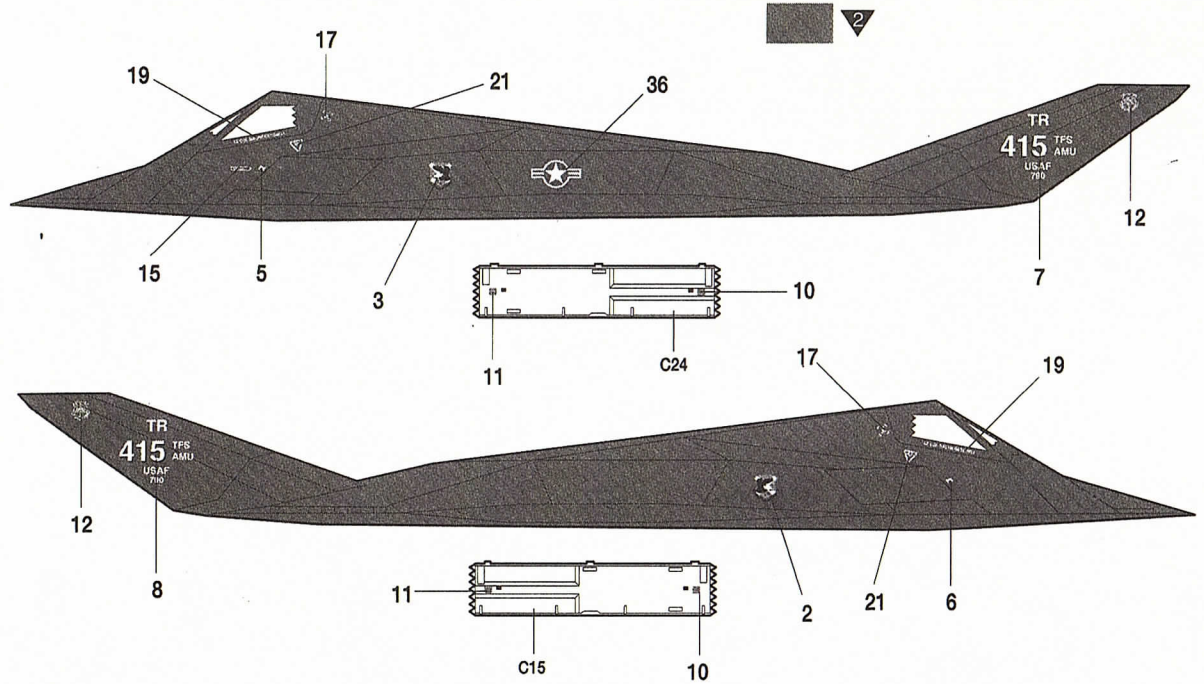

Common Markings Übliche Markierungen Marquages Communs 共通マーク 공통마킹

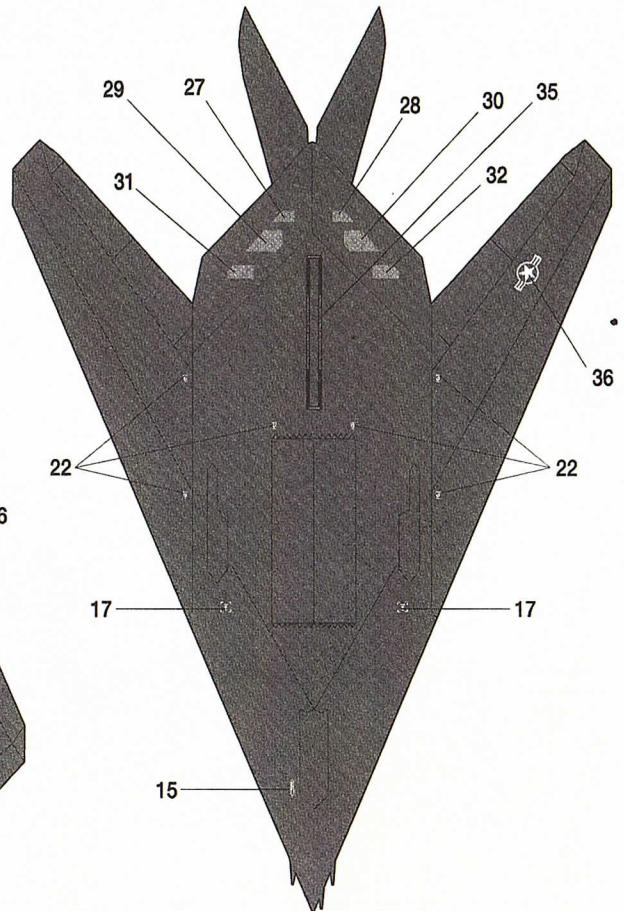
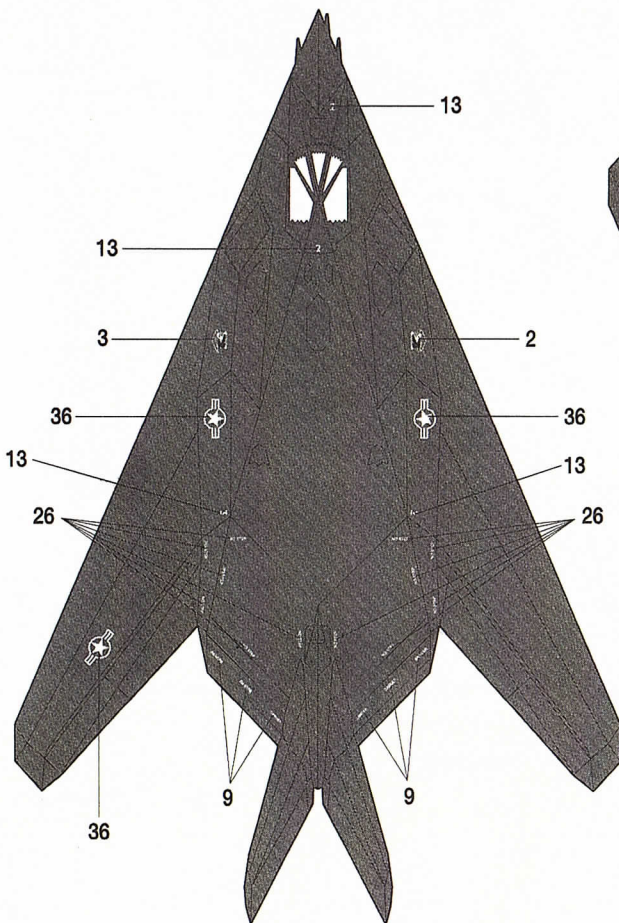

■ Parts Locating Diagram 부품도

B

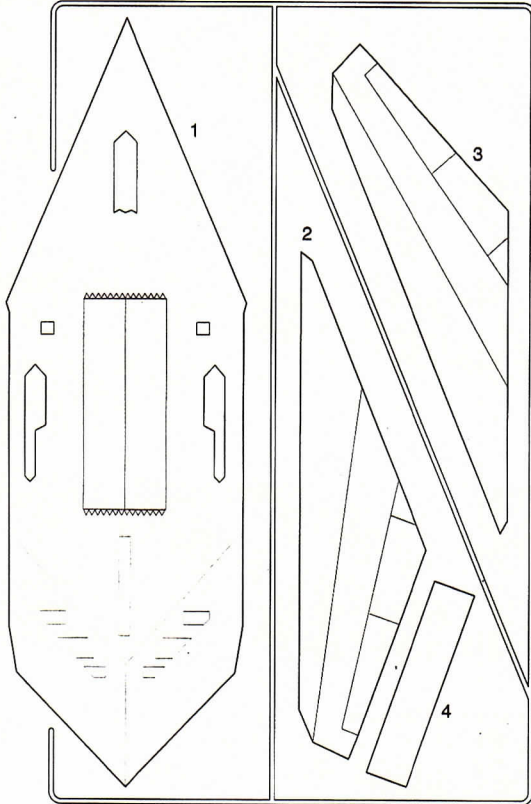

C

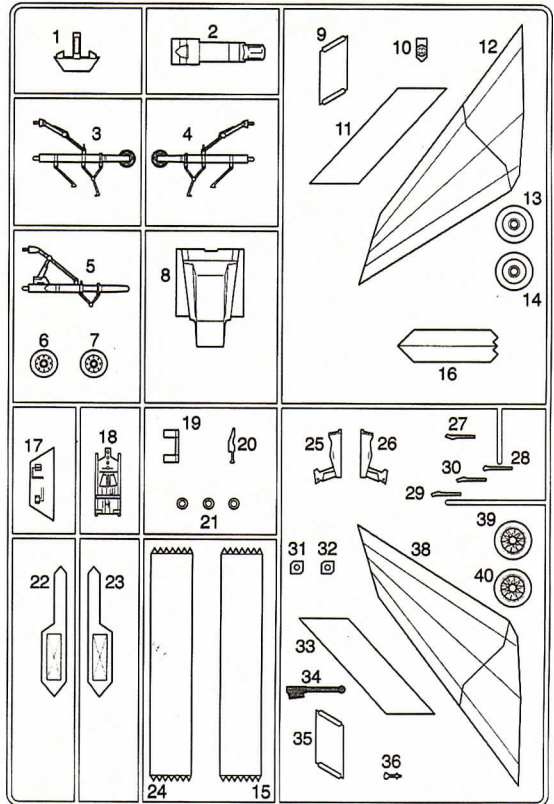

D × 2

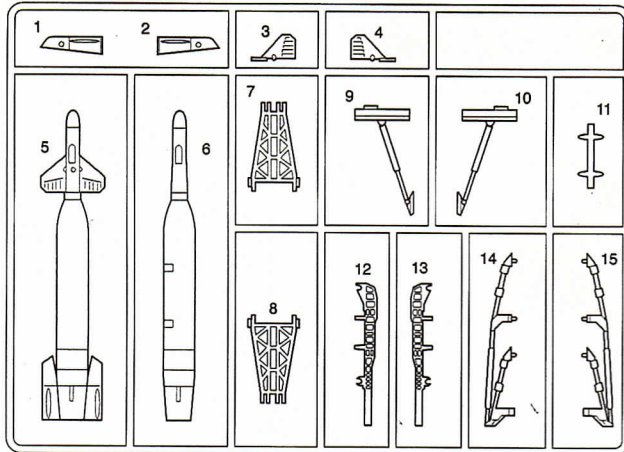

- Upper Fuselage
- 同體上部
- 동체상부

E

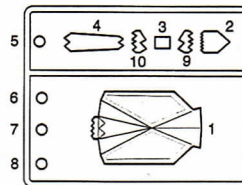

- Unused Parts
- 不必要部品 : C34
- 불필요부품

ACADEMY
HOBBY MODEL KITS

ACADEMY
ACADEMY PLASTIC MODEL CO., LTD.
521-1, Yonghyeon-dong, Uijeongbu-si, Gyeonggi-do, Korea
고객상담전화: 080-969-7000