

Das Werk
IN COOPERATION WITH BOLD DIVISION

DW35006



Einheitsanhänger 5t Baumuster E 5

H. Bu. G.K.H., den. 13. Jul. 1940

H.B.

P.H. S.D.

F.R.

Meyer
GRUNDZUGSCHAFT
und

(Dienstgrad und Dienststellung)

Einheitsanhänger 5t

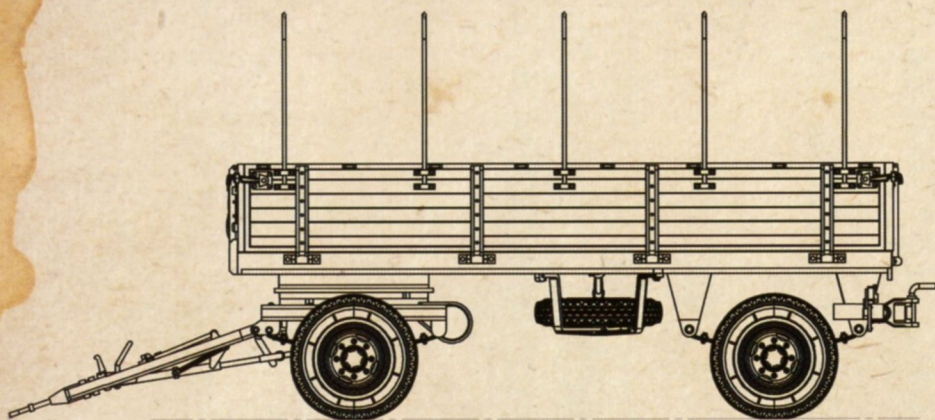

The Anhänger 5T, 5 tonne trailer, known by the official nomenclature of "Einheitsanhänger 5 t Baumuster E 5" was the standard medium military trailer of the German military throughout the second world war. With a load capacity of 5 tonnes, and an empty weight of approximately 2.5 tonnes, the Anhänger 5t could be seen hauling material anywhere the German military was active. Also utilized by the Luftwaffe and Kriegsmarine for transportation duties, the Anhänger 5t proved so rugged and useful that it continued to serve other masters well after the end of hostilities



Warning: Choking hazard. Keep small bits and pieces away from toddlers. Use paint and glue in well-ventilated areas only, away from open flame. Wear protective gear while working with knives and while sanding. Protect your lungs from dust and fumes. Beware of sharp edges.

Assembly: read the instructions carefully before starting assembly. Dry-fit parts and sub-assemblies before installing them.

Painting: Always run a paint test bed parallel to the project. Test chemical reactions and products from different brands for compatibility before combining different products on your model. Use the test bed to experiment with weathering effects as well.

Decals: Soak decals in warm water until they become loosened from the carrier film. Consider using softeners and setting solutions. Avoid trapping air bubbles under the decal. Seal decals with a clear coat after they have thoroughly dried.

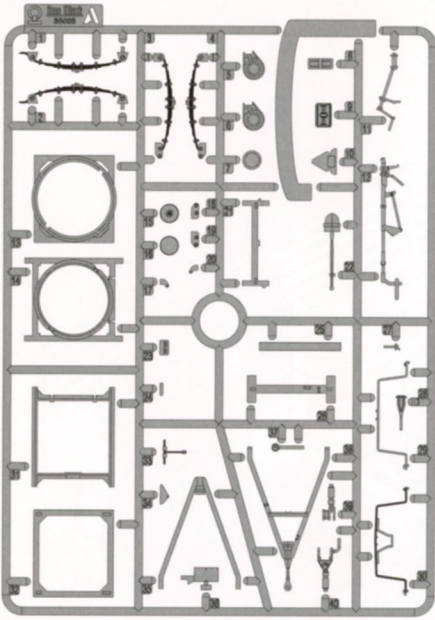

- A ...x1
- B ...x1
- C ...x1
- E ...x4
- D ...x4
- U ...x1
- T1 ..x4
- T2 .x4

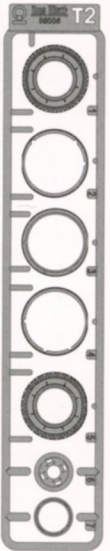
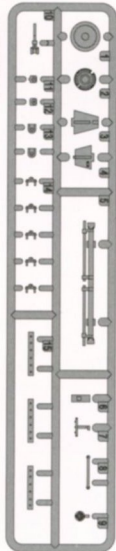
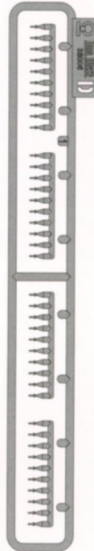
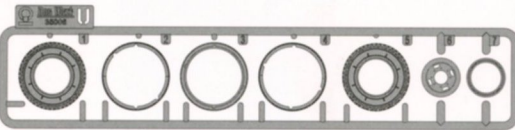
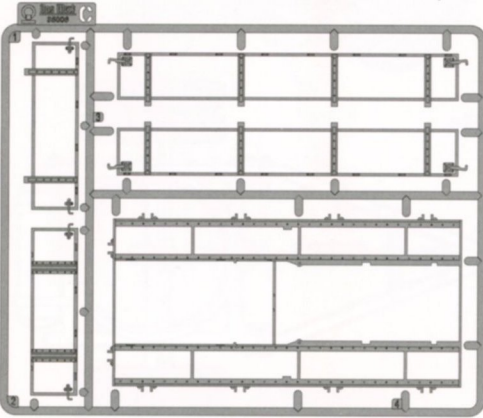
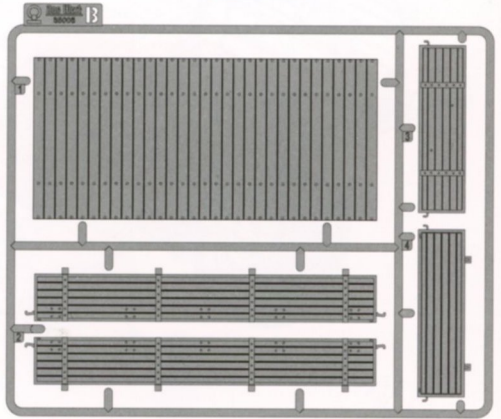

OPTION



CAUTION



REPEAT



DECALS



NO GLUE



USE LITTLE GLUE



USE CA GLUE



CHECK BOX

SECTION 1: FRONT AXLE

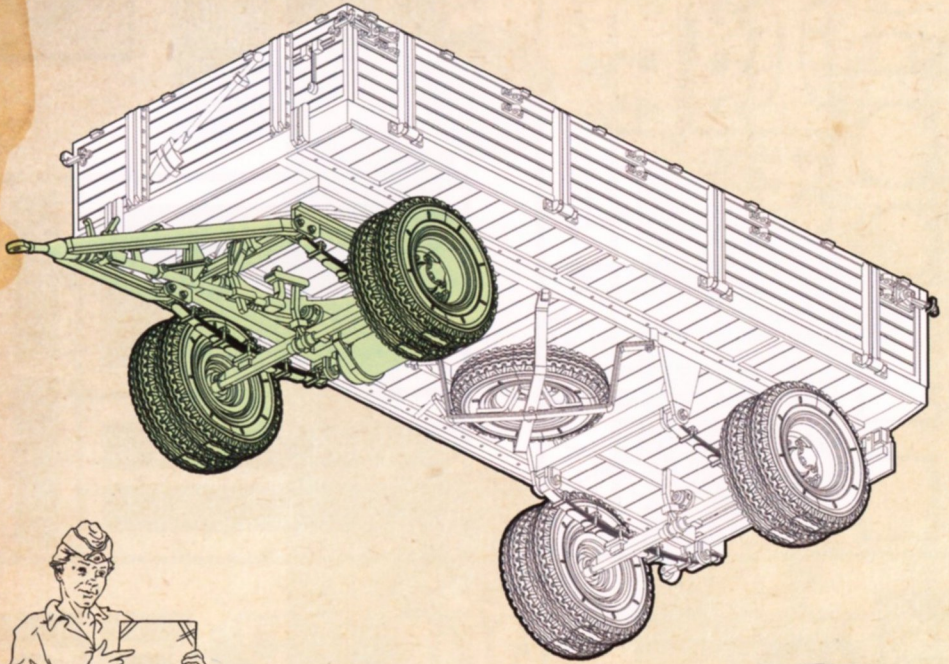

- 1: Work in a well-lit place.
- 2: Tweezers are helpful while working with small parts.
- 3: Be patient!

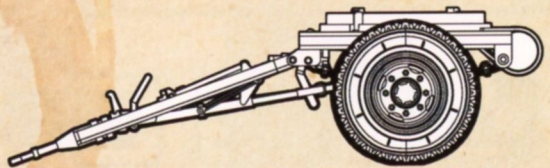
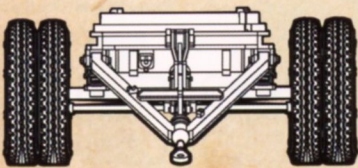
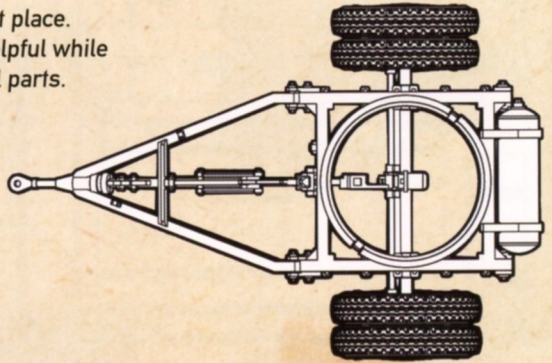



Bild 9: Radnabe, Schritt

- 9 Federullage
- 10 Achse
- 11 Bremsenträger
- 12 Bremsbacken
- 13 Bremstrommel
- 14 Bremsankerplatte
- 15 Ringelgelager, hinten

I-Gruppe	Werkzeug	Material	Bezeichnung
1.1	1.1	1.1	1.1
1.2	1.2	1.2	1.2
1.3	1.3	1.3	1.3
1.4	1.4	1.4	1.4

1.5

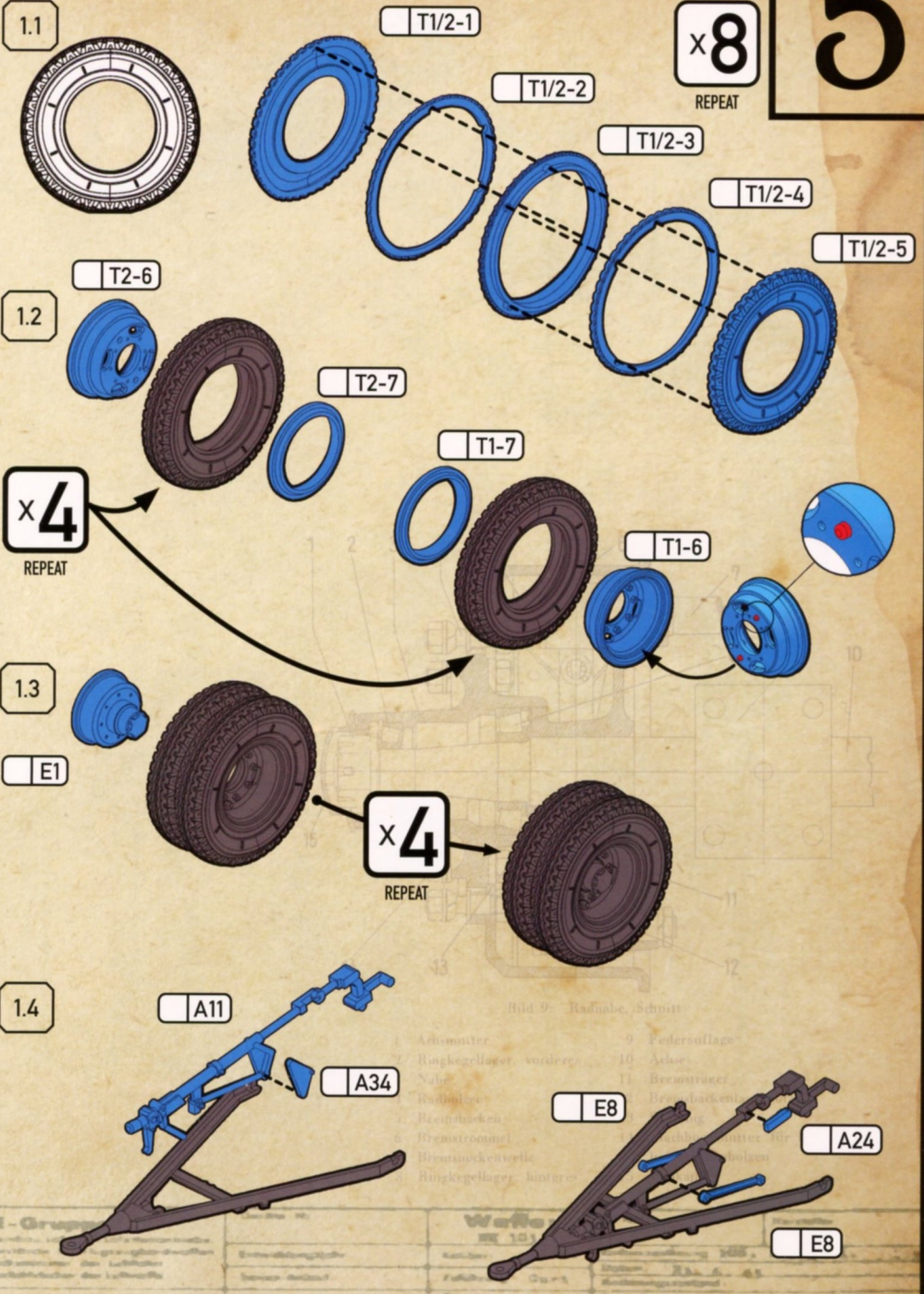
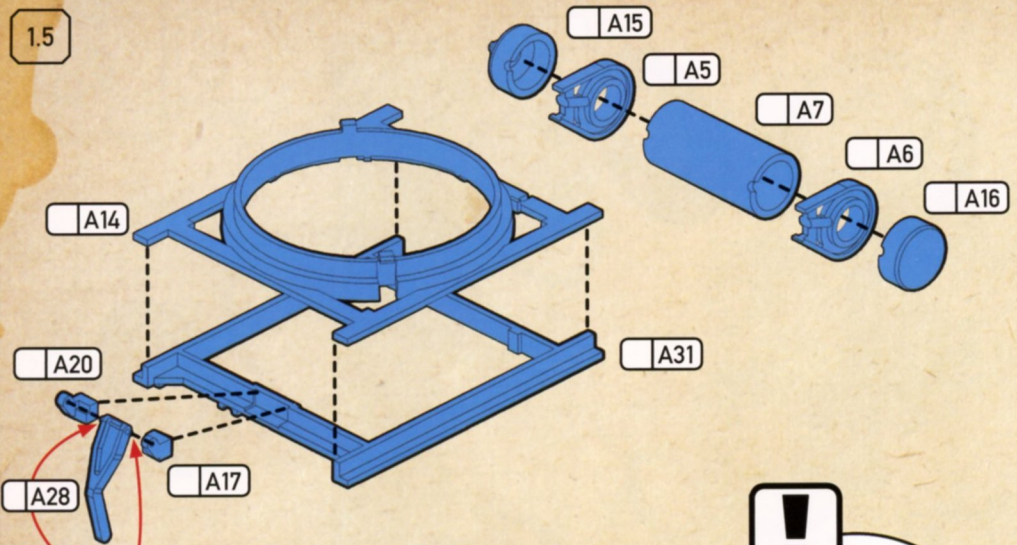

NO GLUE

1.6



CAUTION

E5

E9

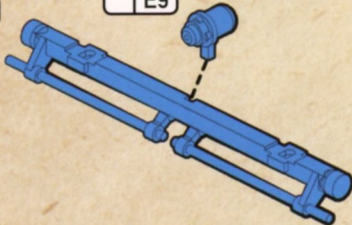

CAUTION

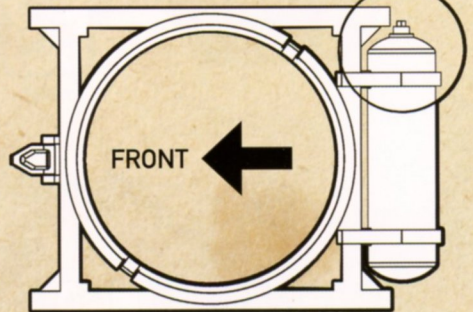
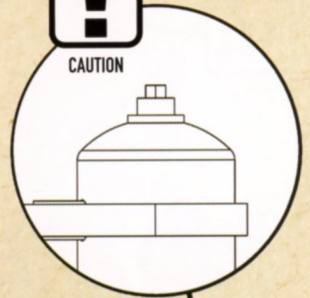

FRONT

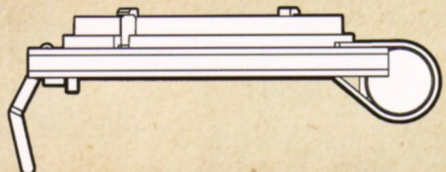

1.7

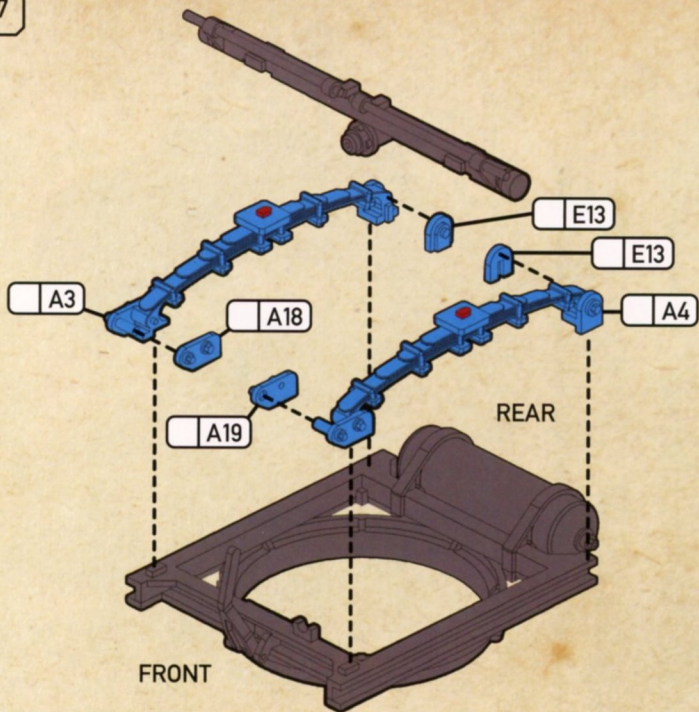

FRONT

REAR



1.8



CAUTION



NO GLUE

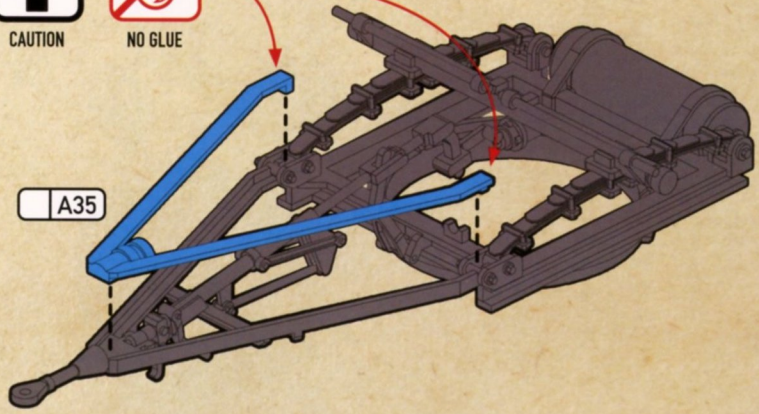

1.9

USE PART E12 IF ADDING WIRING DETAILS

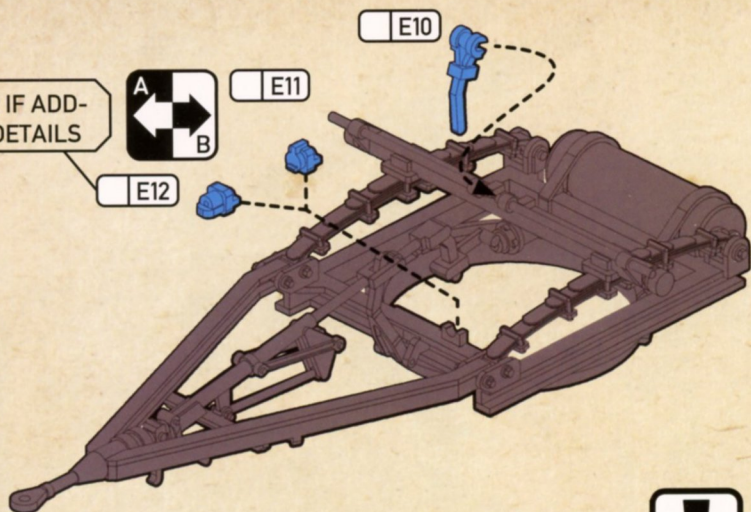

WHEELS CAN ALSO BE ADDED AT THE LAST STAGE FOR EASIER PAINTING AND ALIGNMENT

1.10

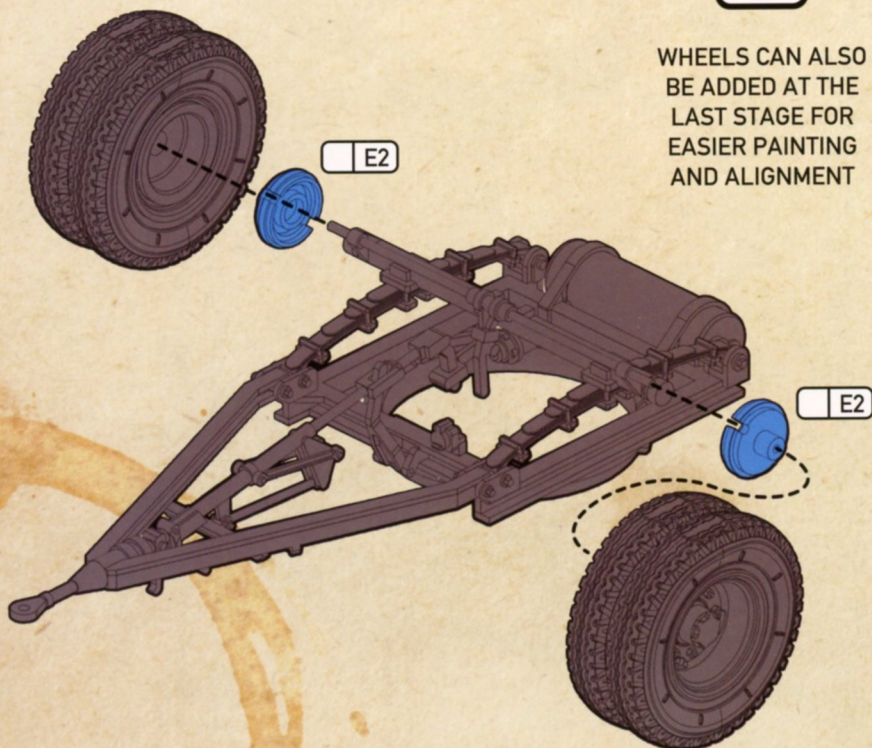

SECTION 2: REAR AXLE

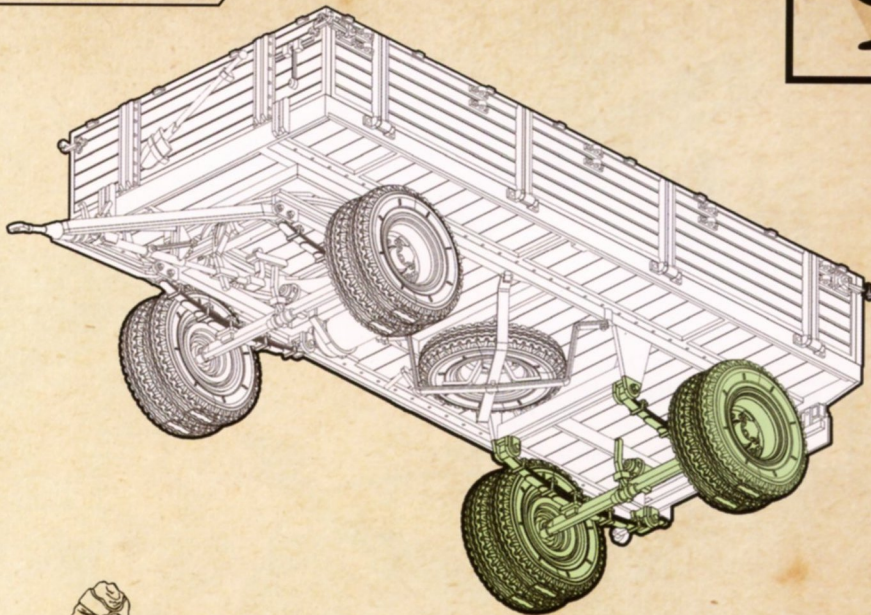

These parts can be tricky, so work slowly and patiently in a well-lit place.

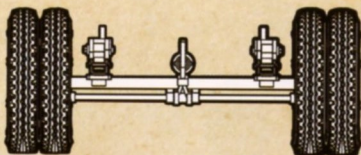
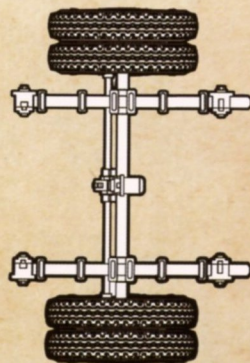

2.1

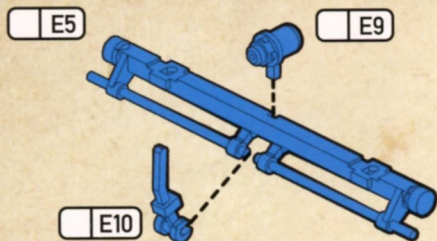

2.2



BE CAREFUL NOT TO TRIM THESE TABS OFF WHEN REMOVING A1 AND A2 FROM THE SPRUES

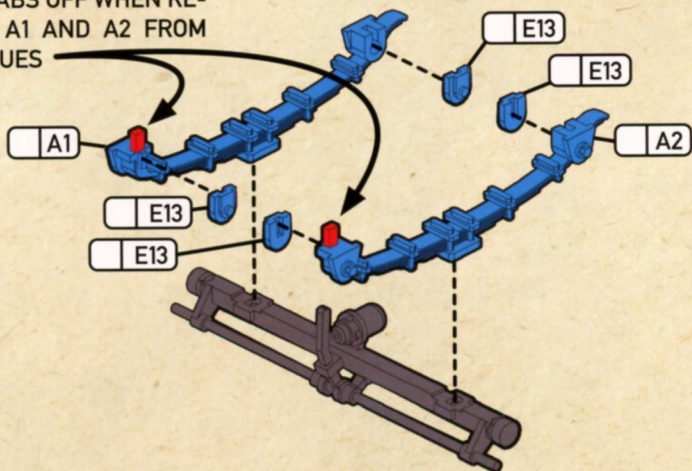

2.3

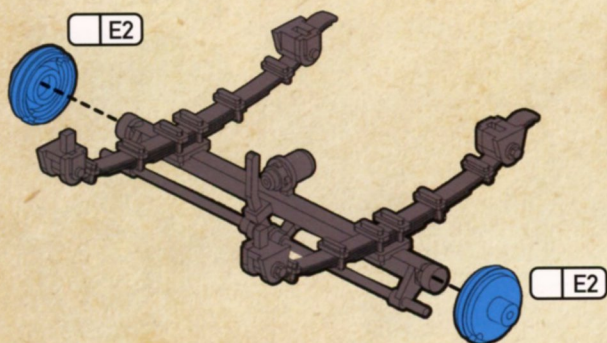

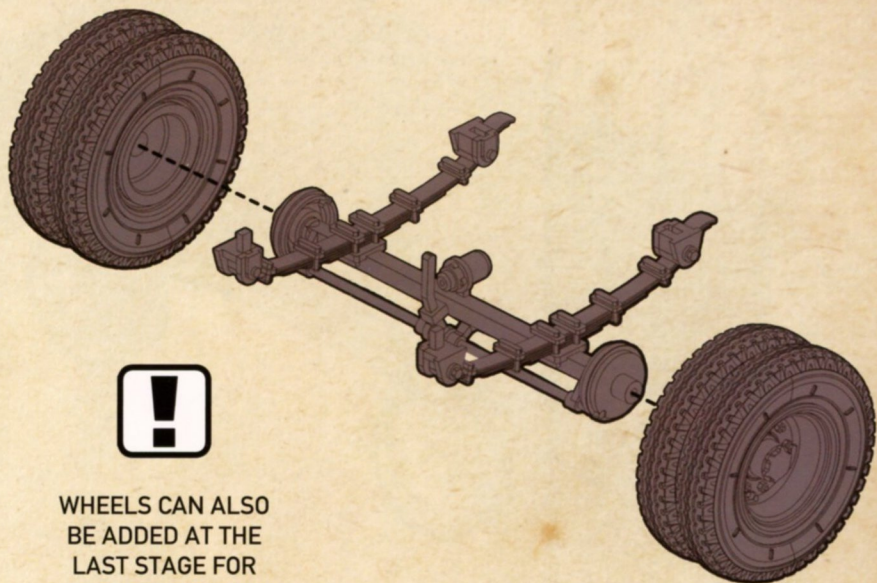

WHEELS CAN ALSO
BE ADDED AT THE
LAST STAGE FOR
EASIER PAINTING
AND ALIGNMENT

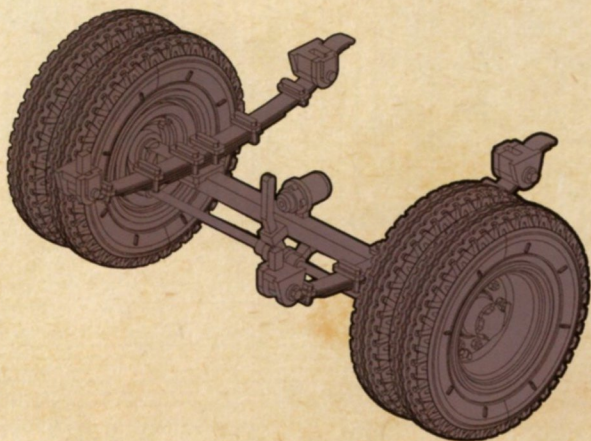

SECTION 3: CARGO BED

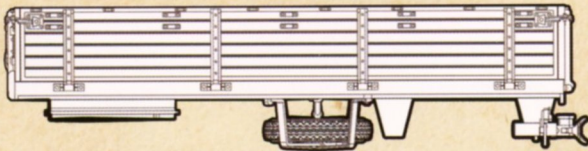
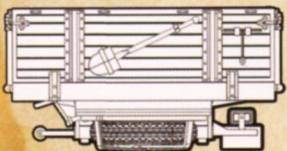
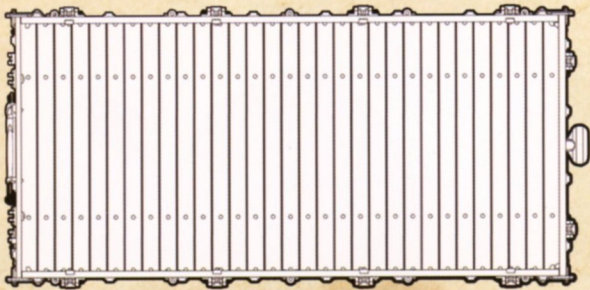
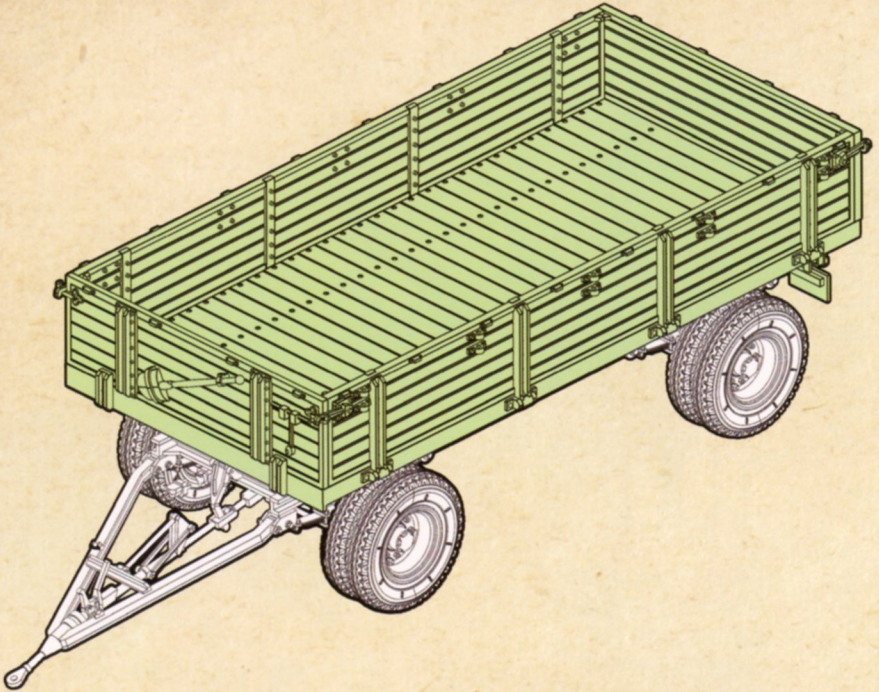

3.1

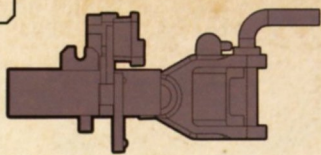

"TYPE 1"



OPTION

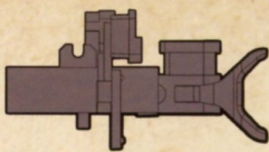

"TYPE 2"

A40



A8



A39

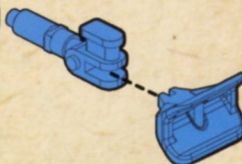

A9



3.2

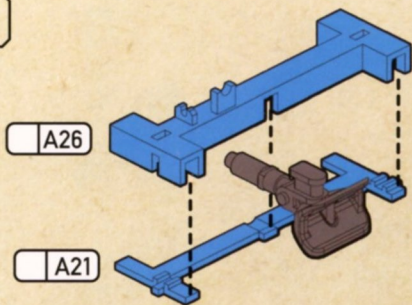

A26

A21

USE PART E12 WHEN
ADDING WIRING DETAILS
IF TRAILER IS TOWING
ANOTHER VEHICLE



E12

A37

E11

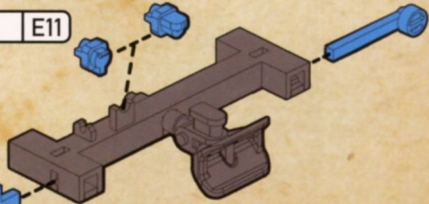

3.3

A36

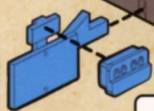

A23



3.4

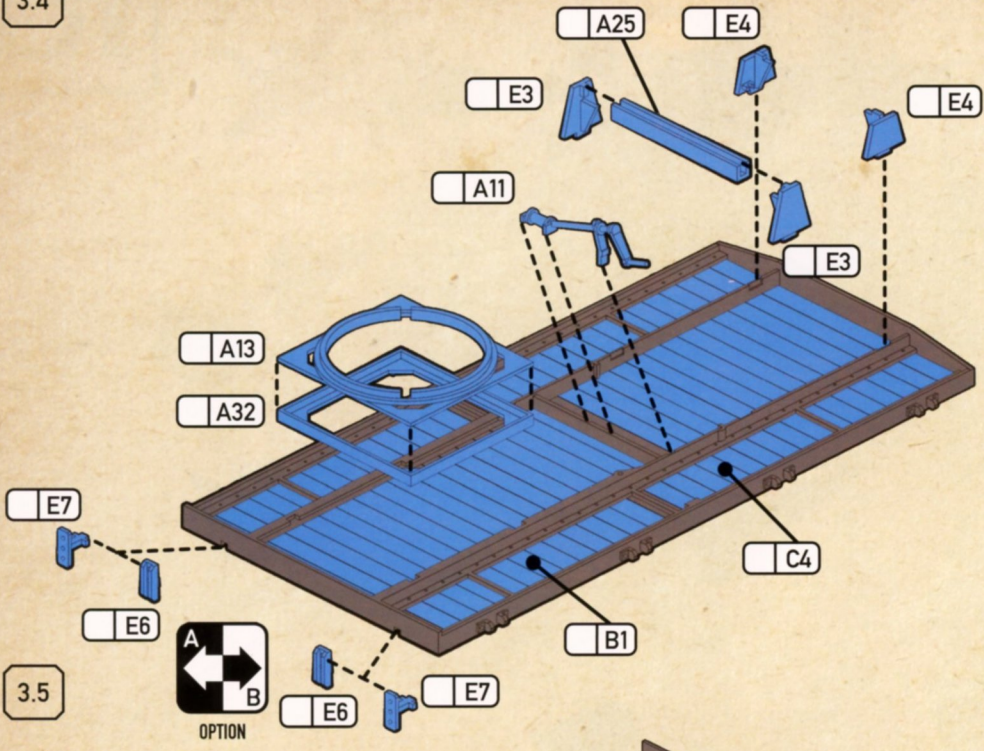

3.5

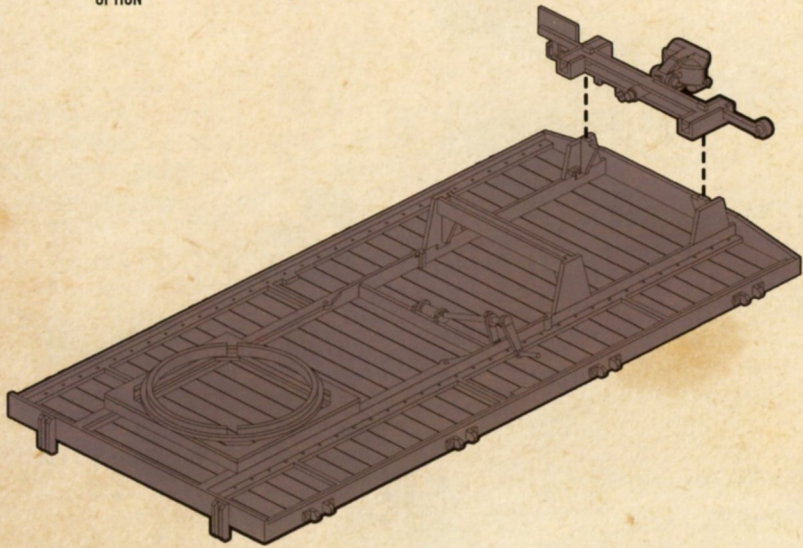

3.6

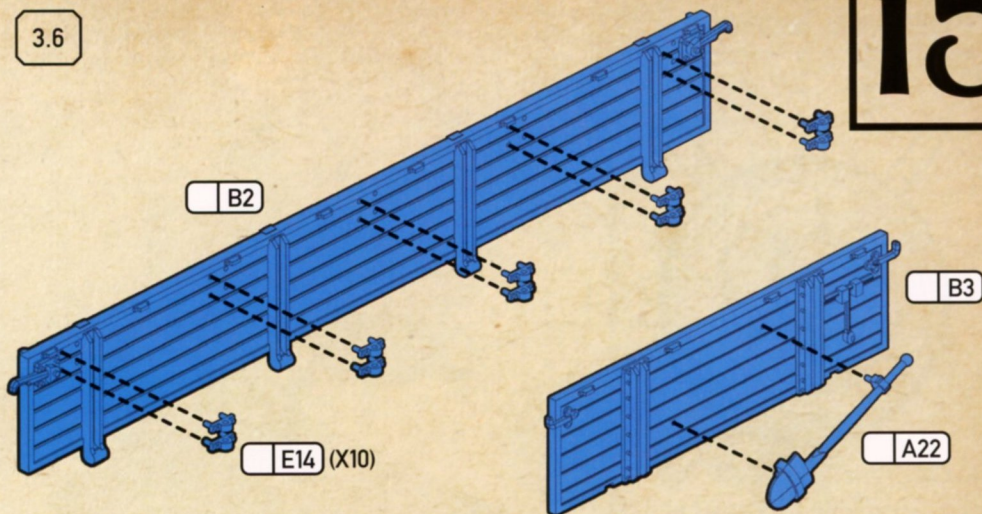

3.7

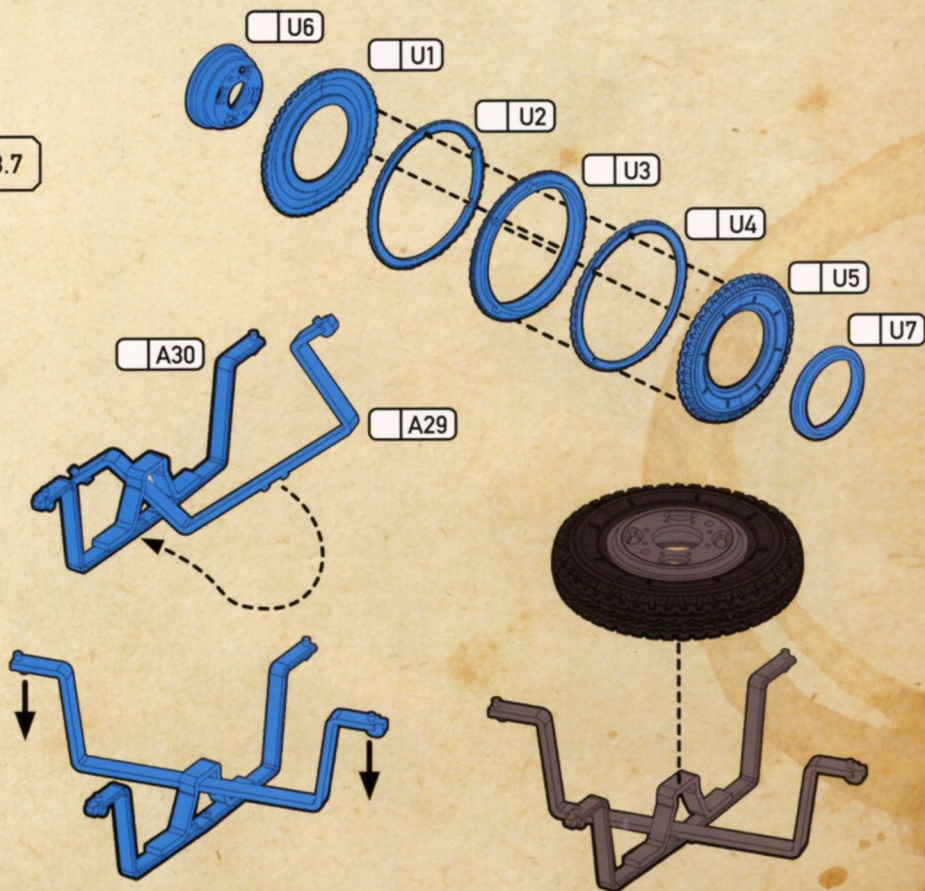

STEP 4: FINAL ASSEMBLY



4.1

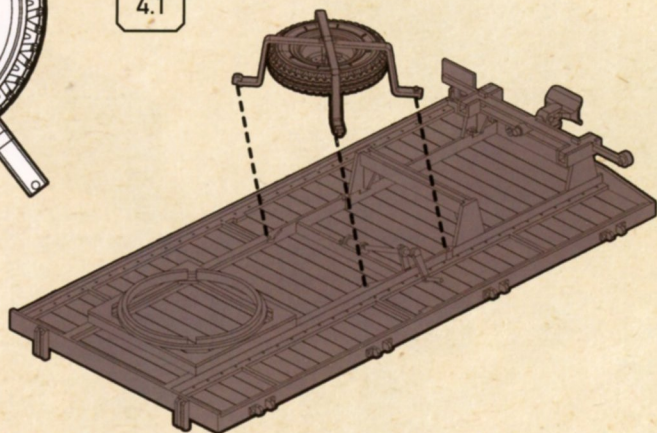

4.2

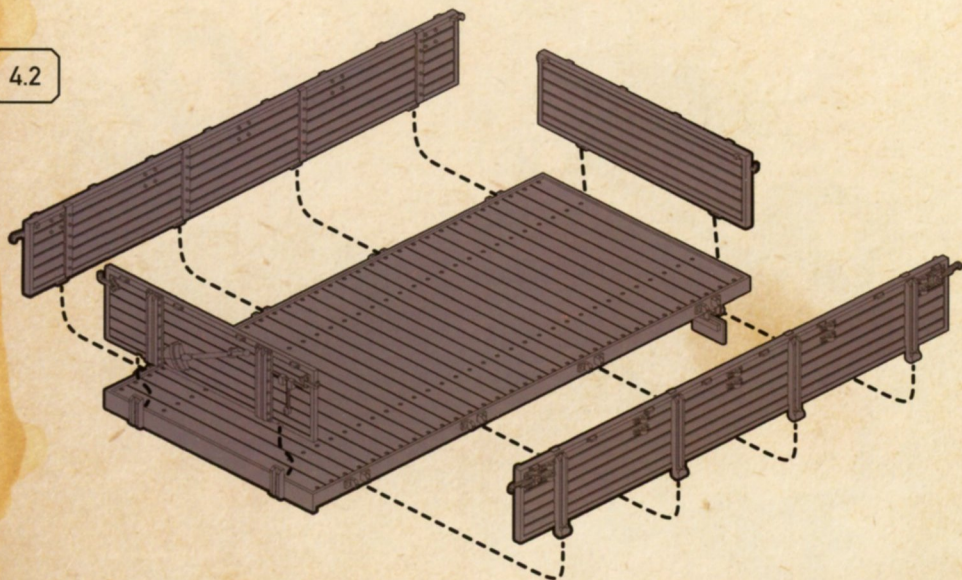

4.3

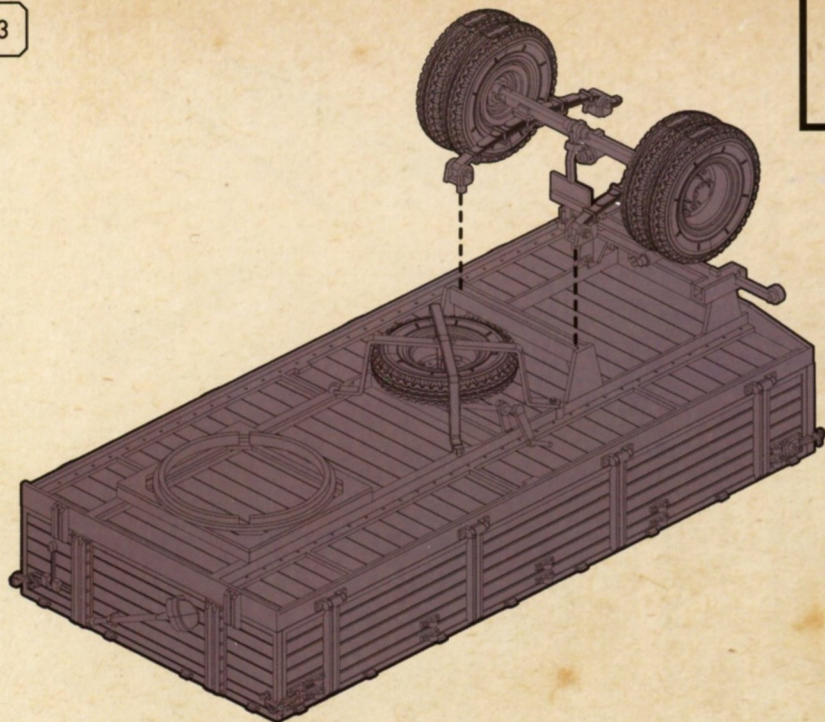

4.4

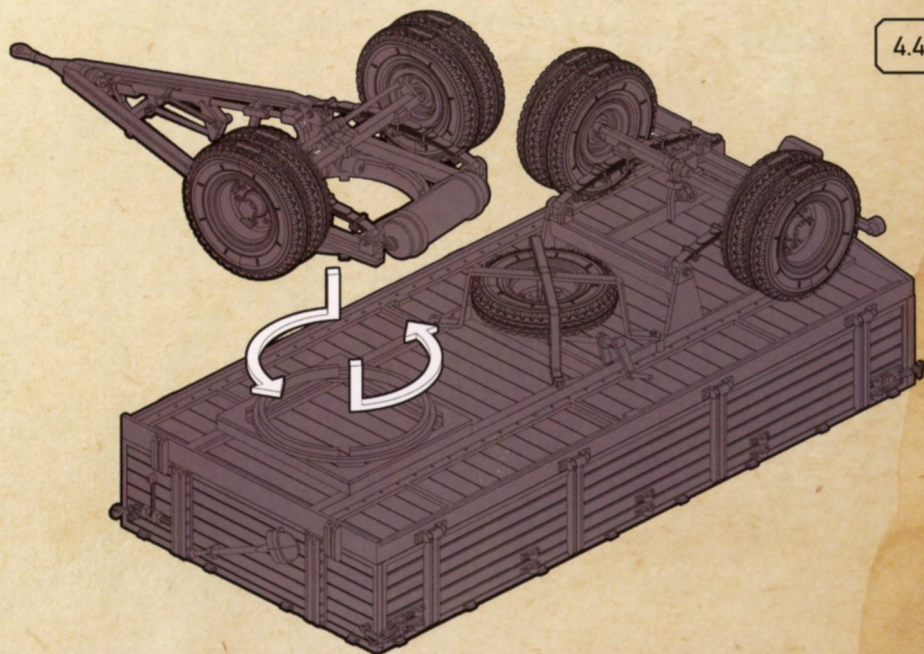

4.5

USE THE PROVIDED JIG TO
BEND THE HOOPS

x 5

REPEAT

Brass rod

← 94mm

← 90mm

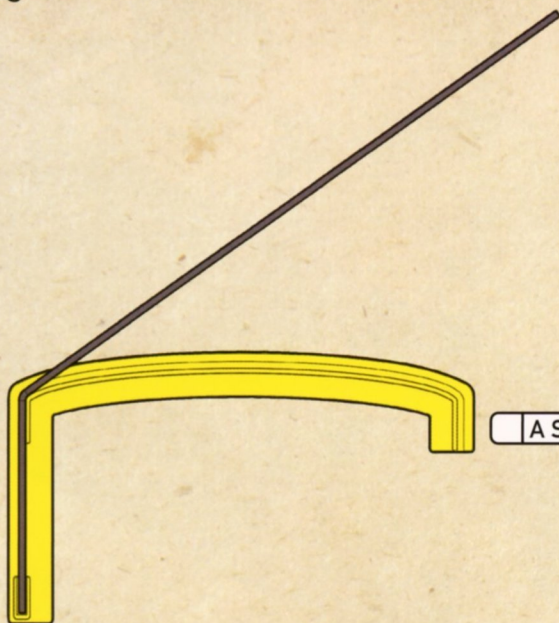

← 32mm

← 28mm

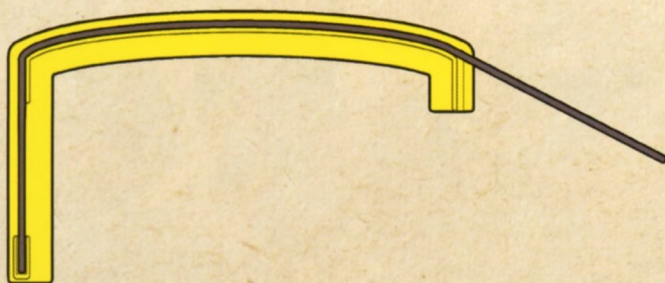

← 0mm



4.6



CAUTION

.8MM DRILL

HALF WAY
THROUGH
LOWER
BRACKET!

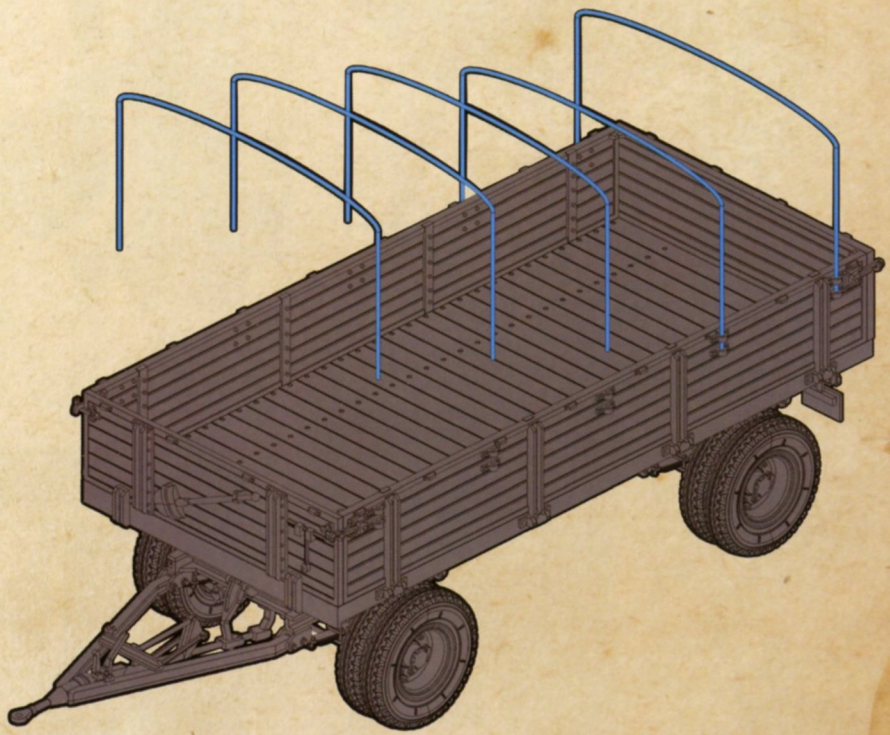
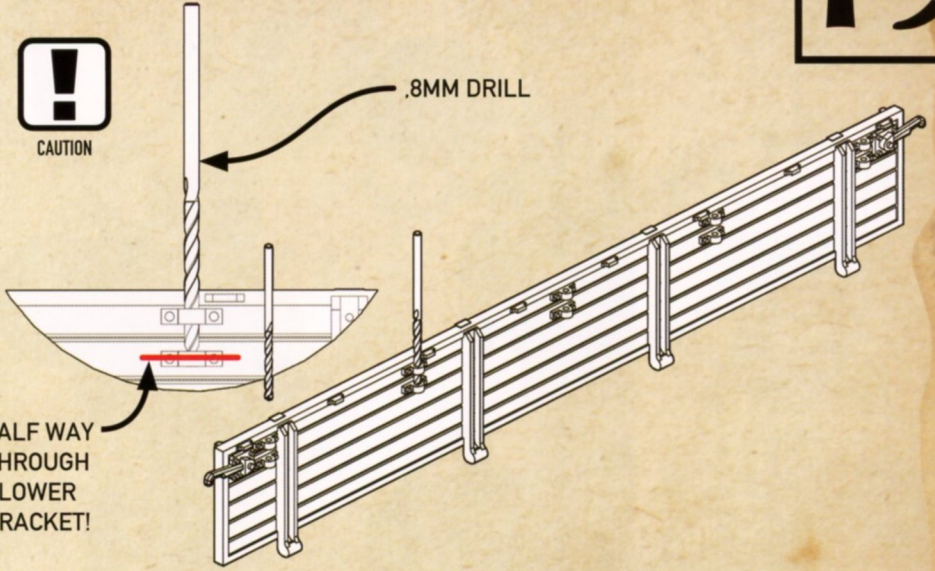

	COLOR	RAL	Tamiya	Mr Hobby H-Series	AMMO of MIG	Vallejo	Humbrol	Mission Models
A	Black	9005	XF1	H401	0032	71.057	33	MMP-047
B	Rubber		XF85	C137 / H77	0033	71.315	/	MMP-040
C	Dunkelgrau	7021	XF63	H401	0008	71.056	67	MMP-014
D	Dunkelgelb	7028	XF60	H403	0011	71.025	83	MMP-011
E	Rotbraun	8012	XF9	C43 / H47	0014	71.271	100	MMP-015
F	Olivgrün	6003	XF58	H405	0002	71.092	117	MMP-009

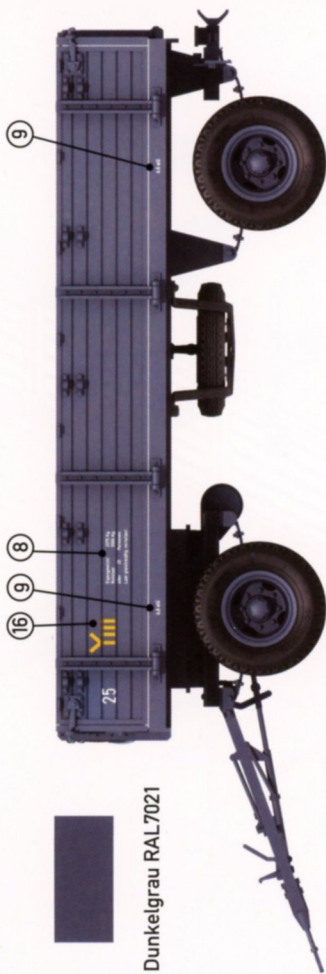

Dunkelgrau RAL 7021

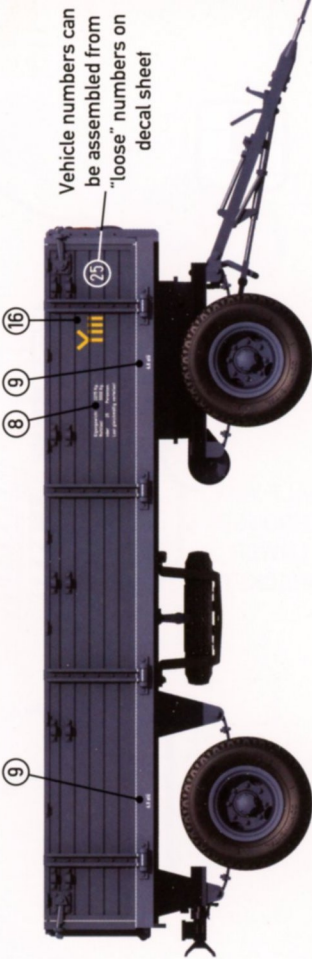
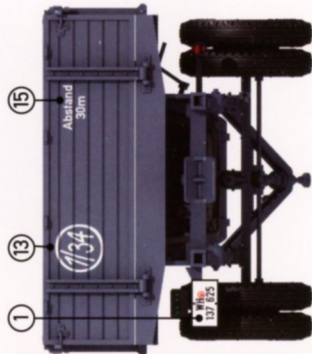

Vehicle numbers can be assembled from "loose" numbers on decal sheet

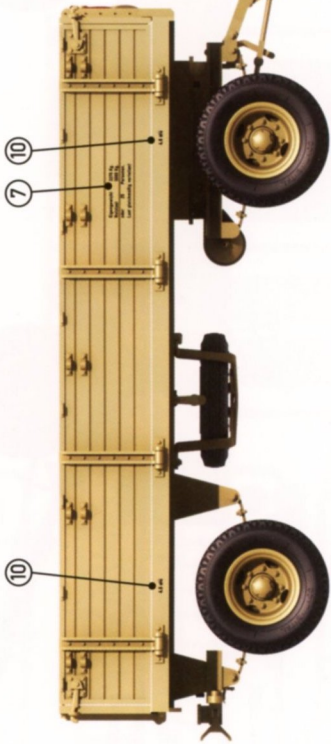
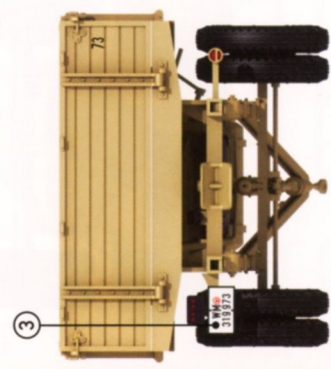
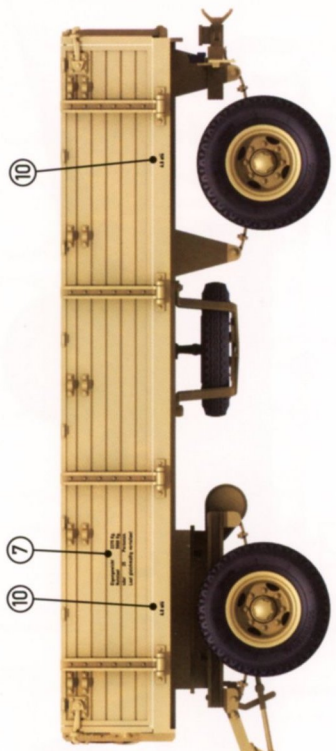
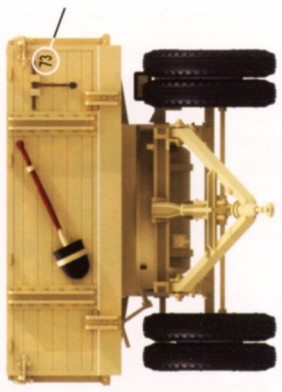

Dunkelgelb RAL 7028
Vehicle numbers can
be assembled from
"loose" numbers on
decal sheet



Dunkelgelb RAL7028

OliveGrün RAL6003

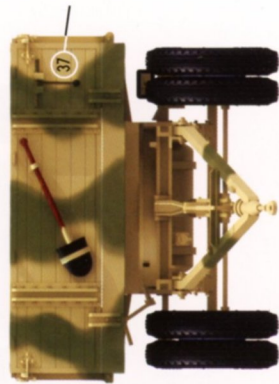

Vehicle numbers can be assembled from "loose" numbers on decal sheet

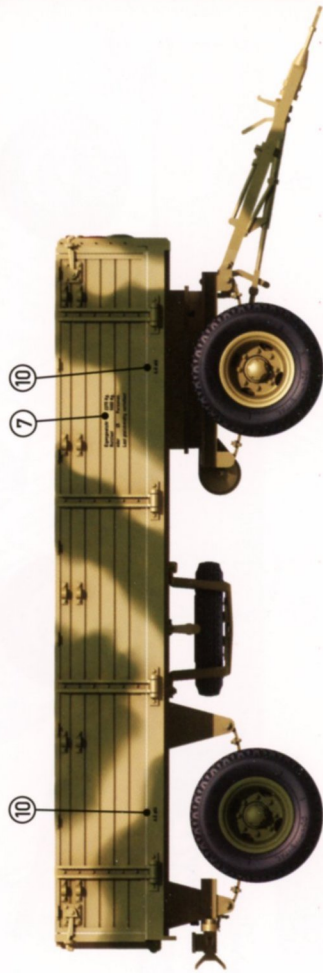

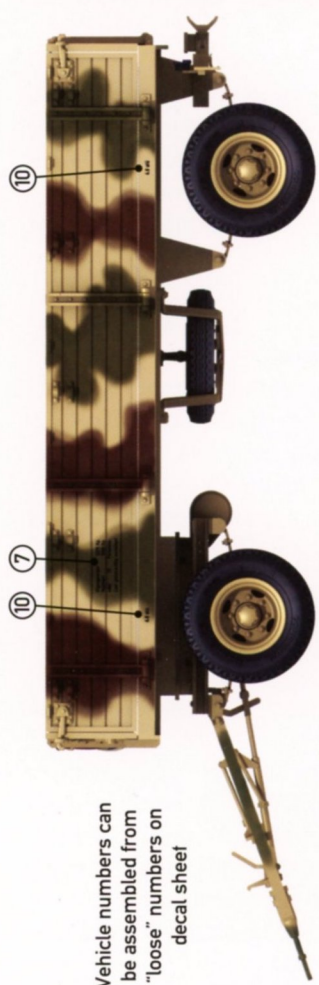

Vehicle numbers can be assembled from "loose" numbers on decal sheet

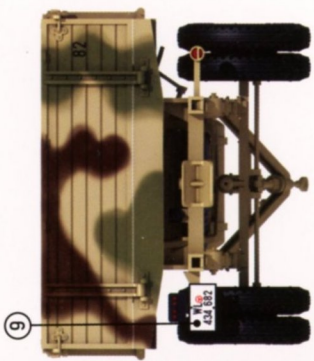
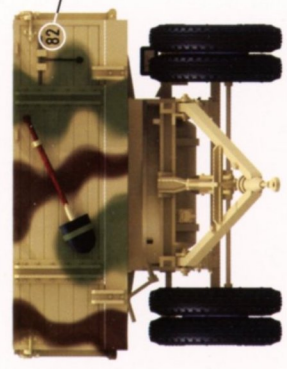
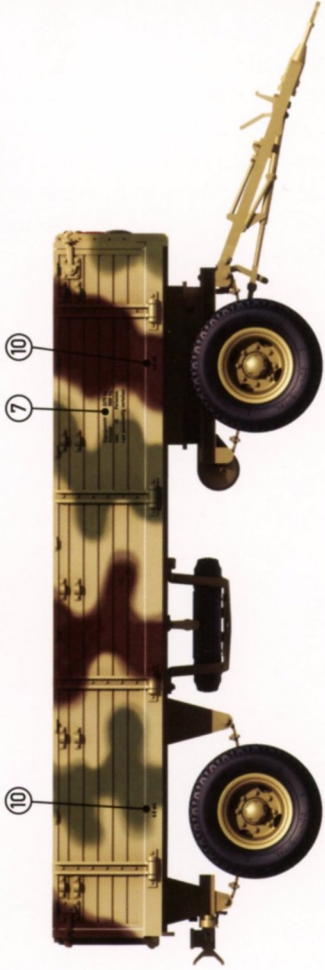

- Dunkegelb RAL7028
- OliveGrün RAL6003
- Schokoladenbraun RAL8017





Harald Bauske ~ CEO

As the owner and managing director of Modellbau König GmbH & Co KG, Harald assembled a team of creative professionals and provided the budgets to pursue one of his dreams: releasing a plastic model kit under his own brand. Now, in late 2018, his dream has come true. Back in 1999, when he made the first steps with his company, he did not imagine that this dream would ever become a reality.



Sebastian Debold ~ Master model maker

Being a former artist/sculptor and an enthusiastic modeler for many years, Sebastian started his own model brand Bolddivision in 2017 and distributes high quality resin kits.

Having the chance to collaborate with Modellbau König to create a plastic kit of one of his models was a great opportunity and a very interesting project.

You can visit him at www.bolddivision.de



Pete Hamann ~ 3D designer, CAD modeler, Instruction manual design

Born and raised in California, Pete worked on his design chops as an aerospace designer in Seattle, Washington before packing up and relocating to Spain. He developed a deep interest in flying machines while growing up next to military air bases in Southern California. After spending a few years as a machinist, making other people's designs a reality, he obtained a bachelor of arts degree in industrial design.

Pete can be reached at Peterjhamann@gmail.com

A DAS WERK & Bold Division production
2019

Modellbaukönig GmbH & Co. KG
Nordenhamer Str. 177
27751 Delmenhorst
Deutschland