

The Junkers Ju 87 or Stuka (from Sturzkampfflugzeug, "dive bomber") was a German dive bomber and ground-attack aircraft. Designed by Hermann Pohlmann, it first flew in 1935. The Ju 87 made its combat debut in 1937 with the Luftwaffe's Condor Legion during the Spanish Civil War and served the Axis forces in World War II. The aircraft was easily recognisable by its inverted gull wings and fixed spatted undercarriage. Upon the leading edges of its faired main gear legs were mounted the Jericho-Trompete (Jericho trumpet) wailing sirens, becoming the propaganda symbol of German air power and the so-called blitzkrieg victories of 1939–1942. The Stuka's design included several innovations, including automatic pull-up dive brakes under both wings to ensure that the aircraft recovered from its attack dive even if the pilot blacked out from the high g-forces.

The Stuka operated with considerable success in close air support and anti-shipping at the outbreak of World War II. It led air assaults in the invasion of Poland in September 1939. Stukas were critical to the rapid conquest of Norway, the Netherlands, Belgium and France in 1940. Sturdy, accurate, and very effective against ground targets, the Stuka was, like many other dive bombers of the period, vulnerable to fighter aircraft. During the Battle of Britain its lack of manoeuvrability, speed and defensive armament meant that it required a heavy fighter escort to operate effectively. After the Battle of Britain the Stuka was used in the Balkans Campaign, the African and Mediterranean theatres and the early stages of the Eastern Front where it was used for general ground support, as an effective specialised anti-tank aircraft and in an anti-shipping role. Once the Luftwaffe lost air superiority, the Stuka became an easy target for enemy fighter aircraft on all fronts. It was produced until 1944, and remained in service until the end of the war. An estimated 6,500 Ju 87s of all versions were built between 1936 and August 1944.

**Painting Mask Set**

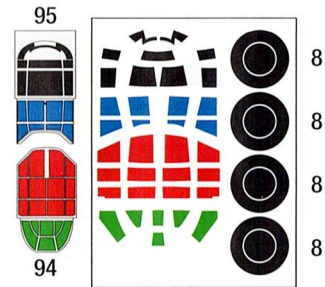

Ju 87 G-2, 10.(Pz)/SG 3, Winter 1944/45

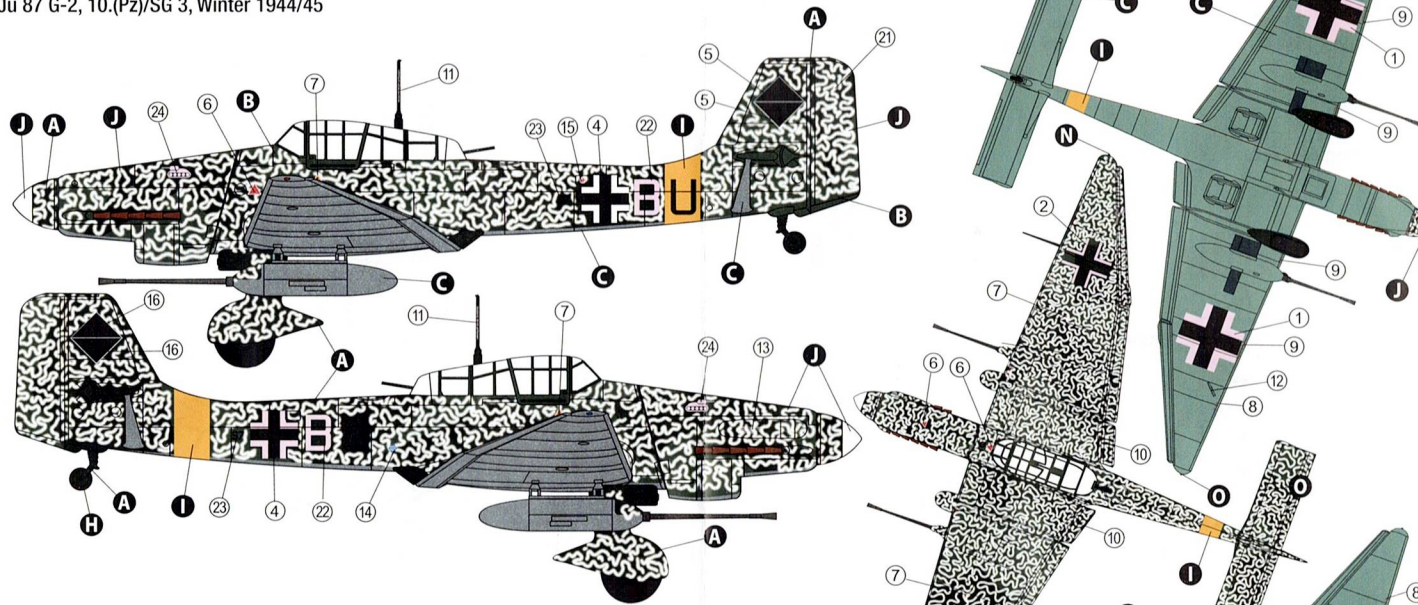

Ju 87 G-2, W.Nr 494193, Stab/SG 2, ObstLT. Hans-Ulrich Rudel, Winter 1944/45

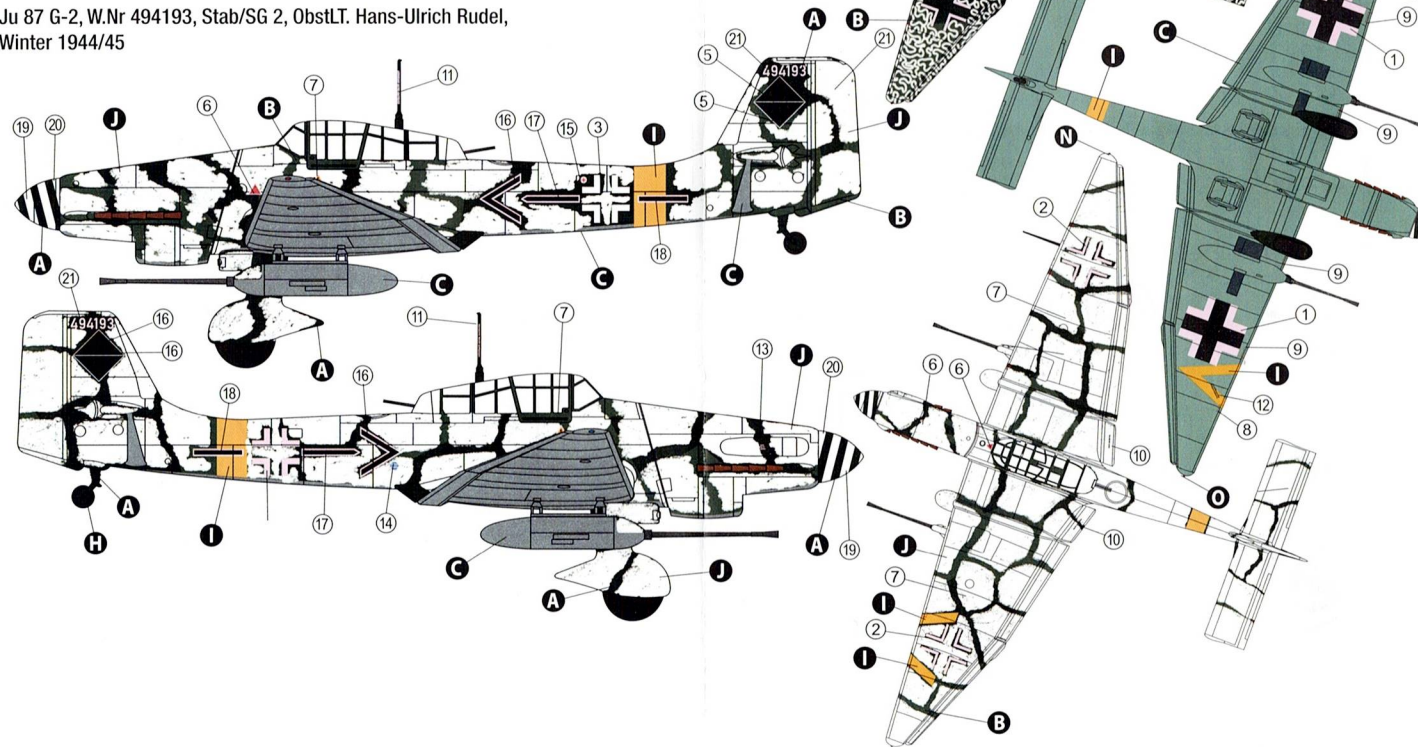

Color Chart	Mr. COLOR	TAMIYA	HATAKA	AMMO	AK
RLM 70 Black Green	<b>A</b> 18	XF-27	015	232	RC274
RLM 71 Dark Green	<b>B</b> 17	XF-62+XF-49	017	233	RC275
RLM 65 Light Blue	<b>C</b> 115	XF-23+XF-2	029	231	RC272
RLM 80 Olive Green	<b>D</b> 120	XF-58	053	248	RC284
RLM 79 Sand Yellow	<b>E</b> 119	XF-59	014	222	RC282
RLM 78 Light Blue	<b>F</b> 118	XF-23	314	247	RC280
RLM 66 Black Gray	<b>G</b> 116	XF-24	040	218	RC339
Flat Black	<b>H</b> 33	XF-1	100	046	RC001
RLM 04 Flat Yellow	<b>I</b> 113	XF-3	066	048	RC267
RLM 21 White	<b>J</b> 62	XF-2	101	047	RC004
RLM 24 Dark Blue	<b>K</b> 322	XF-8	274	229	RC327
Silver	<b>L</b> 8	X-11	003	195	AK478
Rust	<b>M</b> 61	XF-79	132	040	AK485
Clear Blue	<b>N</b> 50	X-23	CC01	098	RC504
Clear Red	<b>O</b> 47	X-27	CC02	093	RC503

# ASSEMBLY INSTRUCTION

Istruzioni di Assemblaggio

Bauanleitung

Instrukcja Montaży

Instructions de Montage

Montážní Instrukce

Instrucciones de Montaje



OPTION  
NACH BELIEBEN  
DO WYBORU  
VOLBA

FACULTATIF  
HACER AQUJERO  
FACOLTATIVO



APPLY DECAL  
HIEAR ABZIEHBILD  
KALKOMANIA  
POUŽIJTE OBTISK

APPLICARE DECALCOMANIE  
PONER CALCOMANIA  
APPLIQUER DECALCOMANIE



OPEN HOLE  
OFFNEN  
WYKONAĆ OTWÓR  
VYVRTAT OTVOR

FORO APERTO  
HACER AQUJERO  
FAIRE UN TROU



REMOVE  
ENTFERNEN  
WYCIĄĆ  
ODSTRANIT

RETIRER  
CORTAR  
SEPARARE

## 1 Cockpit Assembly

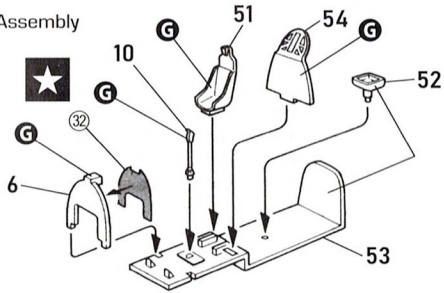

## 2 Fuselage Assembly

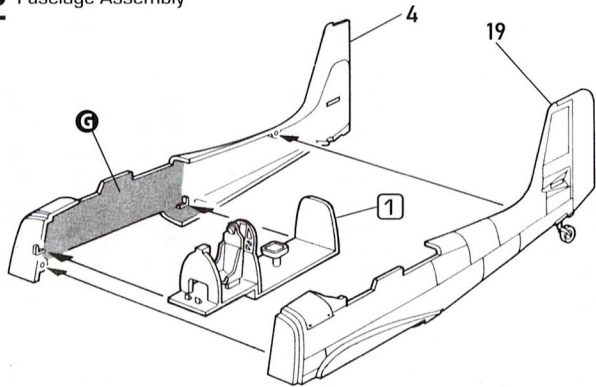

## 3 Engine Assembly

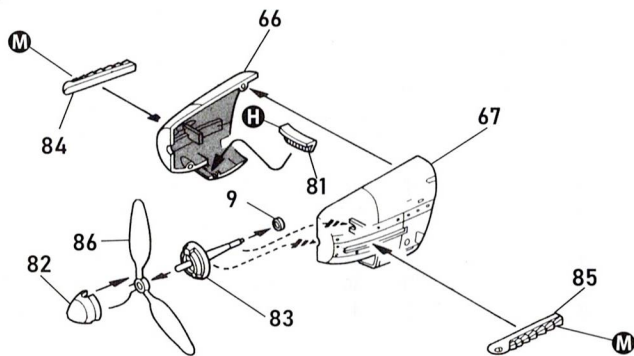

## 4 Main Wing Assembly

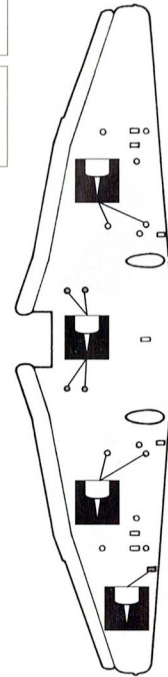
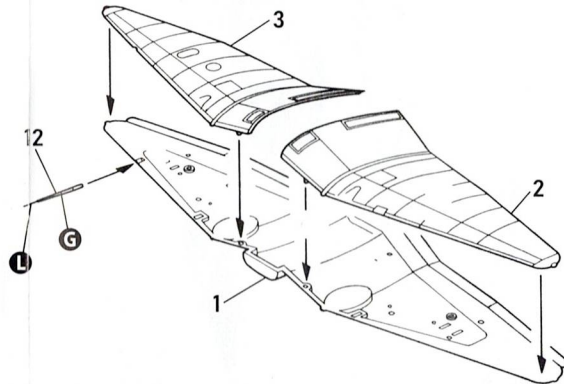

## 5 Main Wing, Horizontal Stabilizer & Engine Installation

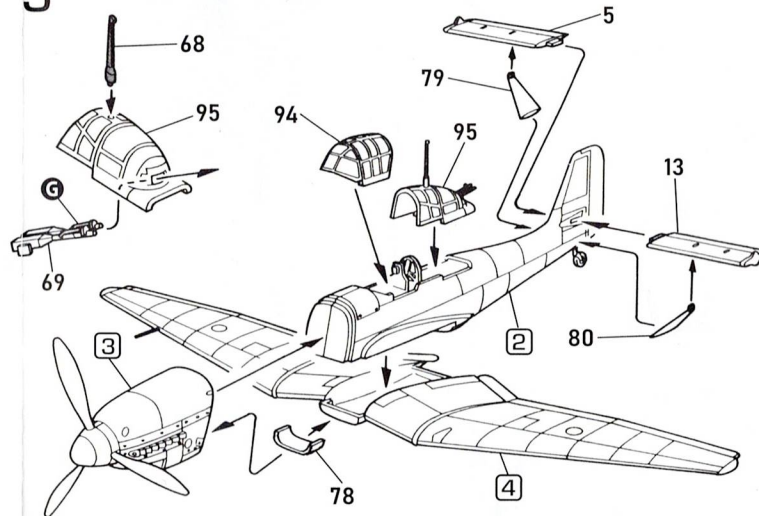

## 6 Various Parts Installation

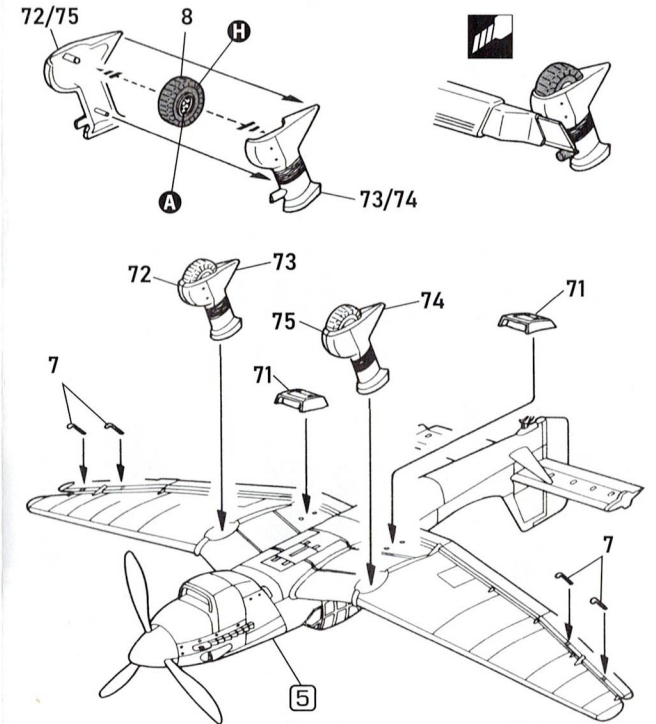

## 7 Armament Installation

