

CONVAIR 340 / C-131

MACH 2
17 rue emile combes
78800 Houilles - FRANCE
tél : 01 39 57 77 03
dpalix@9online.fr
www.mach2.fr

BEWARE : Decals are laser printing and are very thin and fragile . We recommand to be very carefull or to spay a varnish coat in order to avoid any cracking

ATTENTION : Les décalques sont imprimés laser . Ils sont donc très fins et de fait très fragiles. Ainsi nous vous recommandons d'etre très délicat ou de vaporiser une couche de vernis afin d'éviter toute déchirure

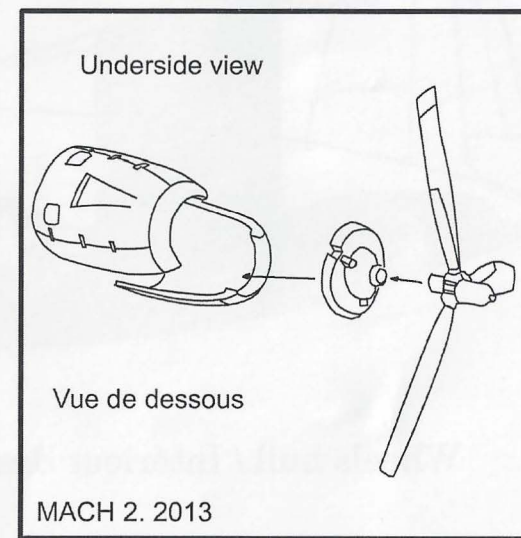
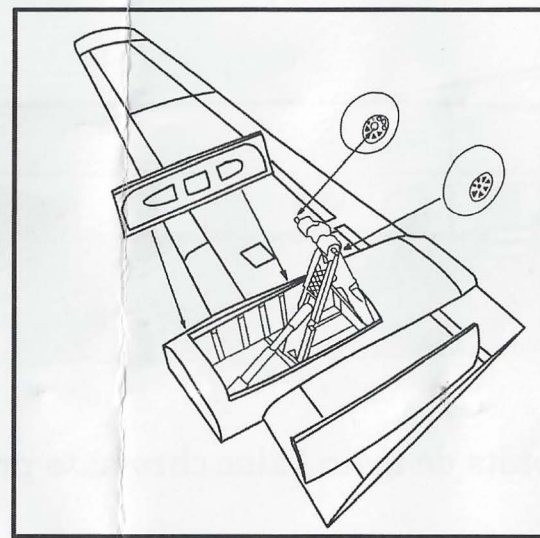
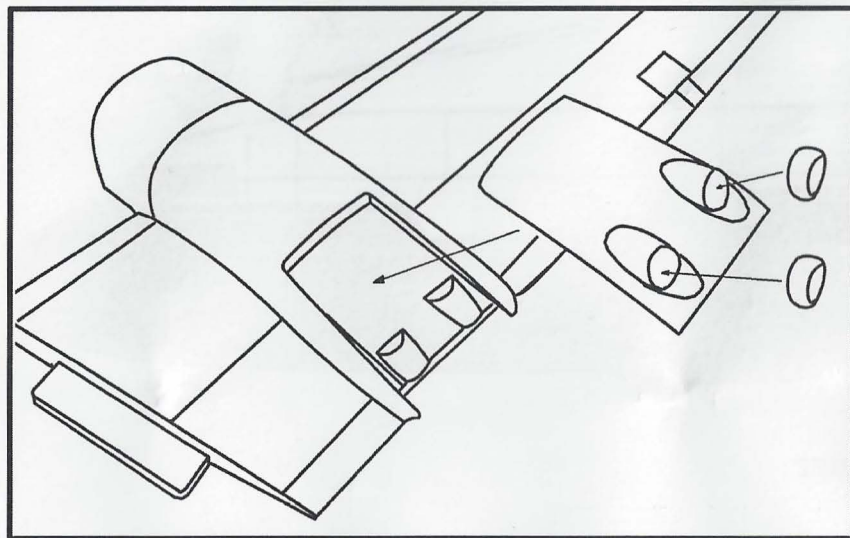
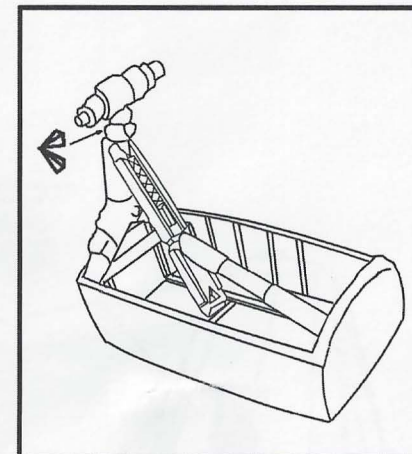
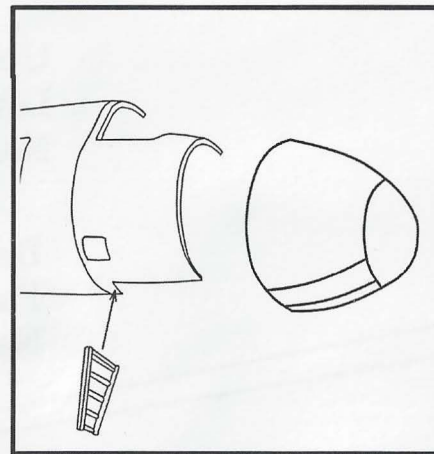
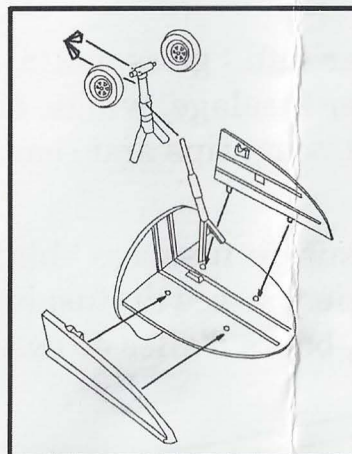
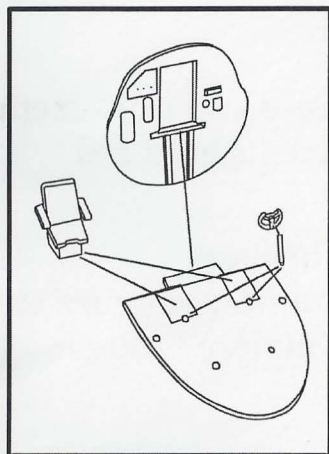
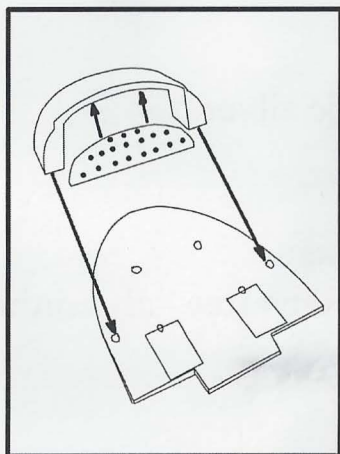

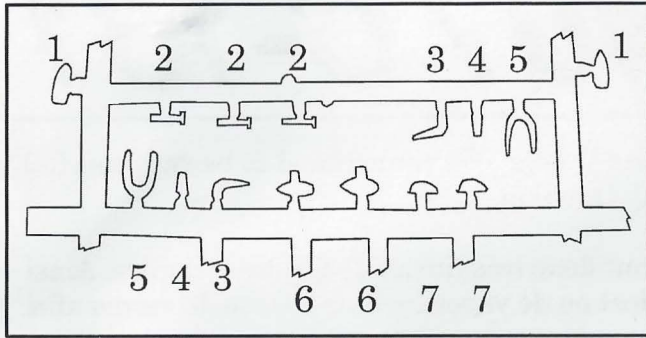

All aerial and air scope are supplied in two exemplaries
 For this version use only parts indicated bellow :

Toutes les antennes et prises d'air sont fournies en double exemplaires. Pour cette version, vous ne devez utiliser que les pièces indiquées ci dessous :

Upper hull : gloss white

Lower fuselage, wings, engines and tail : metallic silver

Nose, wing tips and rear stipe : signal red

Dessus du fuselage : blanc brillant

Parties basses du fuselage, ailes , moteurs et plans fixe : aluminium

Nez, bouts d'ailes et bande arrière : rouge

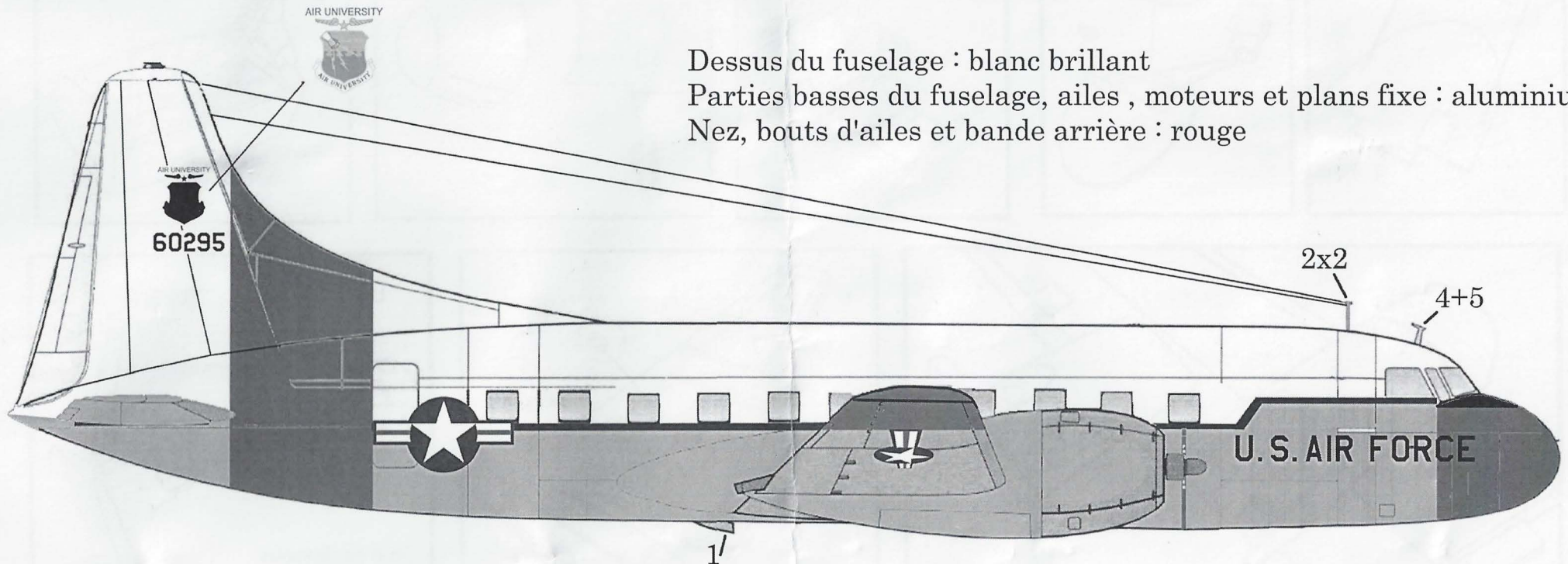

Wheels hull / Intérieur des puits de train : zinc chromate primer

U.S. AIR FORCE

U.S. AIR FORCE

USAF 60295
USAF 60295

USAF

AIR UNIVERSITY



AIR UNIVERSITY

