

## Spitfire F/FR Mk XIVe Conversion

1/32 Conversion Set for Tamiya Spitfire MkXVIe "Low Back"

Laminar Flow Design  
 Email : [info@laminarflowdesign.com](mailto:info@laminarflowdesign.com)  
[www.laminarflowdesign.com](http://www.laminarflowdesign.com)



- Working with 3D printed parts.
  - Removal of the supports: Parts are printed into an enclosed cage that protects them in the different stages of production, transport and storage. Please cut the 4 pillars at their base on the corners and clean up the remaining mesh to access the parts. Then you can remove the parts from their support, starting by the most accessible on the sides and working your way to the center. Work support by support, using razor saw or new scalpel blade.  
 Avoid snapping the part off its supports as it could damage the part in the process.
  - Outer fuselage surfaces (ie: Sides of the cowling) might need Surfacer and sanding work for optimal result. Please try to avoid filling small rivets in the operation.
  - Don't "force fit" parts into assembly. Cured resin is very hard but will break under pressure.
  - For accurate fitting, prefer trimming and sanding the plastic parts rather than resin. Plastic is easier to form and shape. But ultimately the choice is up to the builder.
  - Washing agent residues can remain on some surfaces, fine grid sand to get rid of them
- Preparatory work
  - Fuselage:
    - Fuselage cuts: Please refer to the image for the tail post and engine cut out. There is no template provided for these cut as they are quite straightforward and are along the panel lines. Use razor saw for the cut, and finish with scalpel and Flat file.

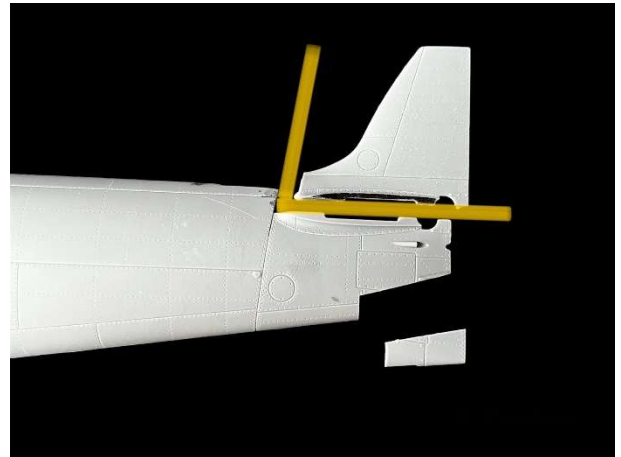
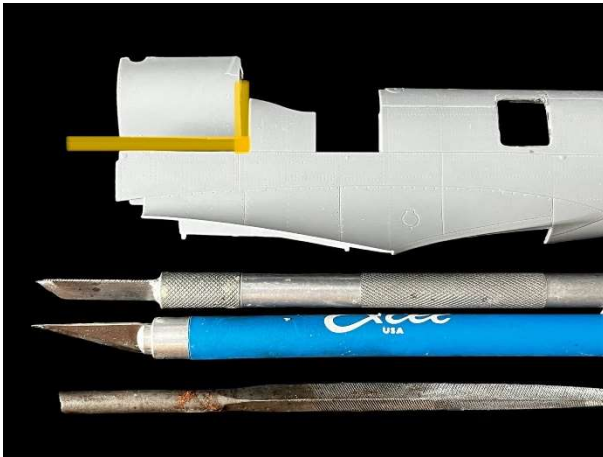

- Griffon Nose: place the windshield base template (located on Mask sheet D5) on a 0.5mm thick plastic sheet and cut a part out of it. Form it to the tank outer curve and CA glue it in the windshield recess on the resin nose. This is to ensure that the windshield part can be glued to the fuselage without CA glue and avoid fogging on the clear part.



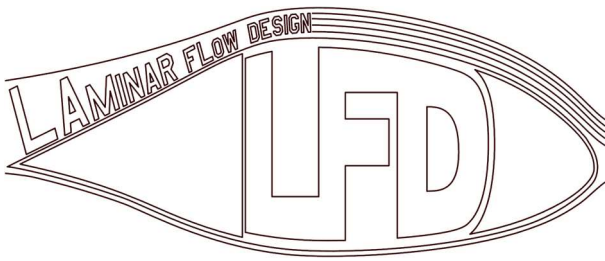

## Spitfire F/FR Mk XIVe Conversion

1/32 Conversion Set for Tamiya Spitfire MkXIVe "Low Back"

Laminar Flow Design  
 Email : [info@laminarflowdesign.com](mailto:info@laminarflowdesign.com)  
[www.laminarflowdesign.com](http://www.laminarflowdesign.com)



- Hatches : Refer on the version you are building. Use the corresponding template to mark the position, once satisfied, attach temporarily the template with tape. Drill multiple holes and finish with scalpel to remove the inner portion. Finish with flat and round files to conform to the template opening. Check the fit of the hatch with your opening regularly, but again, don't force it into, it would break.
  - For FR Spitfire, all 3 hatches need to be installed. Take extra care on the LH front Hatch, the template must be aligned with the sides of the existing hatch that sits higher on the fuselage. Once opened, fill and sand the remnants of the original hatch (Hinge and panel line)
  - For F spitfire, add the rear right fuselage only. The LH Side front Hatch on the Tamiya fuselage needs to be filled and smoothed, prolong existing rivets lines to blend in your work.

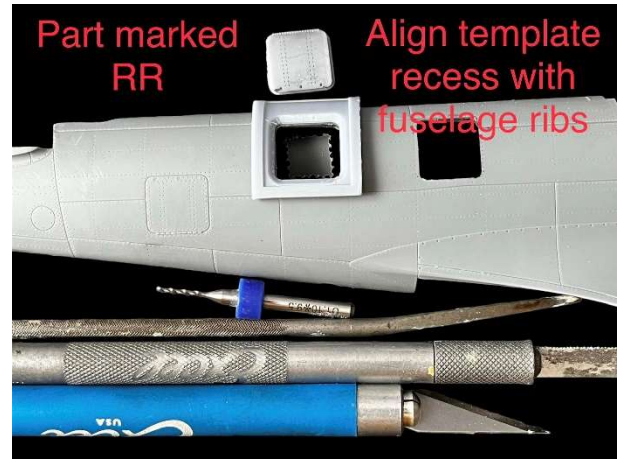
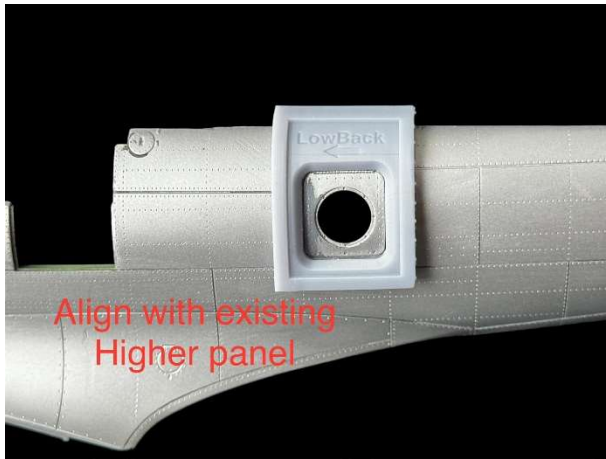

- Retractable Tail Wheel: Start with the LH side template, it slots into the rudder actuator recess on the fuselage. Fix it with tape, then fix the RH side template at the exact same height. Once happy, proceed with razor saw, scalpel and finish with flat file.

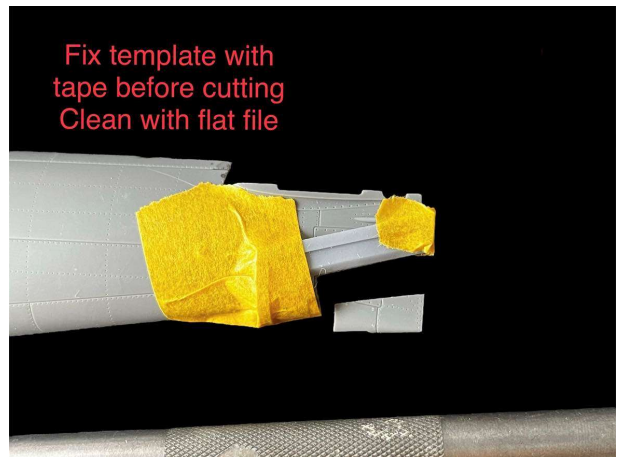

- Tail Post: With the original tail chopped off, all left is to remove material to allow for the strengthening rib on the tail post. Width of the rib is 1mm.

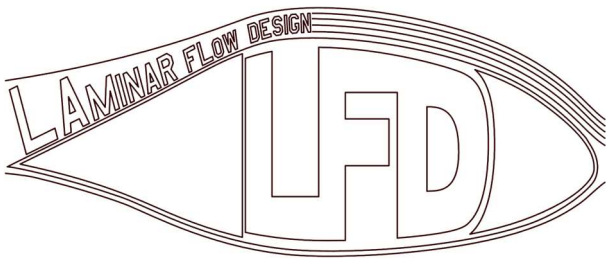

## Spitfire F/FR Mk XIVe Conversion

1/32 Conversion Set for Tamiya Spitfire MkXIVe "Low Back"

Laminar Flow Design  
 Email : [info@laminarflowdesign.com](mailto:info@laminarflowdesign.com)  
[www.laminarflowdesign.com](http://www.laminarflowdesign.com)



- Fuselage ID light: (Optional, check your subject references). Mark a point at 16.5mm from the wing joint, right in the axis. Then drill a 5.1mm diameter hole from that point, use round file to bore at the right diameter.



### ○ Wings:

- Fuel Tanks: Align templates with the inner circular access hatch. Mark 1<sup>st</sup> with a fine pencil to check, once happy with the location, fix the first template and scribe the outline with your preferred engraving tool. Fix the 2<sup>nd</sup> template inside the first, then proceed to engrave the filling port. Sand clean and fix with a small drop of extra thin.

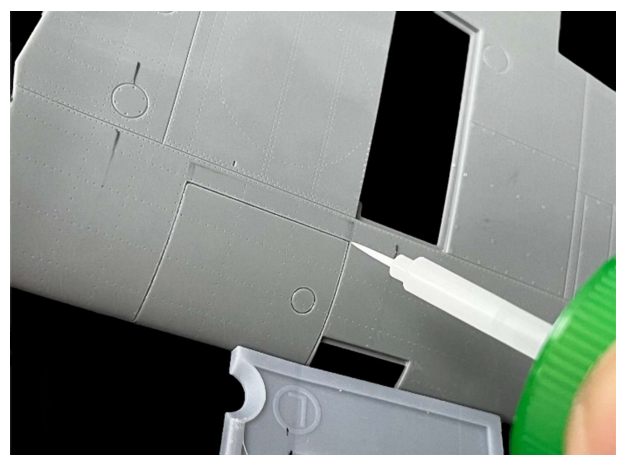
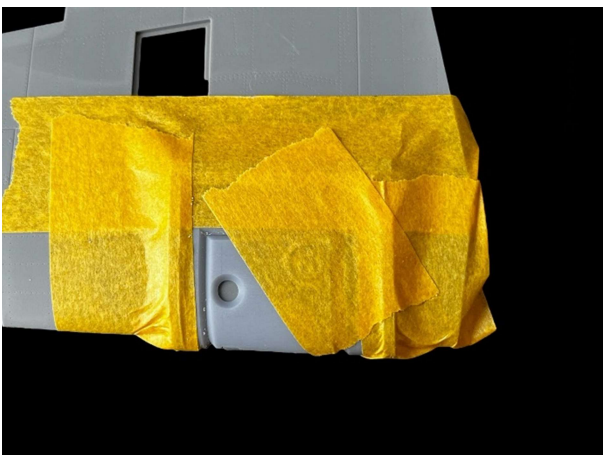
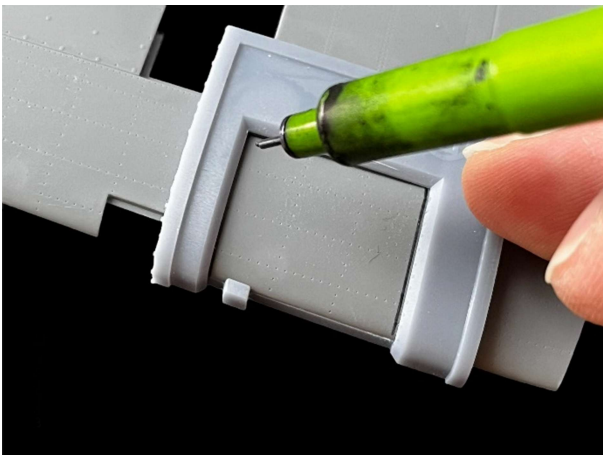

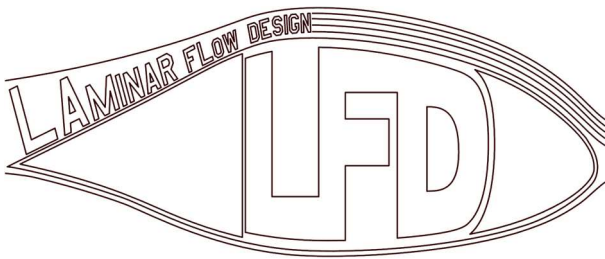

## Spitfire F/FR Mk XIVE Conversion

1/32 Conversion Set for Tamiya Spitfire MkXVIe "Low Back"

Laminar Flow Design  
 Email : [info@laminarflowdesign.com](mailto:info@laminarflowdesign.com)  
[www.laminarflowdesign.com](http://www.laminarflowdesign.com)



Add rows of fasteners and rivets per the last picture (courtesy of MkVIII wing)

- Downward ID lights (Optional,

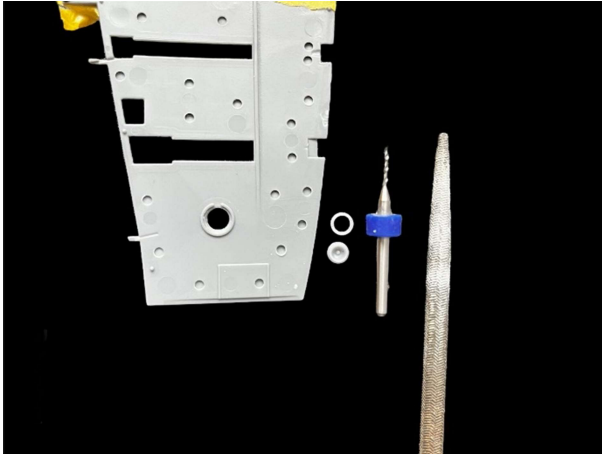

- Ailerons Shortening: Cut Parts B5/B6 at the outer line, keep cut parts to reassemble with the wings, eventually add a plastic strip along the seam to keep the alignment. putty and sand the joints to blend in the wing. See Reference pic.

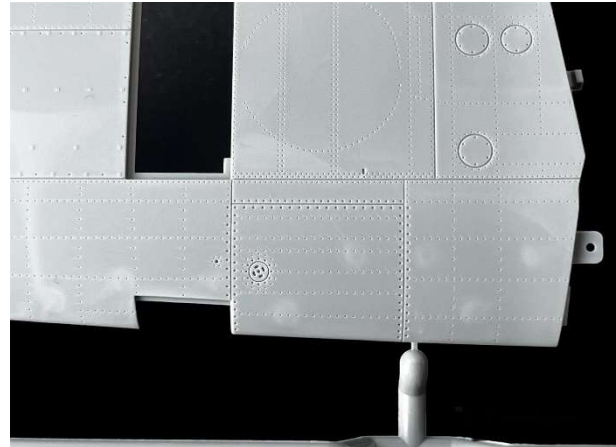

check your subject references): Drill the pre-molded part inside the wing, finish the diameter with round file. Test fit with the assembly.

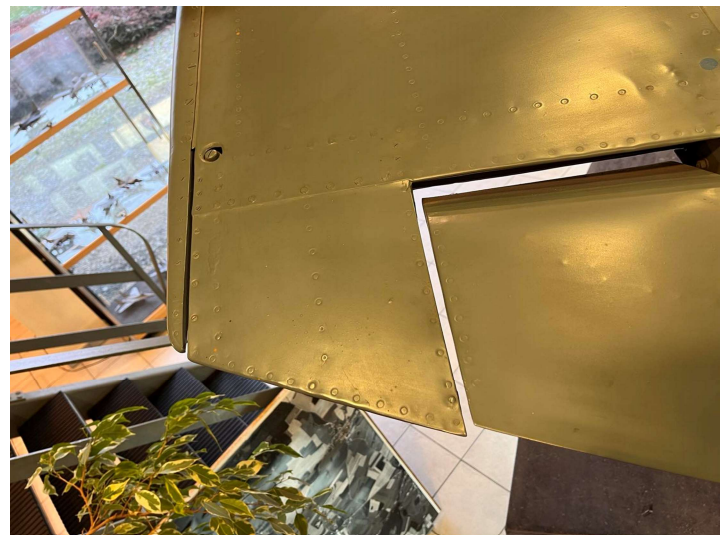

- General Assembly:



○ Fixation of the nose: Proceed on Step 15 on the model assembly but omit part G6 when assembling fuselage (Check Tail post instructions when assembling the fuselage). Slide Part G6 (+G3+Polycaps) into the nose protruding pins, but don't glue it. Place the nose assembly into the assembled fuselage and place part G6 in its side locating holes. Test fit and CA glue the nose to fuselage from under inside. Extra thin could be used to seal G6 into its fuselage locating tabs



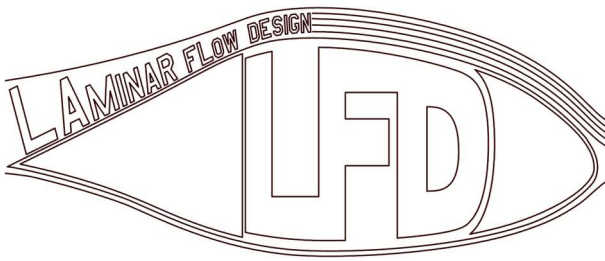

## Spitfire F/FR Mk XIVe Conversion

1/32 Conversion Set for Tamiya Spitfire MkXIVe "Low Back"

Laminar Flow Design  
 Email : [info@laminarflowdesign.com](mailto:info@laminarflowdesign.com)  
[www.laminarflowdesign.com](http://www.laminarflowdesign.com)



Assembly of the nose parts: Use parts from cage 2 and 3. Add the Spinner Counter plate at its base (Not on the below picture). Avoid Gluing the Propeller Axle, it is designed to allow turning the prop. Assemble part AA27 (provided in the box, but normally unused) to the rear of the carb intake.

Choose between Rounded exhausts and Fishtail exhausts.

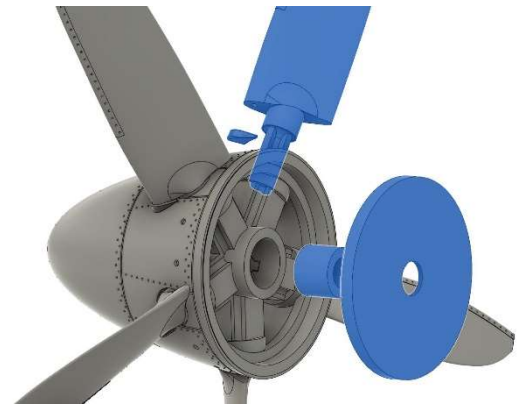
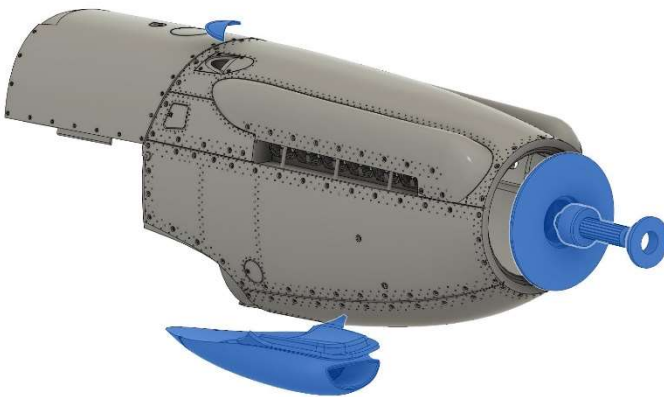

- Radiators  
 Insert front and rear grill, check text ref and orientation. Clean contact parts and between the 2 grills to ensure optimal fitting. Absolutely don't force them into position, again, they would break. Position the vent open or closed at your discretion.

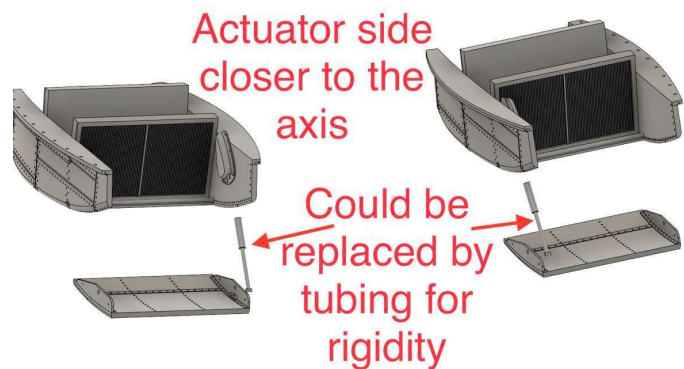
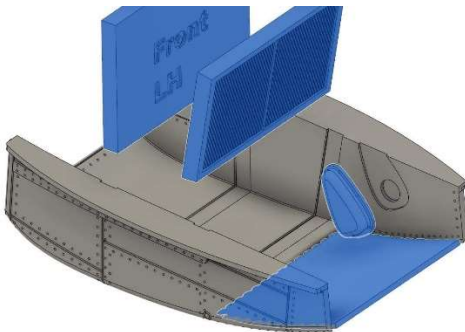

- Tail Post  
 Choose between Std or enlarged rudder (check your references).  
 While special care has been taken to design the most fittable part as possible, the tail post assembly is a tad wider than the stock part, and thus require a few modeling skills: The rear fuselage joint needs a bit of shimming to comply with the

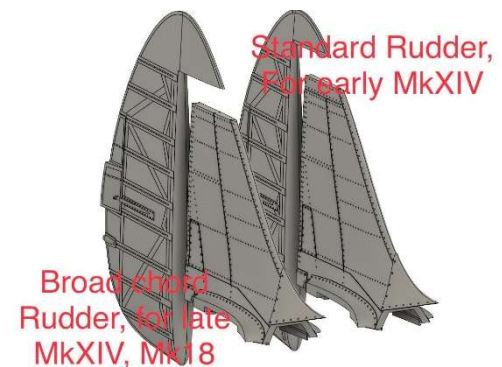

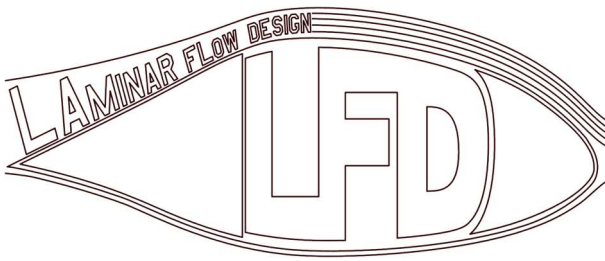

# Spitfire F/FR Mk XIVE Conversion

1/32 Conversion Set for Tamiya Spitfire MkXVIe "Low Back"

Laminar Flow Design  
 Email : [info@laminarflowdesign.com](mailto:info@laminarflowdesign.com)  
[www.laminarflowdesign.com](http://www.laminarflowdesign.com)



global width. When assembling the fuselage, do not glue the fuselage part at the rudder junction (see picture).

Shim accordingly up and down to comply with the tail post and wheel well insert.

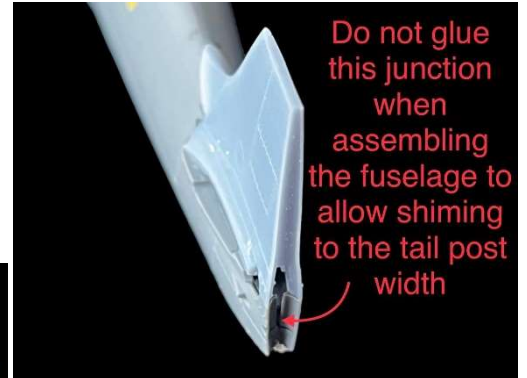

Last step, as the tail is a bit wider, there

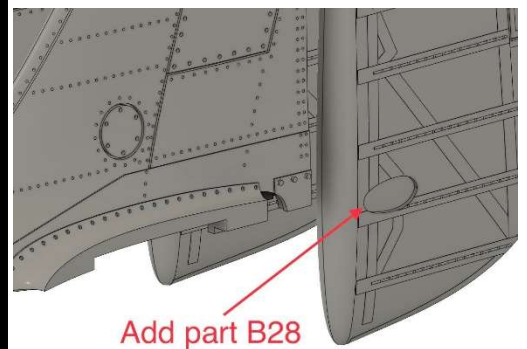
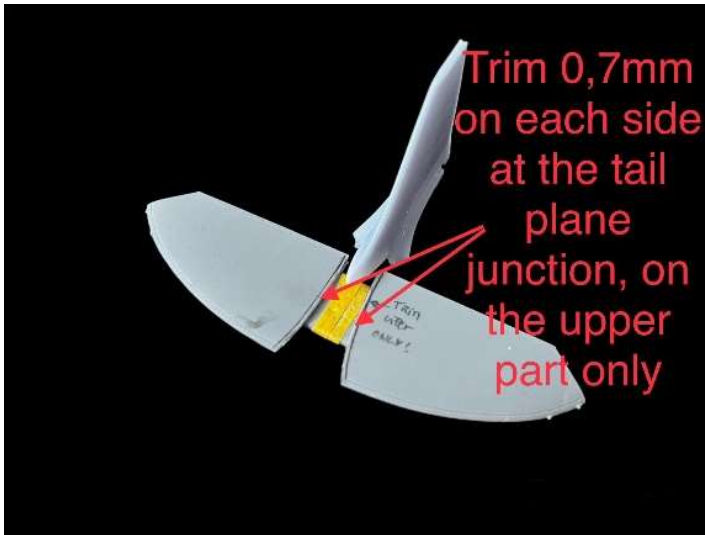

is 0.7mm to remove along the inner junction on the upper part of the horizontal tail plane. Keep the same contour. Best is to mark the line before committing to cut. See picture.

This step ensures there is a minimal gap on the underside of the tailplane.

Prepare the rudder and affix part B28 to it. Wait to have shimmed the fuselage to the tail width, to fix the rudder.

- Retractable Tail wheel



As per picture, insert the well into the fuselage.

Slide the fork into its hole. Use a 0.5mm diameter Rod to complete the wheel assembly with the fork.

Add the door mechanism rod (parts provided or micro tube)

Once assembled, take extra care to not break the doors as they are very fragile.

This assembly could wait the very end of your build.

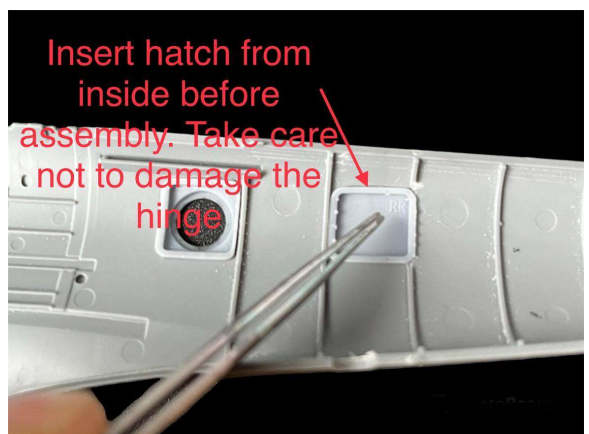

- Fuselage hatch (rear RH side): Use Part Marked RR located in plate 5 (the one inserted in the engine cage) Insert it upper side first, to clear the protruding hinge.

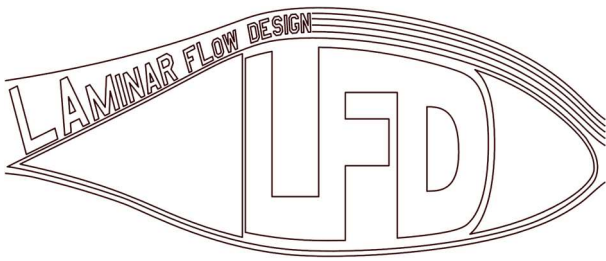

# Spitfire F/FR Mk XIVe Conversion

1/32 Conversion Set for Tamiya Spitfire MkXIVe "Low Back"

Laminar Flow Design  
 Email : [info@laminarflowdesign.com](mailto:info@laminarflowdesign.com)  
[www.laminarflowdesign.com](http://www.laminarflowdesign.com)



Fighter Recon Parts: Prepare 2 8mm diameter (+/-1mm Tol) round acetate sheets, and affix them to the camera ports from inside.

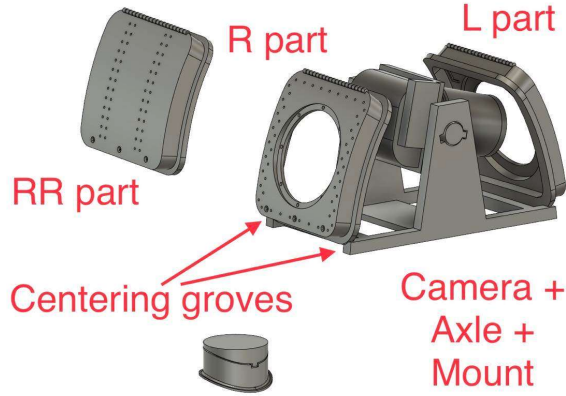

Assemble the support, axle and camera (you can choose the camera looking side)  
 Insert the camera hatches into the fuselage holes (the same way as previous step) Fix the camera assembly to the border of the hatches (self-centering grooves on the support)

○ Downward ID light:  
 Prepare 3 4mm diameter round acetate sheets and sandwich them into each light assembly. Slide the lights into position in the wings and fuselage. Take care of the fuselage lamp orientation, check picture. For better accuracy, you can color the acetate sheet

(amber center, ref left, green right).



- Painting and masks instructions:
  - Arrow indicates the front direction, R/L the side of the plane.
  - To avoid deformation during the mask application, apply a transfer tape over the masks during manipulation.
  - Mask borders are to be aligned with panel line to help the positioning. Check on the drawing for the relevant panel lines.

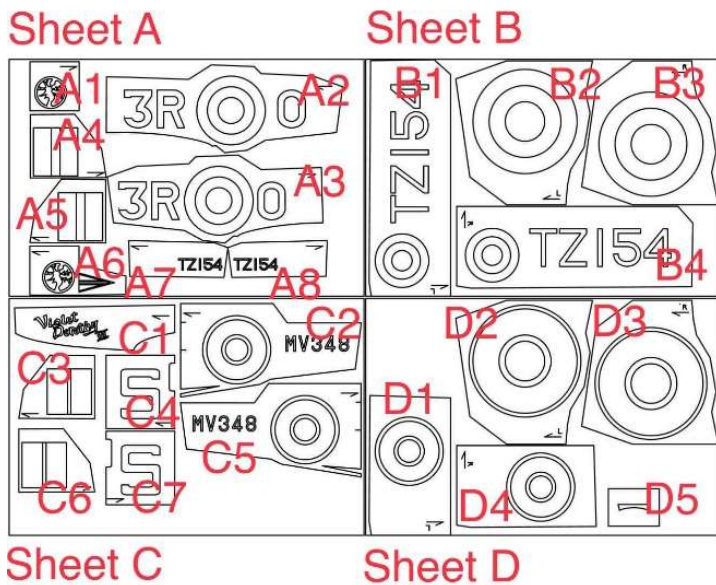
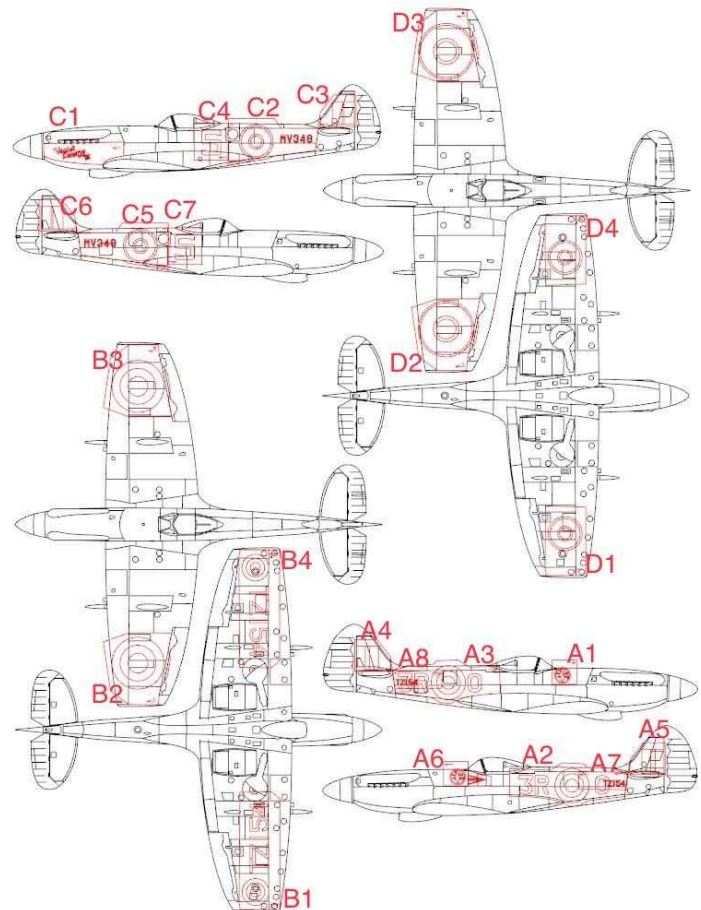

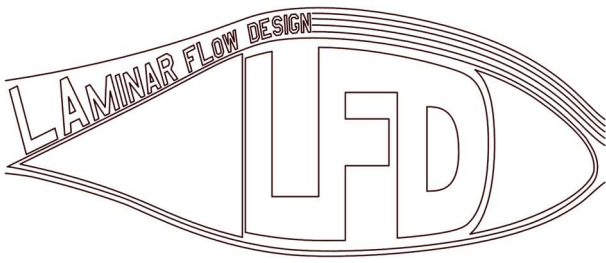

# Spitfire F/FR Mk XIVe Conversion

1/32 Conversion Set for Tamiya Spitfire MkXVIe "Low Back"

Laminar Flow Design  
 Email : [info@laminarflowdesign.com](mailto:info@laminarflowdesign.com)  
[www.laminarflowdesign.com](http://www.laminarflowdesign.com)

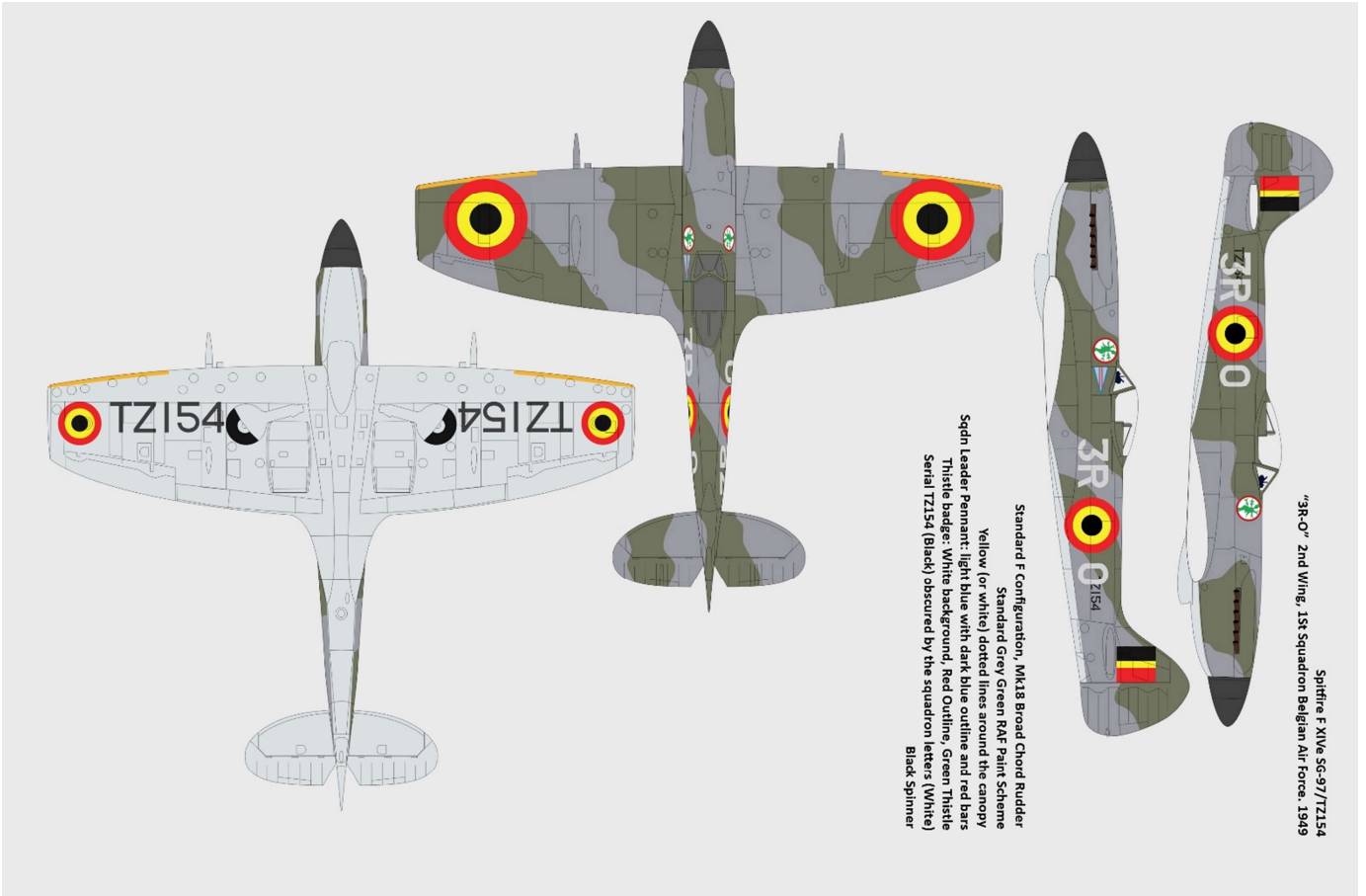

Standard F configuration, Mk18 Broad Chord Rudder  
 Standard Grey Green RAF Paint Scheme  
 Yellow (or white) dotted lines around the canopy  
 Sqn Leader Pennant: light blue with dark blue outline and red bars  
 Thistle badge: White background, Red Outline, Green Thistle  
 Serial TZ154 (Black) obscured by the squadron letters (White)  
 Black Spinner

Spitfire F Mk XIVe SG-97/TZ154  
 "ZR-O" 2nd Wing, 134 Squadron Belgian Air Force, 1949

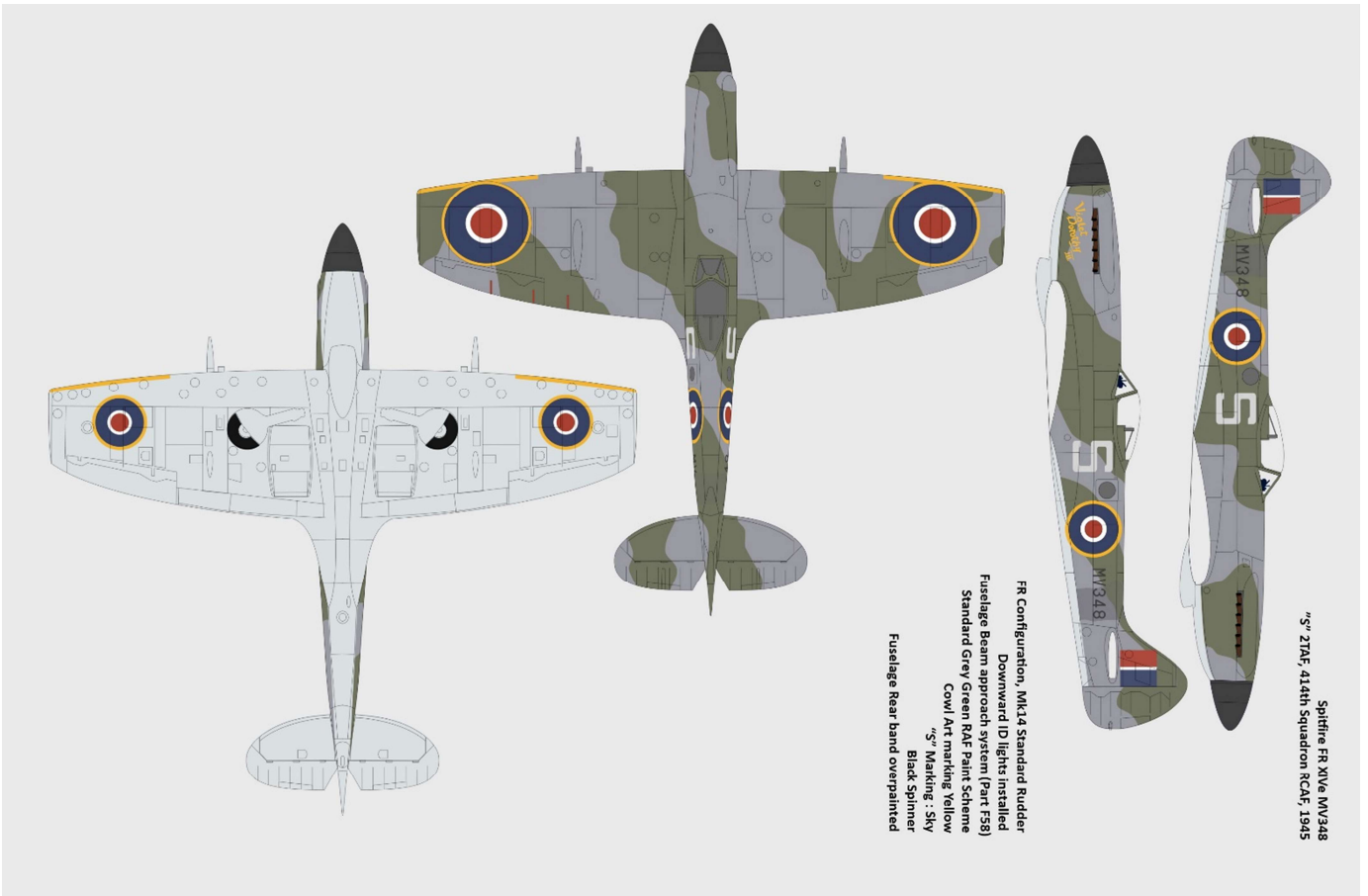

FR Configuration, Mk14 Standard Rudder  
 Downward ID lights installed  
 Fuselage Beam approach system (Part F58)  
 Standard Grey Green RAF Paint Scheme  
 Cowl Art marking: Yellow  
 "S" Marking: Sky  
 Black Spinner  
 Fuselage Rear band overpainted

Spitfire FR Mk XIVe MV348  
 "S" 27AF, 414th Squadron RCAF, 1945