

# Set AFV35-005

## AIRWAVES

### MERKAVA II

This detail set is manufactured from photo etched brass sheet and is meant for use on the Academy Minicraft model kit.

To separate components from frame use a sharp modelling knife on a firm surface, cutting as near to the part as possible. Tag scars can be cleaned by holding part in pliers and using a fine file. To fold part, support up to line of fold and, fold in one go, using a screwdriver blade for leverage. For assembly use superglue or five minute epoxy. Prior to painting ensure that parts are thoroughly cleaned by washing in detergent and that they are primed with either self etching primer or matt enamel. Position of parts in diagrams are for guidance only, for final positioning and colouring consult reference material.

Airwaves are distributed by E.D. Models, 64 Stratford Road, Shirley, Solihull, West Midlands B90 3LP, England. Telephone: 021-744-7488. Fax: 021-733-2591.

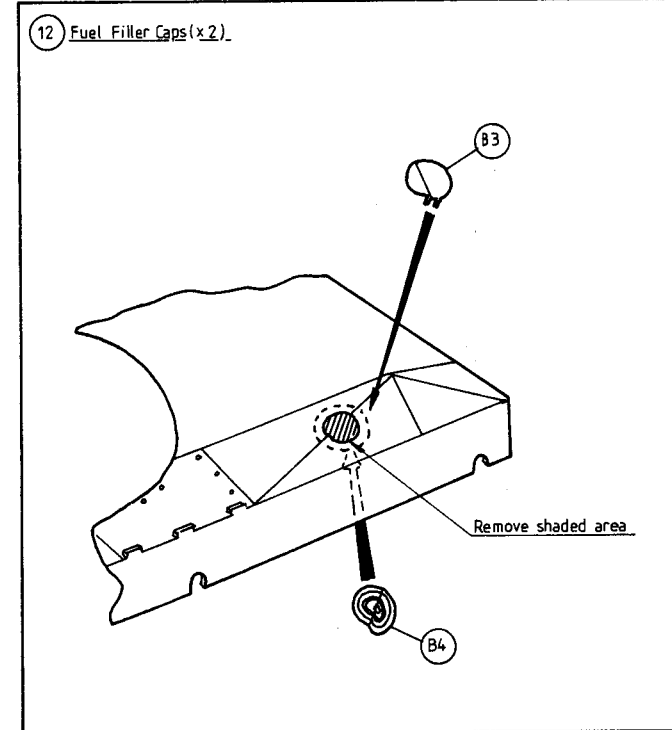
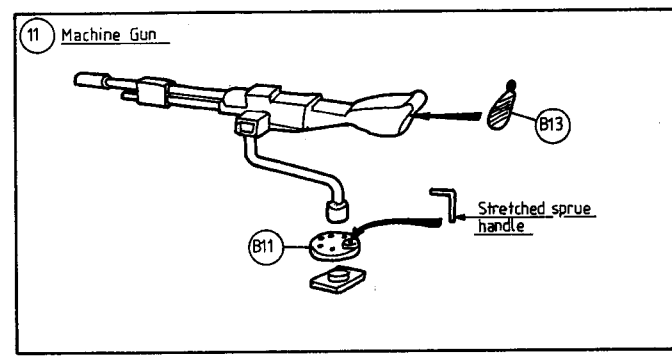
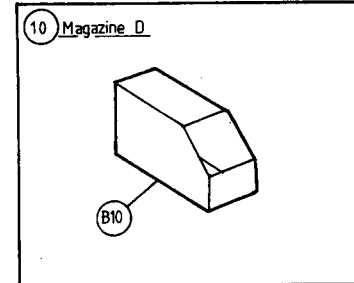
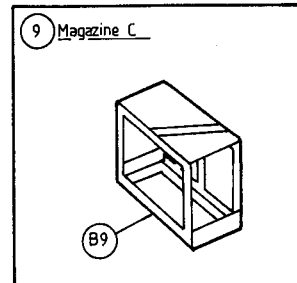
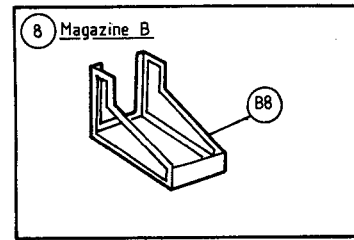
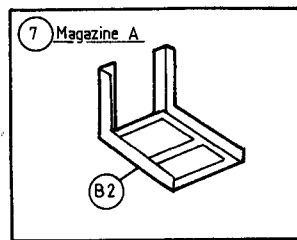
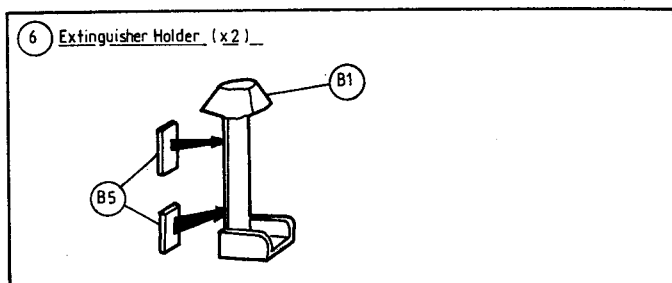
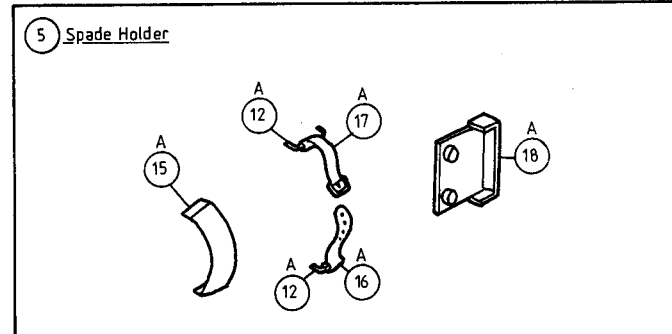
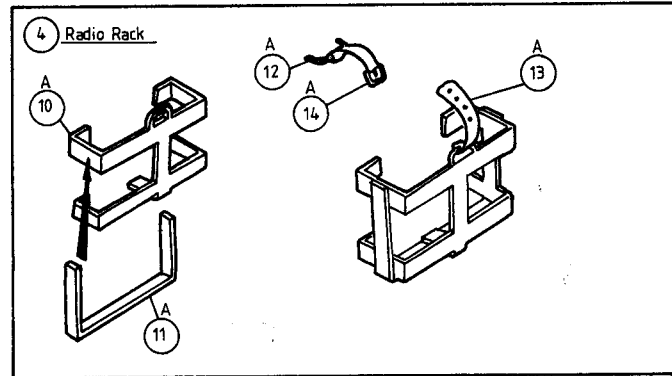
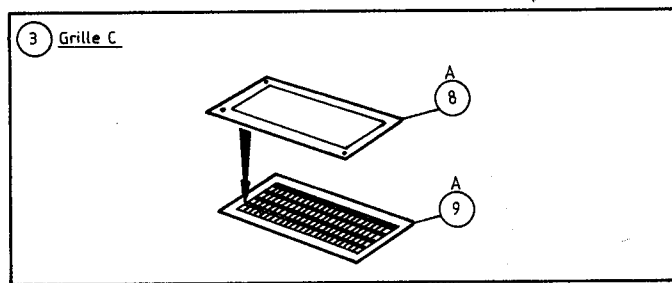
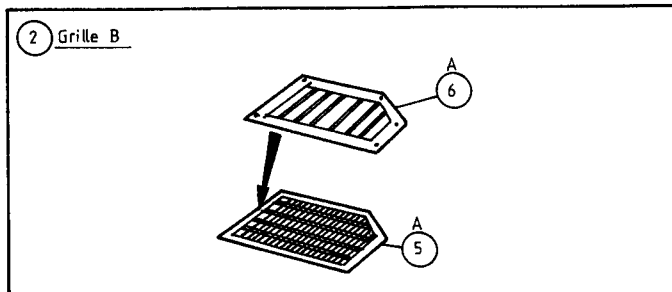
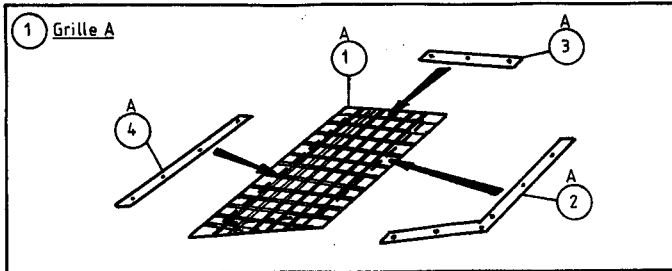

13 Assembly

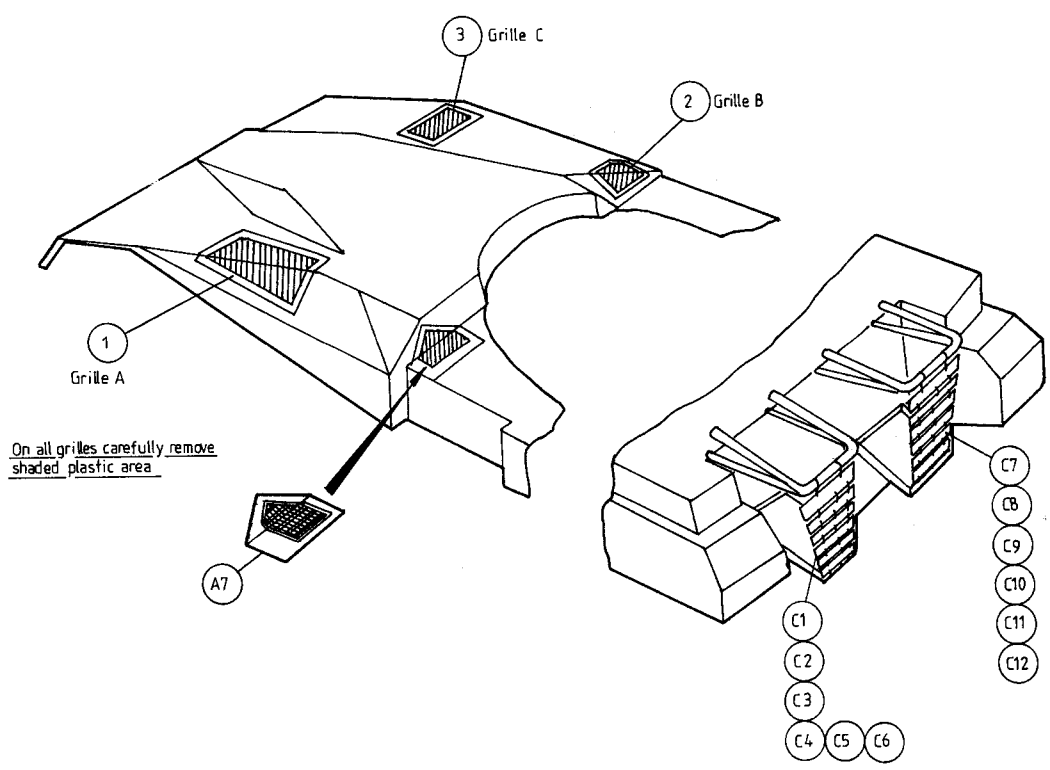
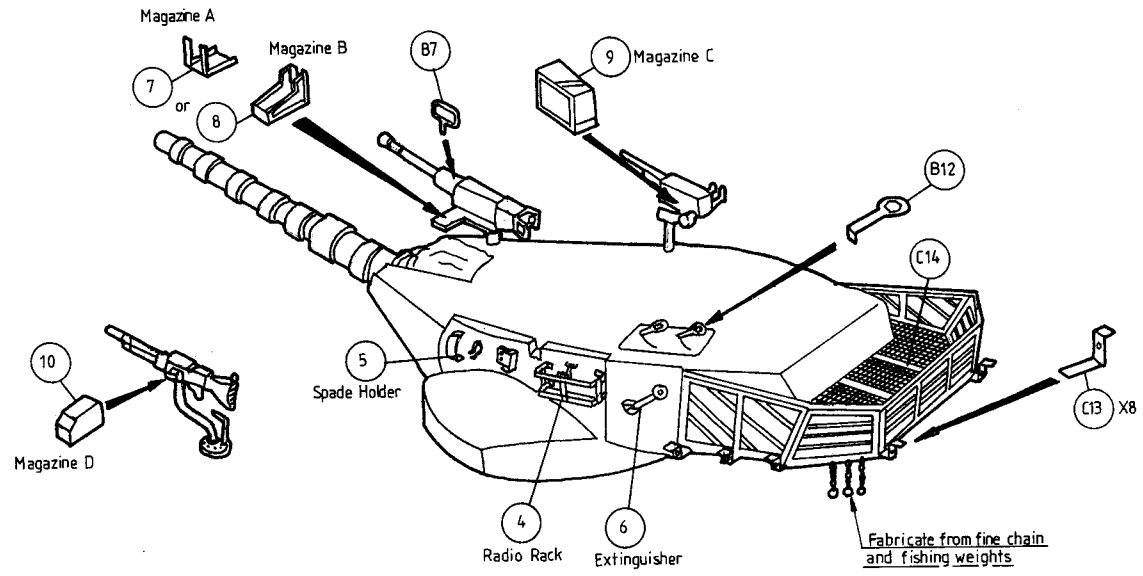

Link armour plate together with fine fusewire. Fabricate tray and frame from plastic rod and card. See separate sheet for full size template.

Component Frame Layout

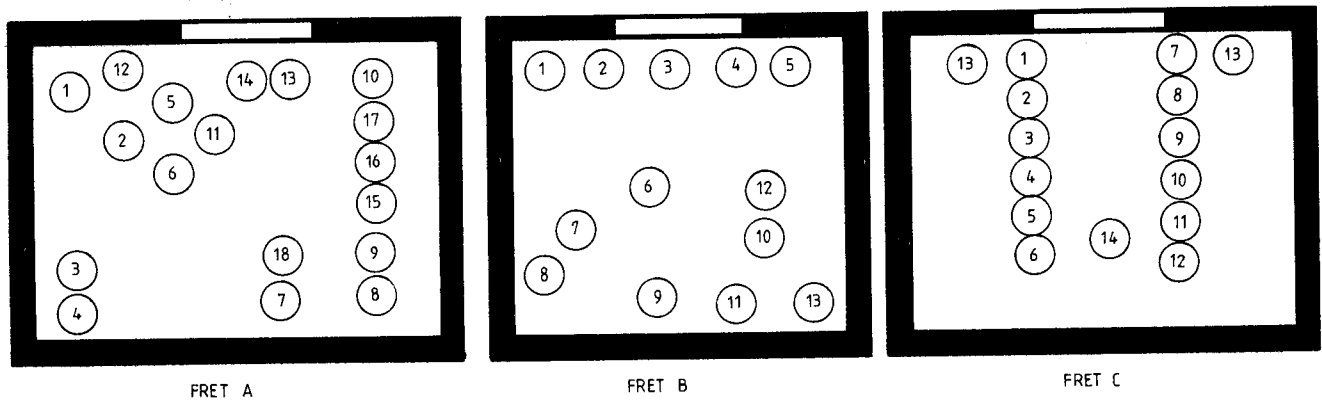

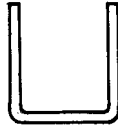

Rear Rack: 2 Required, 1 Right, 1 Left.

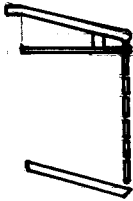

Scale 1:1

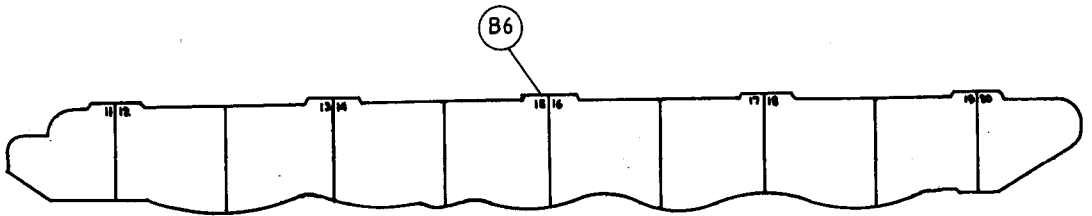

Side Armour

