



1:72 Boeing B-17G Flying Fortress™

A08017 SCALE MODEL CONSTRUCTION KIT | Wingspan: 438mm Fuselage Length: 320mm | Two Decal Schemes Included

GB

The Boeing B-17 'Flying Fortress' boasts a remarkable legacy, as both a strategic weapon and an enduring symbol of American air power during the Second World War. Designed as a large, multi-engine bomber with substantial defensive armament, the B-17 was introduced in 1938. First seeing combat with the RAF in 1941, where it was used to carry out bombing raids in France, its poor performance suggested that improved defences and greater bombing accuracy were needed if the B-17 was ever to be relied upon as a heavy bomber. Later variants like the B-17G proved more effective and it gradually became a potent strategic weapon, capable of carrying out high-altitude, long-range attacks. Despite heavy defensive armament B-17s still suffered at the hands of enemy fighters and it was only with the advent of long-range escort fighters that the losses became acceptable. In the Pacific, the B-17 established itself as a resilient fighting force, faring well under fierce Japanese attack from Pearl Harbour to the Philippines. In Europe as part of the Eighth Air Force, the B-17 also played a crucial role in the 'Combined Bomber Offensive', a joint USAAF-RAF strategic bombing operation against industrial and Luftwaffe targets throughout Germany

FR

L'histoire du Boeing B-17 Flying Fortress est remarquable : arme stratégique, il est devenu un symbole durable de la puissance aérienne américaine pendant la Deuxième Guerre mondiale. Conçu comme grand bombardier multi-moteurs muni d'un armement défensif impressionnant, le B-17 fut introduit en 1938. Ses premiers combats au sein de la RAF eurent lieu en 1941 lorsqu'on l'utilisa pour effectuer des missions de bombardement en France. Ses performances médiocres indiquèrent qu'il fallait améliorer ses défenses ainsi que la précision des bombardements pour qu'il soit considéré en tant que bombardier lourd fiable. Les variantes ultérieures comme le B-17G s'avèrent être plus performantes et l'appareil se transforma progressivement en arme stratégique puissante, capable de mener à bien des raids à haute altitude et à longue portée. Malgré leur armement lourd, les B-17 subirent des pertes aux mains des chasseurs ennemis jusqu'à l'arrivée des escortes à long rayon d'action. Dans le Pacifique, le B-17 s'établit comme une force de combat redoutable qui obtint de bons résultats contre les attaques acharnées des Japonais, depuis Pearl Harbor jusqu'aux Philippines. En Europe, au sein de la 8e Air Force, le B-17 joua un rôle primordial en participant à l'offensive de bombardement combinée, une opération USAAF-RAF de bombardement stratégique dirigée contre des cibles industrielles et des installations de la Luftwaffe partout en

DE

Die Boeing B-17 „Flying Fortress“ hinterlässt ein bemerkenswertes Vermächtnis als strategische Waffe und unvergängliches Symbol der amerikanischen Luftmacht im Zweiten Weltkrieg. Die als großer, mehrmotoriger Bomber mit umfangreicher Defensivbewaffnung entwickelte B-17 wurde 1938 eingeführt. 1941 griff sie bei der RAF ins Kampfgeschehen ein und führte Bombenangriffe in Frankreich aus: ihre schlechte Leistung legte nahe, dass verbesserte Abwehr und höhere Genauigkeit beim Bomben nötig waren, wenn auf die B-17 als schwerer Bomber je Verlass sein sollte. Spätere Varianten wie die B-17G erwiesen sich als wirksamer, und sie wurde allmählich eine potente strategische Waffe, die zu Distanzangriffen aus großer Höhe imstande war. Trotz der schweren Defensivbewaffnung setzten feindliche Jäger der B-17s weiterhin stark zu, und erst mit der Einführung von Langstrecken-Begleitjägern wurden die Verluste hinnehmbar. Im Pazifik war die B-17 robust und kampfstark und behauptete sich, von Pearl Harbour bis zu den Philippinen, gut gegen heftige japanische Angriffe. In Europa spielte die B-17 auch, als Bestandteil der 8. Air Force, eine entscheidende Rolle bei der „kombinierten Bomberoffensive“, einem gemeinsamen strategischen Bombereinsatz der USAAF und RAF gegen Industrie- und Luftwaffe-Ziele in ganz Deutschland

from 1943-1945. Of the 1.5 million tonnes of bombs dropped on German targets by USAAF aircraft, the B-17 alone was responsible for nearly seven-hundred thousand.

Specification

Maximum Speed: 287 mph (462km/h)

Range: 2,000 miles (3,219 km)

Wingspan: 103 ft 9 in (31.67m)

Length: 74 ft 9 in (22.83 m)

Armament: 13 x .50 in (12.7mm) Browning machine guns (2 in the chin turret, 2 on nose cheeks, 2 staggered waist guns, 2 in the upper Sperry turret, 2 in the ball turret, 2 in the tail and one in the radio compartment). 8000 lb of bombs

Allemagne pendant les années 1943-45. Sur un total de 1,5 million de tonnes de bombes larguées sur des cibles allemandes par les bombardiers de l'USAAF, les B-17 tout seuls en lancèrent presque sept cent mille.

Spécification:

Vitesse maximale: 462 km/h

Autonomie: 3.219 km

Envergure: 31,67 m

Longueur: 22,83 m

Armement: Treize mitrailleuses Browning de 12,7 mm dont deux dans la tourelle de menton, deux de 'joue' montées sur chaque côté du nez, deux sans les sabords latéraux, deux dans la tourelle supérieure Sperry, deux dans la tourelle ventrale, deux à l'arrière et une à l'emplacement du poste radio. 3.630 kg de bombes

von 1943-1945. Von den 1,5 Mio. Tonnen an Bomben, die von USAAF-Flugzeugen auf deutsche Ziele abgeworfen wurden, entfielen fast 700.000 allein auf die B-17.

Spezifikation:

Höchstgeschwindigkeit: 462 km/h

Reichweite: 3.219 km

Spannweite: 31,67 m

Länge: 22,83 m

Bewaffnung: 13 Browning-Maschinengewehre 12,7 mm (2 im Kinnrump, 2 an Bugwangen, 2 seitlich versetzt angeordnet, 2 im oberen Sperry-Turm, 2 im Kugelturm, 2 im Heck und 1 im Funkabteil). 3600 kg an Bomben

Airfix would like to express their thanks to IWM Duxford, The Smithsonian, Lynn Ritger, Jon Brawner, Karl Hauffe, Roy Sutherland and Jan Zdiarský for their help with the development of this product.



B-17 Flying Fortress™

Produced under License. Boeing, B-17 Flying Fortress, the distinctive Boeing logos, product markings and trade dress are trademarks of The Boeing Company.

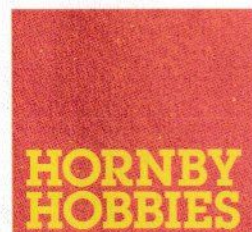

FOR BEST RESULTS:

Surfaces to be painted should be clean – before parts are removed from the sprue, wash in warm, soapy water, rinse and dry thoroughly. Stir paints thoroughly before use.

PLEASE NOTE:

Some parts in the kit may not be required to build the model specified.



ES El Boeing B-17 'Fortaleza Volante' puede presumir de un magnífico legado, como arma estratégica y como símbolo duradero del poder estadounidense durante la Segunda Guerra Mundial. El B-17, diseñado como gran bombardero con varios motores y con un fuerte armamento defensivo, se introdujo en 1938. Tras sus primeras misiones de combate con la RAF en 1941 en bombardeos sobre Francia, su escaso rendimiento sugirió que sería preciso mejorar las defensas y aumentar la precisión en el bombardeo para poder considerar seriamente el uso del B-17 como bombardero pesado. Variantes posteriores como la B-17G demostraron una mayor efectividad, y con el tiempo se convirtió en una potente arma estratégica, capaz de llevar a cabo ataques a gran distancia y desde elevada altitud. A pesar de su fuerte armamento defensivo, los B-17 siguieron sufriendo a manos de los cazas enemigos y las pérdidas solo llegarían a ser aceptables con la introducción de cazas escolta de gran autonomía. En el Pacífico, el B-17 destacó como aparato de gran resistencia, capaz de resistir los implacables ataques japoneses desde Pearl Harbour hasta las Filipinas. En Europa, integrado en la Octava Fuerza Aérea, el B-17 también tuvo un papel crucial en la 'Ofensiva combinada de bombardeo', una operación estratégica conjunta USAAF-RAF contra objetivos industriales y de la Luftwaffe sobre toda la geografía alemana entre 1943 y 1945. El B-17 fue

responsable de casi 700 000 de los 1,5 millones de toneladas de bombas lanzadas sobre objetivos alemanes por aparatos de la USAAF.

Especificación:

Velocidad máxima: 462 km/h
 Autonomía: 3219 km
 Envergadura: 31,67 m
 Longitud: 22,83 m
 Armamento: 13 ametralladoras Browning de 12,7 mm (2 en la torreta ventral, 2 en posiciones laterales delanteras, 2 escalonadas en posición central, 2 en la torreta Sperry superior, 2 en la torreta dorsal, 2 en cola y una en el compartimento de radio). 3600 kg de bombas

SE Boeing B-17, eller "Flying Fortress", har ett ärorikt förlutet både som ett strategiskt vapen och en bestående symbol för den amerikanska flyginsatsen under andra världskriget. B-17, som introducerades 1938, utformades som ett stort flermotorigt bombplan med omfattande defensiv beväpning. Första gången det sattes in i strid var 1941 då RAF genomförde bombträder i Frankrike. Dess bristande framgångar visade dock på att förbättrade defensiva funktioner och mer precisionsmässig bombning krävdes om B-17 någonsin skulle bli tillförlitlig som tungt bombplan. Senare varianter som B-17G visade sig vara mer effektiva och utvecklades gradvis till användbara strategiska vapen som kunde genomföra uppdrag på hög höjd och med lång räckvidd. Trots den tunga defensiva beväpningen led B-17-planen nya nederlag mot fiendens jaktplan, och det var endast introduktionen av eskorterande jaktplan med lång räckvidd som sänkte förlustsiffrorna. I stillahavsområdet, från Pearl Harbour till Filippinerna, utgjorde B-17 en slitstrak resurs som gjorde väl ifrån sig under de japanska attackerna. Som en del av Eighth Air Force i Europa spelade B-17 även en viktig roll under "Combined Bomber Offensive", en strategisk bombkampanj från USAAF och RAF mot

industriella och Luftwaffe-mål i Tyskland 1943-1945. Av de 1,5 miljoner ton bomber som släpptes över tyska mål från USAAF-plan svarade B-17 för nästan 700 000.

Spekifikation:

Maximal hastighet: 462 km/h
 Räckvidd: 3219 km
 Spännvidd: 31,67 m
 Längd: 22,83 m
 Bestyckning: 13 st. 12,7 mm Browning-kulsprutor (2 i nostornet, 2 i nosen, 2 i sidan, 2 i övre Sperry, 2 i gondolen, 2 i stjärten och 1 i radiatorummet). 3 629 kg bomber

Assembly Instructions

GB Study drawings and practise assembly before cementing parts together. Carefully scrape paint from cementing surfaces. All parts are numbered. Paint small parts before assembly. To apply decals cut sheet as required, dip in warm water for a few seconds, slide off backing into position shown. Use in conjunction with box artwork. Not appropriate for children under 36 months of age, due to the presence of small detachable parts.

FR Étudier attentivement les dessins et simuler l'assemblage avant de coller les pièces. Gratter soigneusement toute peinture sur les surfaces à coller. Toutes les pièces sont numérotées. Peindre les petites pièces avant l'assemblage. Pour coller les décalcomanies, découper le motif, le plonger quelques secondes dans de l'eau chaude puis le poser à l'endroit indiqué en décollant le support papier. Utiliser conjointement avec les illustrations sur la boîte. Ne convient pas aux enfants de moins de 36 mois - présence de petits éléments détachables.

DE Vor dem Zusammenkleben der Teile die Zeichnungen sorgfältig ansehen und die zu verklebenden Teile zur Vermeidung möglicher Fehler versuchsweise zusammenfügen. Dann an den Klebeflächen vorhandene Farbeschichtung vor dem Zusammenkleben vorsichtig abkratzen. Alle Bestandteile sind mit Nummern versehen. Kleine Teile vor dem Zusammenbau bemalen. Abziehbilder wie gewünscht ausschneiden. Vor dem Anbringen einige Sekunden in warmes Wasser tauchen und dann vom Trägerpapier in ihre vorgesehene Position schieben. Dabei die Abbildungen auf der Schachtel beachten. Nicht für Kinder unter 36 Monaten geeignet, da abnehmbare bzw. lose angebrachte Kleinteile enthalten sind.

ES Estudiar los dibujos y practicar el montaje antes de pegar las piezas. Raspar cuidadosamente la pintura en las superficies de contacto antes de pegar las piezas. Todas las piezas están numeradas. Es conveniente pintar las piezas pequeñas antes de su montaje. Para aplicar las calcomanías, cortarlas de la hoja, sumergirlas en agua tibia durante unos segundos y deslizarlas a la posición indicada. Utilizar en conjunción con la ilustración de la caja. No es adecuado para niños menores de 36 meses, ya que contiene piezas pequeñas que podrían soltarse.

IT Studiare i disegni ed esercitarsi a montare i vari pezzi prima di fissarli con la colla. Raschiare con cura le tracce di vernice dalle superfici da incollare. Tutti i pezzi sono numerati. Verniciare i pezzi di piccole dimensioni prima di montarli. Per applicare le decalcomanie, ritagliare il foglio nel modo richiesto, immergere in acqua calda per alcuni secondi, quindi staccare la decalcomania dalla carta di supporto e posizionarla nel punto desiderato. Usare le decalcomanie come indicato nell'illustrazione riportata sulla confezione. Non adatto a bambini di età inferiore a 36 mesi per la presenza di componenti di piccole dimensioni che potrebbero staccarsi.

DK Studér tegningerne nøje og forsøg at sætte delene sammen, inden de klæbes sammen. Skrab forsigtigt malingen af de overflader, der skal klæbes sammen. Alle dele er nummererede. Små dele skal males, før de monteres. Overføringsbillederne påføres ved at klippe dem ud af arket, som påkrævet, dyppe dem i varmt vand i nogle få sekunder, hvorefter underlaget glides af i de viste positioner. Påføres ifølge illustrationerne på æsken. Ikke egnet til børn under 3 år på grund af tilstedeværelse af små aftagelege dele.

NL Tekeningen bestuderen en delen in elkaar zetten alvorens deze te lijmen. Lak voorzichtig van lijmvlakken afschrapen. Alle delen zijn genummerd. Kleine delen vóór montage verven. Voor aanbrengen van stickers, gewenste stickers uit het vel knippen, een paar seconden in warm water dompelen en dan van het schutblad af op afgebeelde plaats schuiven. Hierbij afbeelding op doos raadplegen. Niet geschikt voor kinderen onder 3 jaar, omdat kleine deeltjes gemakkelijk kunnen losraken.

SE Studera bilderna noggrant och sätt ihop delarna innan du limmar ihop dem. Skrapa försiktigt bort färg från limmade delar. Alla delarna är nummerade. Måla smådelarna före ihopsättning. Sätt fast dekalerna genom att klippa arket, doppa i varmt vatten några sekunder och låta baksidan glida på plats som bilden visar. Använd enligt bildanvisningarna på kartongen. Rekommenderas ej för barn under 3 år. Innehåller lösttagbara smådelar.

FI Tutustu piirroksiin ja harjoittele kokoamista, ennen kuin liimaat osat yhteen. Raaputa maali varovasti pois liimattavilta pinnoilta. Kaikki osat on numeroitu. Maalaa pienet osat ennen kokoamista. Siirtokuvien kiinnittämiseksi leikkaa ne arkista tarpeen mukaan. Kasta kuva lämpimään veteen muutaman sekunnin ajaksi, anna takapuolen liukua kuvalle osoitettuun kohtaan. Käytetään yhdessä laatikon kuvituksen kanssa. Ei suositella alle kolmivuotiaille lapsille. Paljon irrotettavaa pikkusuasia.

PT Estudiar atentamente os desenhos e experimentar a montagem. Raspar cuidadosamente as superfícies de modo a eliminar pintura antes de colar. Todas as peças estão numeradas. Pintar as pequenas peças antes de colar. Para aplicar as decalcomanias, cortar as folhas e mergulhar em água morna por alguns segundos, depois deslizar e aplicar no respectivo lugar, como indicado nas ilustrações na caixa. Não convém a uma criança de menos de 36 meses devido à presença de pequenos elementos destacáveis.

PL Przed przystąpieniem do sklejania przestuduj uważnie rysunki i przećwicz składanie części. Ostrożnie zeskrub ze sklejalnych powierzchni farbę. Wszystkie części są ponumerowane. Drobnie części pomaluj przed ich złożeniem. Celem przeniesienia kalkomanii wytnij ją z arkusza, zanurz na kilka sekund w letniej wodzie i zsuni z podłoża na wymagane miejsce. Używaj w połączeniu ze wzorami na pudełku. W związku z obecnością wielu drobnych, rozbieralnych części, nieodpowiednie dla dzieci poniżej 3 lat.

EL Μελετήστε προσεκτικά τα σχέδια και συναρμολογήστε για πρώτη φορά τα κομμάτια χωρίς να τα συγκολλήσετε. Αφαιρέστε επιμελώς την πλαστική βαφή από τις επιφάνειες τις οποίες θα συγκολλήσετε. Όλα τα κομμάτια είναι αριθμημένα. Χρωματίστε τις χαλκομανίες, κόψτε γύρω από το σχέδιο όπως αποτελείται, βυθίστε το μερικά δευτερόλεπτα σε χλιαρό νερό και μετά τοποθετήστε το στη θέση που υποδεικνύεται, αφαιρώντας τη μεμβράνη που το καλύπτει. Λάβετε υπόψη σας ταυτόχρονα την εικονογράφηση του κουτιού. Ακατάλληλο για παιδιά ηλικίας κάτω των 36 μηνών λόγω ύπαρξης μικρών κομματιών που αποσπώνται.

ASSEMBLY ICON INSTRUCTIONS

<p>Assembly phase Phase de montage Montagephase Fase de montaje Monteringsfasen Fase di montaggio Montagefase Fase de montagem Monteringsfase Kokoamisvaihe Faza składowania Φάση συναρμολόγησης</p>	<p>Cement Coller Kleben Pegar Limma Incollare Lijmen Colar Klæbes Liimaa Kleić Συγκολλήστε</p>	<p>Do not cement together No pas coller Nicht kleben No pegar Limma inte Non incollare Niet lijmen Nao colar Skaf ikke klæbes Alå limaa Nie kleić Μη συγκολλήστε</p>	<p>Indicates final location Indique l'emplacement final Zeigt Endposition mitgeliefert Indica la ubicación definitiva Anger slutmonteringsplats Sede di montaggio finale Geeft uiteindelijke locatie aan Indica localização final Viser endelig placering Osoittaa lopullisen sijainnin Oznacza miejsce docelowe Υποδεικνύει τελική τοποθεσία</p>	<p>Alternative part(s) provided Autre(s) pièce(s) fournie(s) Ersatzteile) mitgeliefert Se incluye(n) pieza(s) alternativa(s) Alternativ(a) del(ar) ingår Uno o più componenti alternativi forniti Alternatieve onderdelen meegeleverd Peça(s) alternativa(s) fornecida(s) Alternativ(e) del(e) medfølger Vaihtoehtoiset osat pakkauskassa Dostępne części zamienne Παρέχονται εναλλακτικά κομμάτια</p>	<p>Repeat this operation Répéter l'opération Vorgang wiederholen Repetir la operación Upprepa åtgärden Ripetere l'operazione De verrichting herhalen Repétir a operação Manövern gentages Toista toimenpidettä Powtórz operację Επανάλαβε τη διαδικασία</p>
<p>Decals Décalcomanies Abziehbild Calcomanías Dekaler Decalcomanie Stickers Decalcomania Billedoverføring Siirtokuvat Kalkomanie Χαλκομανίες</p>	<p>Crystal part Pièce cristal Kristallteil Pieza de cristal Kristalldel Pezzo cristallo Kristallen onderdeel Peça de cristal Krystalstykke Kristalliosa Część kryształowa Κομμάτι κρυστάλλου</p>	<p>Weight Lester Beschweren Lastar Belasta Applicare un peso Verzwaren Lastar Påfør vægt Aseta vastapaino Obciążyć balastem Επιθέστε βάρος</p>	<p>Remove by filing Enlever avec une lime Abfeilen Eliminar con lima Ta bort genom att fila Rimuovere con la lima Verwijderen door afvijlen Remova limando Fjern ved at file væk Poista viilaamalla Usunąć przy użyciu pilnika Αφαιρέστε λιμάροντας με λίμο</p>	<p>Drill or pierce Percer Durchbohren Perforar Borra Trapanare o forare Boren of doorboren Furar Gennembor Porać tai puhkaise Wywierć lub przedziurawić Τρυπήστε</p>	<p>Humbrol paint number No peinture Humbrol Humbrol-Farbnummer No de pintura Humbrol Humbrol färg nummer No vernice Humbrol Humbrol verfnummer No de pintura Humbrol Humbrol malfingsnummer Humbrol-maalin numero Nr farby Humbrol Número cromático Humbrol</p>

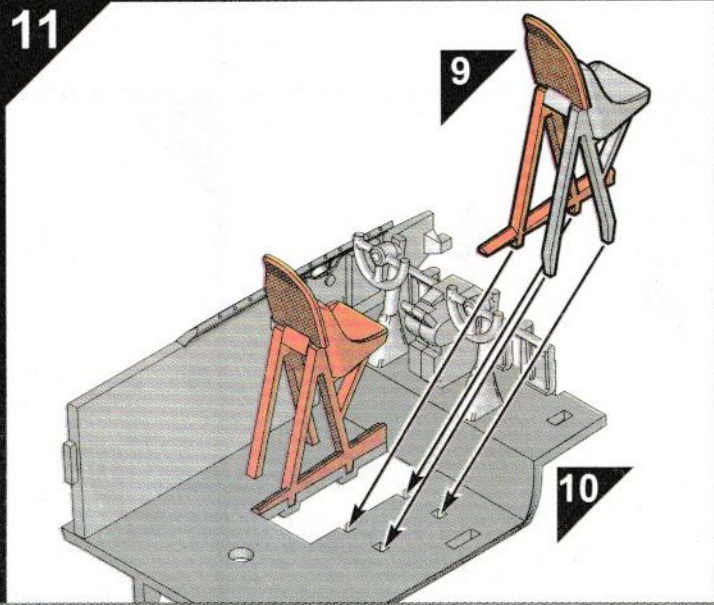
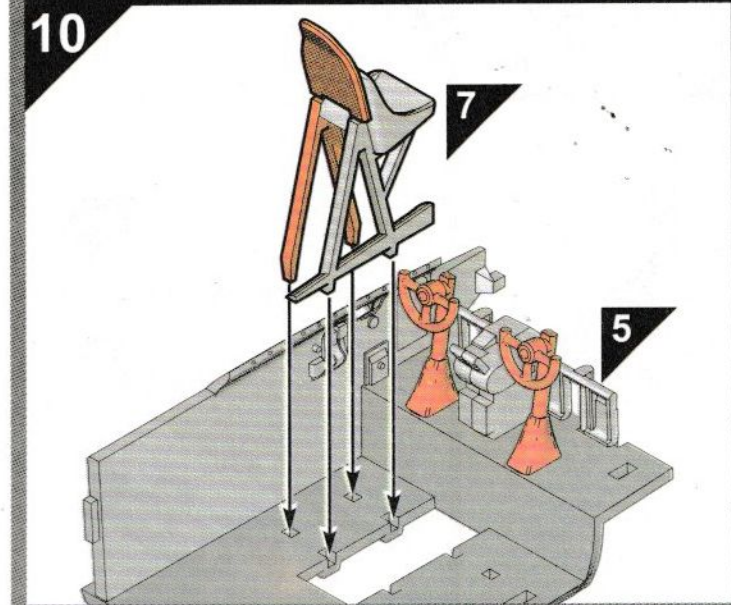
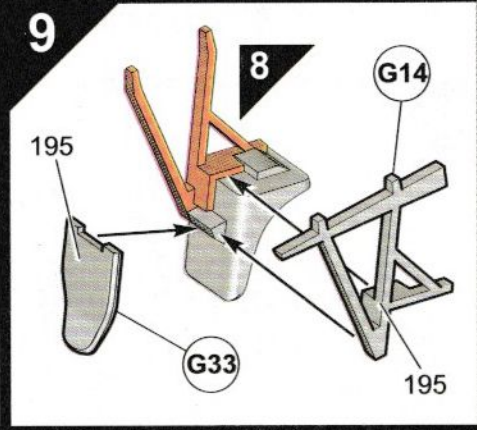
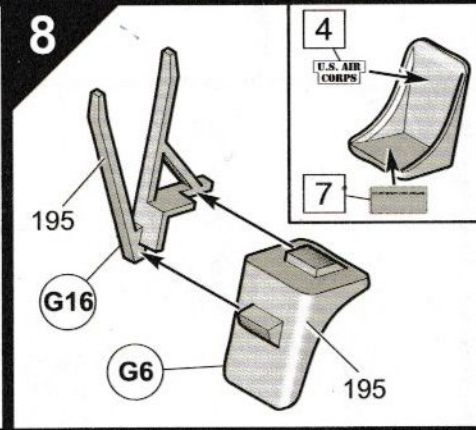
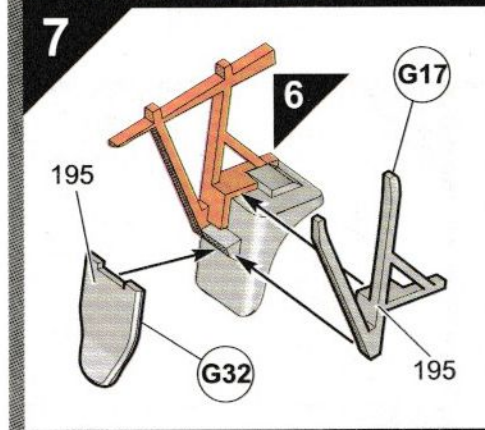
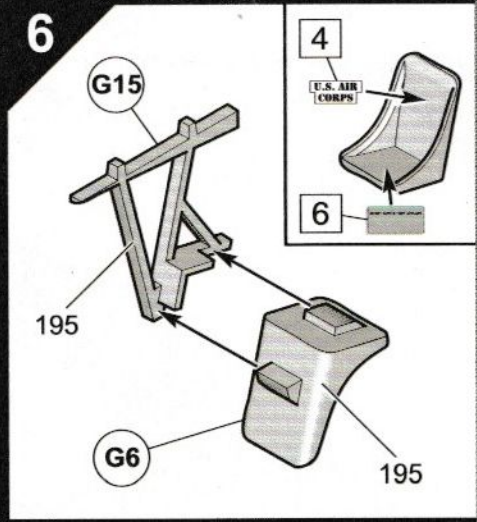
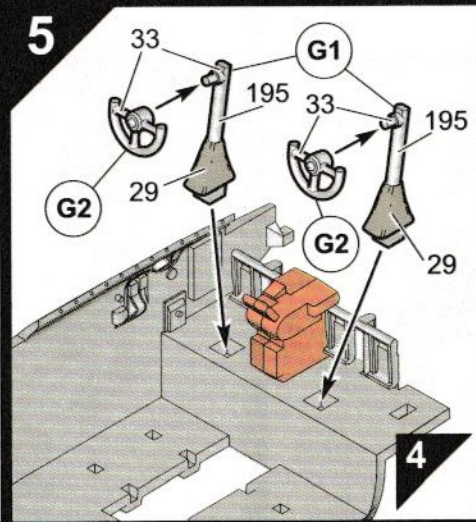
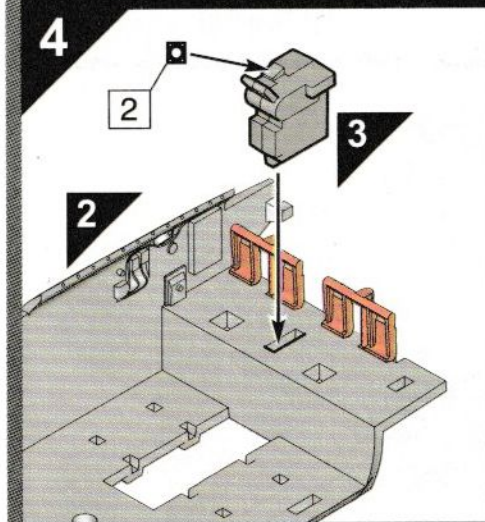
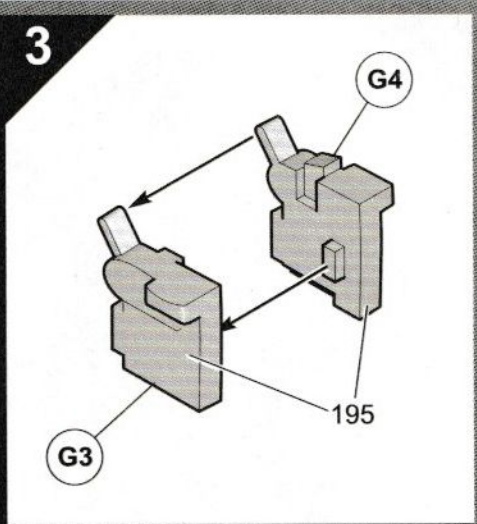
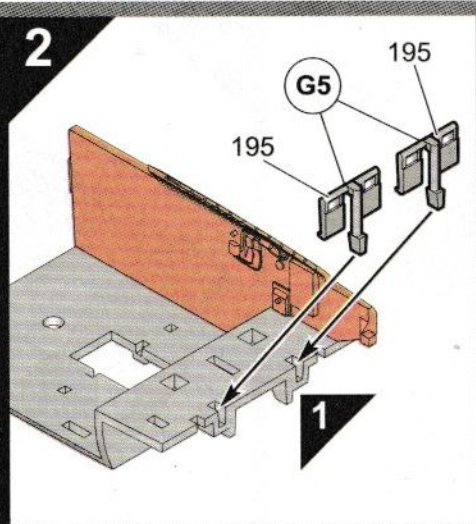
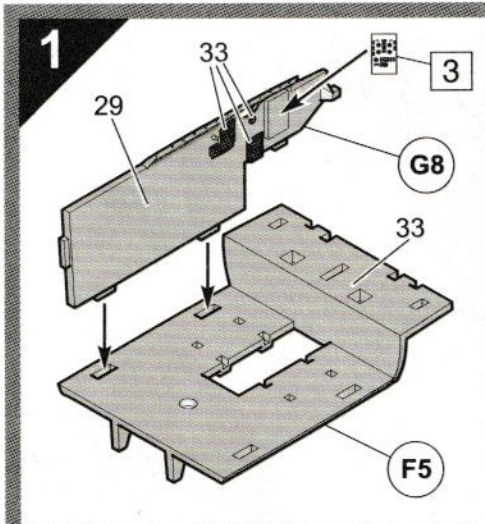

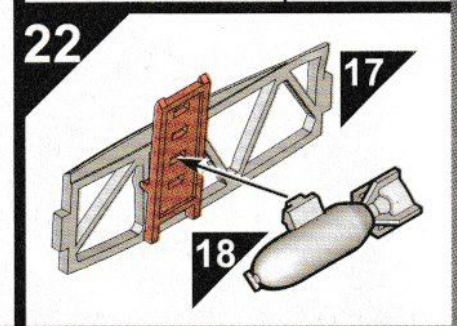
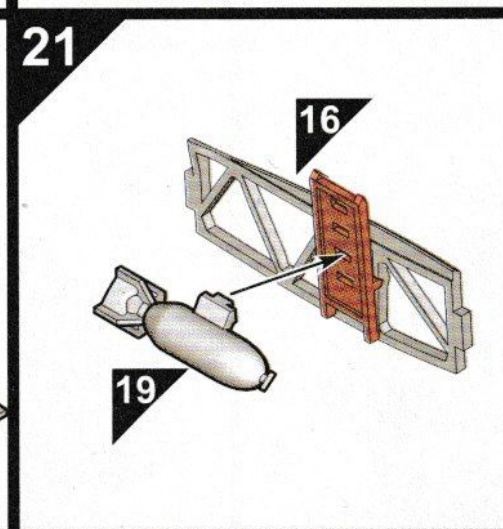
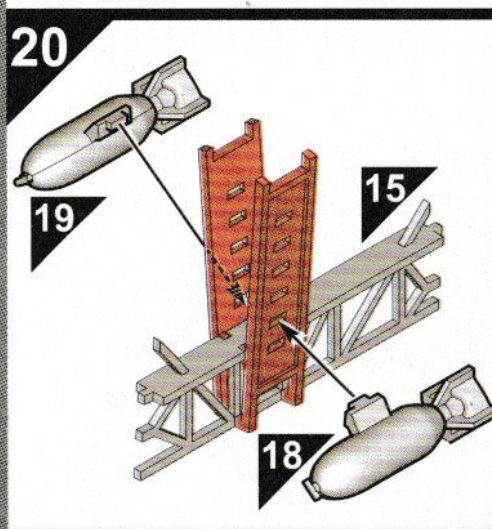
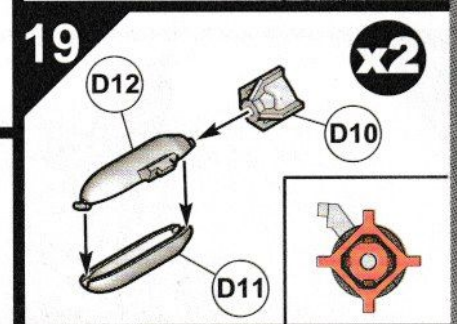
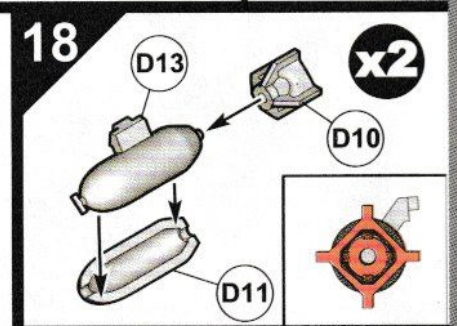
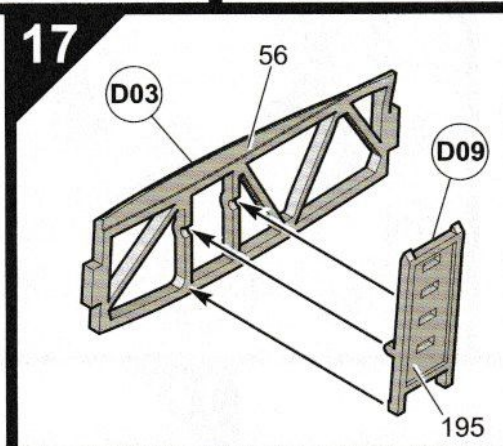
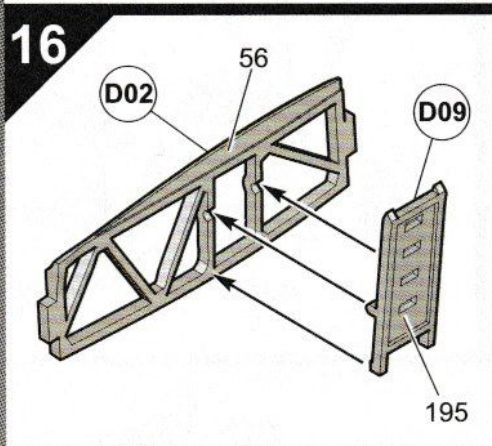
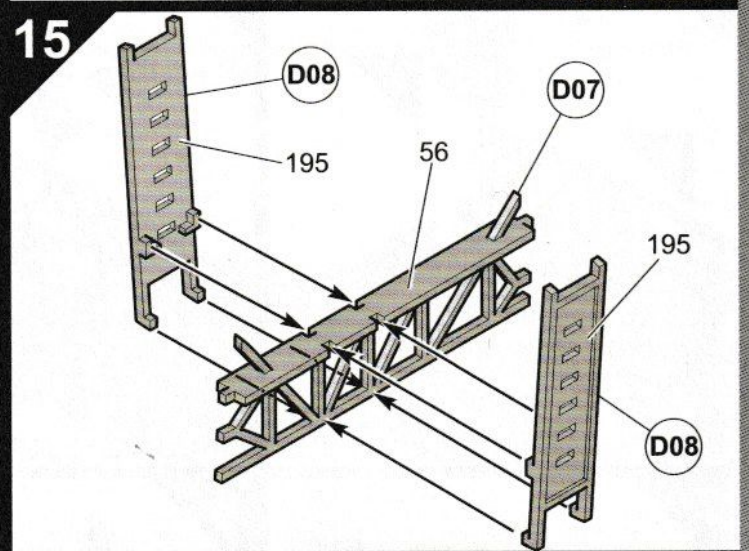
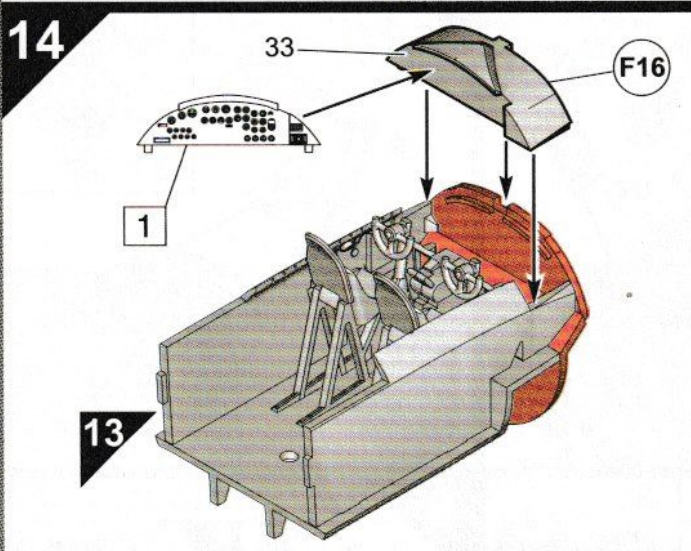
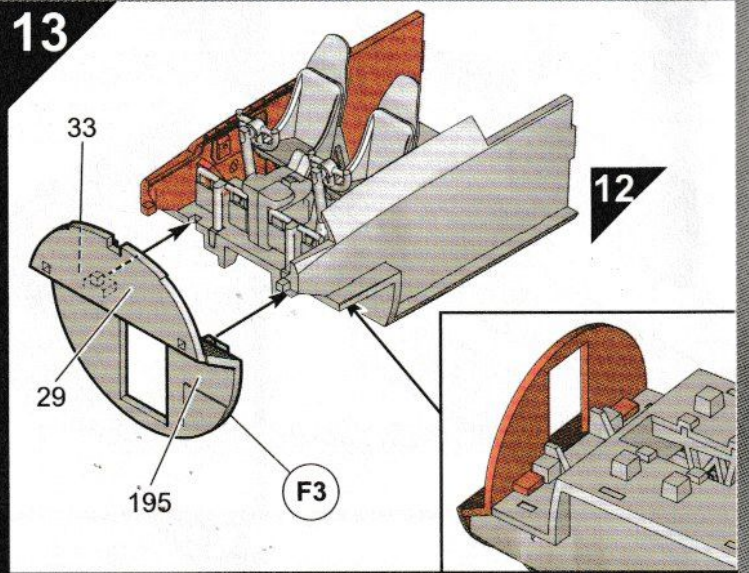
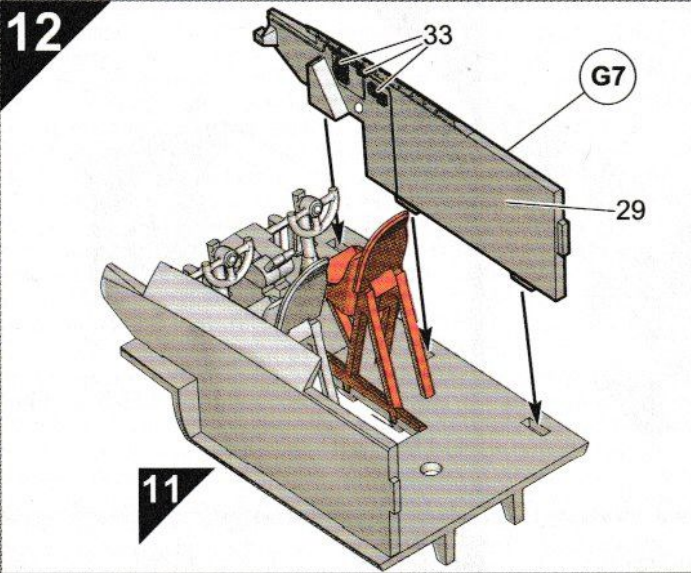

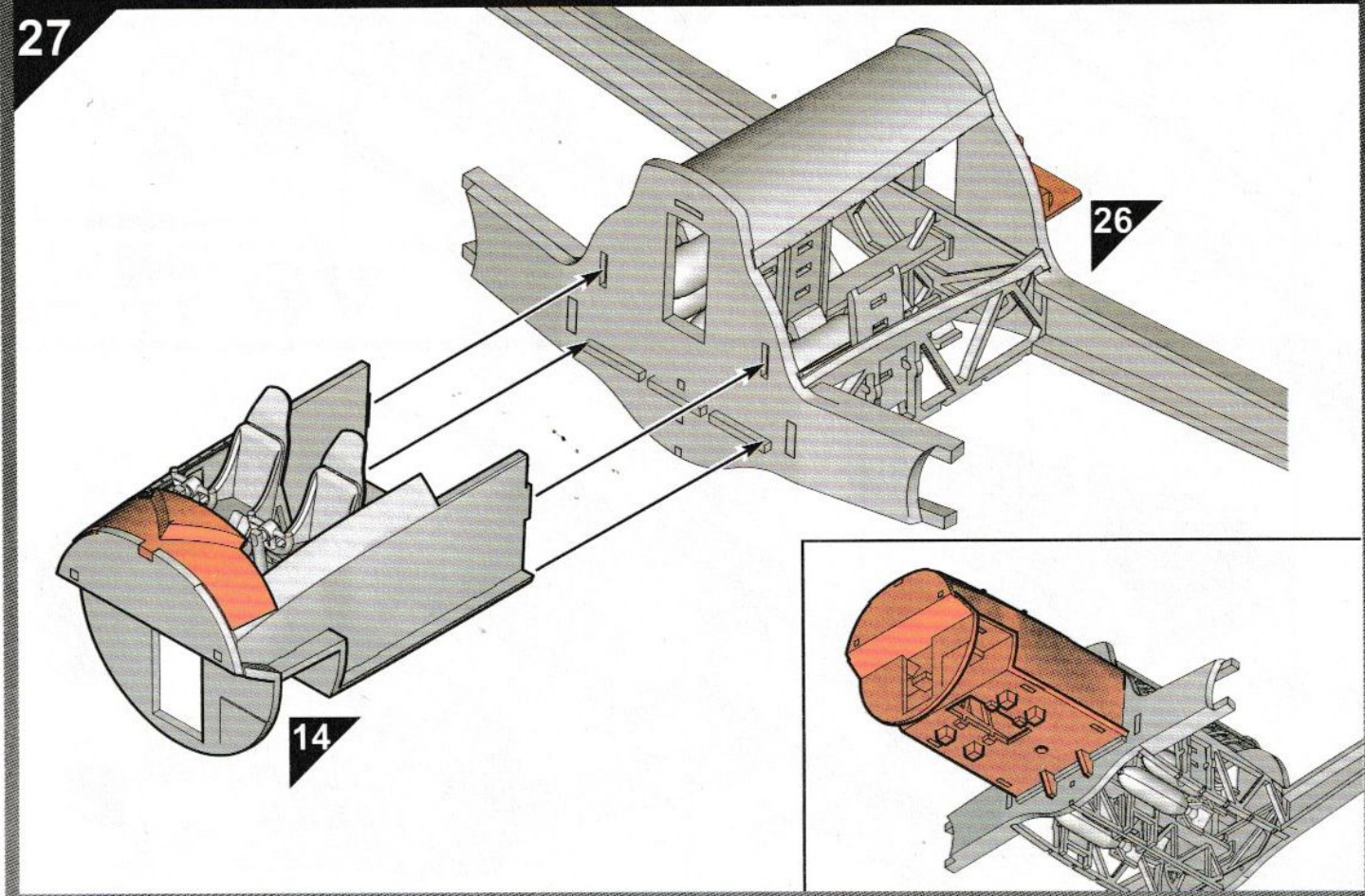
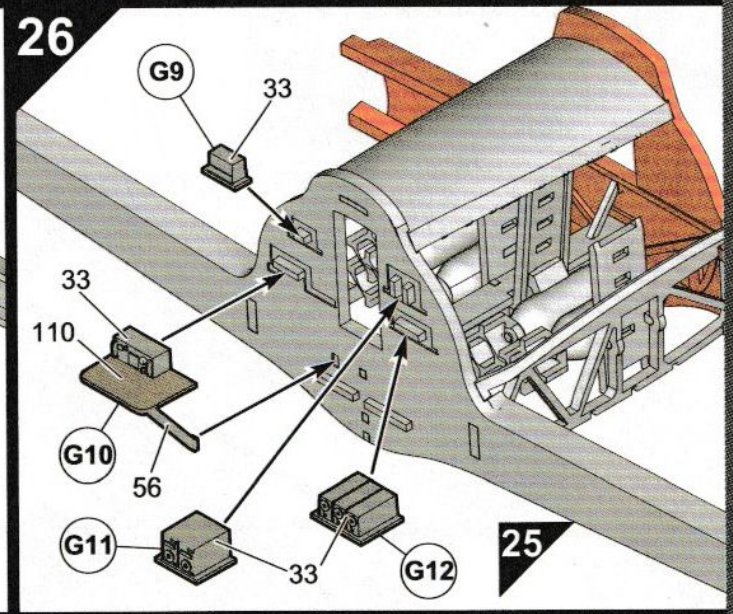
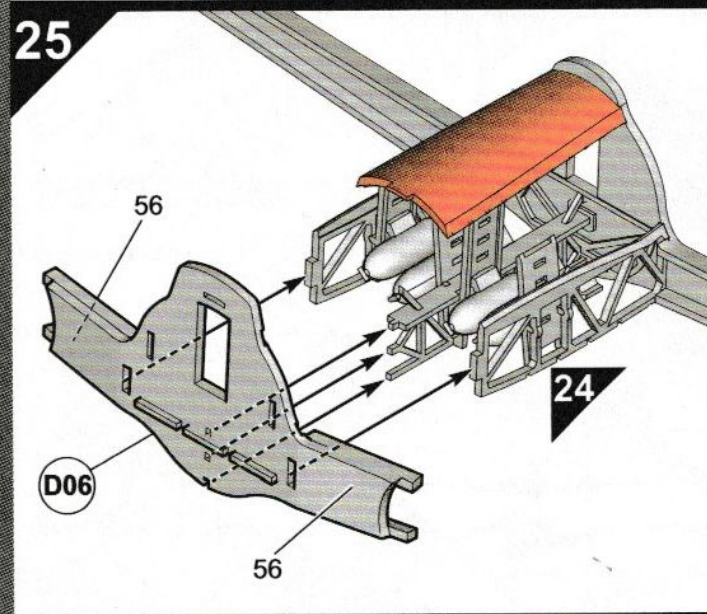
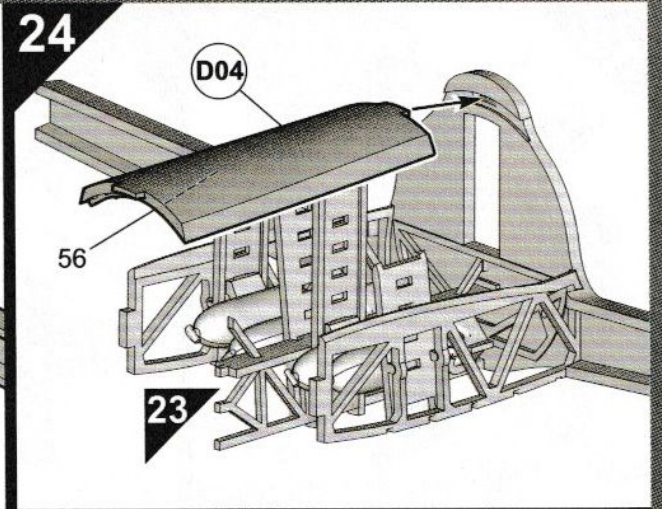
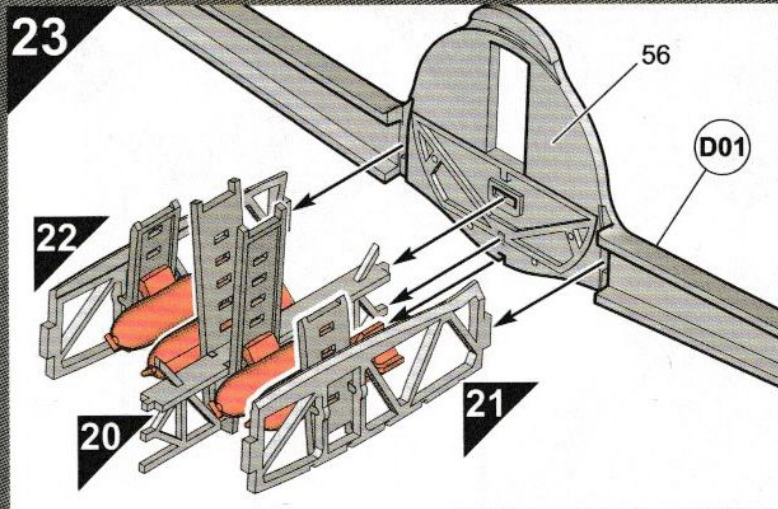

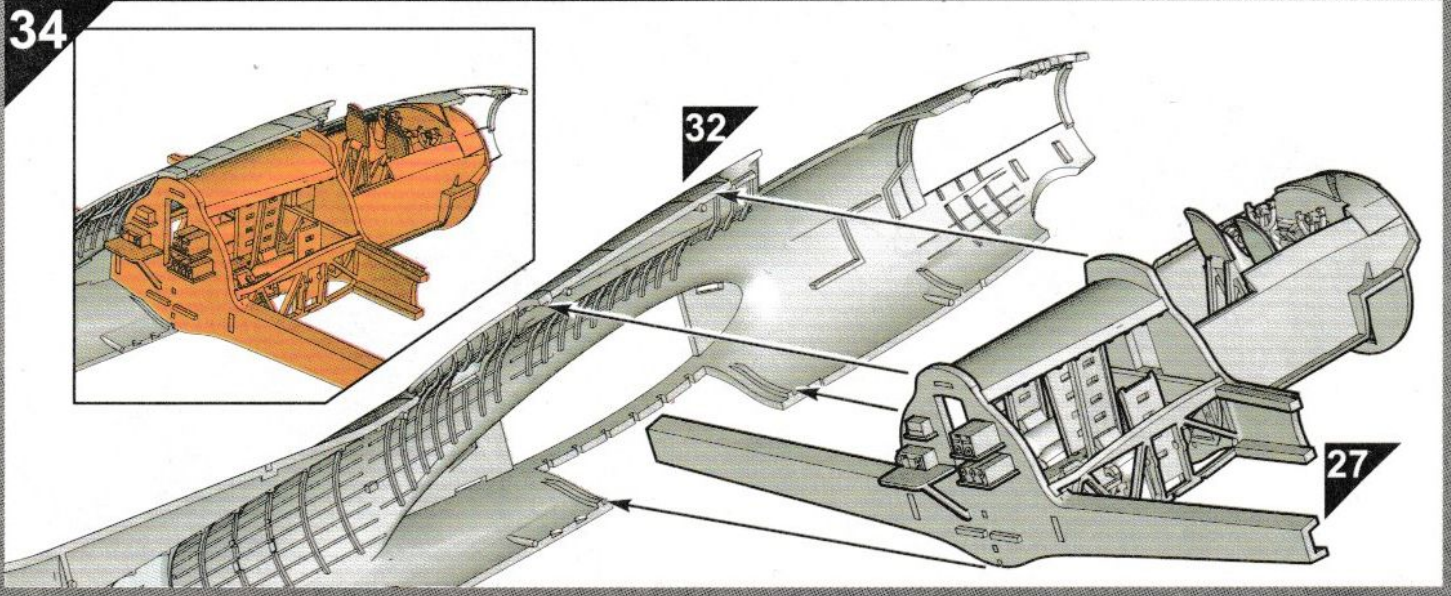
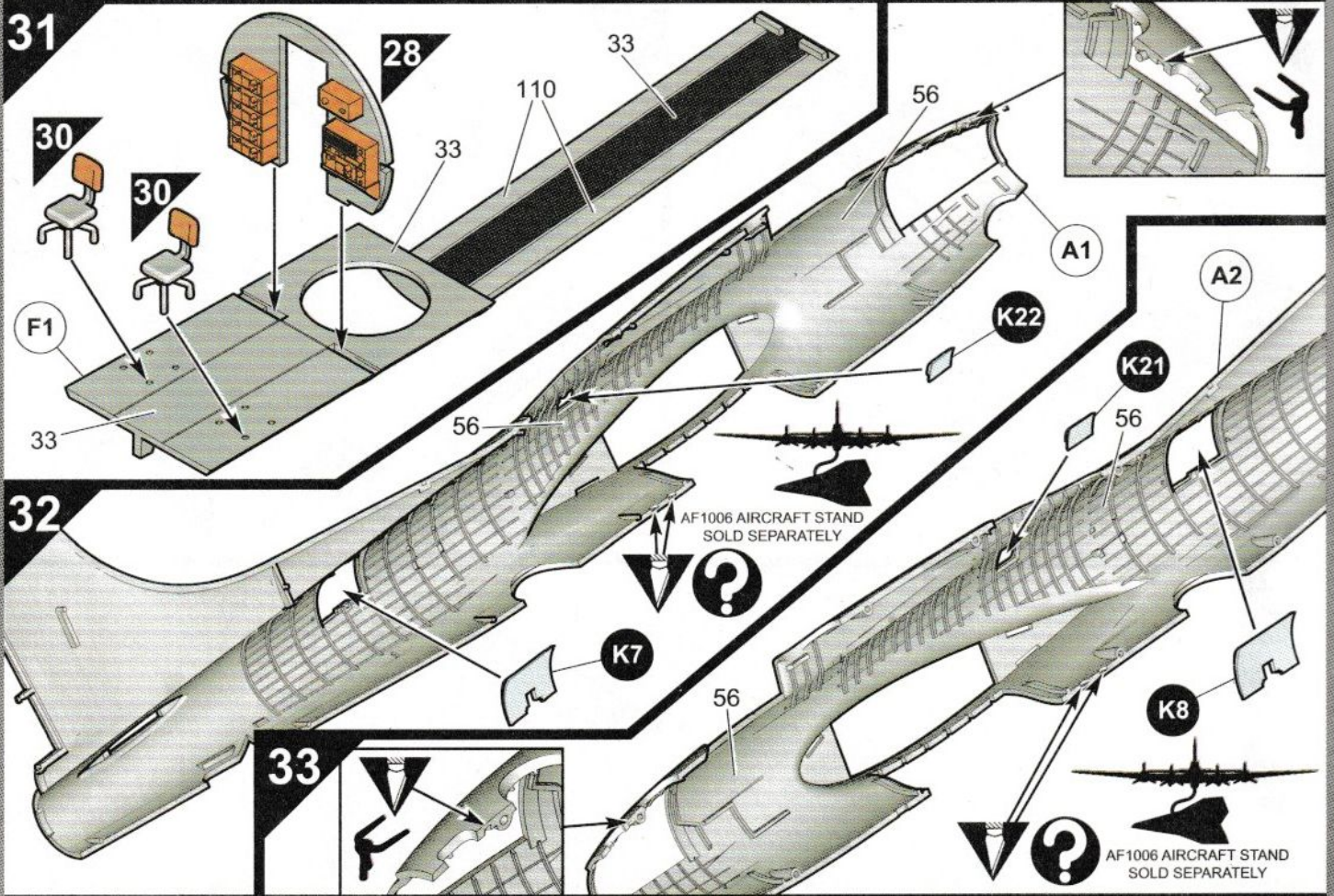
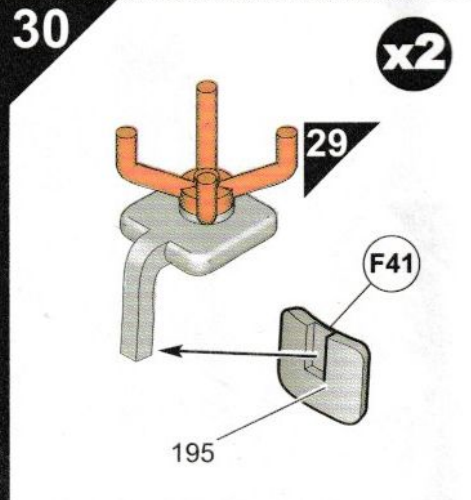
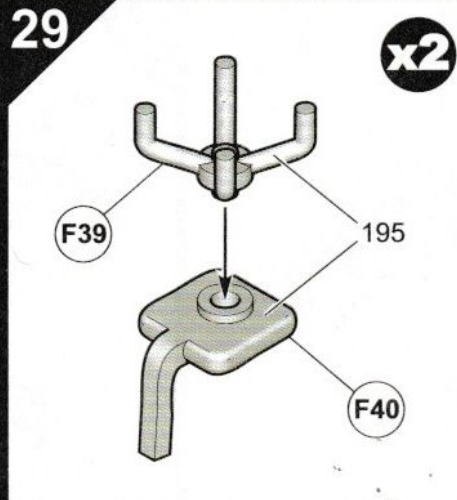
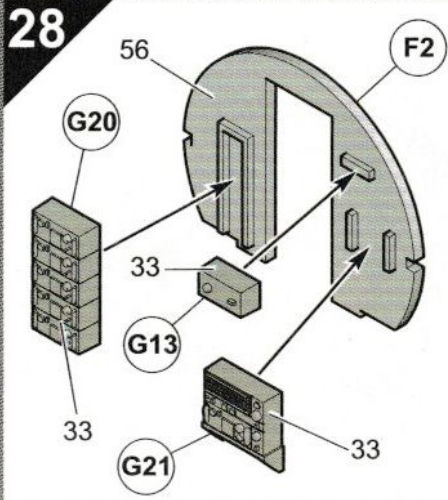

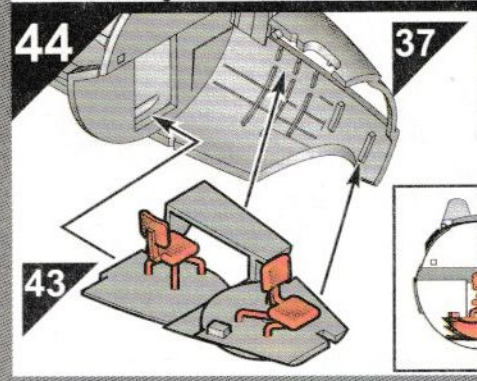
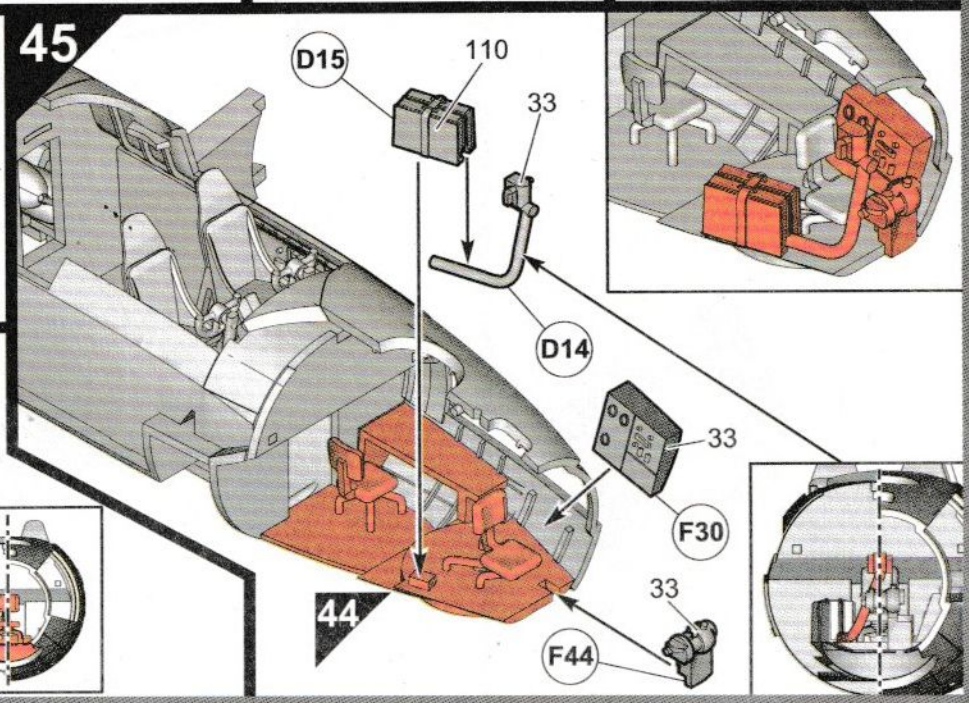
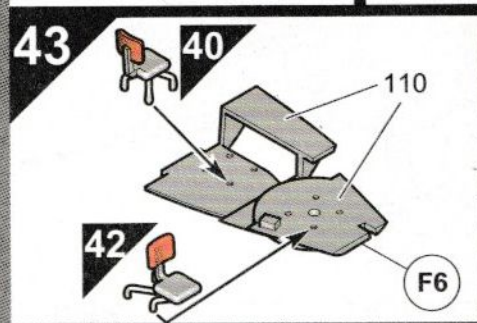
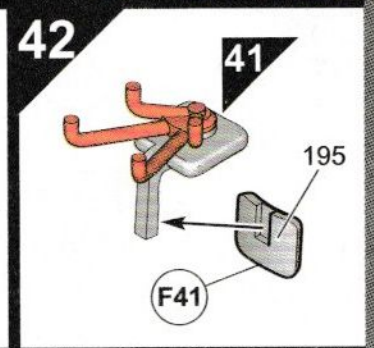
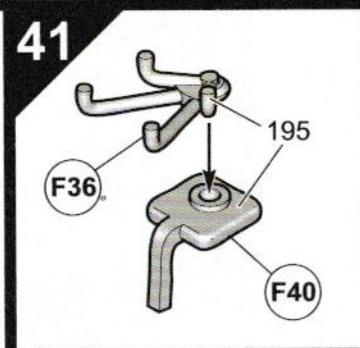
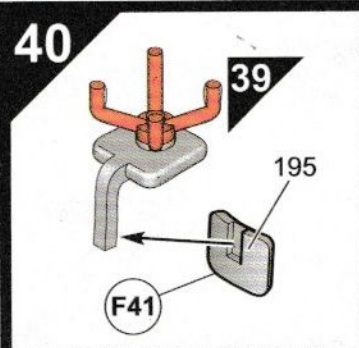
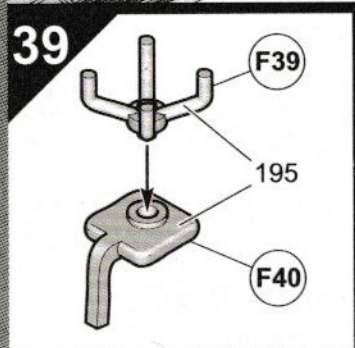
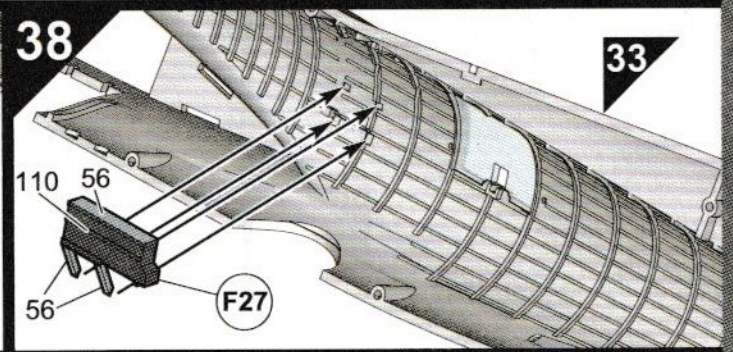
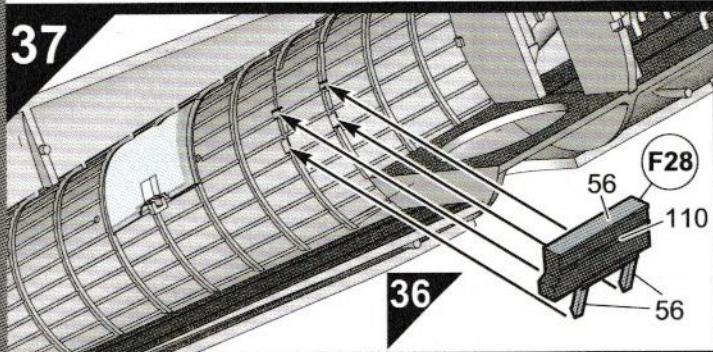
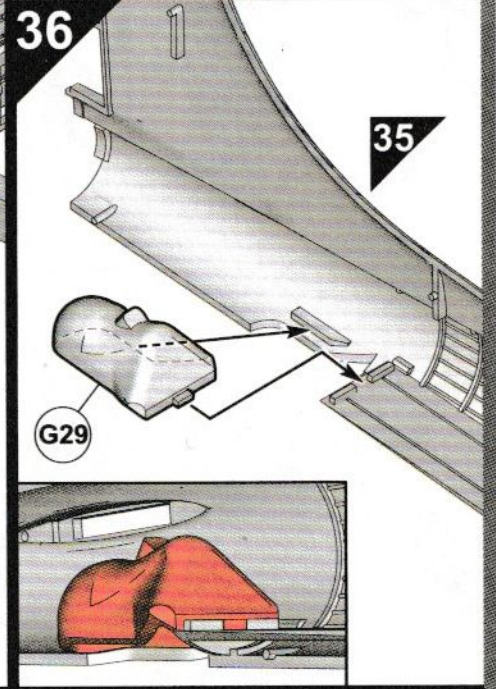
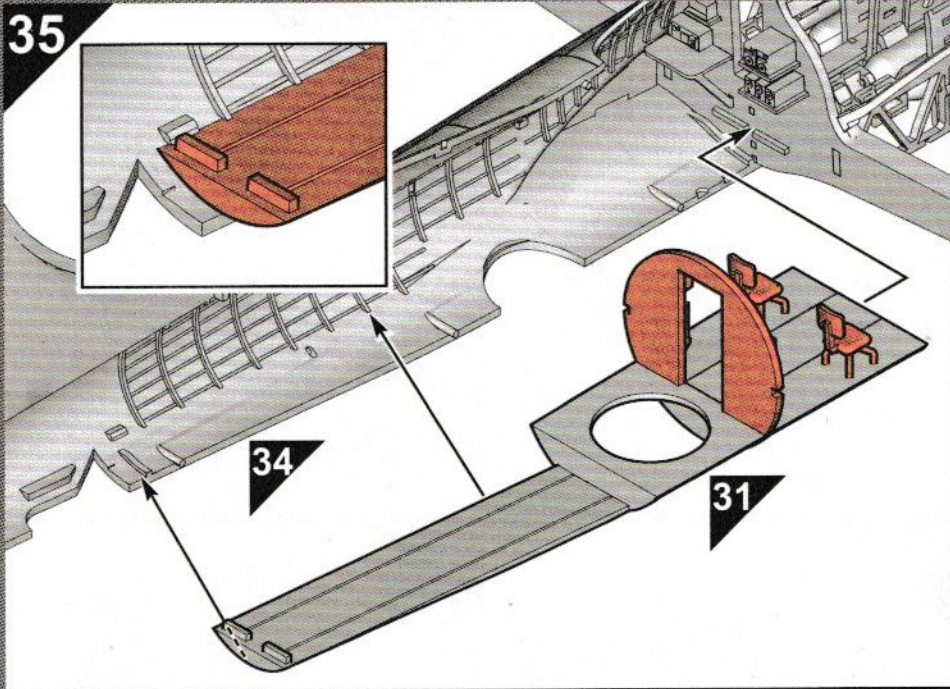

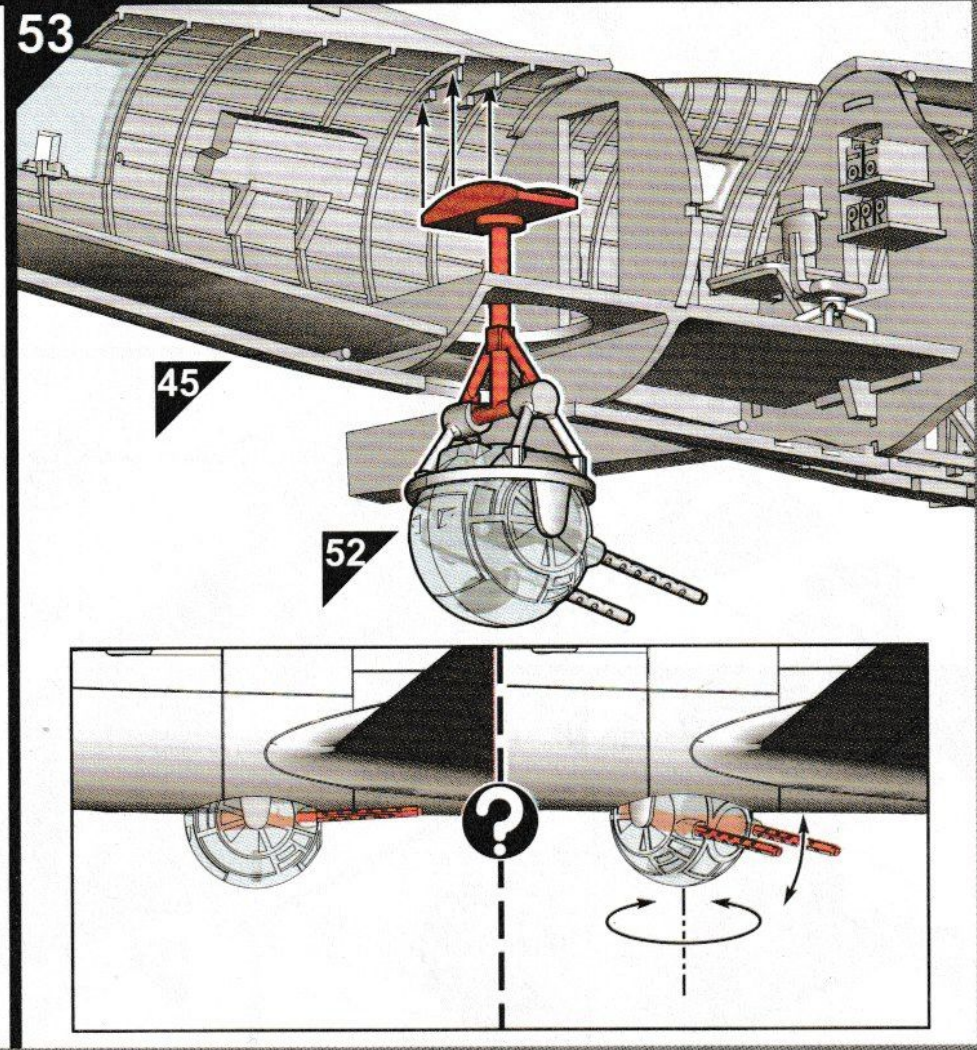
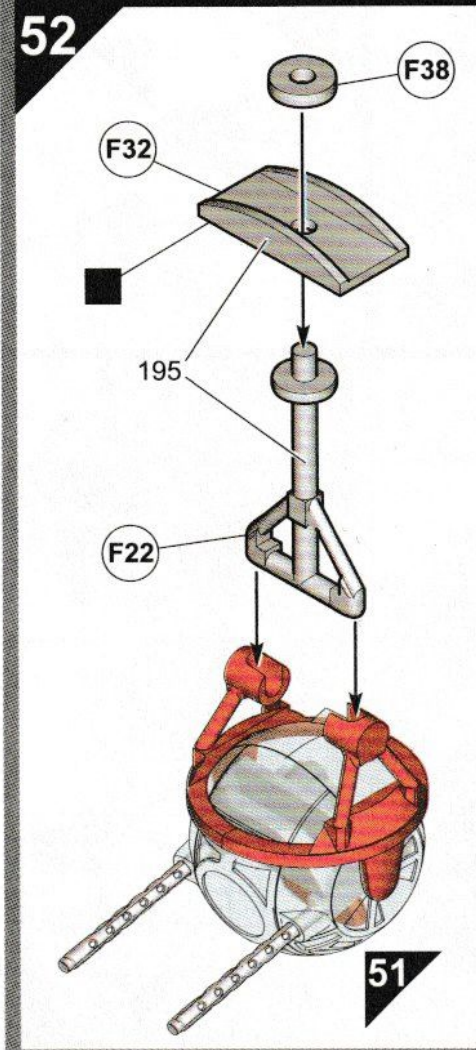
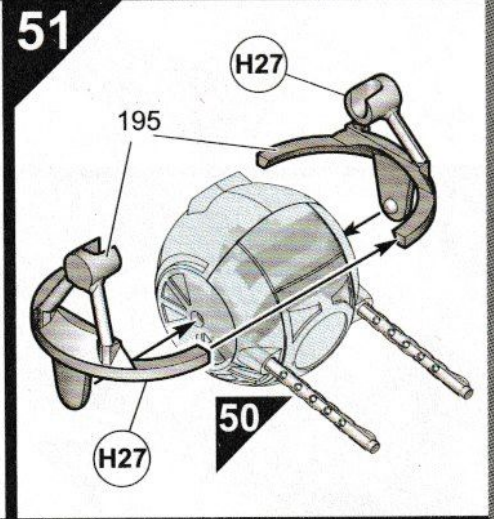
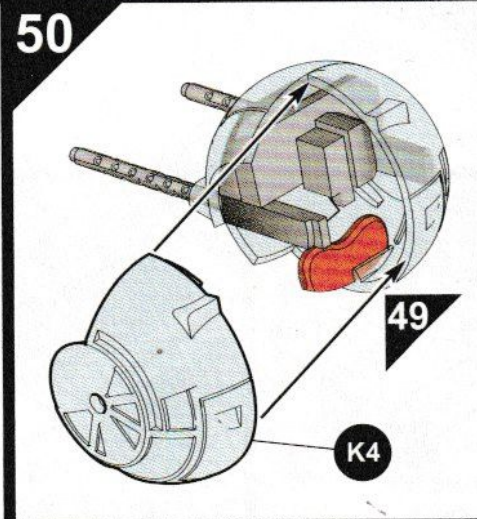
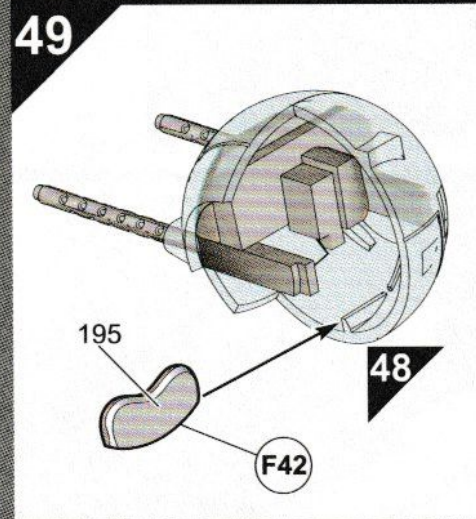
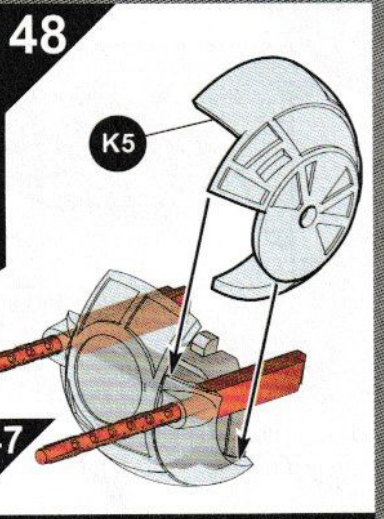
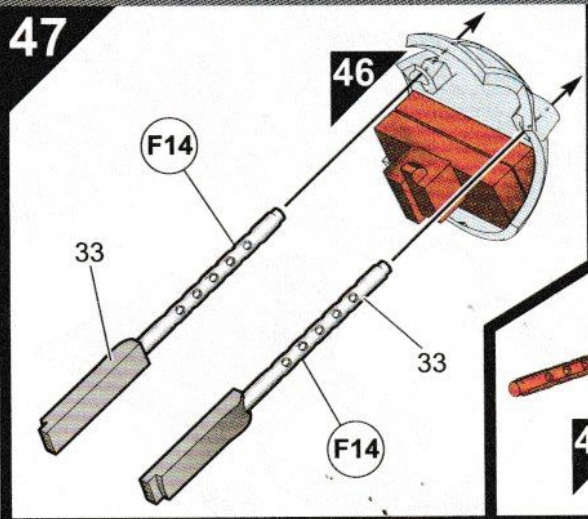
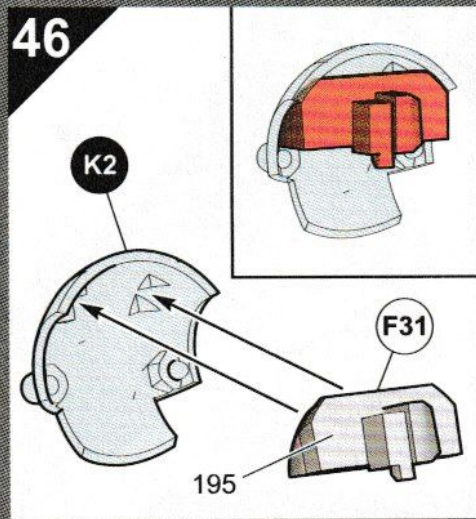

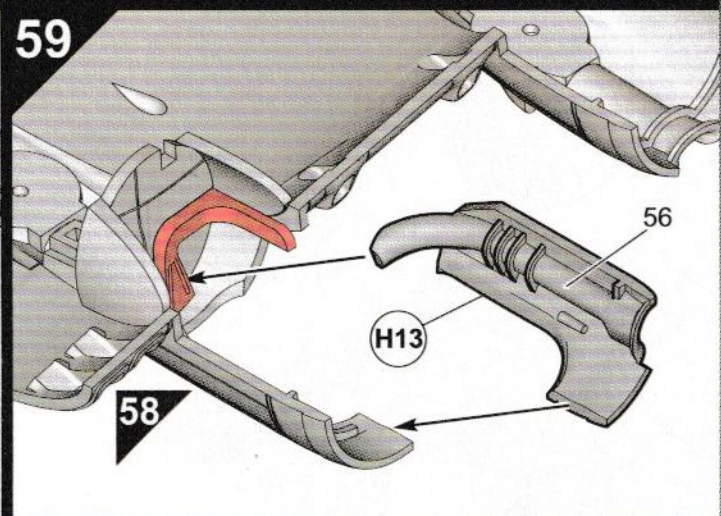
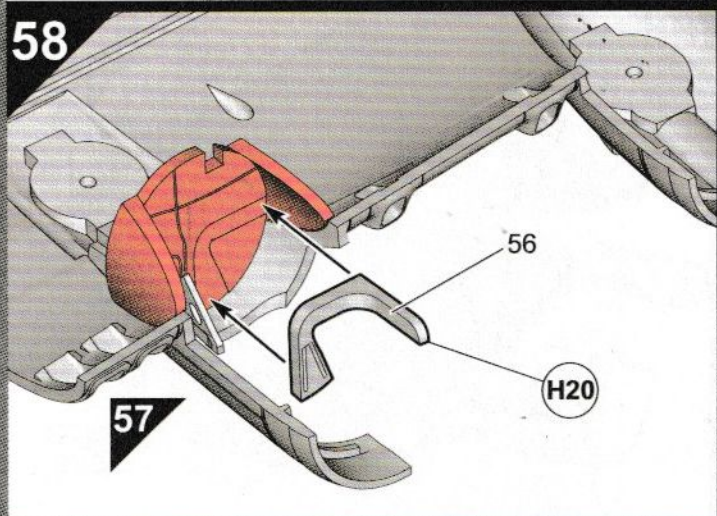
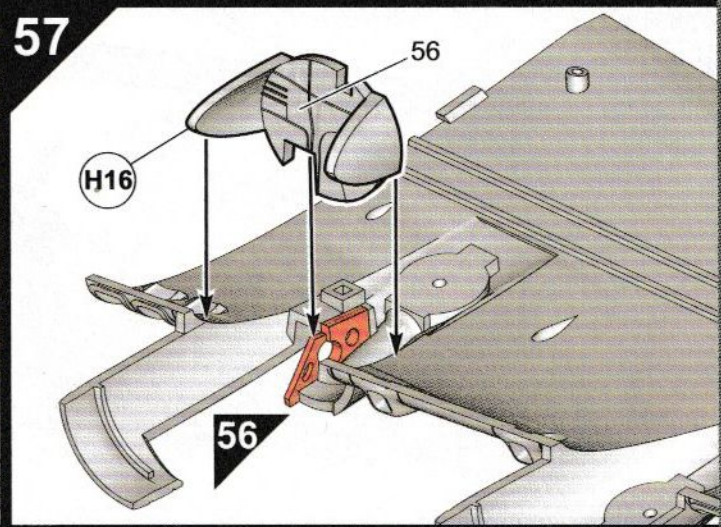
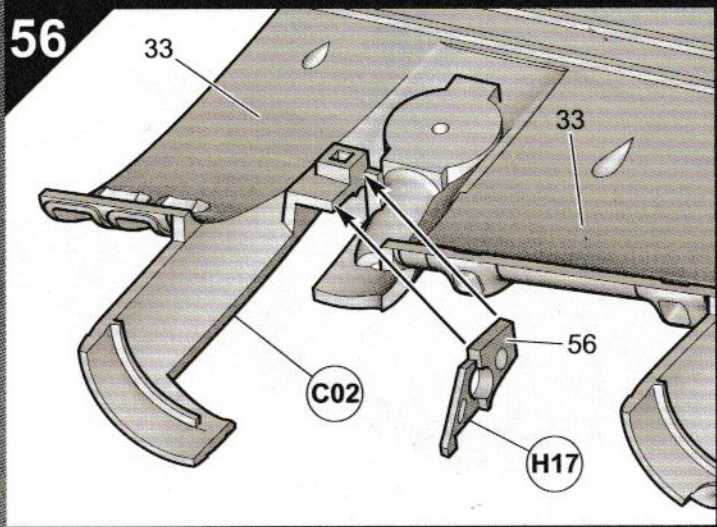
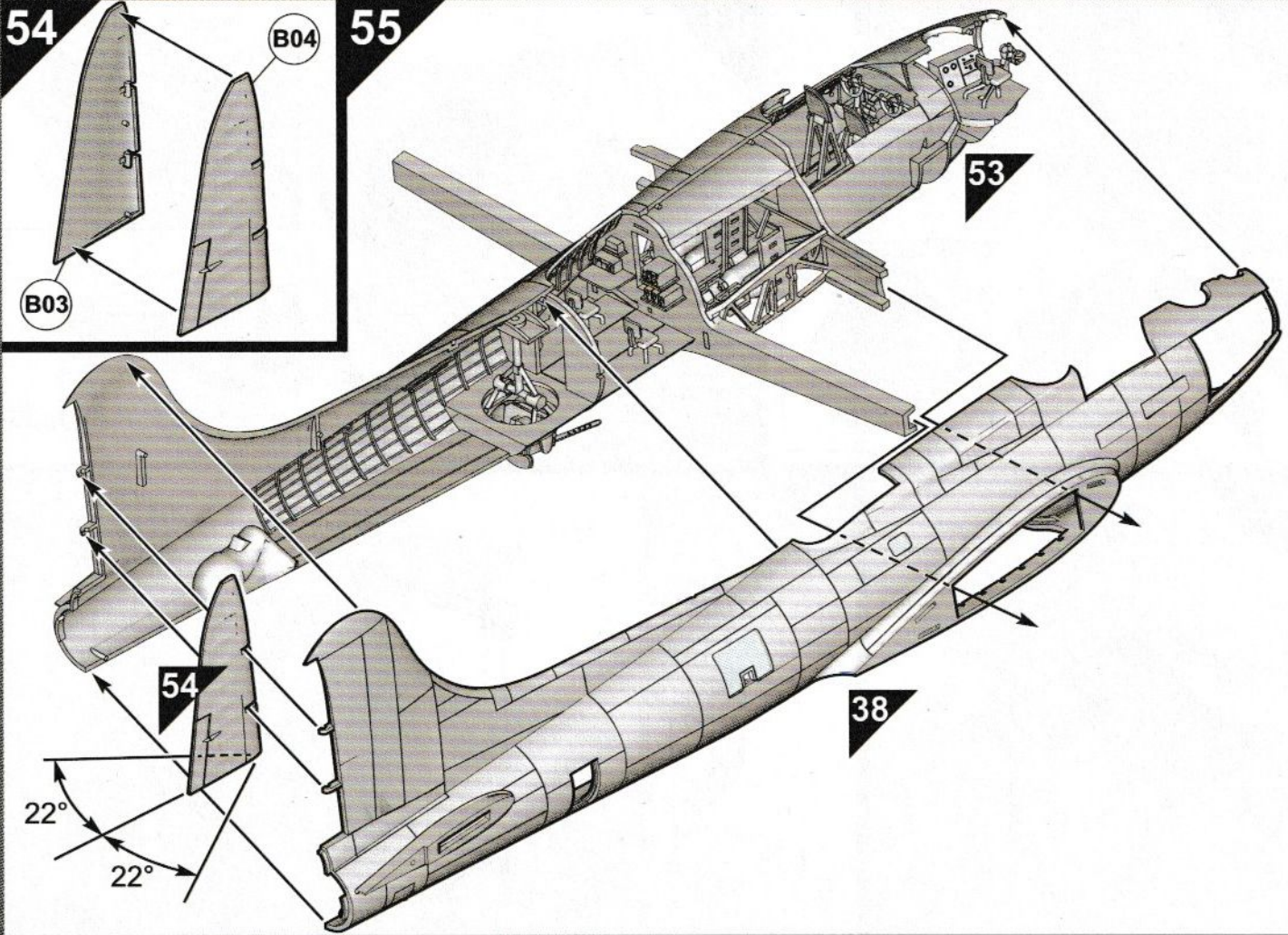

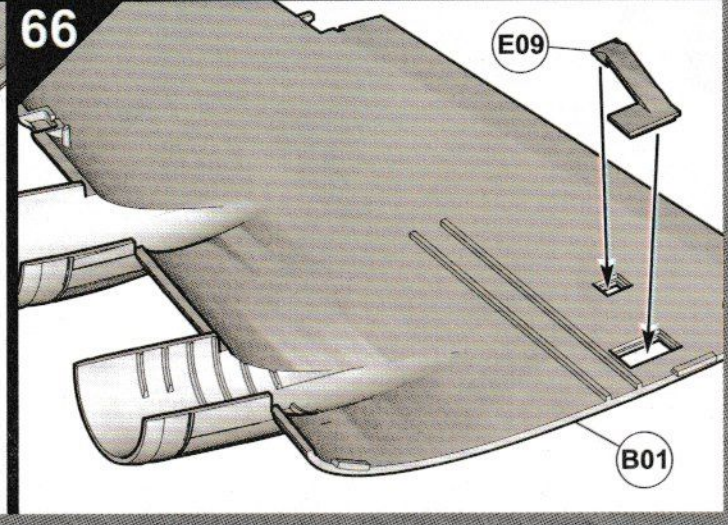
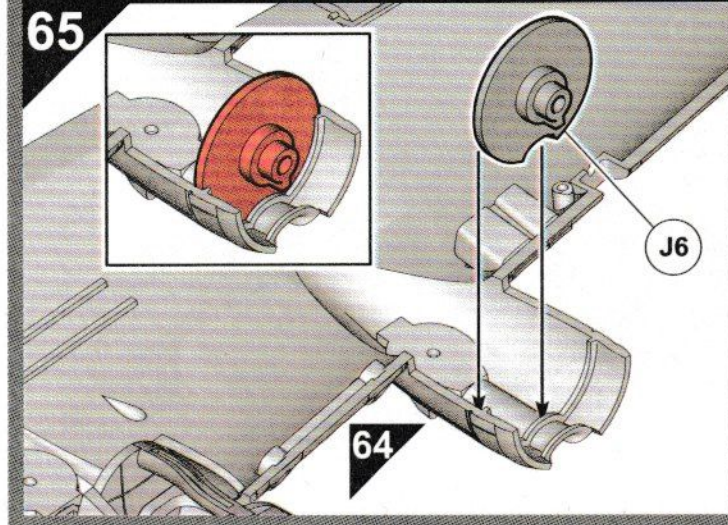
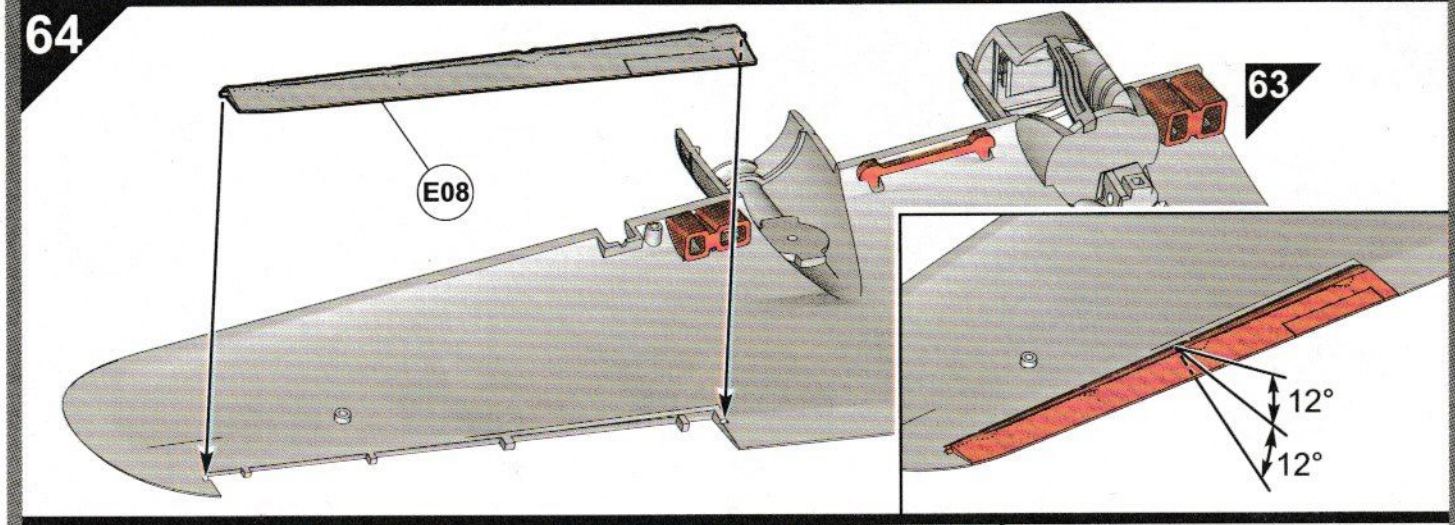
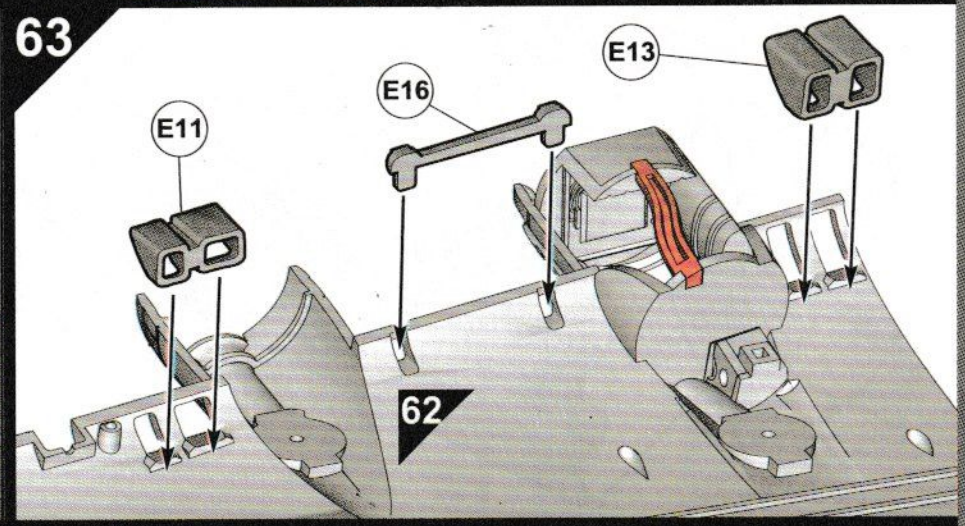
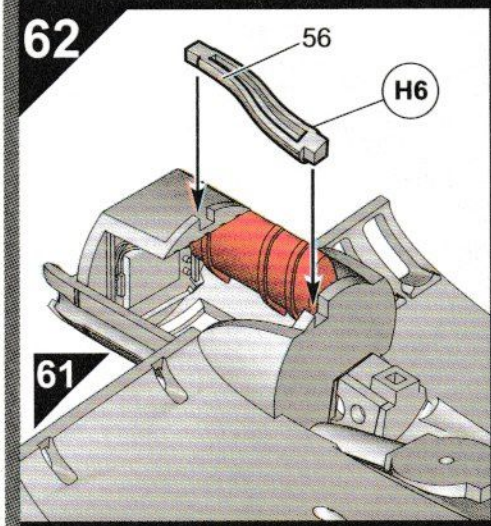
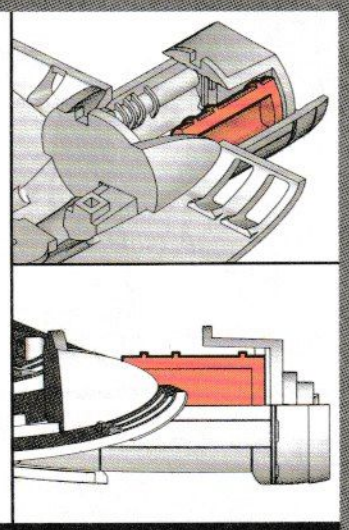
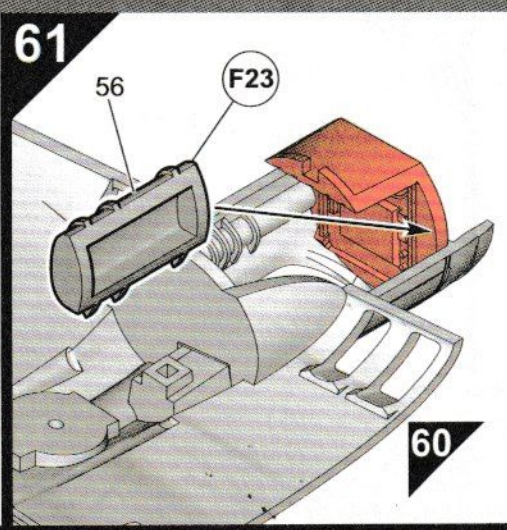
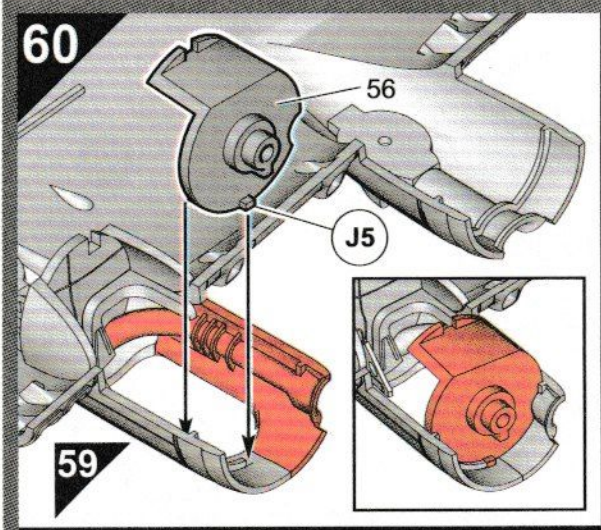

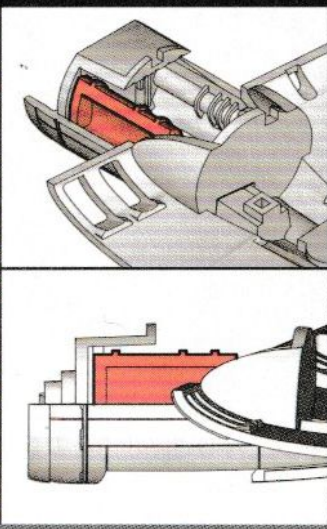
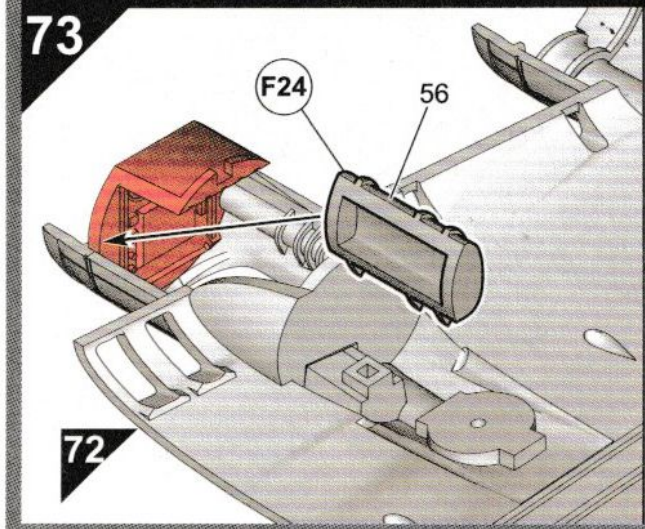
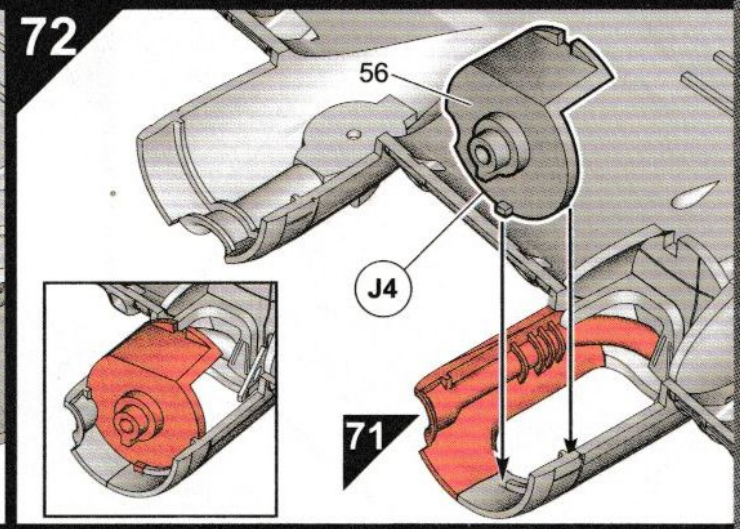
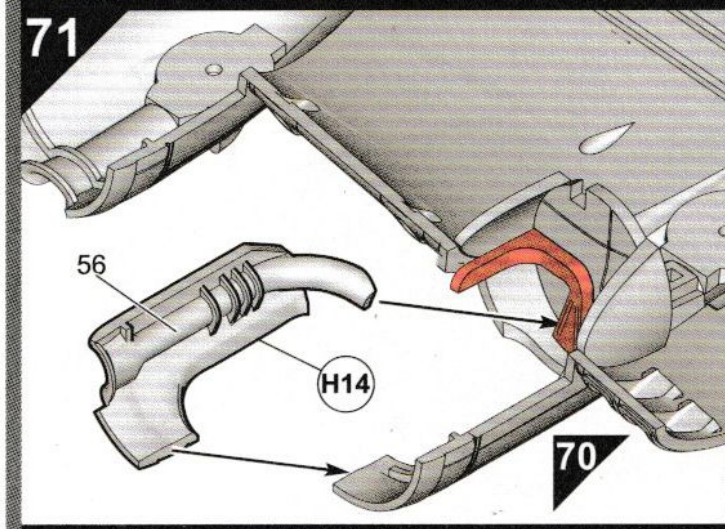
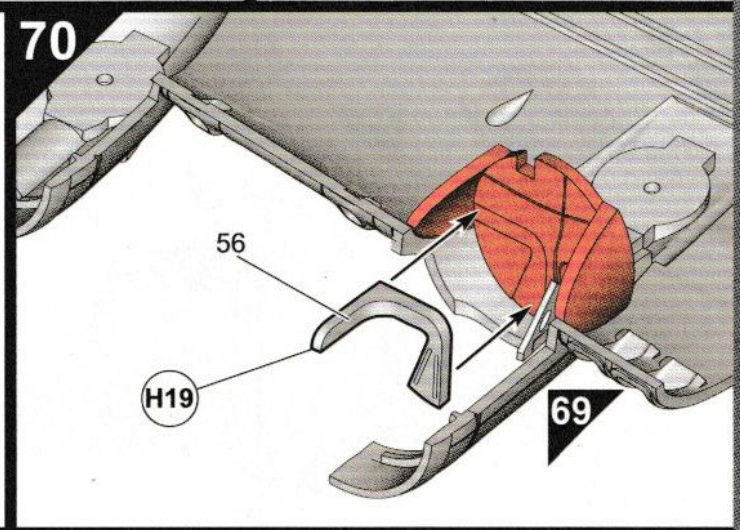
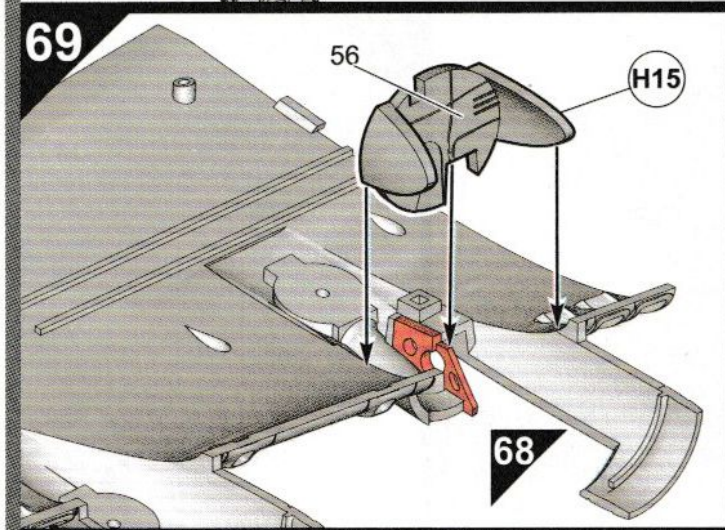
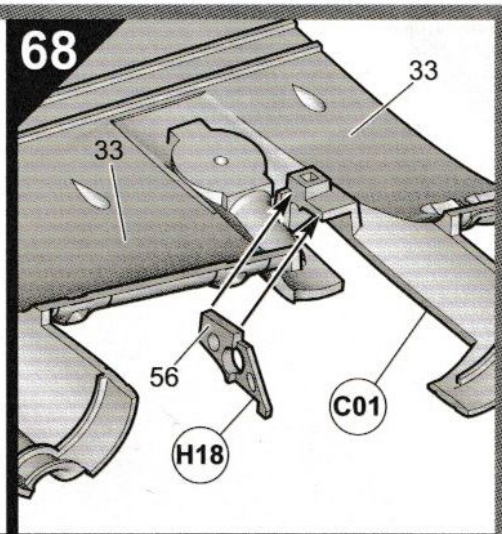
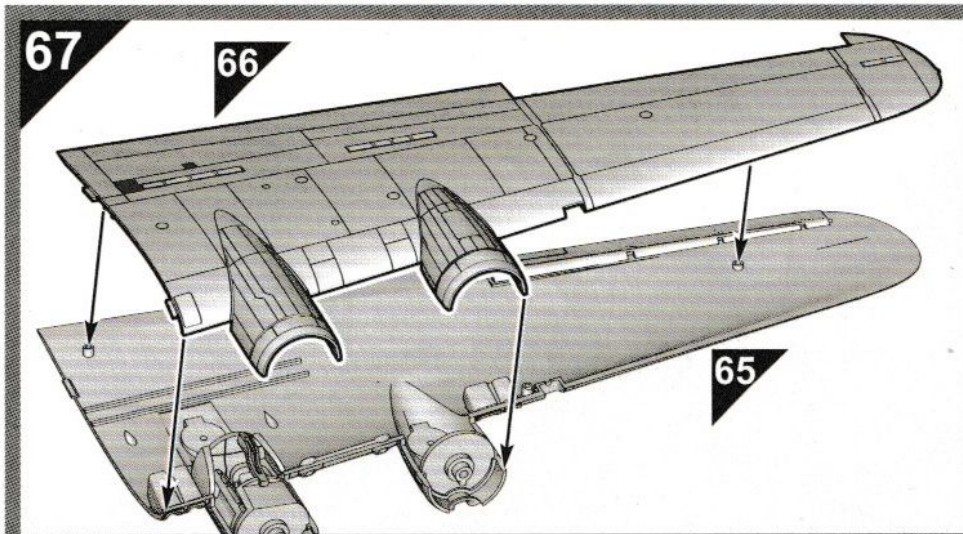

75

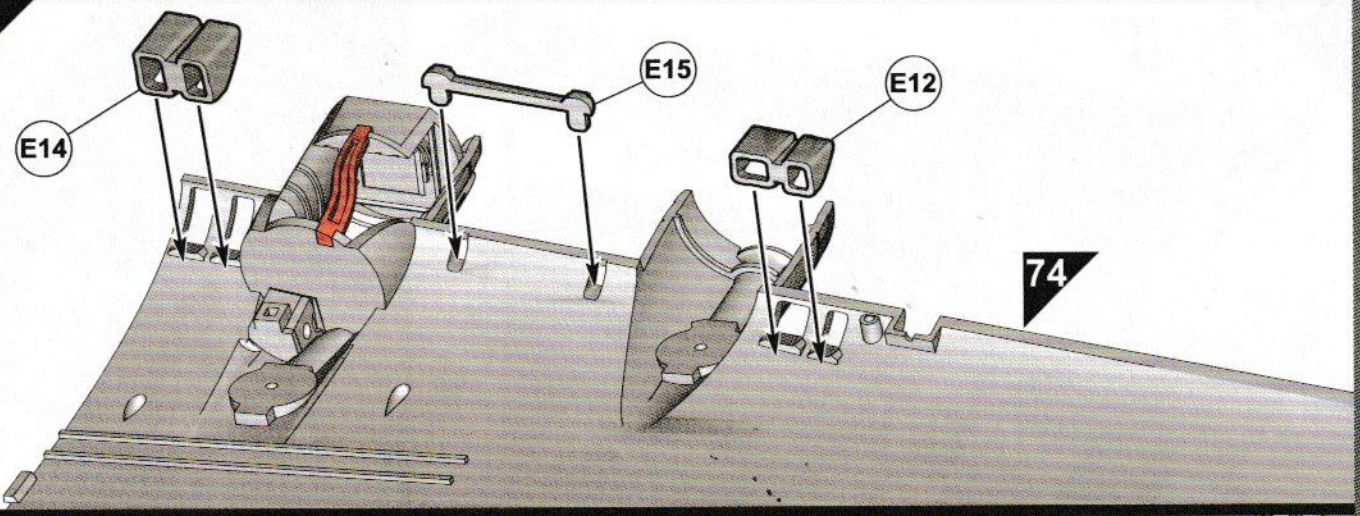

76

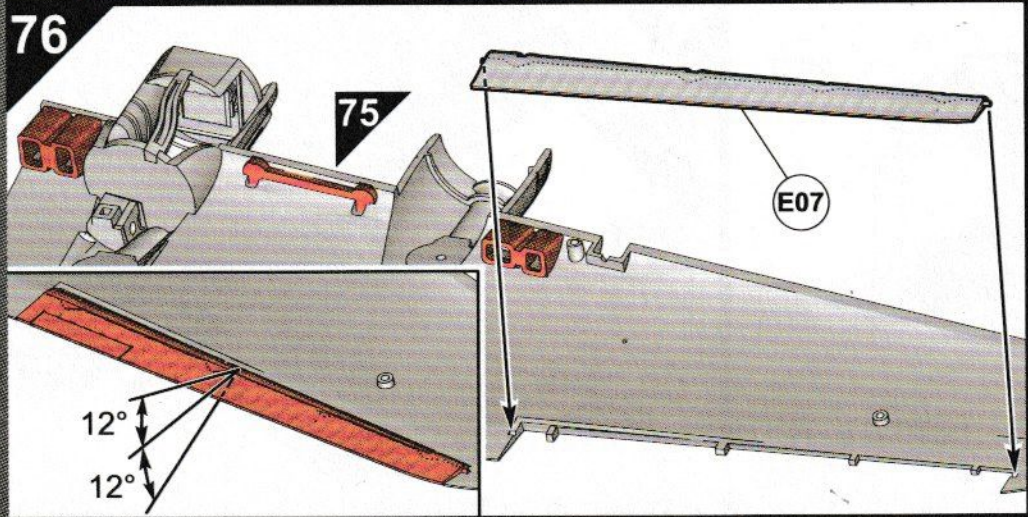

77

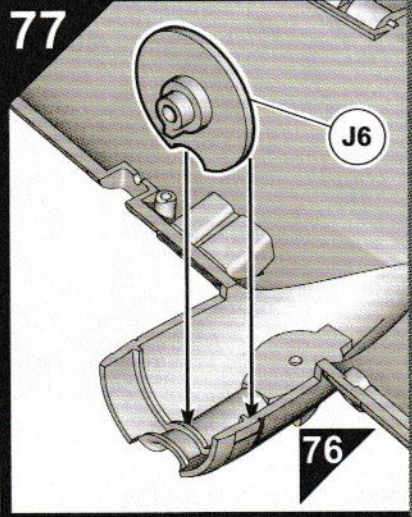

78

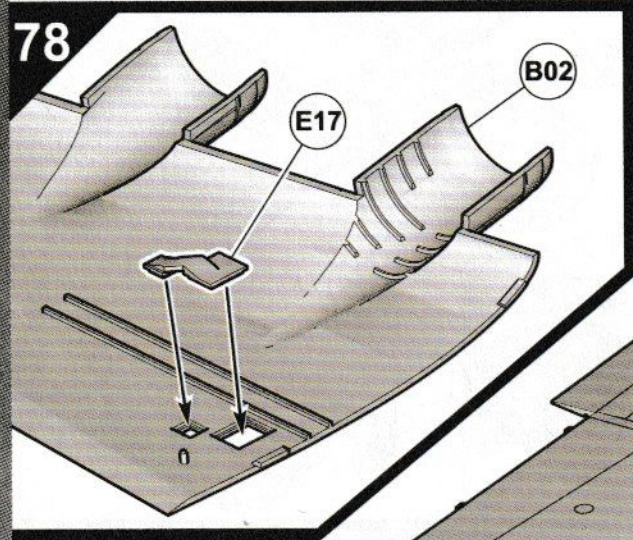

79

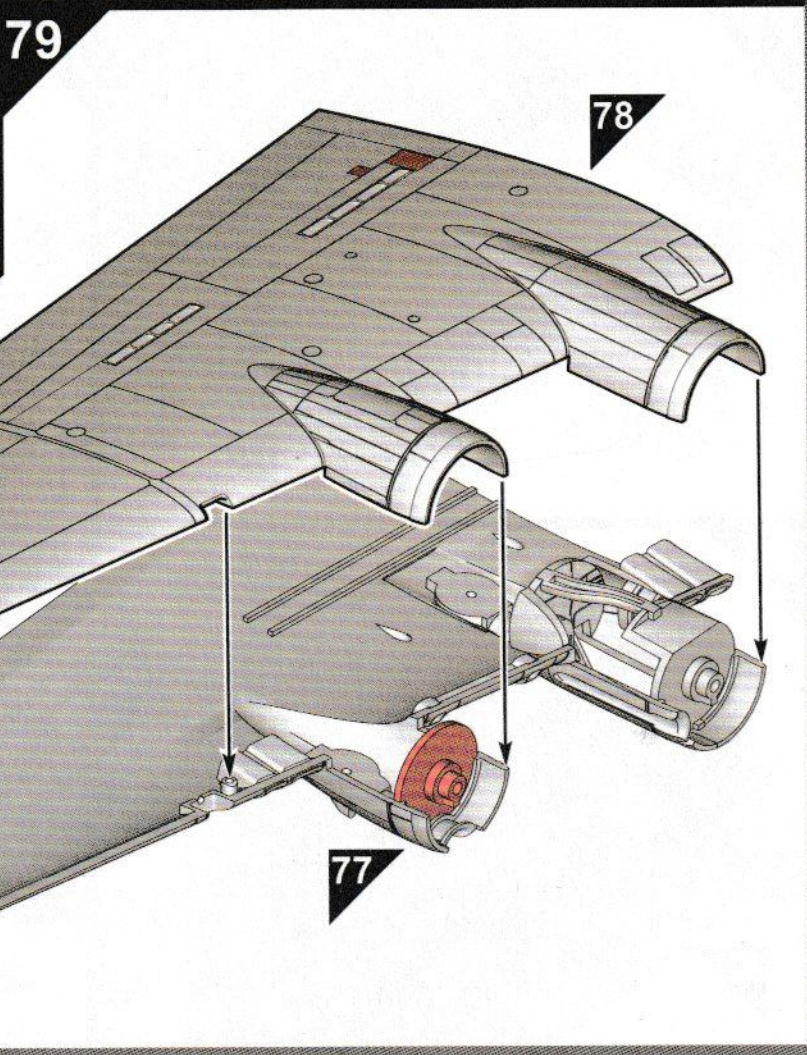

80

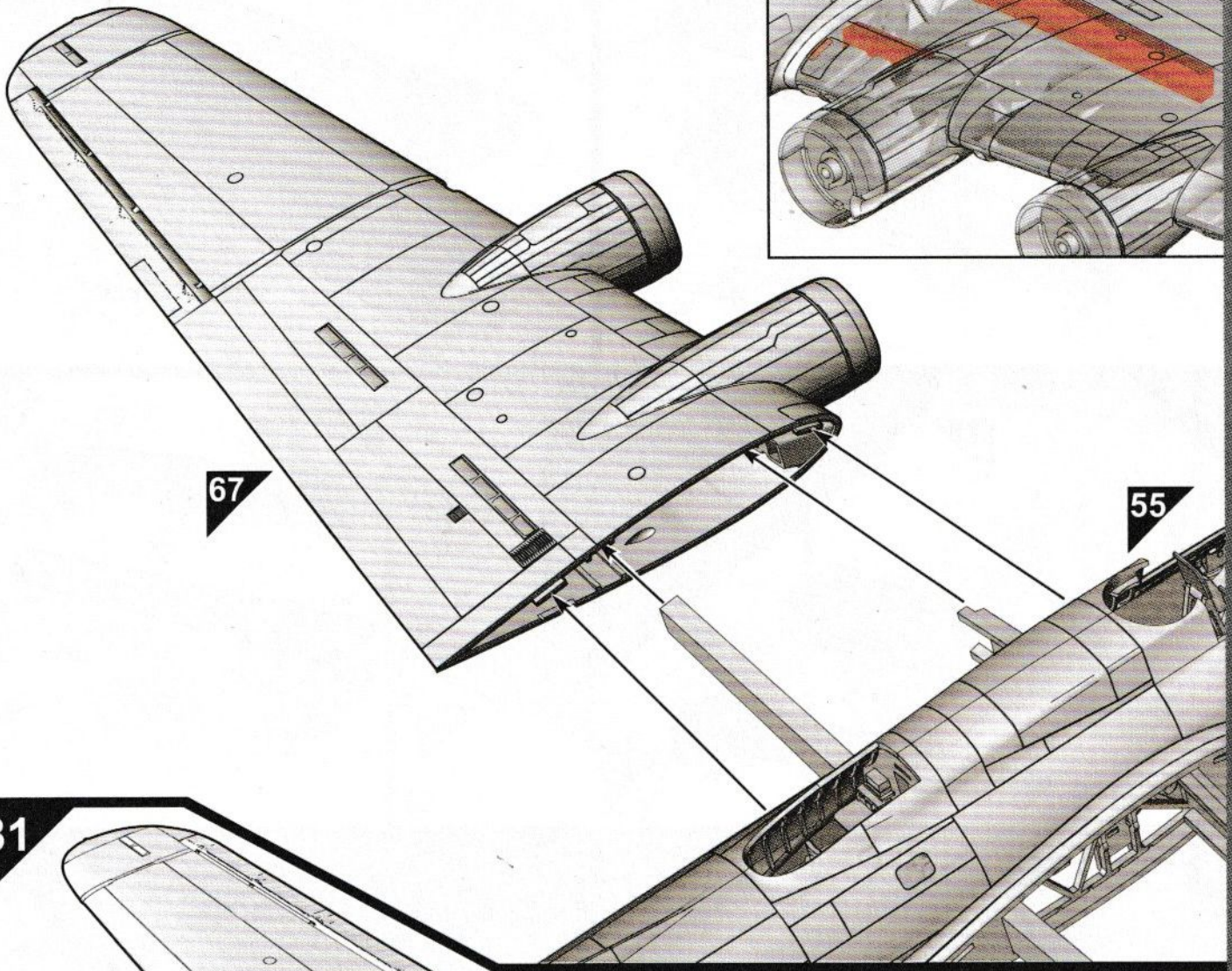
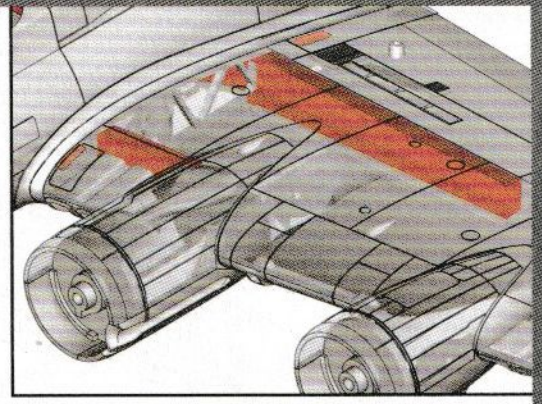

81

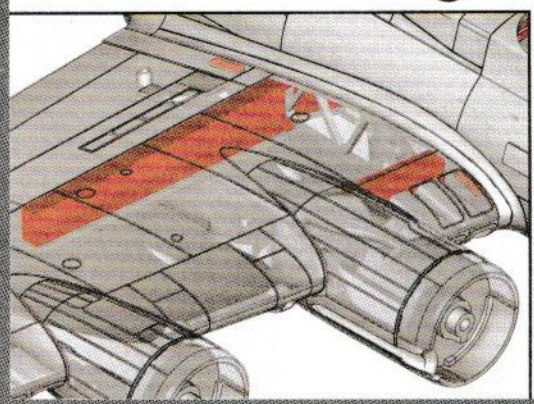
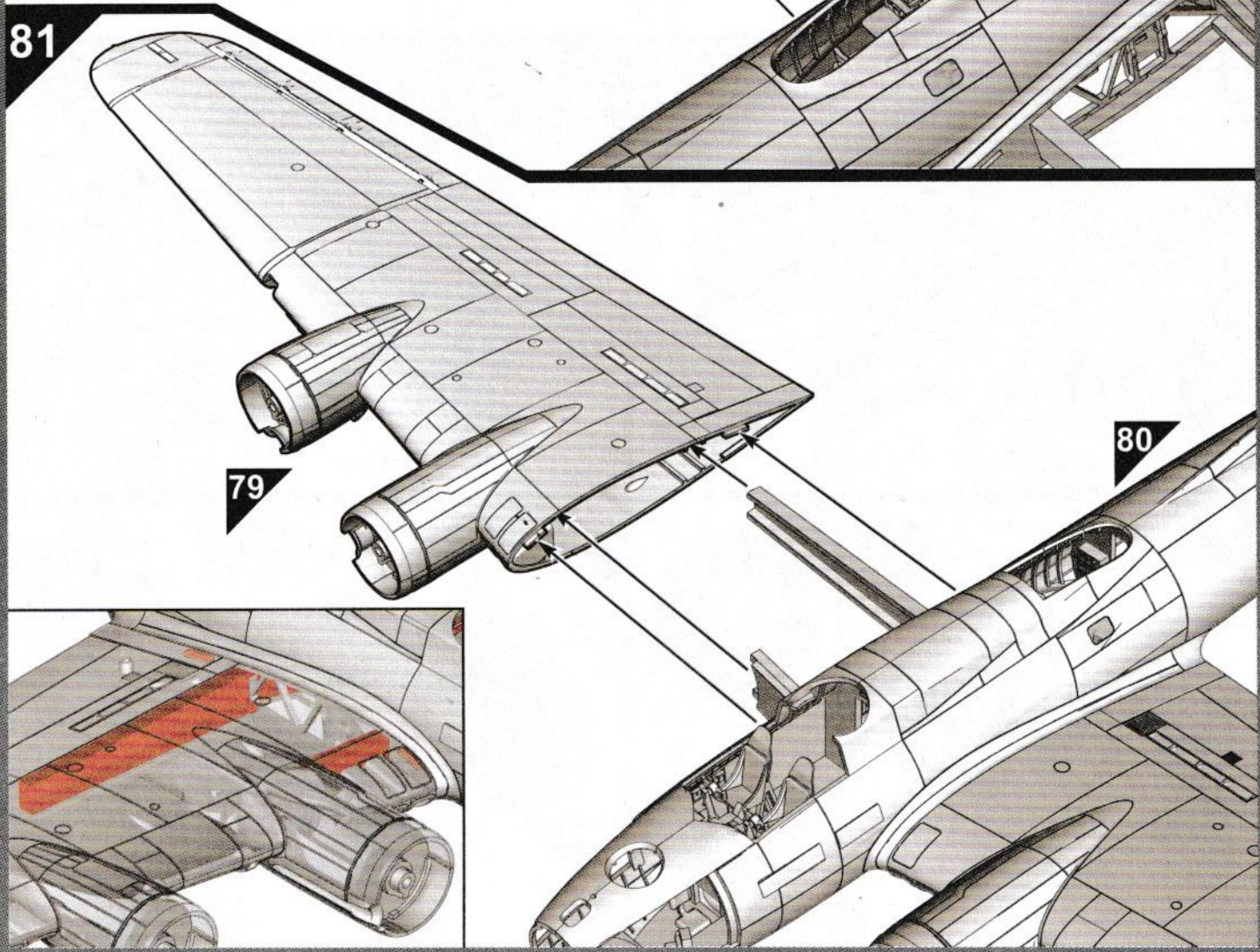

82

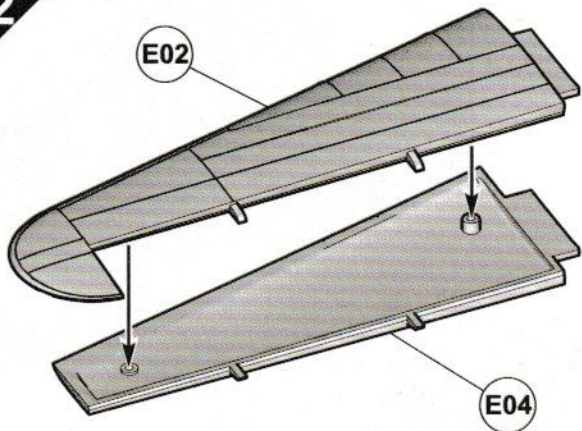

83

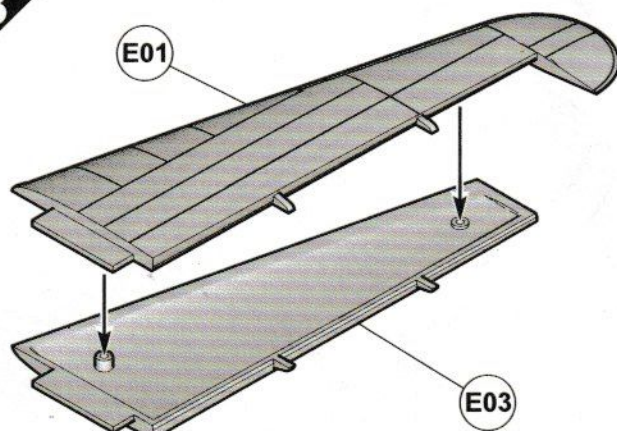

84

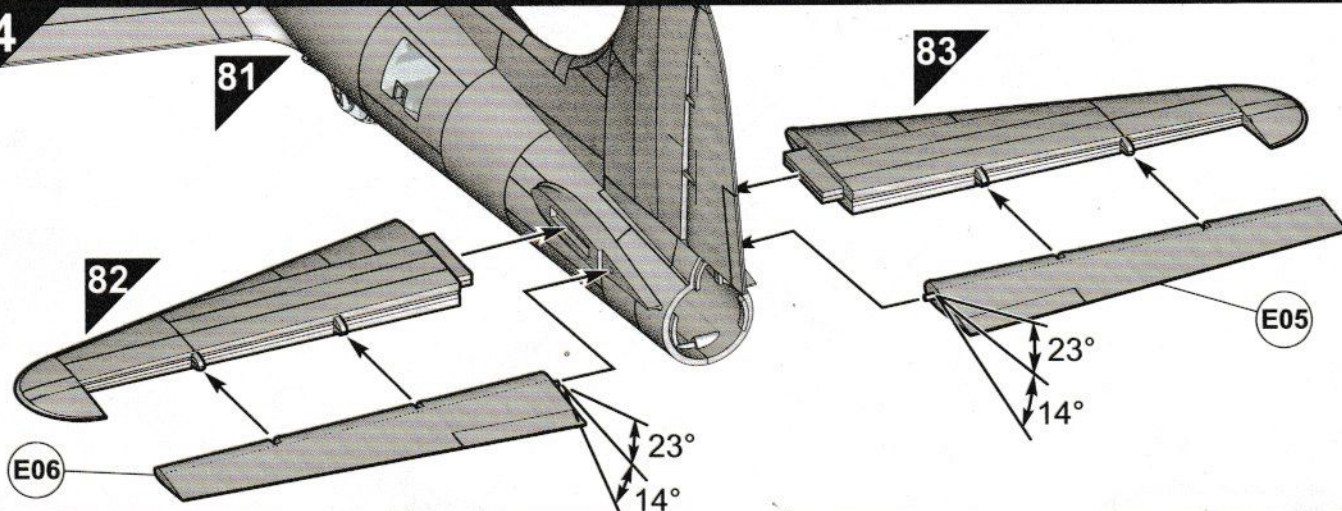

85

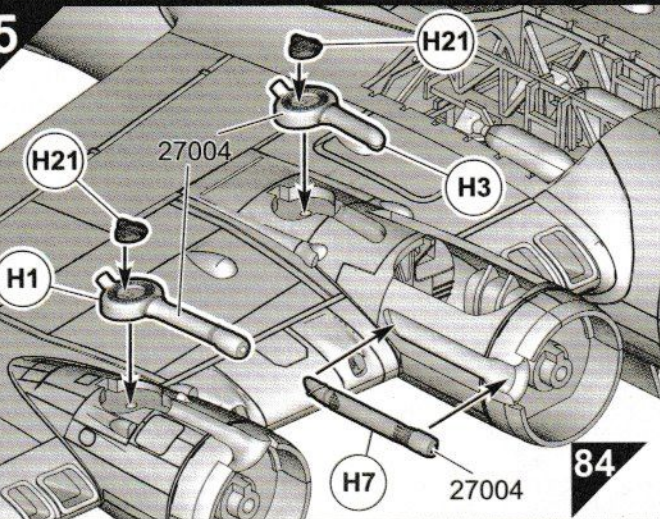

86

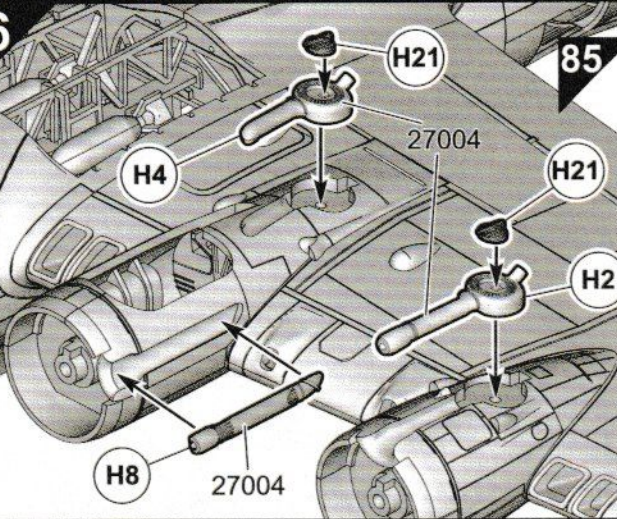

87

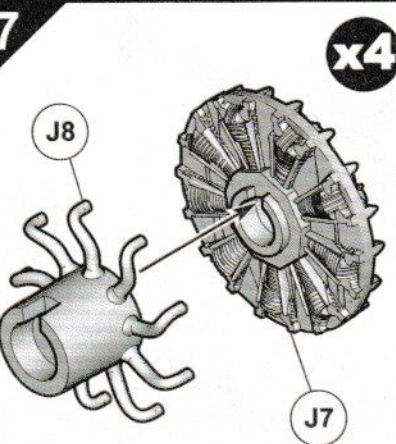

x4

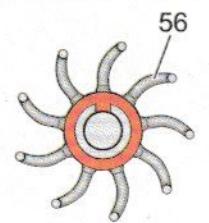
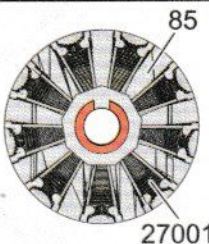

88

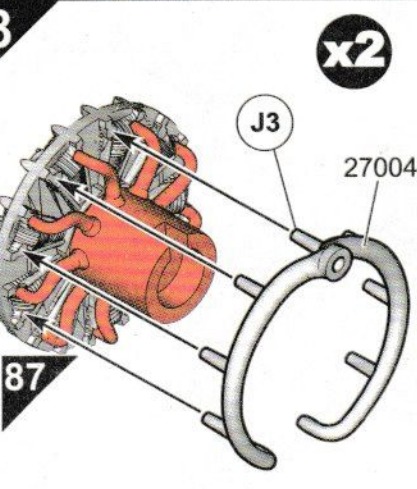

x2

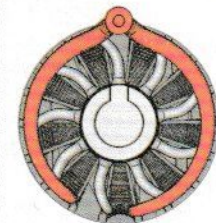
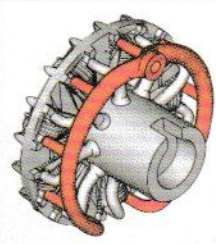

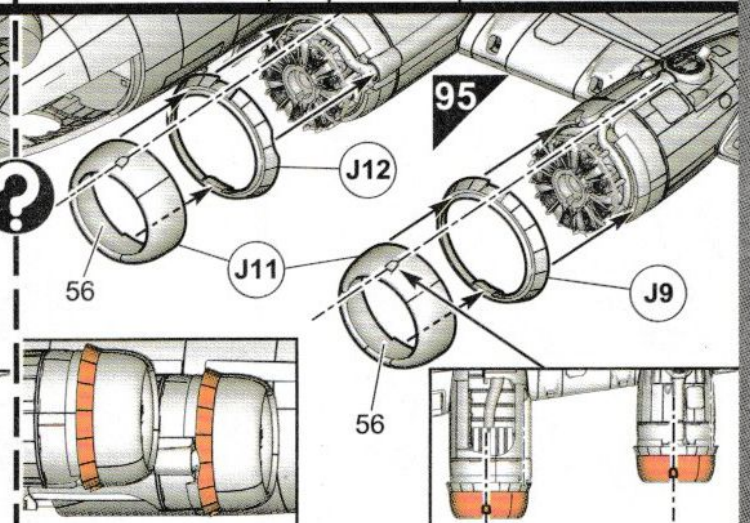
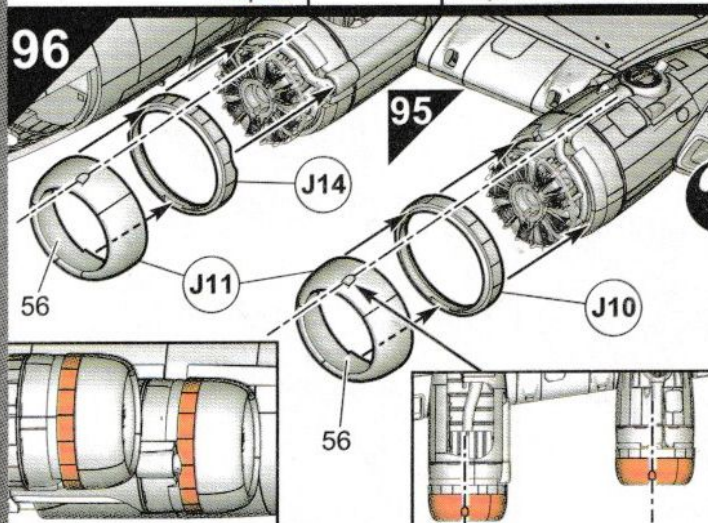
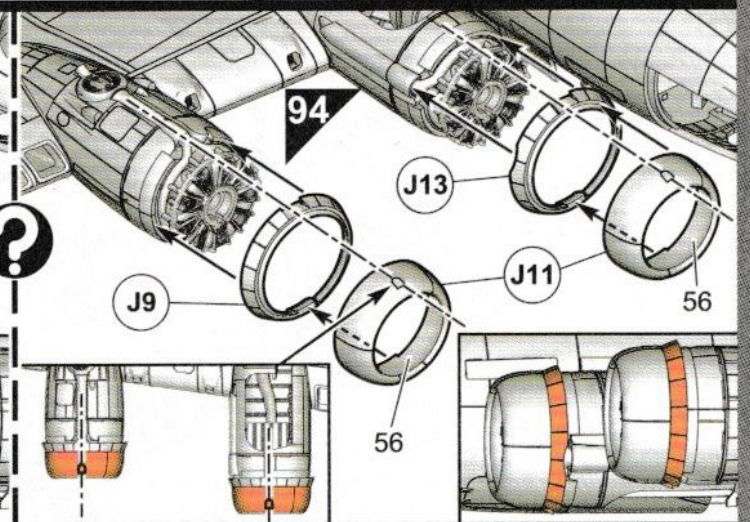
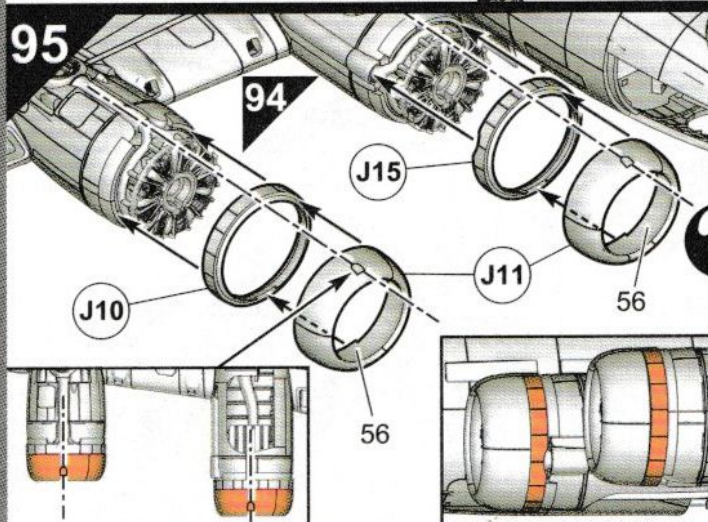
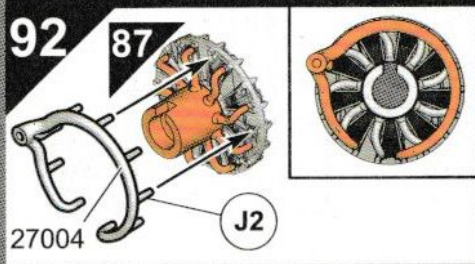
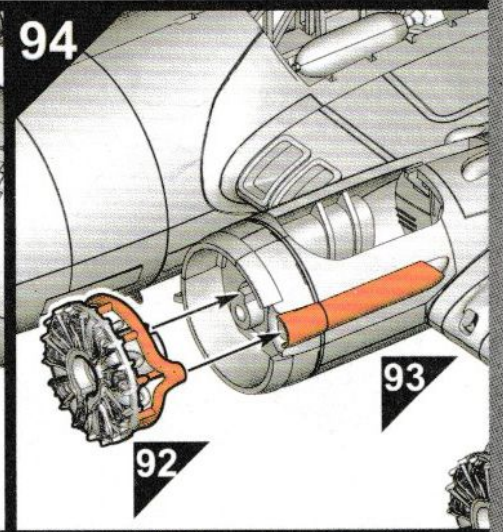
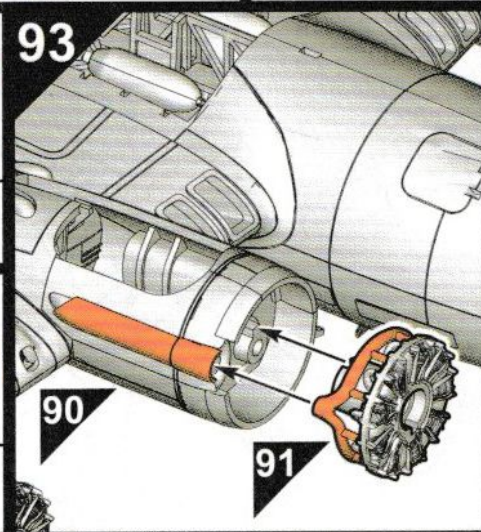
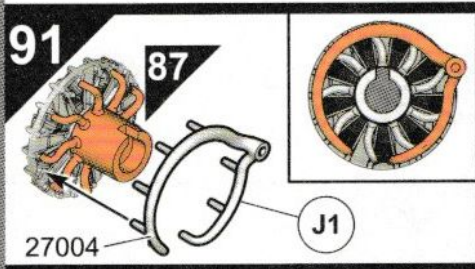
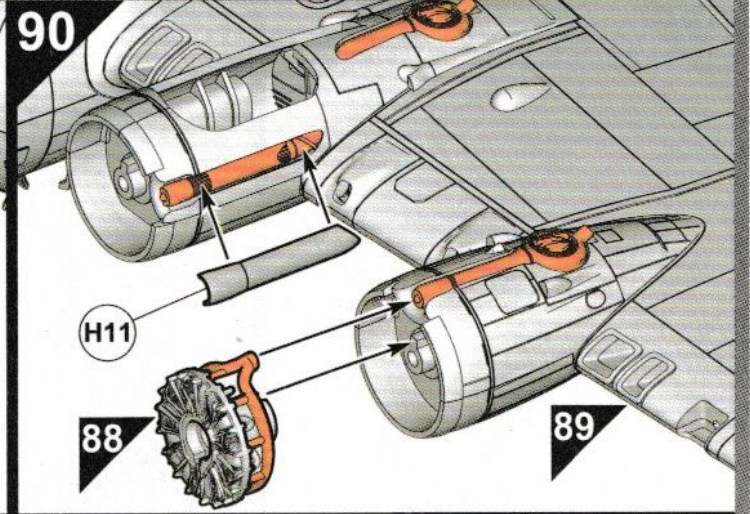
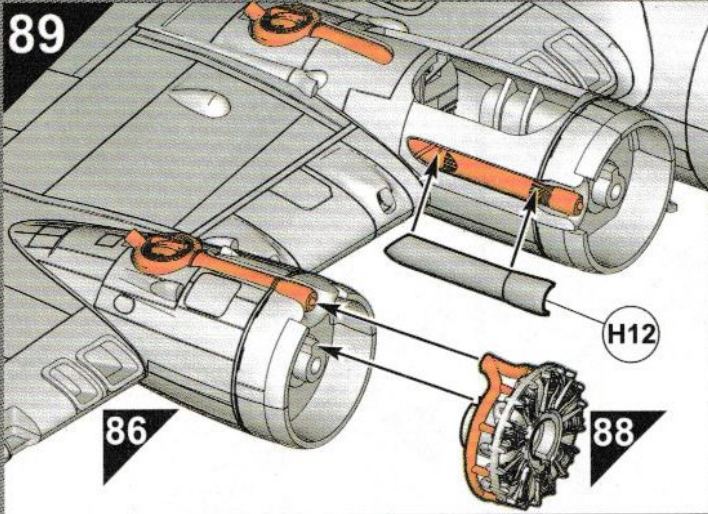

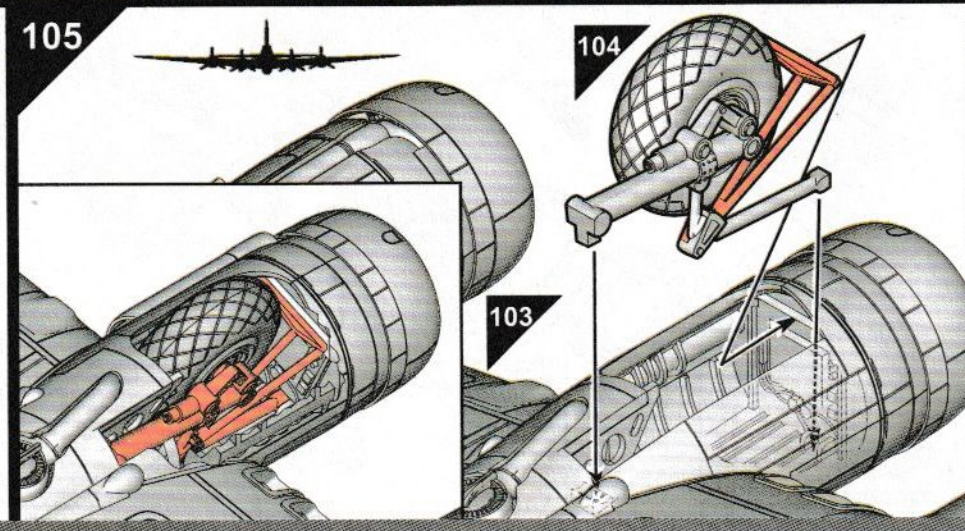
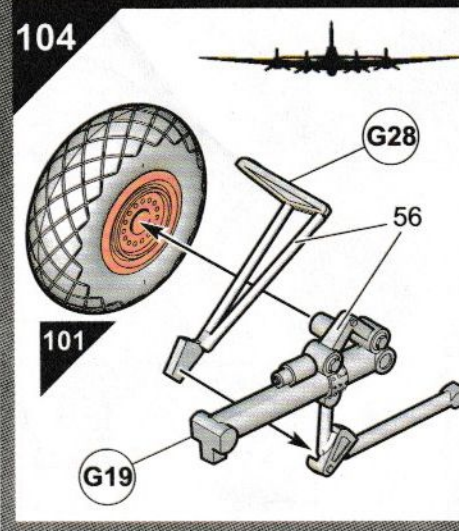
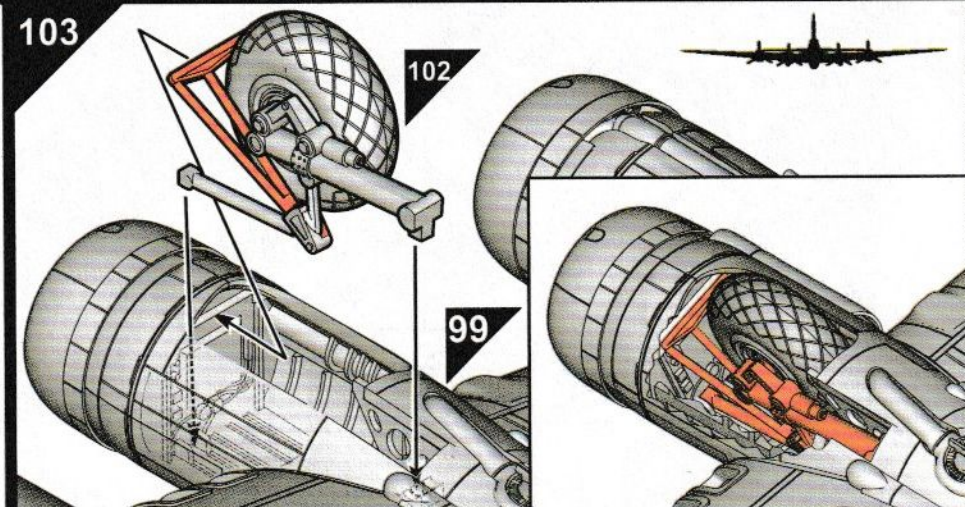
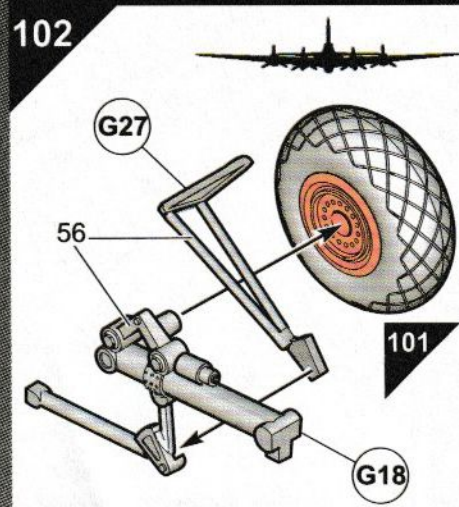
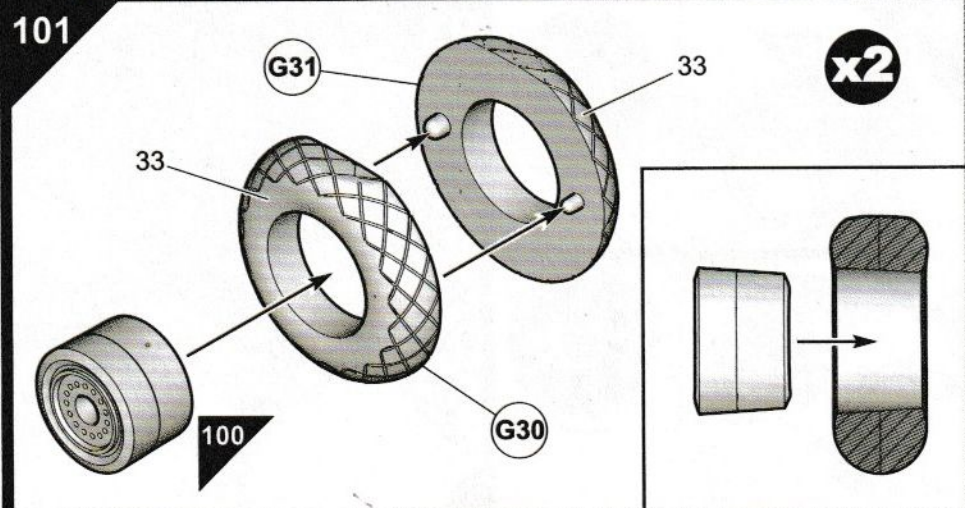
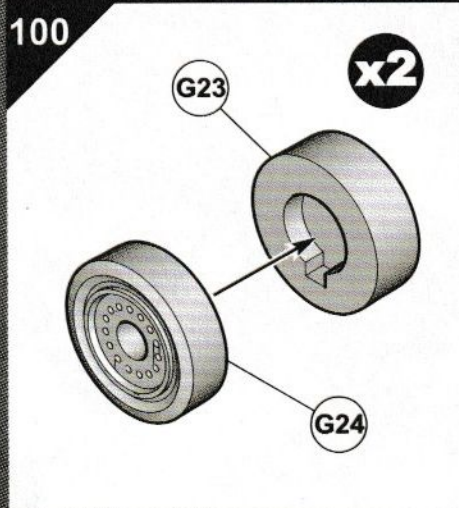
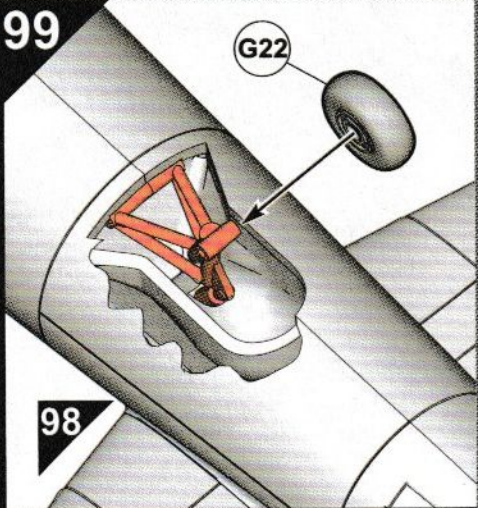
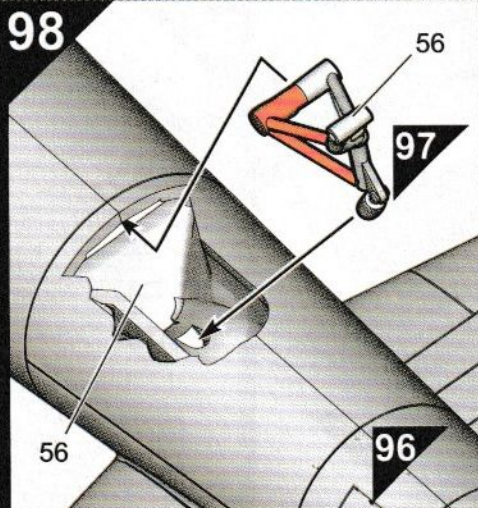
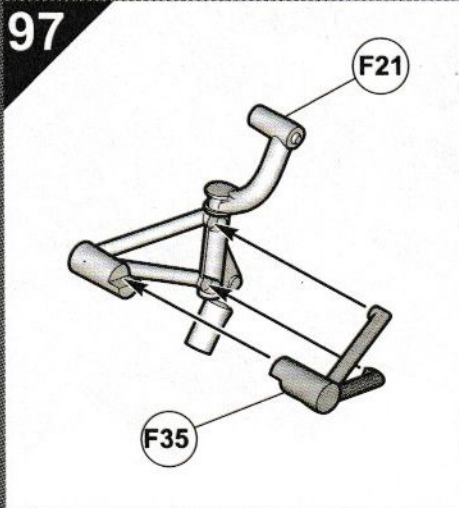

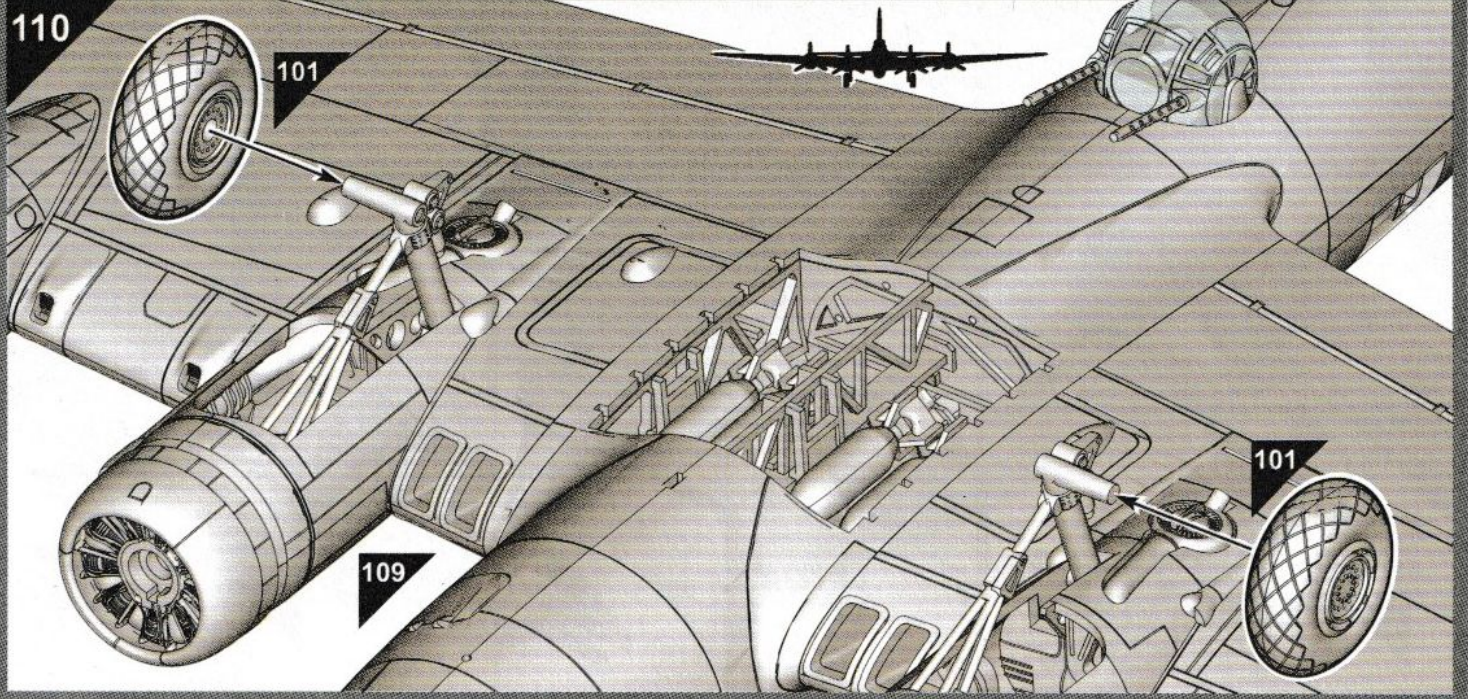
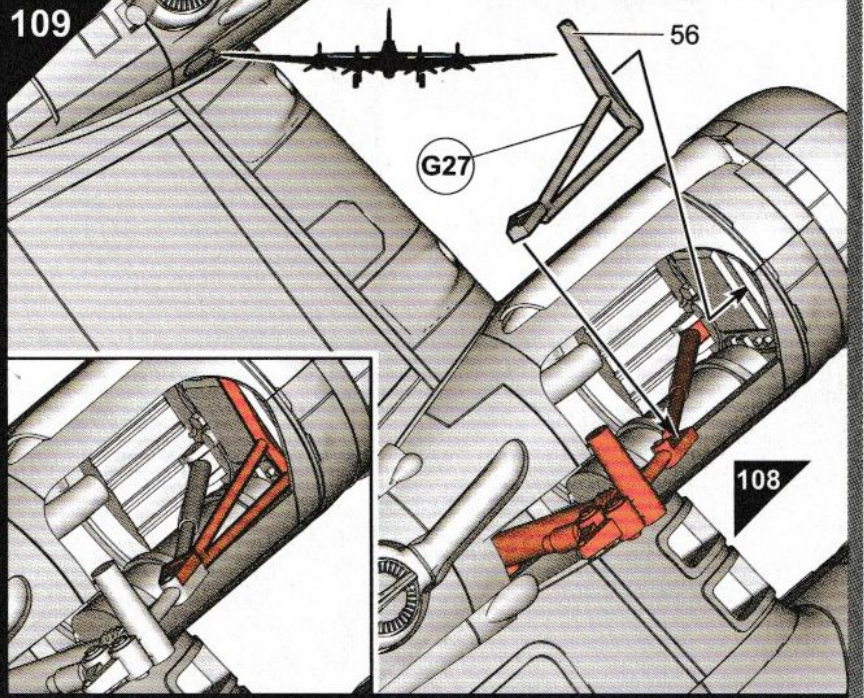
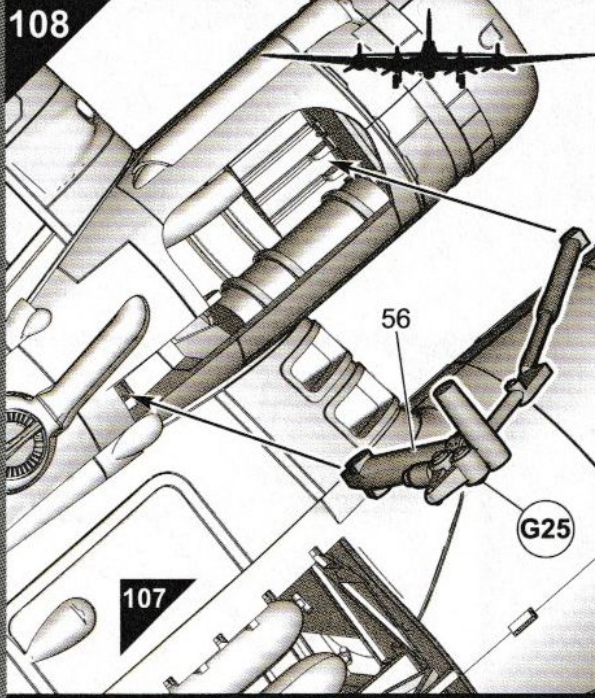
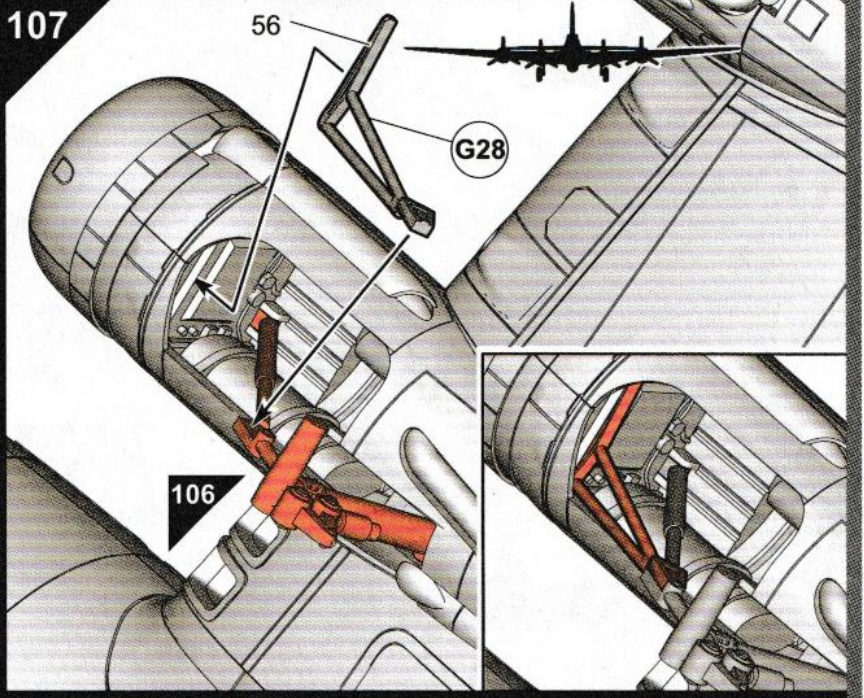
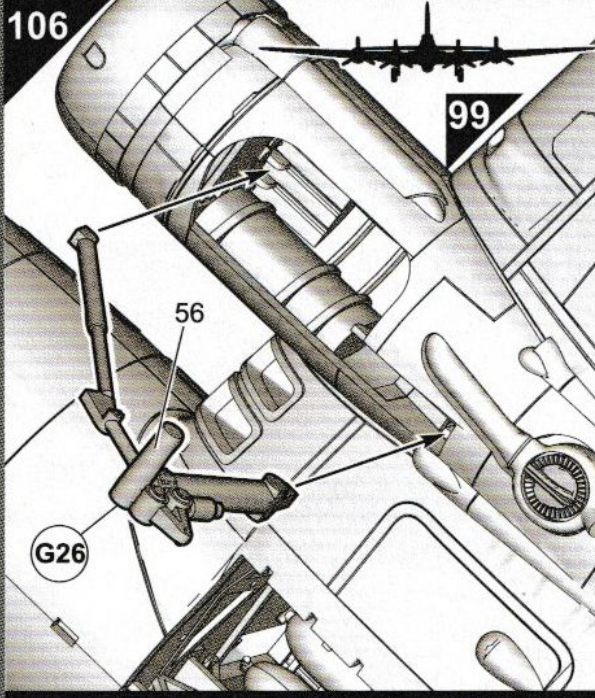

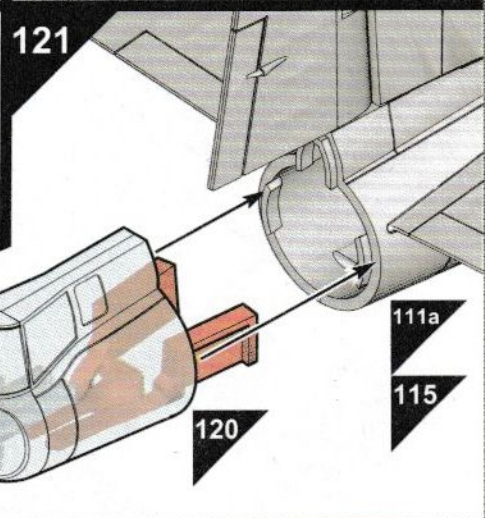
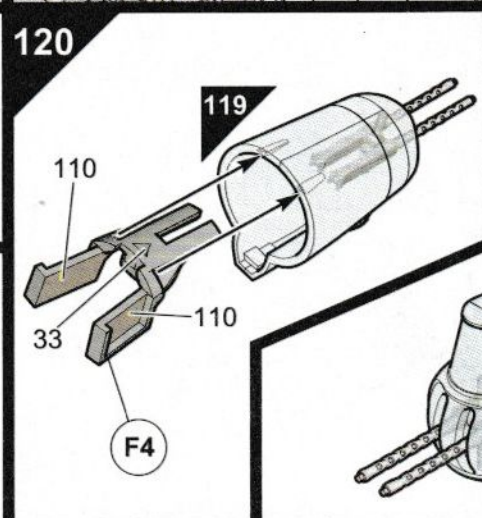
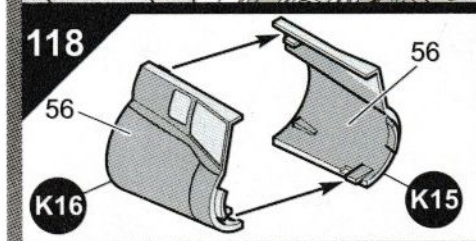
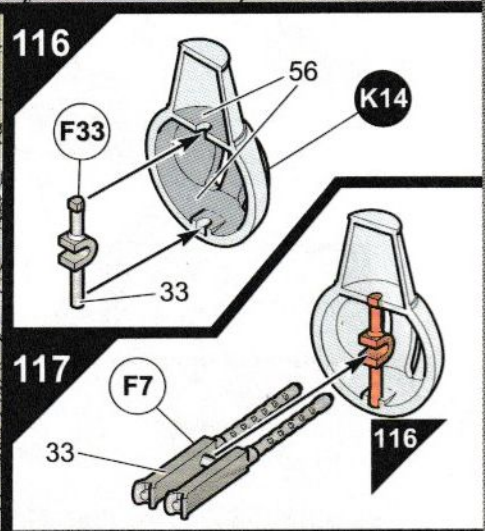
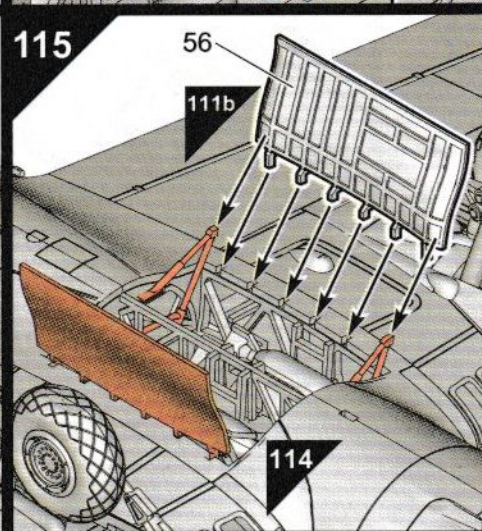
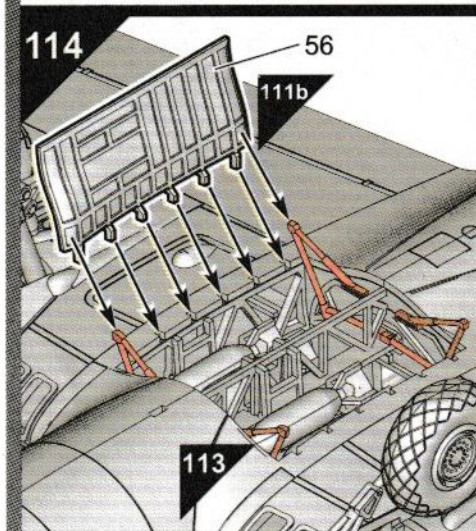
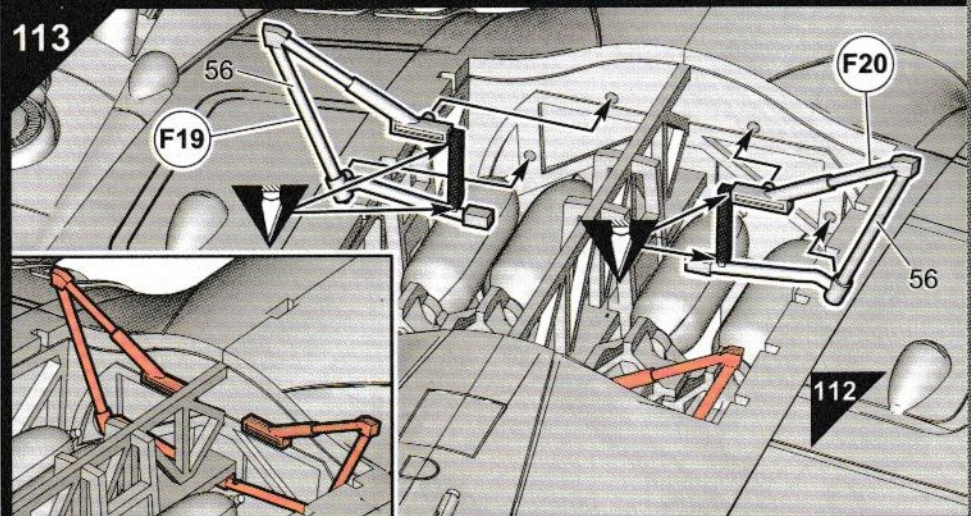
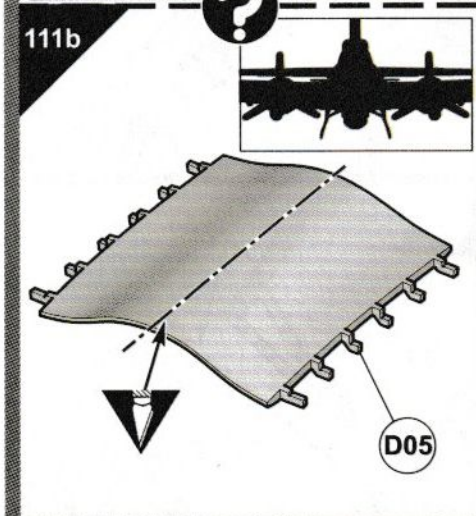
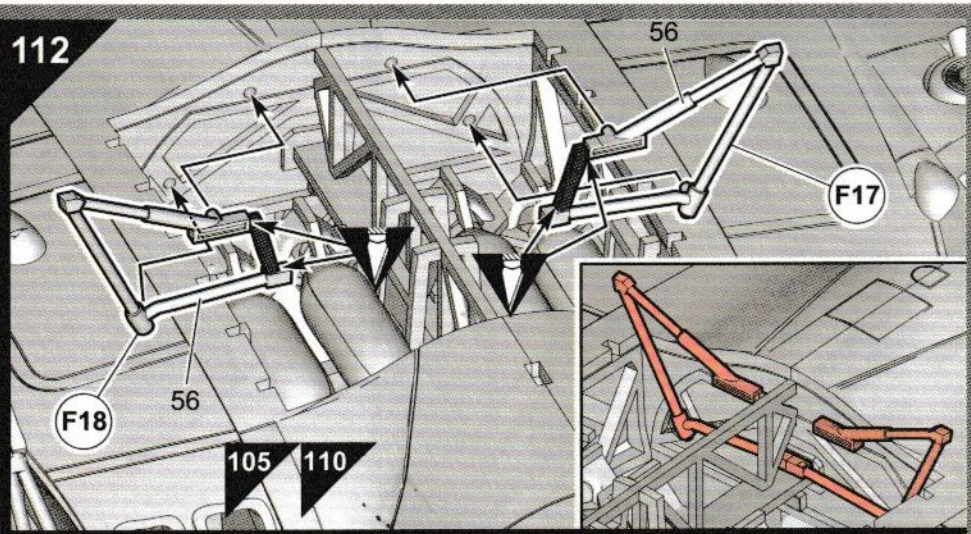
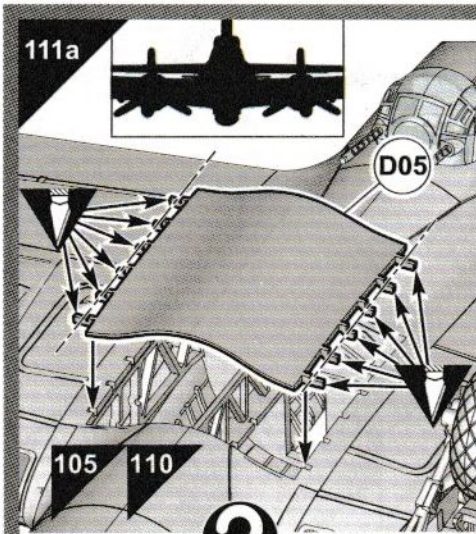

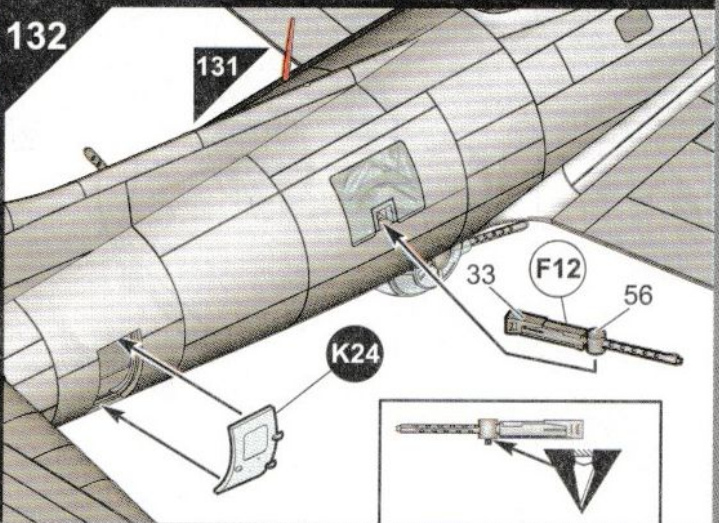
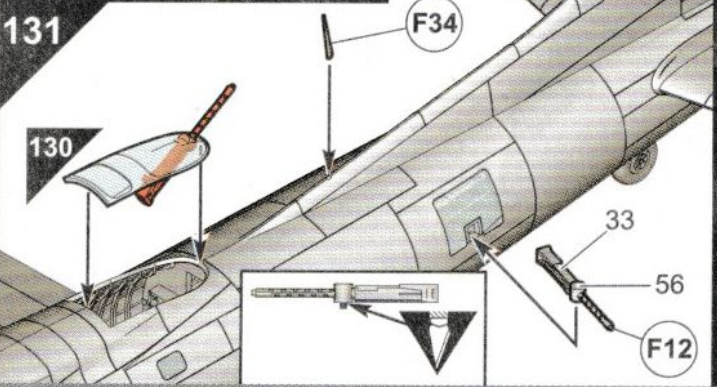
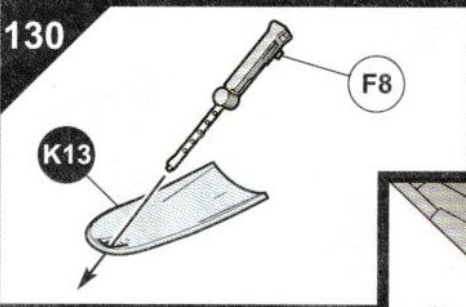
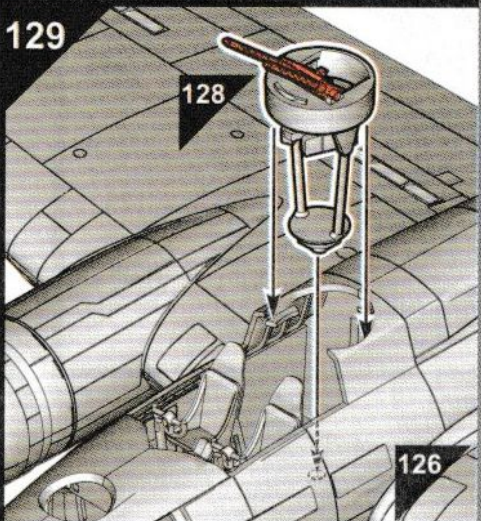
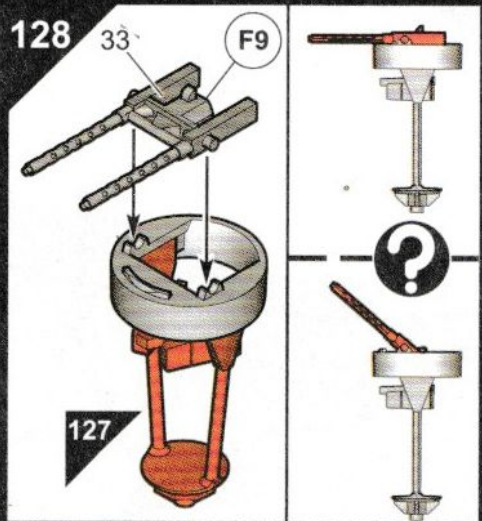
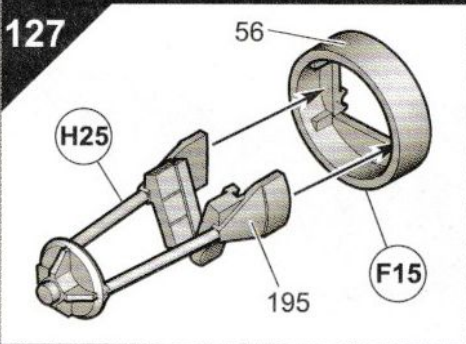
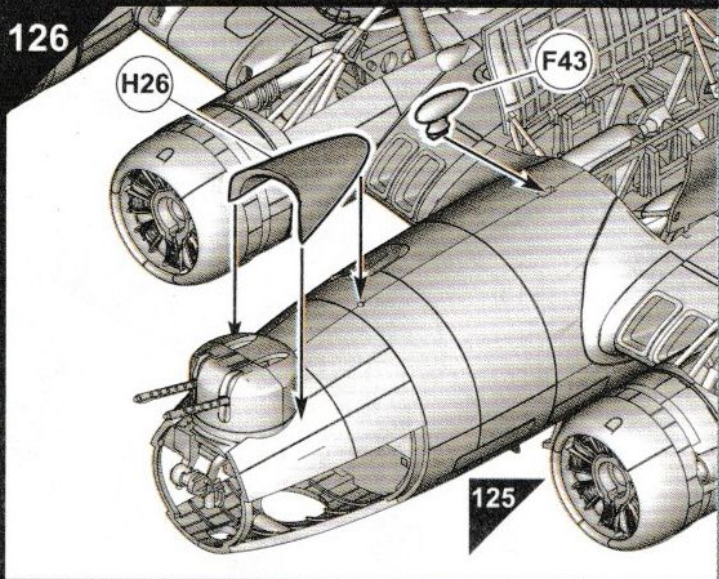
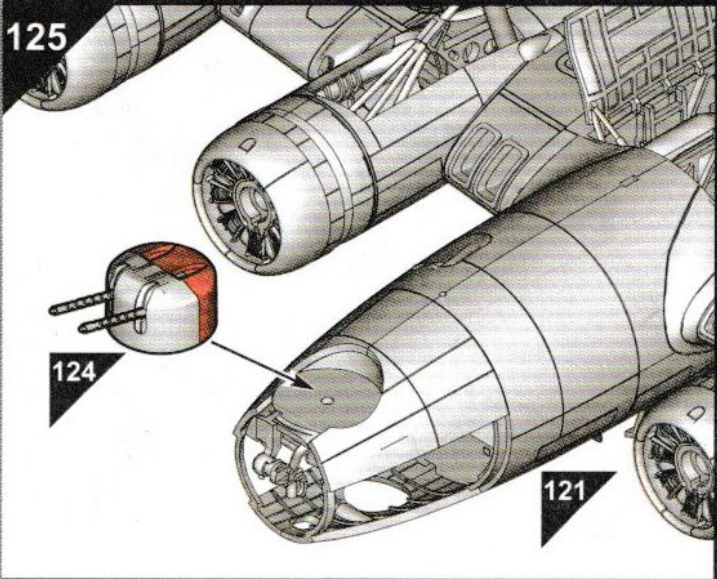
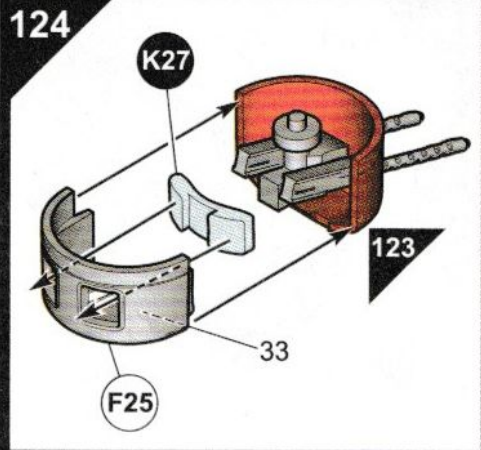
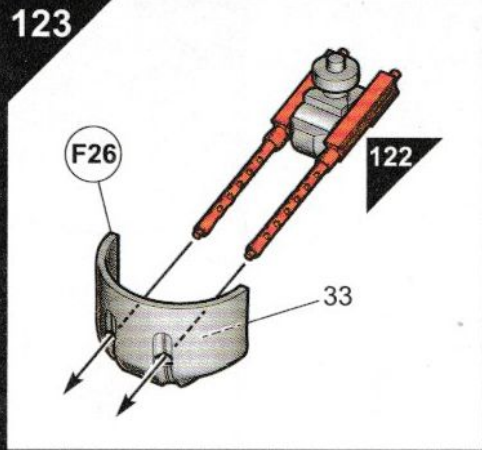
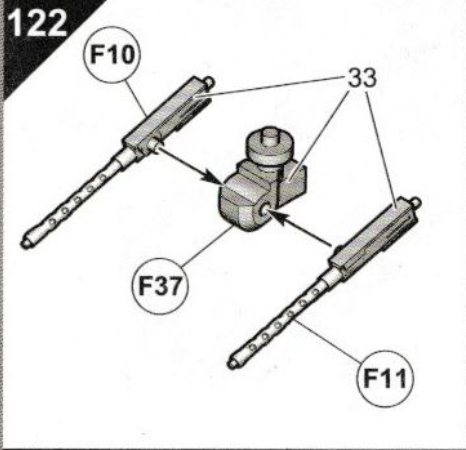

133

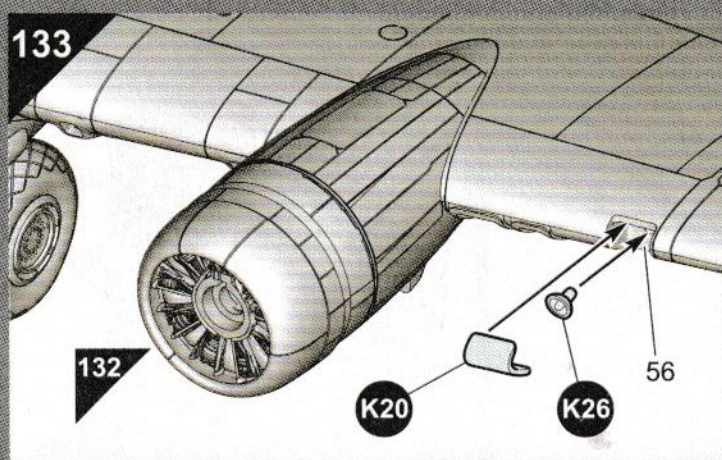

134

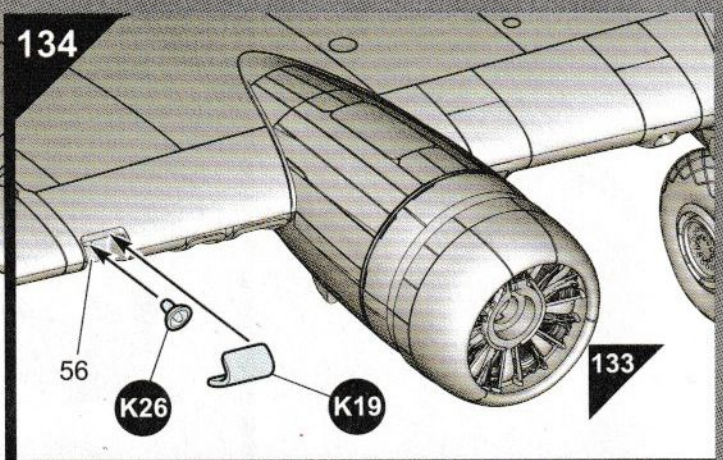

135

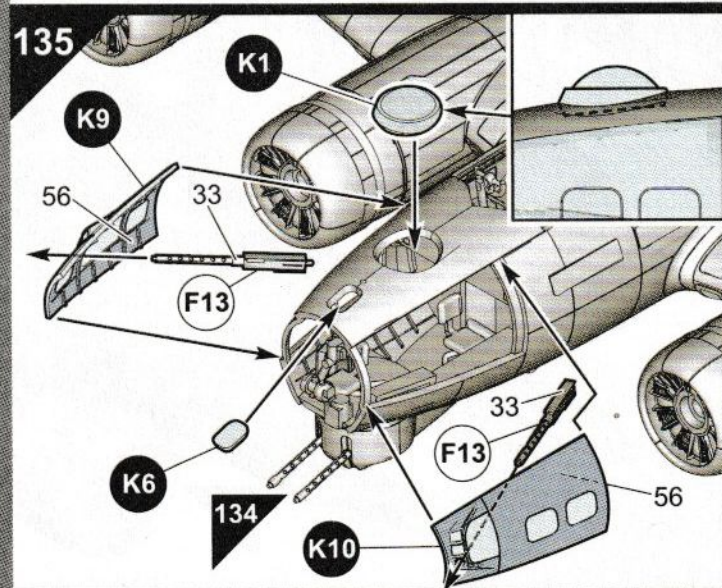

136

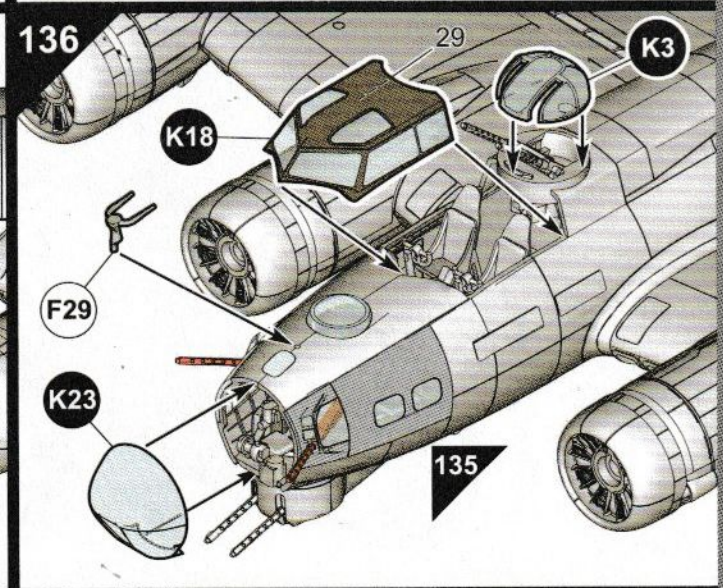

137

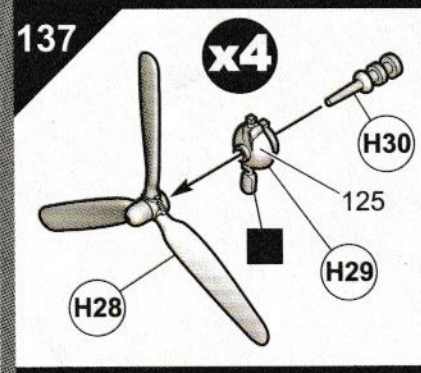

138

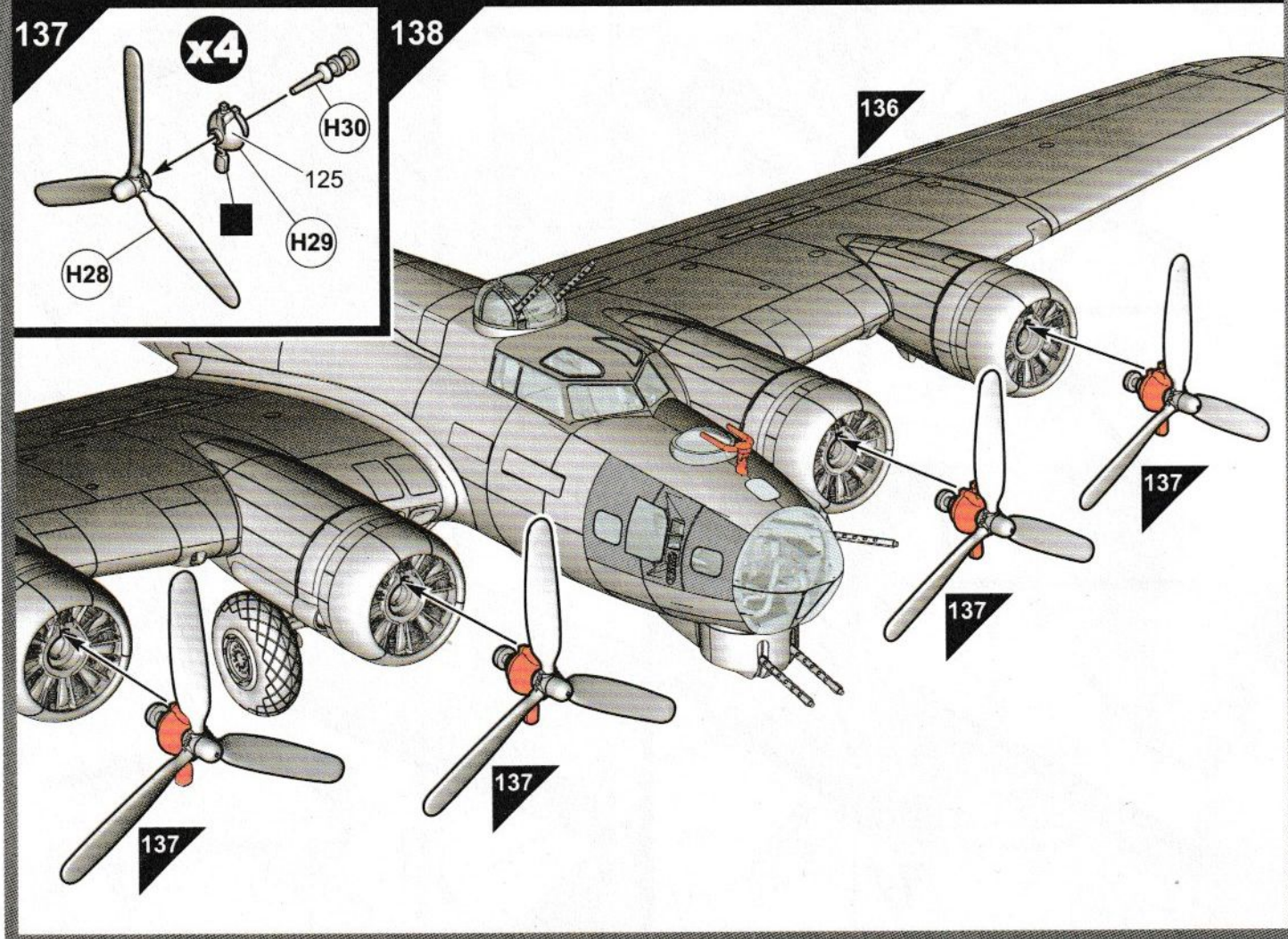

A Boeing B-17G-65-BO

43-37521 'Skyway Chariot', 351st Bomb Squadron, 100th Bomb Group
 Royal Air Force Thorpe Abbotts, Norfolk

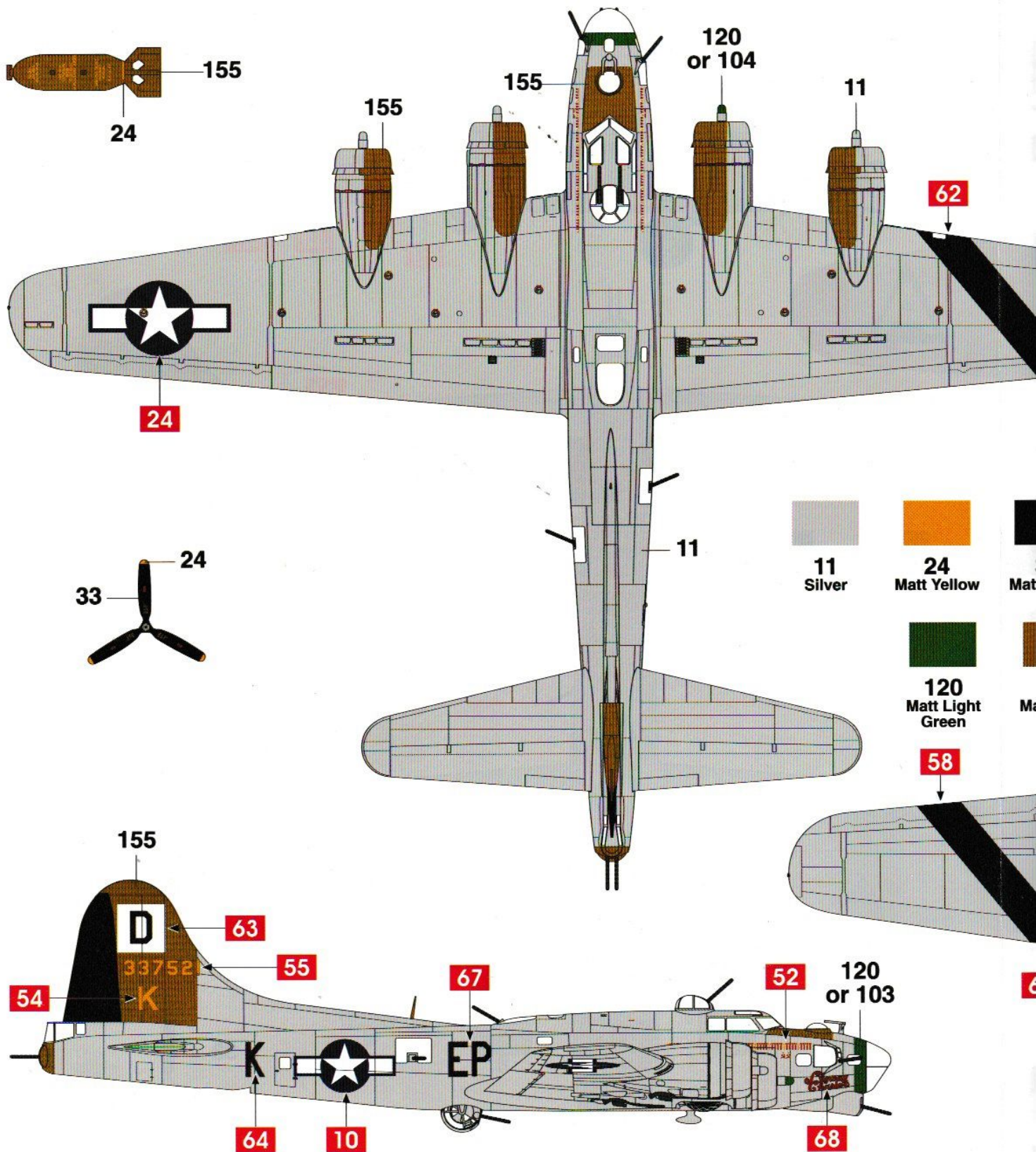

5-BO Flying Fortress™

Bomb Group, Eighth Air Force, United States Army Air Force,
 tts, Norfolk, England, March 1945.

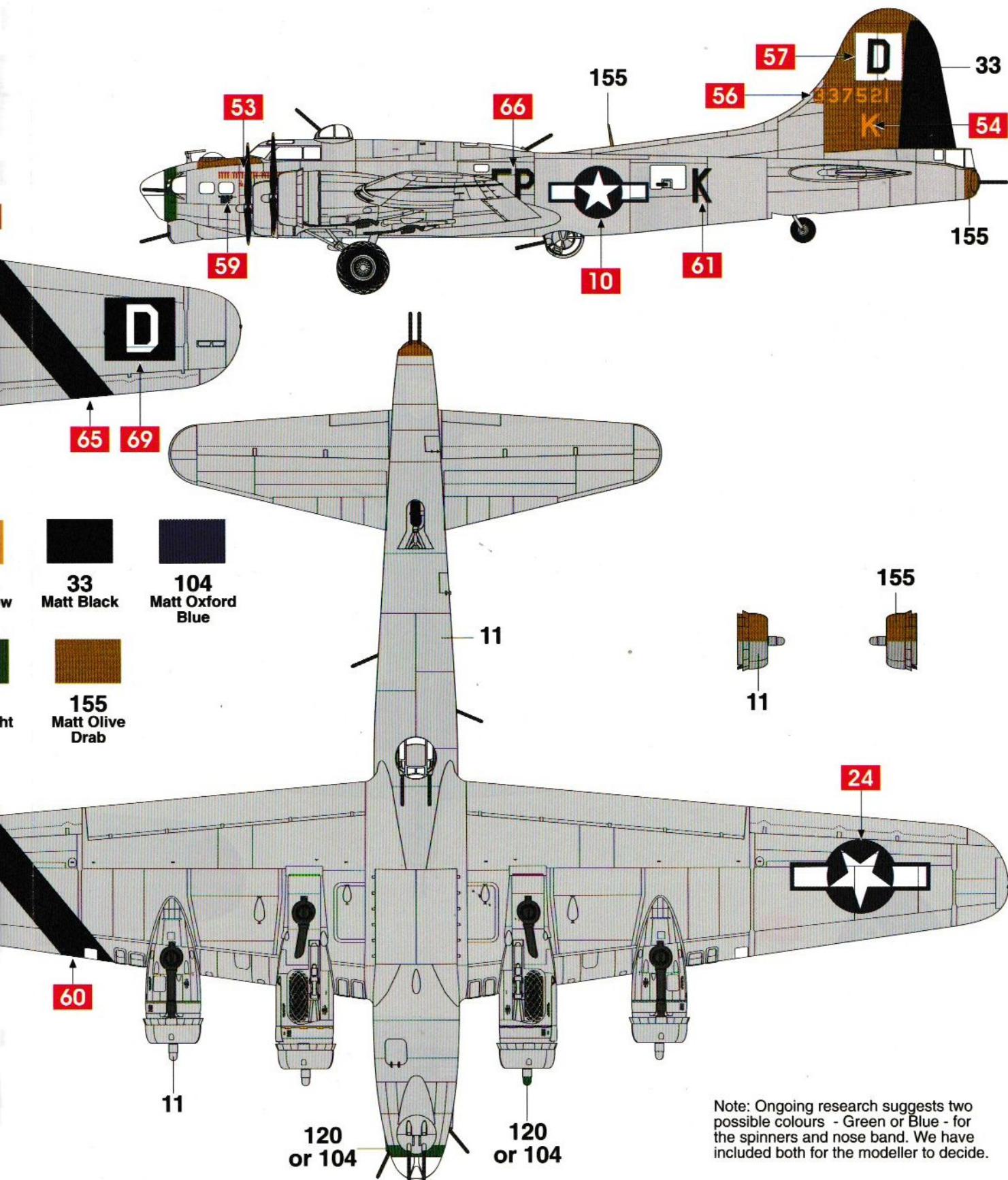

Note: Ongoing research suggests two possible colours - Green or Blue - for the spinners and nose band. We have included both for the modeller to decide.

B Boeing B-17G-75-BO

43-37993 'Mah Ideal', 324th Bomb Squadron, 91st Bomb Group
 Royal Air Force Bassingbourn, Camb

'Mah Ideal' 401st Bomb Squadron early 1945

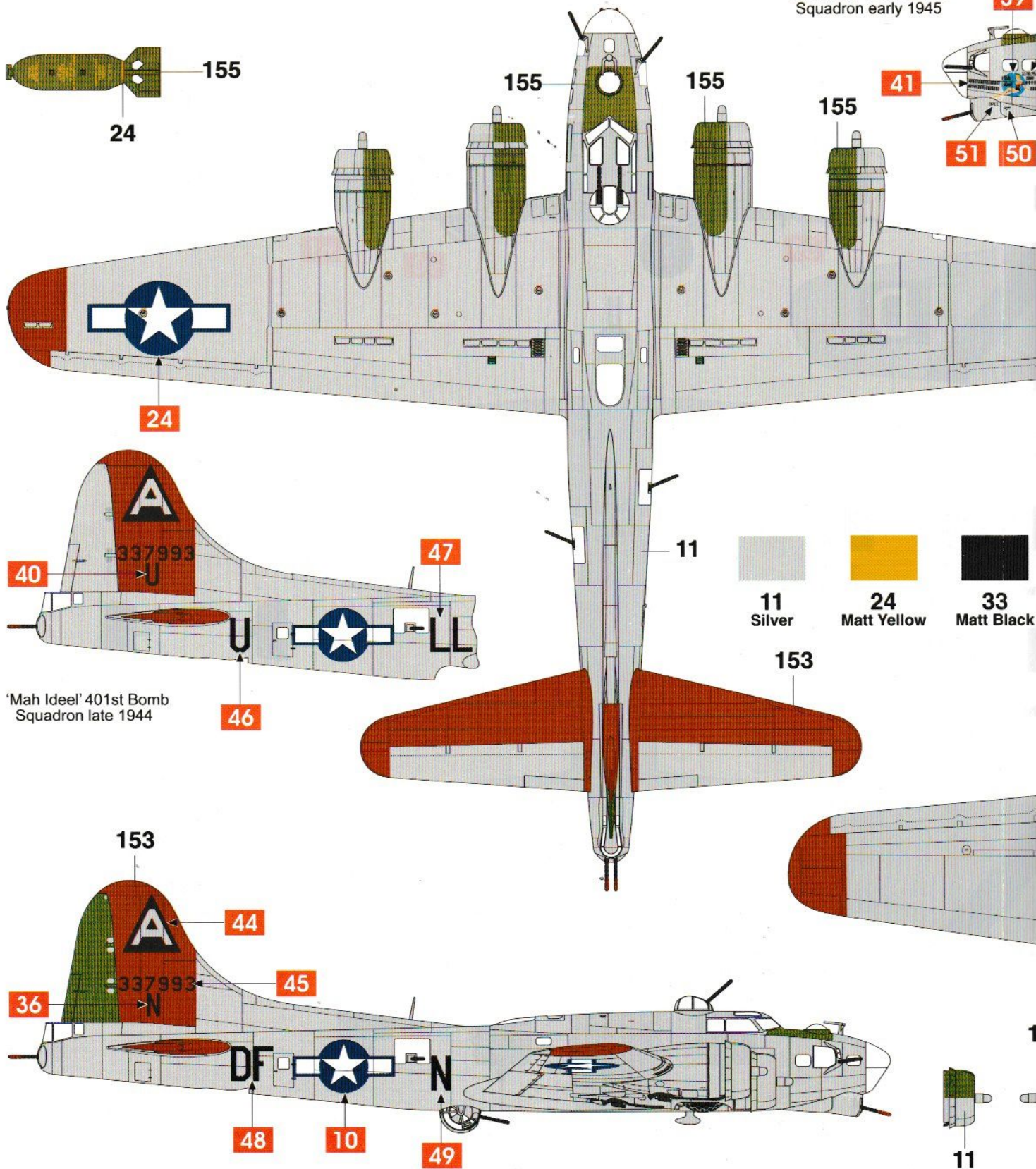

'Mah Ideal' 401st Bomb Squadron late 1944

B-29 Superfortress Flying Fortress™

44th Bomb Group, Eighth Air Force, United States Army Air Force, Cambridgeshire, England, early 1945.

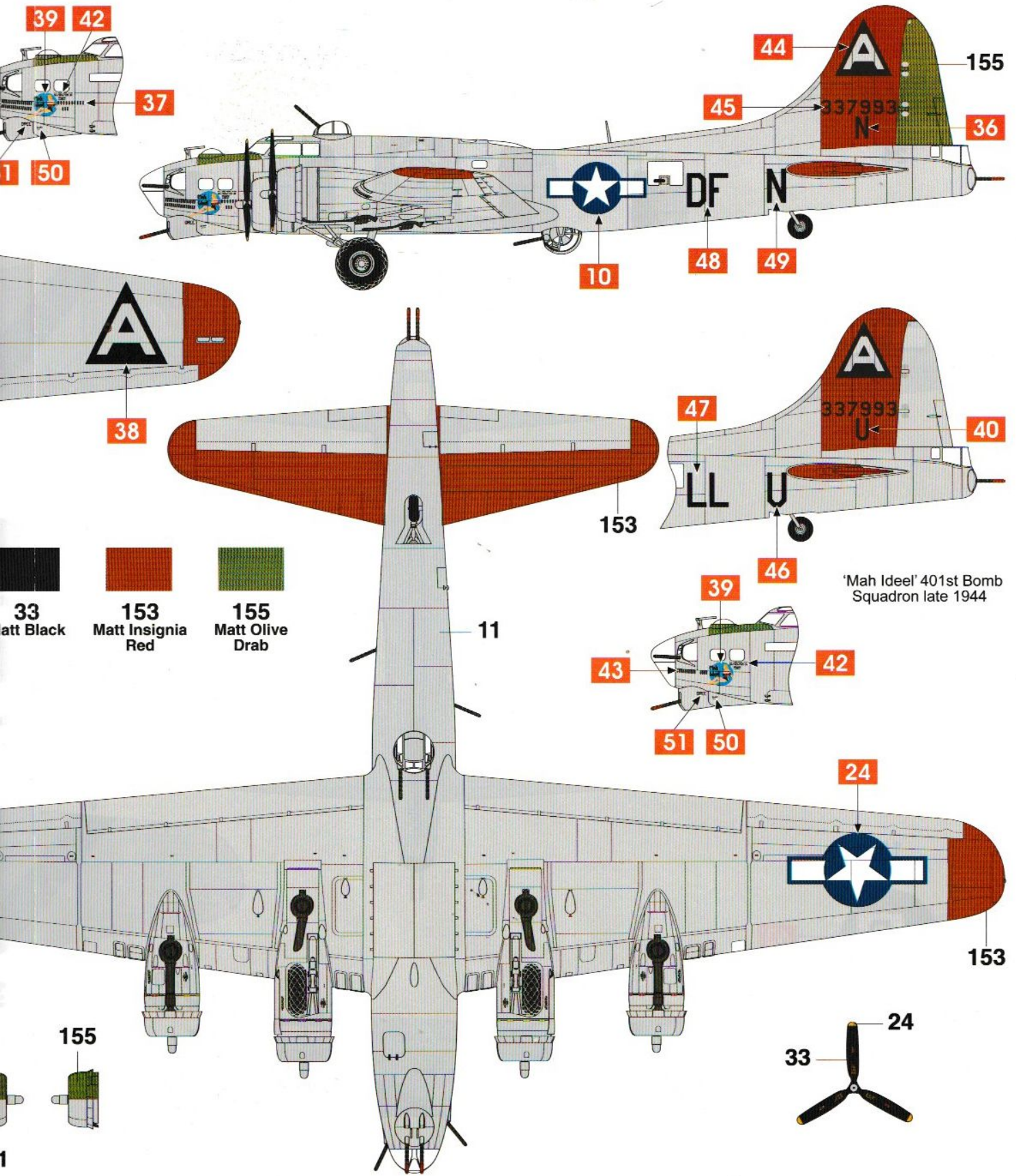

- 33 Matt Black
- 153 Matt Insignia Red
- 155 Matt Olive Drab

'Mah Ideal' 401st Bomb Squadron late 1944

Boeing B-17G Flying Fortress

Position of components

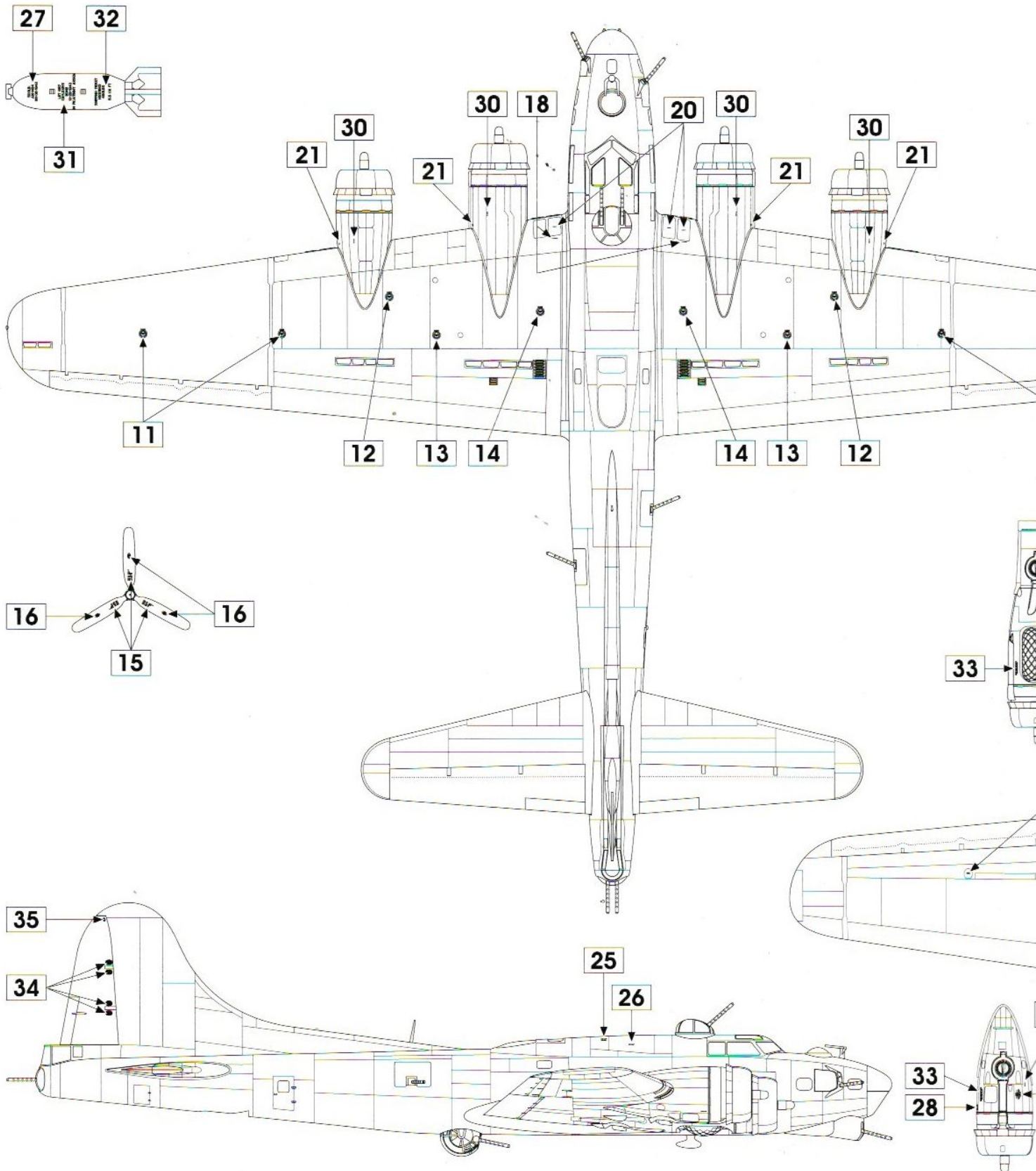

7G Flying Fortress™ common stencil data

