



# 1/48 scale Gloster Meteor

T648601

## IMPORTANT! READ THESE POINTS BEFORE YOU BEGIN

- 1 This kit may be built more than one way. Decide on which version you wish to build before final assembly.
- 2 "TEST FIT" all parts before cementing. Cement all parts unless otherwise indicated by the instructions.
- 3 Use paint and cement made for styrene plastic only. Trim excess plastic from parts before joining.
- 4 Paint all sub-assemblies before attaching parts.
- 5 Scrape paint away from surfaces to be cemented together.
- 6 Follow all of the numbers on the instruction sheet beginning with number one.

### PAINT SUGGESTIONS

The following suggestions may be of help to you in painting your model: Use only bottle or spray paint made for styrene plastics. Allow time for paint to dry thoroughly before handling parts.

**FLAT SEA GRAY** (Pactra)—Lower portion of wings, fuselage, horizontal stabilizers, landing gear doors (open or closed).

**FLAT YELLOW** (Pactra)—Tip of V-1 missile.

**FLAT TAN** (Testor #1167)—Pilot's face and hands.

**FLAT BROWN** (Testor #1166)—Pilot's helmet and suit.

**SILVER** (Testor #1145)—Pilot's goggles, head set, landing gear (open position), dials on instrument panel and some of engraving on the inside of cockpit and landing gear.

**FLAT BLACK** (Testor #1249)—Pilot's shoes, seat, mask, instrument panel, interior walls, landing gear doors (open or closed), wheels (forward and wing), control stick, interior floor, inside of cockpit and wheel openings (forward and wings).

**FLAT GREEN** (Pactra)—Antenna, V-1 missile  
**FLAT BATTLE GRAY** (Testor #1163)—Frame of canopy. **FLAT GREEN & FLAT BATTLE GRAY**—For camouflage effect, paint upper portion of wings, fuselage, horizontal stabilizers. Use box art for reference.

## 1. FUSELAGE ASSEMBLY

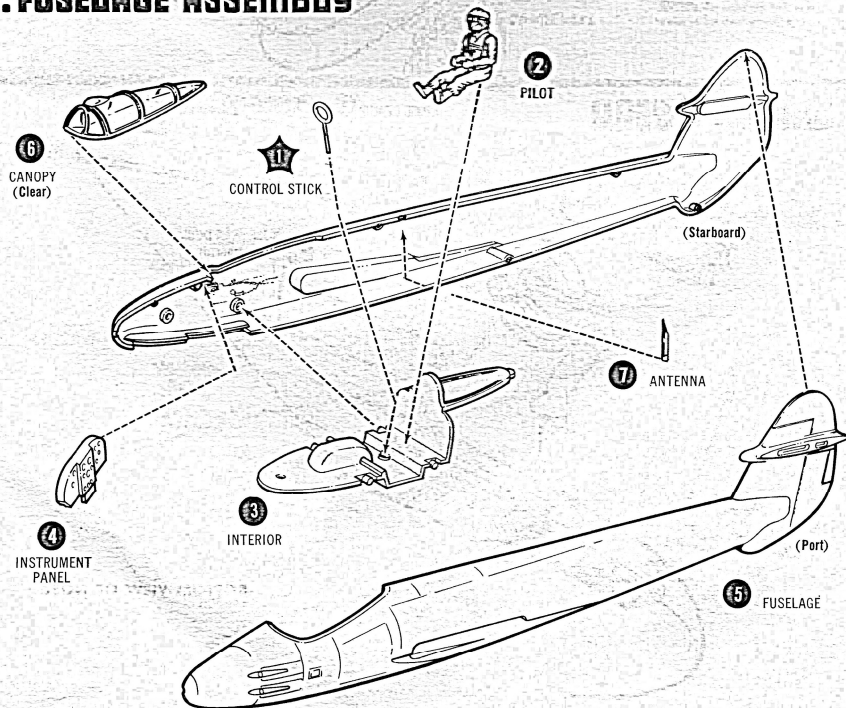

## 2. WING ASSEMBLY

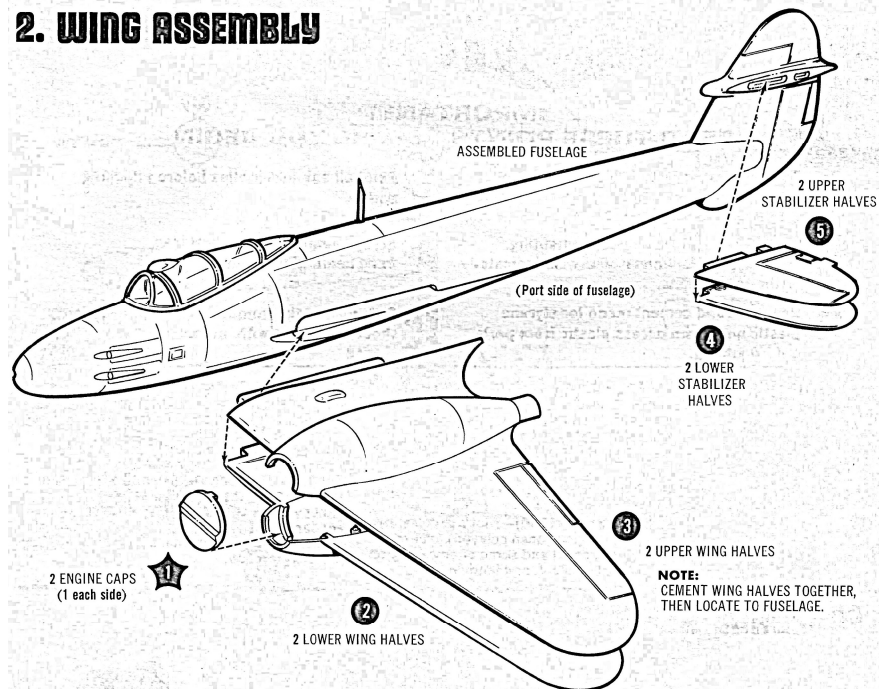

## 3. LANDING GEAR

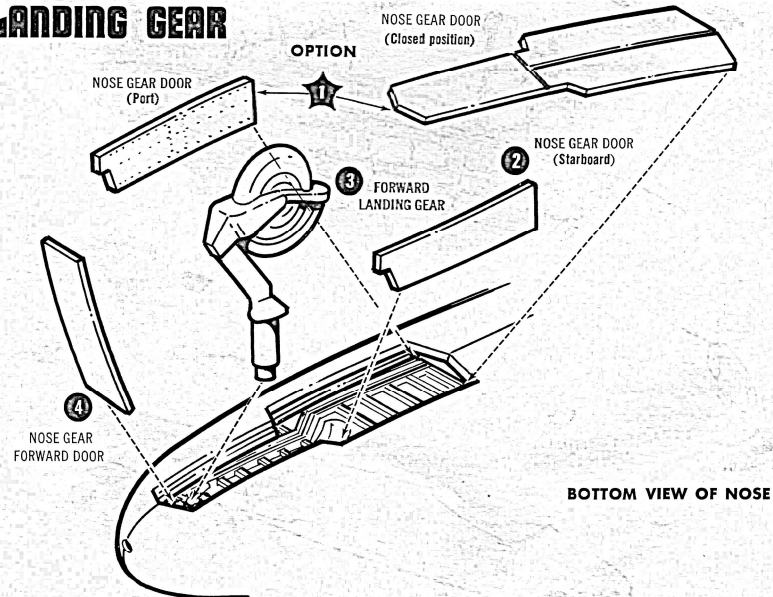

## 4. LANDING GEAR (Continued)

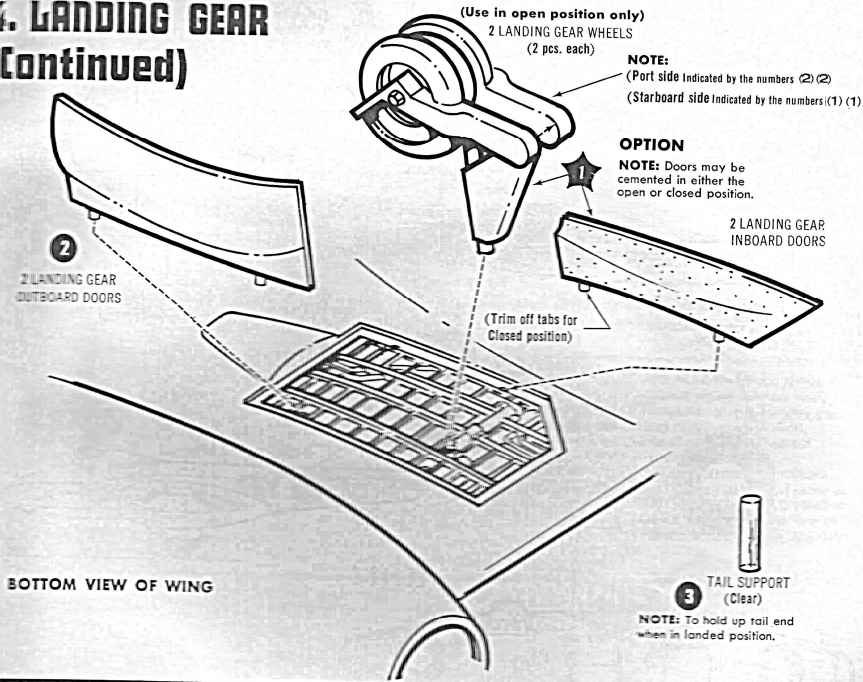

## J-1 ROCKET ASSEMBLY

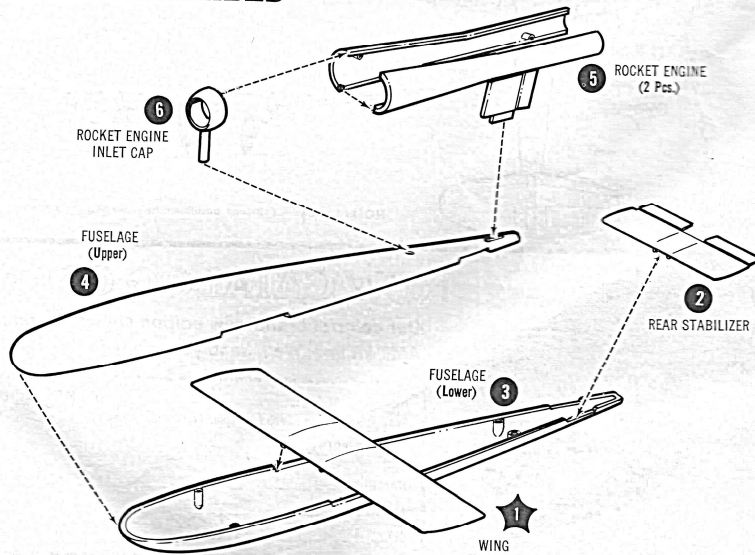

## DECAL PLACEMENT

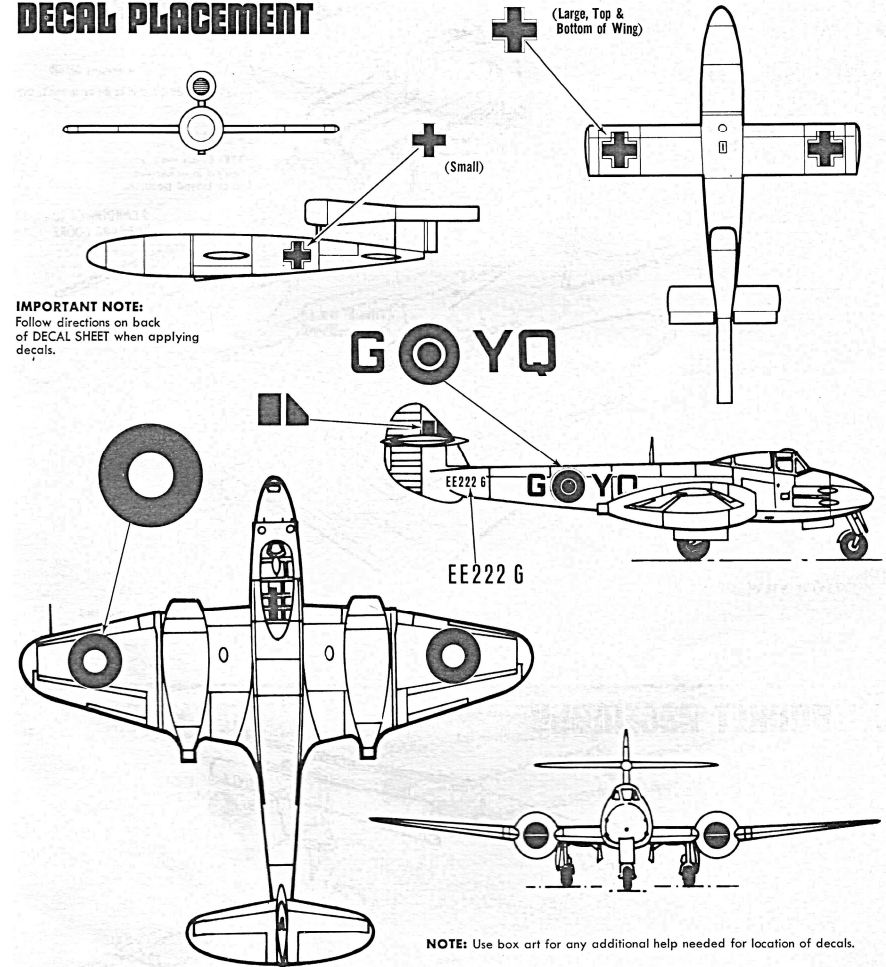

## NEW CATALOG OFFER!

Our colorful brand-new edition shows the entire AMT kit line. We'll send your copy for only \$1.00

I am enclosing \$\_\_\_\_\_ for \_\_\_\_\_ of AMT'S catalogs.  
Send to AMT Corp., 1225 E. Maple, Troy, Mich. 48064.

(PLEASE PRINT)

NAME \_\_\_\_\_  
ADDRESS \_\_\_\_\_  
CITY \_\_\_\_\_ STATE \_\_\_\_\_ ZIP \_\_\_\_\_