

Kit No. 72528

Lockheed Vega 5 / float plane

PLASTIKOVÝ MODEL LETOUNU
PLASTIC AIRCRAFT KIT

1/72

PLASTIK FLUGZEUG MODELLBAUSATZ
MAQUETTE RÉDUITE EN PLASTIQUE

CZ

Lockheed Vega, zejména modely 5 patří mezi nejslavnější letadla historie. Proslavily je hlavně rekordní lety nejruznějších pilotů i pilotek. Konstruktor J.K. Northrop v roce 1927 pro firmu Lockheed navrhl hornoplošný jednomotorový dopravní letoun. Vega měla samonosné křídlo a dřevěný skořepinový trup, na tehdejší dobu extrémně pevný a hladký. Ve své době představovala vrchol aerodynamiky. První prototyp vzletl 4. července 1927. Po ukončení zkoušek jej zakoupil G. Hearst jun. pro závod Dole Race. Při přípravě na závod však letoun zmizel nad Tichým oceánem. I přesto se rozeběhla sériová produkce, Vega byla vyráběna v modelech 1 až 4, lišících se motory a vybavením. Model 5 se od starších verzí odlišoval tím, že dostal kryt motoru NACA, podle typu motoru se dále rozlišovaly podverze 5A, 5B a 5C. Vegy používaly hlavně americké letecké společnosti k přepravě cestujících, nákladů a pošty. Díky exportu sloužily u leteckých společností v Argentině, Mexiku a Kanadě, jednotlivé kusy létaly po celém světě. Vyráběna byla i plováková verze a verze s kovovým trupem označovaná DL-1 Special. Ještě za druhé světové války byly jednotlivé kusy používány letectvy USA a RAAF jako transportní.

Vega C/n 99 (Constructor's number Lockheed) imatrikulovaná NC47M byla postavena jako verze 5B v roce 1930 a začala létat u společnosti Julian Oil Co. V květnu 1931 byla upravena na verzi 5C. V průběhu let 1931-34 vystřídalala různé letecké společnosti. V roce 1934 u společnosti Alaska Air Express dostala plováky. Pak již zůstala spojena s létáním na severu. Po epizodní službě u několika společností létala v letech 1936-1942 u Alaska Air Transport, Inc. V té době měla jméno Nugget. V roce 1942 byla prodána společnosti Alaska Coastal Airlines. Po slzání této společnosti létala až do osudného dne 15. 1. 1958. Tohoto dne havarovala u Tenakee na Aljašce. Pilot Fred B. Sheldon zahynul, dva pasažéři vyvázli. Šlo o nejdéle létající plovákovou Vegu vůbec.

Tech. data: rozpětí: 12,5 m; délka: 8,38 m; max. rychlost: 305 až 340 km/h (dle verze); dostup 6700 m; dolet: 1100 km

GB

The Lockheed Vega, above all the series 5, is amongst the most famous aeroplane in history. Its fame is due in no small part to the records established by various pilots. In 1927 the designer J.K. Northrop designed a shoulder-wing, single-engined transport monoplane for the company Lockheed. The Vega had a self-supporting wing and wooden monocoque which was very firm and smooth and represented the apex of aerodynamics at that time. The first prototype had its maiden flight on 4 July 1927. At the end of the test flight it was bought by G. Hearst Jr. for the Dole Race competition. However, while preparing for the competition the plane disappeared without trace above the Pacific Ocean. Despite this production continued and the Vega was produced in models 1 to 4, differing in respect of engines and equipment. The model 5 was a departure from its older version in that the VACA engine was covered and the sub-versions the 5A, 5B and 5C had different engines. Vegas were mainly used by the American Air Force for the transportation of people, freight and post. Exports saw the plane doing service in Argentina, Mexico and Canada, and individual planes found their way around the world. A seaplane version was manufactured, as was a version with a metal body called the DL-1 Special. During the Second World War individual planes were used by the USAF and RAAF as transport planes.

Vega C/n 99 (Constructor's number Lockheed) matriculated NC47M was built as version 5B and started to fly at the Julian Oil Co. In May 1931 it was modified to version 5C. During the years 1931-34 it interchanged various aviation companies. In 1934 at the Alaska Air Express Co. it received floats. Afterwards it remained connected with flying in the north. After an episode service in several companies it was flying in 1936-42 at Alaska Air Transport, Inc. At that time it bore the name Nugget. In 1942 it was sold to the Alaska Coastal Airlines. In service with this company it flew until the fatal day of January 15, 1958. On this day it crashed near Tenakee on Alaska. Pilot Fred B. Sheldon perished, two passengers came out from this disaster. This aircraft was the longest time flying float Vega.

Technical data: Wingspan: 12.5 m; length: 8.8 m; maximum speed: 305 to 340 km/h (depending on the version); ceiling 6,700 m; range: 1,100 km

History, photos and technical references:
Tim Kalina, U.S.A.

Technical research:
Courtesy by Tim Kalina, U.S.A.

Lockheed VEGA

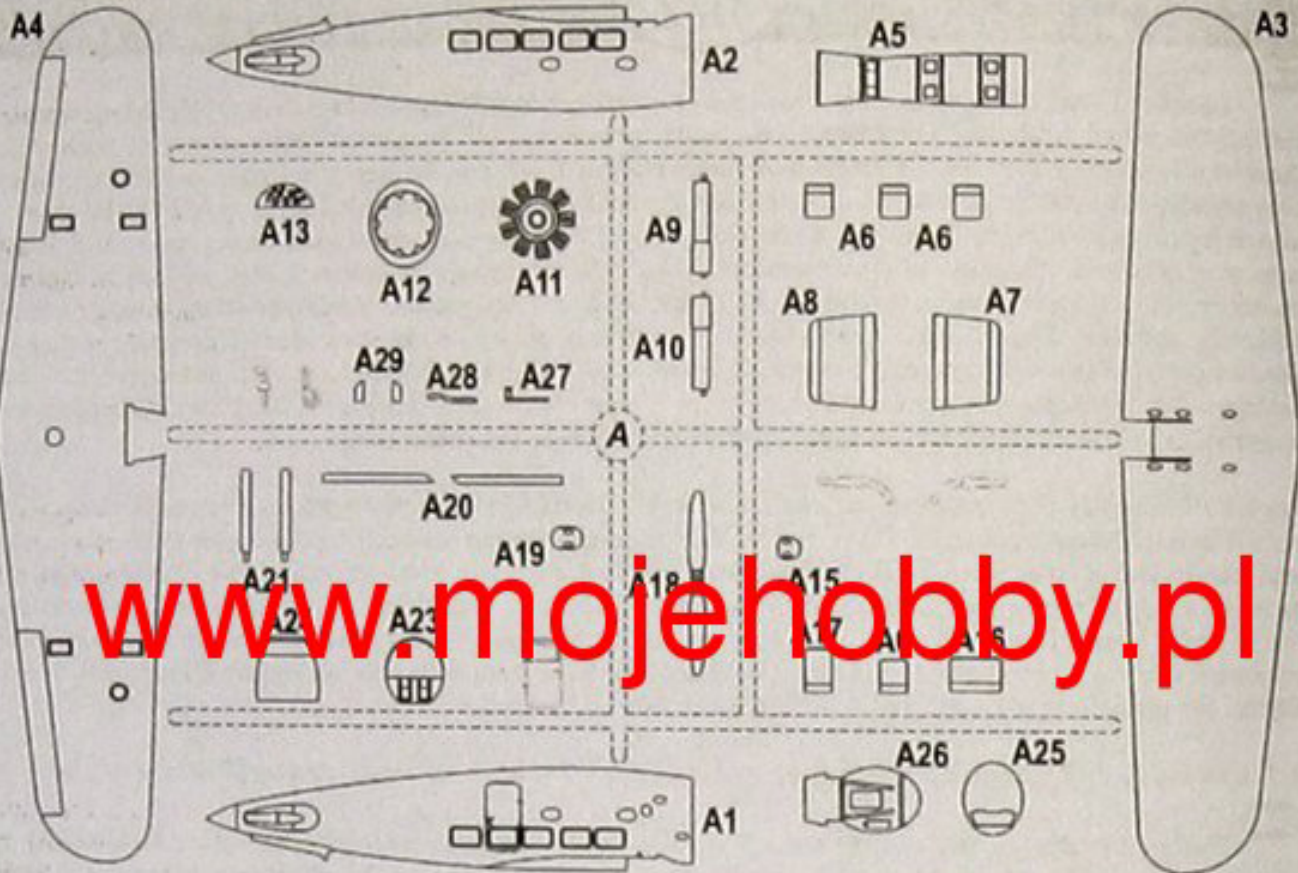

www.mojehobby.pl

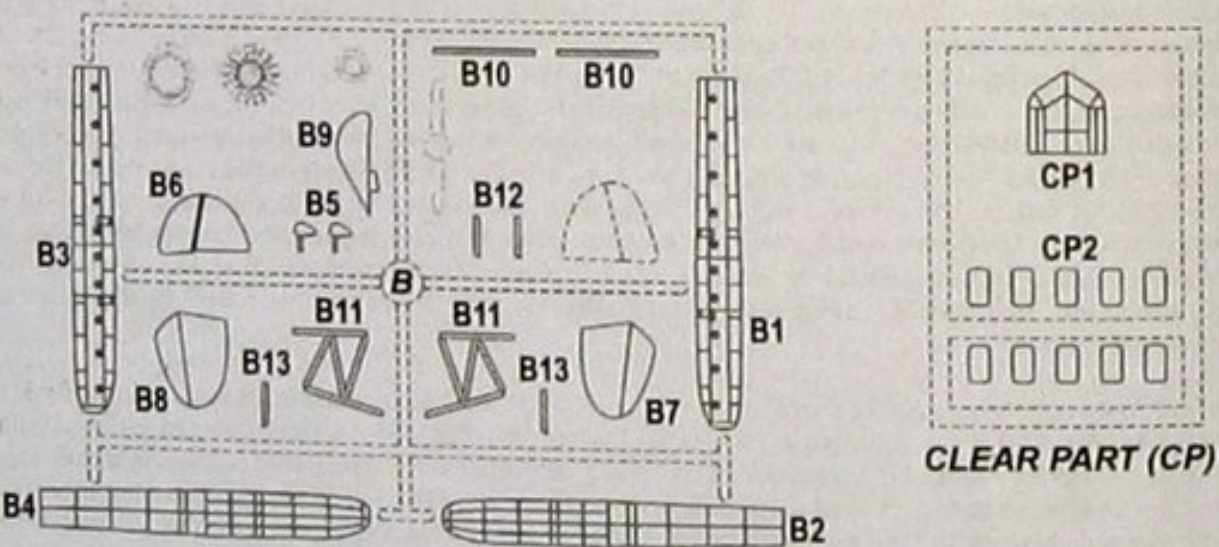

STEP

1

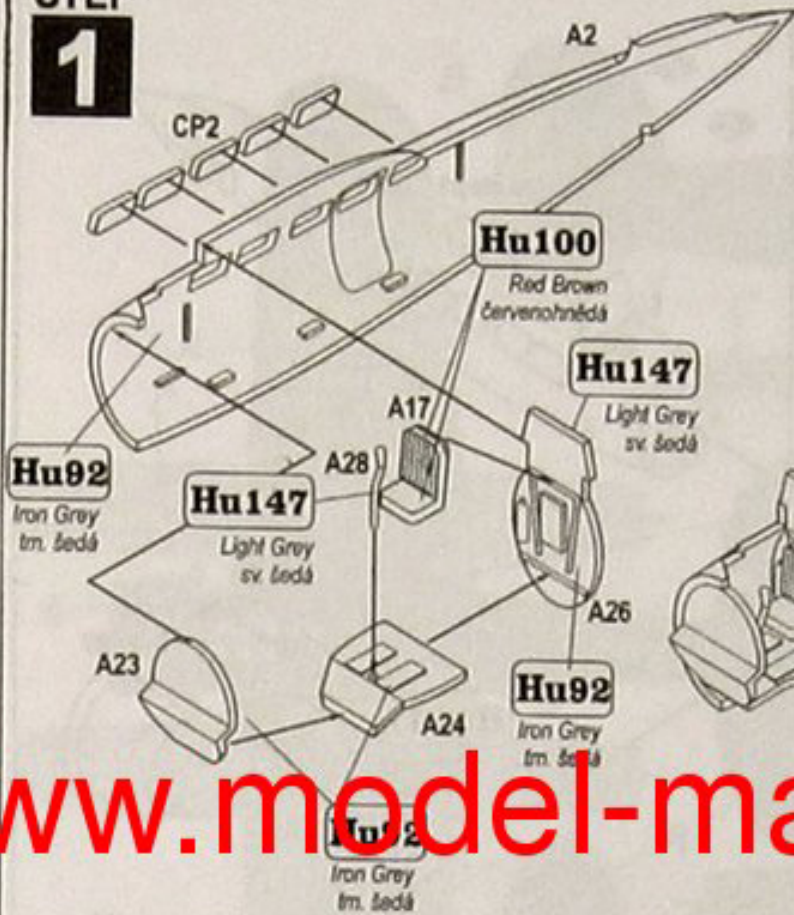

STEP

2

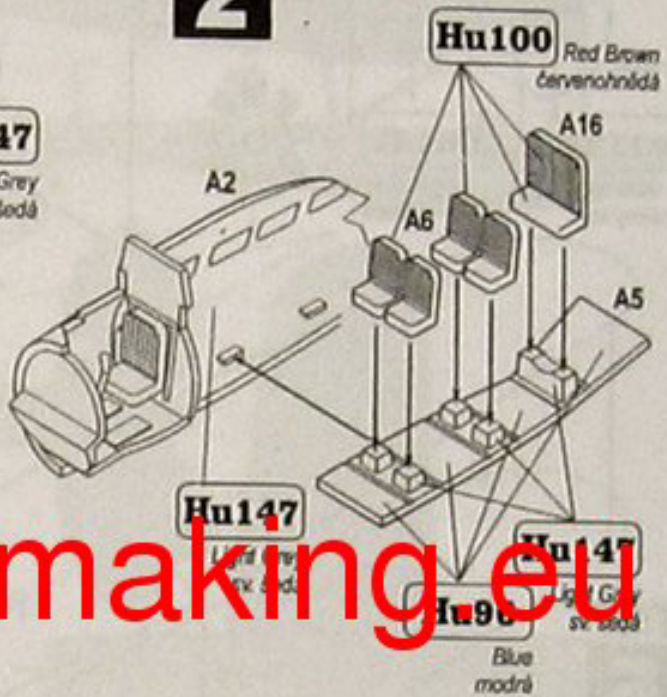

STEP

3

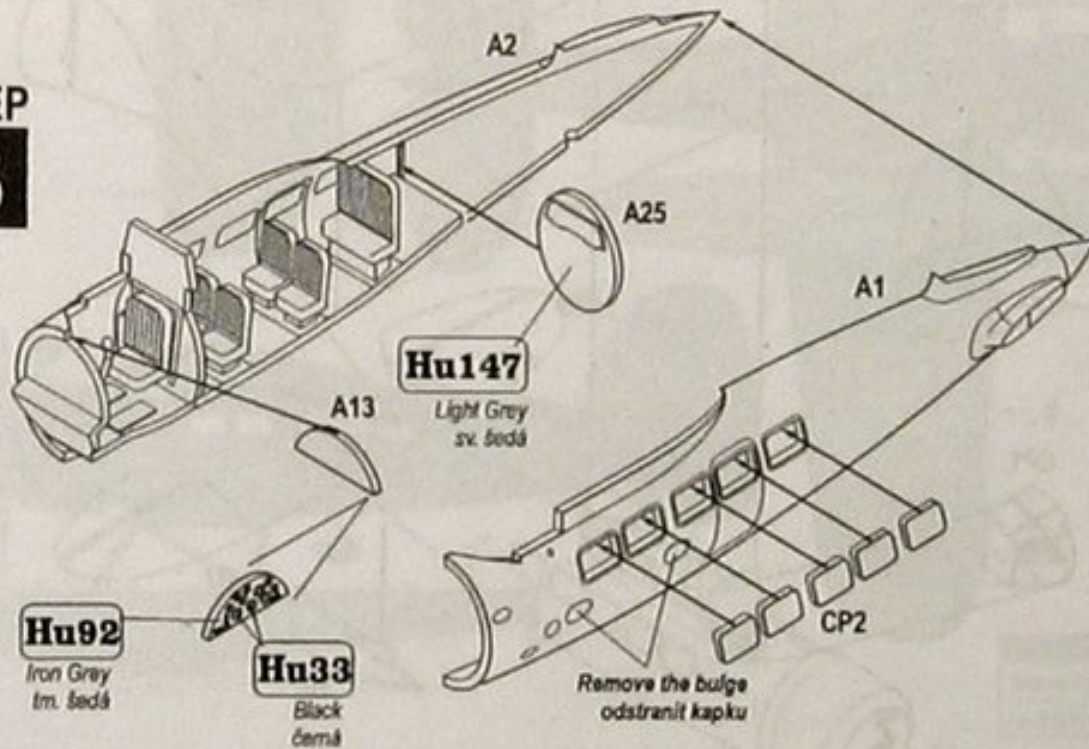

www.model-making.eu

"Vega Family" from

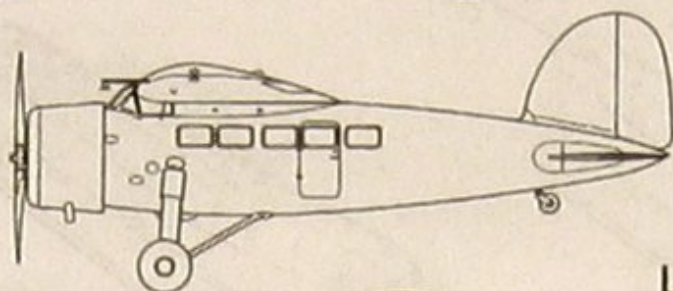

Kit No. 72522

PLASTIKOVÝ MODEL LETOUNU
PLASTIC AIRCRAFT KIT

1/72

Lockheed Vega 5/UC-101

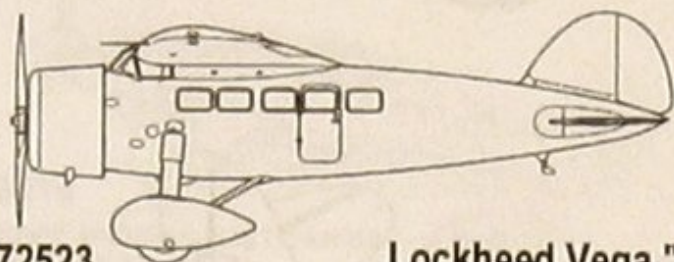

Kit No. 72523

PLASTIKOVÝ MODEL LETOUNU
PLASTIC AIRCRAFT KIT

1/72

Lockheed Vega "WINNIE MAE" / "LADY LINDY"

www.mojehobby.pl www.model-making.eu

"Next plane of the thirties"

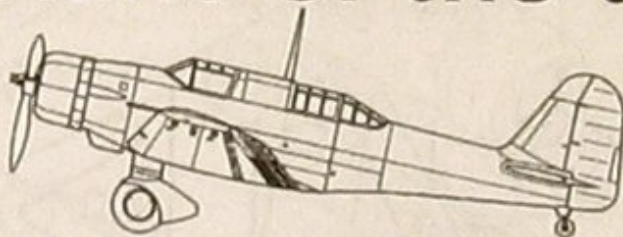

Kit No. 72504

PLASTIKOVÝ MODEL LETOUNU
PLASTIC AIRCRAFT KIT

1/72

Northrop A-17

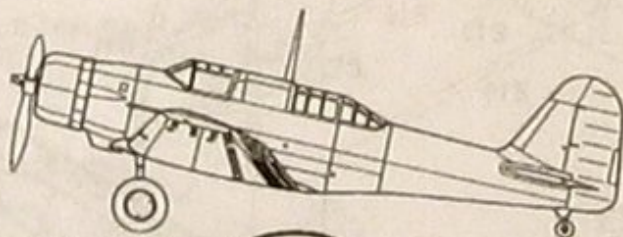

Kit No. 72521

PLASTIKOVÝ MODEL LETOUNU
PLASTIC AIRCRAFT KIT

1/72

Northrop A-17A

Více informací a termíny uvedení na trh žádejte v modelářských prodejnách nebo hledejte na internetu!

For more information and actual release date of all items please ask your local dealers or visit our websites!

internetový obchod/ MPM on-line shop!

www.mpm.cz

www.mpmshop.cz

STEP
4

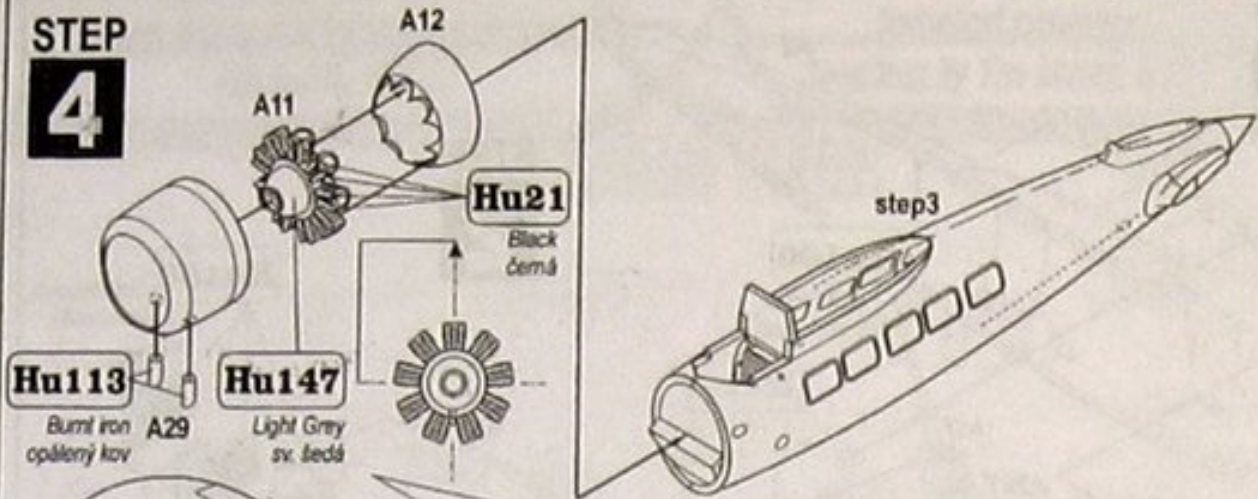

STEP
5

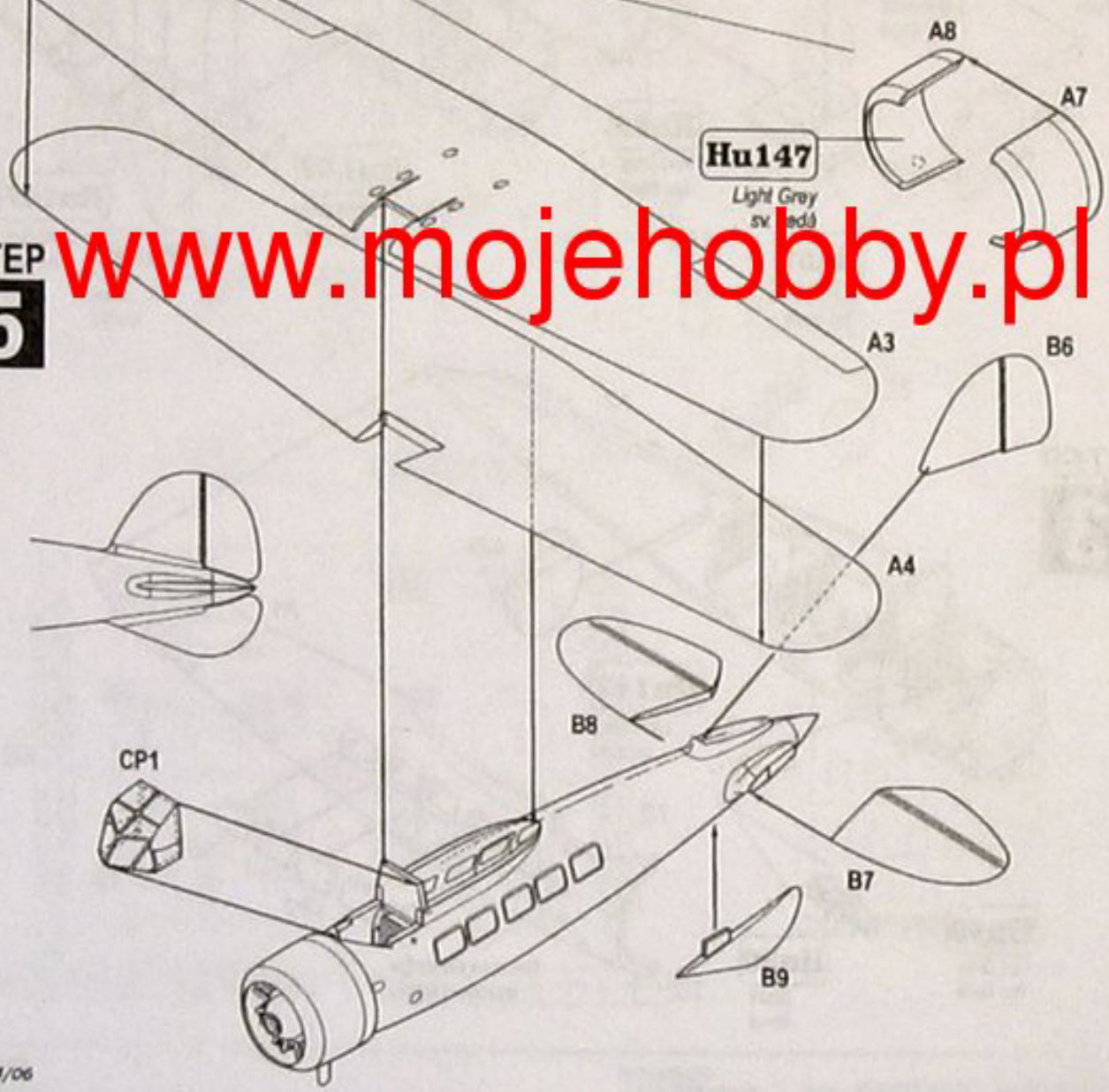

www.moje Hobby.pl

STEP

6

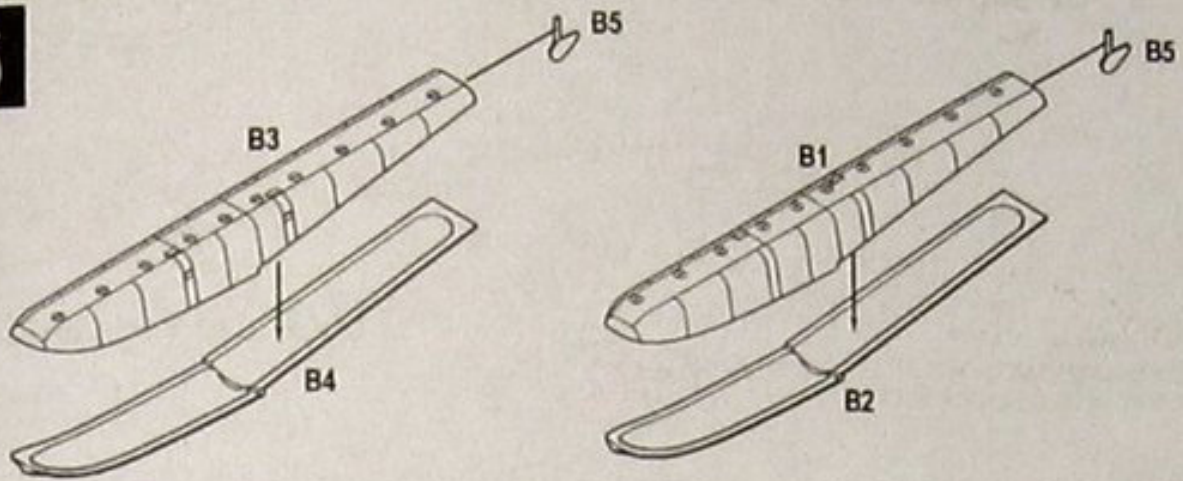

STEP

7

www.model-making.eu

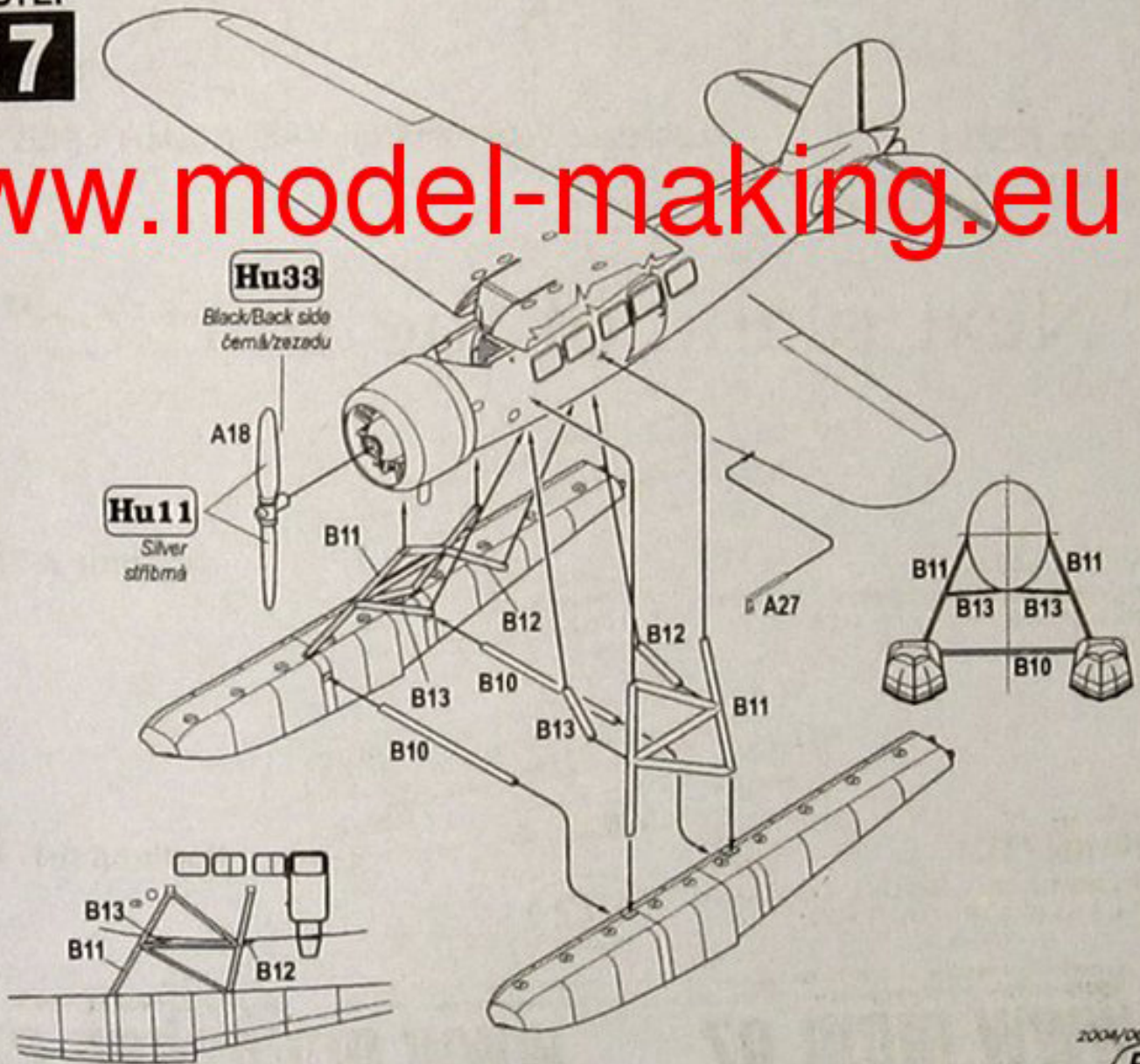

2004/06

ZBARVENI A OZNAČENI
CAMOUFLAGE AND MARKING

TARNUNG UND KENNUNG
CAMOUFLAGE ET DESIGNATION

Vega 5, C/n 99, NC47M

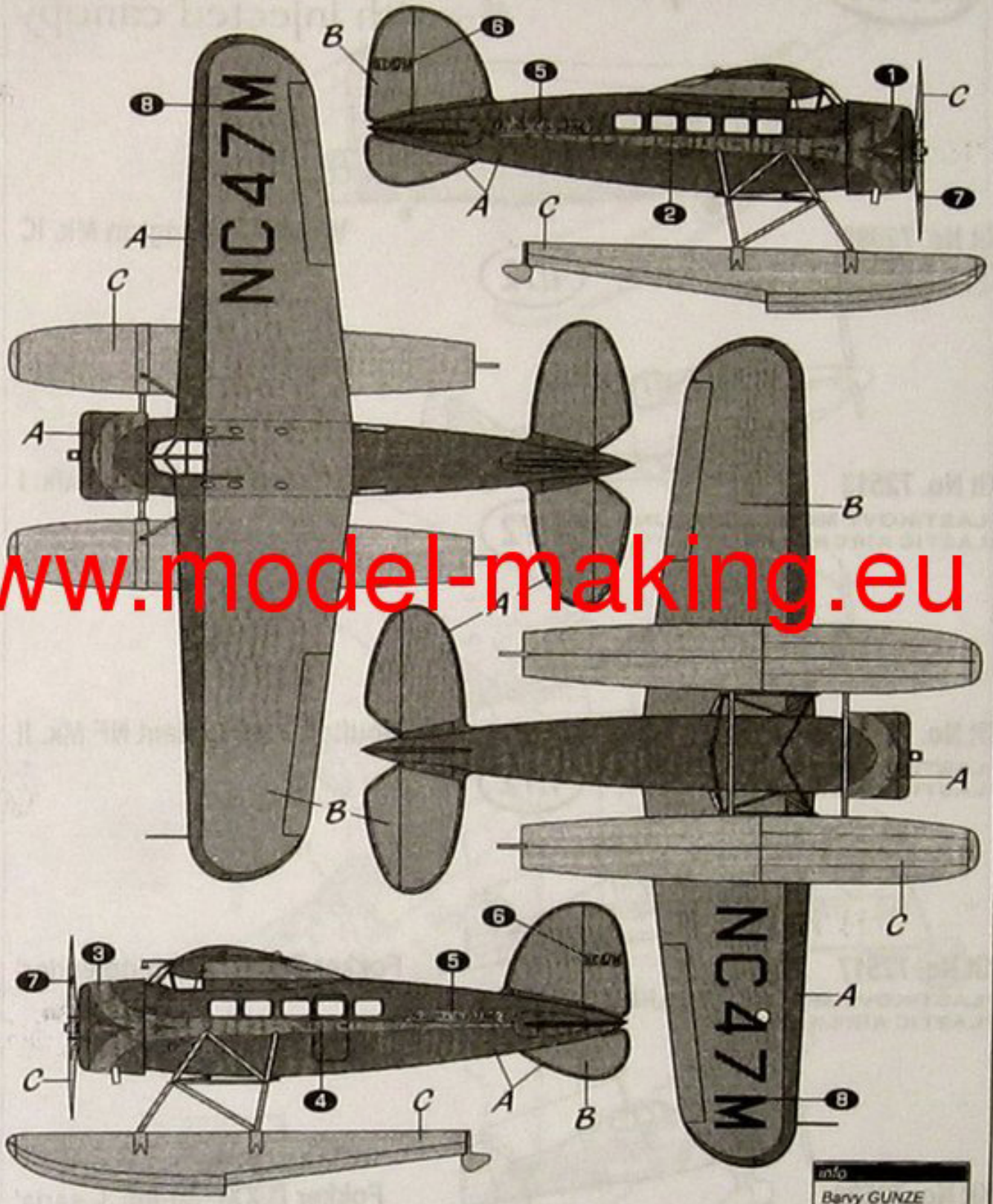

www.model-making.eu

info
Bary GUNZE
GUNZE colours No.

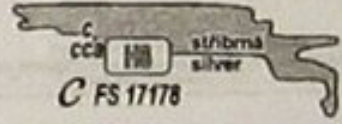
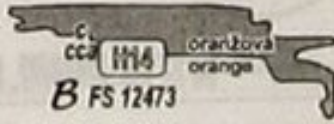



Top quality plastic kits
injected in metal moulds
with injected canopy

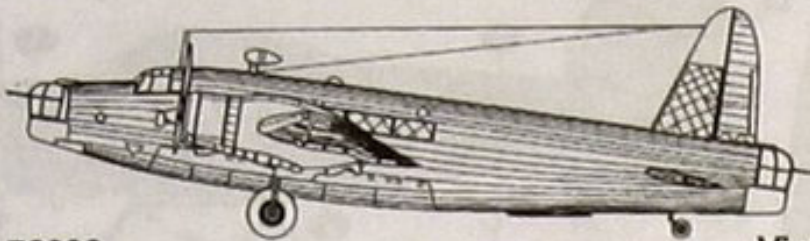

Kit No. 72099

PLASTIKOVÝ MODEL LETOUNU
PLASTIC AIRCRAFT KIT

1/72

Vickers Wellington Mk. IC

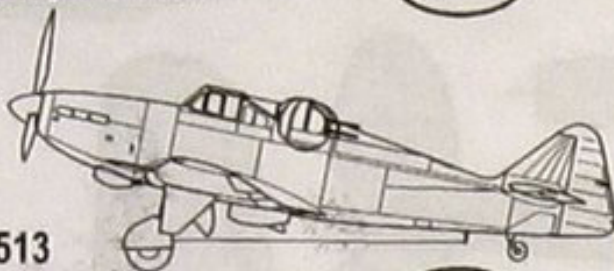

Kit No. 72513

PLASTIKOVÝ MODEL LETOUNU
PLASTIC AIRCRAFT KIT

1/72

Boulton Paul Defiant Mk. I

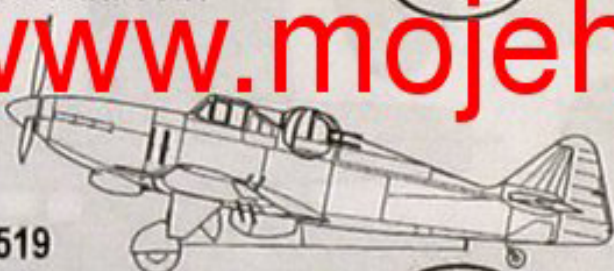

Kit No. 72519

PLASTIKOVÝ MODEL LETOUNU
PLASTIC AIRCRAFT KIT

1/72

Boulton Paul Defiant NF Mk. II



Kit No. 72517

PLASTIKOVÝ MODEL LETOUNU
PLASTIC AIRCRAFT KIT

1/72

Fokker D.XXI 'Dutch defender'



Kit No. 72520

PLASTIKOVÝ MODEL LETOUNU
PLASTIC AIRCRAFT KIT

1/72

Fokker D.XXI 'Suomi 3. sarja'

Více informací a termíny uvedení a kth.
Můžete v modelářských prodejnách
nebo také na internetu

For more information and
actual release date of all items please visit your local dealers
or visit our website!

www.mpm.cz

internetový obchodí MPM on-line shop!
www.mpmshop.cz