

# BRITISH 25 PDR. FIELD GUN & QUAD GUN TRACTOR

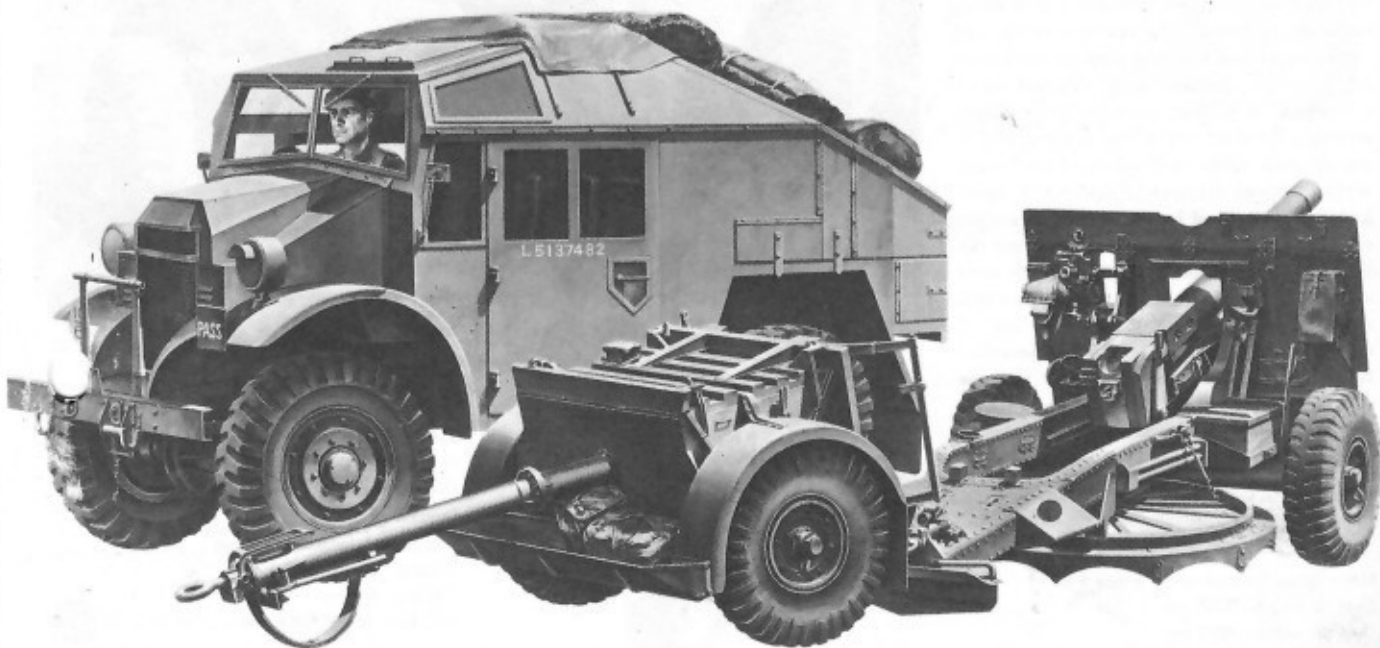

**TAMIYA**  
TAMIYA PLASTIC MODEL CO.  
628, Oshika, Shizuoka-City, Japan

1/35 MILITARY MINIATURES SERIES NO.44



During WW1 with the advent of greater movement than in previous wars and with the continued development of the internal combustion engine many lessons were to be learnt. This was especially true of the artillery arms of the world's armies. The mobile artillery pieces were able to engage rapidly, by day or night and regardless of weather conditions, crucial points spotted by its reconnaissance arms. The specialised disciplines thus developed trained the artillery man to make a rapid overall survey in order to arrange his arcs of fire in the most strategic positions, where like a lever under a load it would be most devastating.

Between the Great Wars many new requests were made by serious minded gunners to improve their effectiveness. However to implement all these requirements would have been too costly and these improvements came necessarily in dribs and drabs. Rapid aiming and firing anti-tank guns were developed. To increase range and limit recoil, muzzle brakes were introduced, with economy in mind horsedrawn artillery was still however retained.

In the late 30's the first field artillery tractors (FAT) or Quads appeared. In 1938 Guy Motors produced the "Quad Ant" 4 wheel-drive FAT. The Morris commercial 8BMK1 followed in 38/39. The "Quad Ant" continued in production till 1943. The chassis was also used in modified form for the Guy Armoured car. The greatest volume of production was in Canada.

Guy Ant  
4X4FAT

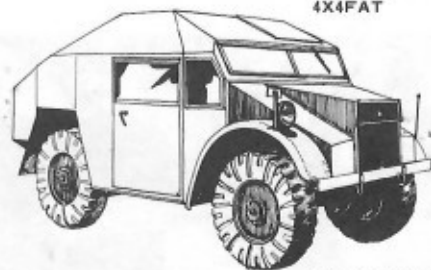

Morris 8BMK II

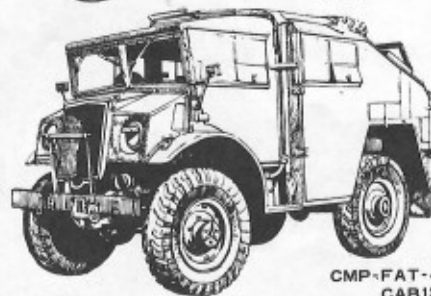
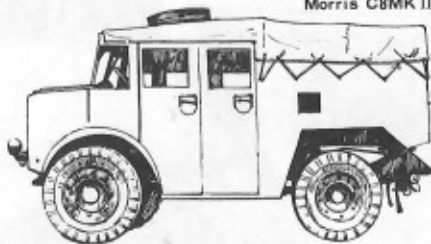

CMP-FAT-4  
CAB13

These FATs were supplied on both Chevrolet & Ford chassis at first of the same pattern as the British type. But from 1942 they were produced with a standard Canadian Military Pattern CAB. Later in 1944 both Morris Commercial and CMP models were produced with a new square contoured body with canvas top. Various companies at various times produced many different variants of these versatile tractors. They were supplied to many countries in differing guises and consequently were widely used throughout the world. Many were sold after hostilities to the Japanese police for riot control. All these vehicles were produced to carry a driver, mate, crew of four and their necessary equipment. Basically these vehicles were built for gun towing and had to have many of the features of their immediate predecessors, the horsedrawn gun carriage teams.

These features were generally the capabilities of good cross country performance high mobility and the means to bring their gun into action very quickly. The guns and limbers generally towed by these FATs were the 18, 20 and more often 25 pounder gun howitzers.

The UK 25 pounder gun howitzer was widely employed by the British Army and was also supplied to many other armies. It first came into service in 1940 and amongst the many honours gained by it and its commanders was the famous and decisive Barrage at Alamein. At this great battle before the break out plans

were made, a total of 850 field guns and sixty medium guns were available to the Eighth Army under General Montgomery. These guns were opposed by 550 field and 30 heavy guns of the combined German & Italian divisions. Of the British guns 408 25 pounds were used in the Barrage and many others held in reserve or mounted on their wheels ready to move off. When in use the gun was usually mounted on a circular firing platform which by moving the trail permitted a 360° traverse. Early versions of this gun appeared without a muzzle brake but later versions were equipped with a multi-baffle muzzle brake. The traverse of the gun when used without the firing platform was limited to 8° and its elevation to 45° this last factor restricting its use in mountainous or jungle terrain. Its great versatility ensures that it was the most widely used and one of the longest serving weapons deployed by the British Army. It was first designed by the British armaments research and development establishment and the first proto type appeared in 1935. Trials were made during 1935/36 and this weapon was still standard equipment with the British Army of the Rhine until replaced by the self propelled 105mm Abbot. The limber used with this gun was used to carry ammunition, the firing platform and other equipment that could not be fitted in or onto the Quad.

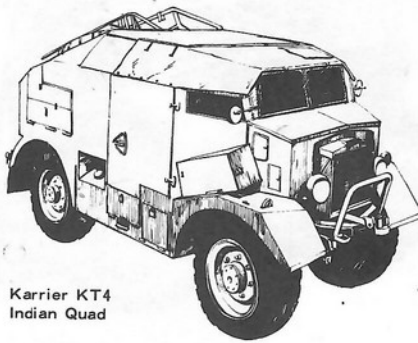

Karrier KT4  
Indian Quad

Engine: Ford V-8 side valve water cooled  
gasoline, 85 hp  
Transmission: 4 forward 1 reverse

**25Pdr. Field Gun**

Overall length: 4646 mm  
Overall width: 2133 mm  
Overall height: 1701 mm  
Gun barrel length: 2476 mm  
Weight: 1741.8 kg  
Calibre: 88 mm  
Shooting range: 12.3 km

**Main Specifications of Ford FAT-2**

Overall length: 4331 mm  
Overall width: 2235 mm  
Overall height: 2286 mm  
Wheel base: 2572 mm  
Weight: 3996 kg



<Construction of Quad Gun Tractor>



This kit is a combination kit of British 25 Pdr. Gun and its tractor, Quad. You can enjoy assembling of two fine models in one kit. Start your assembly work whichever one you prefer and follow respective instructions.

- ★You will need a sharp knife, a pair of tweezers, a file, and a pair of pliers.
- ★Do not break parts away from sprue, but cut off carefully with a pair of pliers.
- ★Use glue sparingly. Use only enough to make a good bond. Apply cement to both parts to be joined.

1 Construction of Drive Shaft

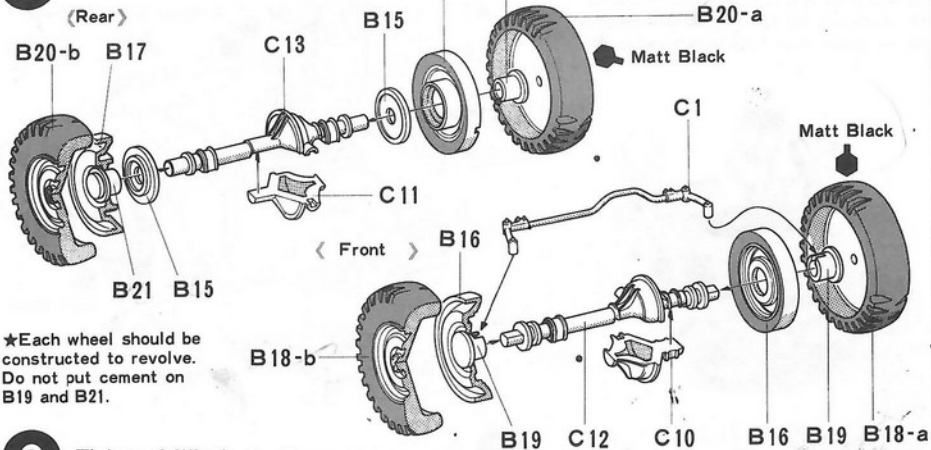

2 Fixing of Winch

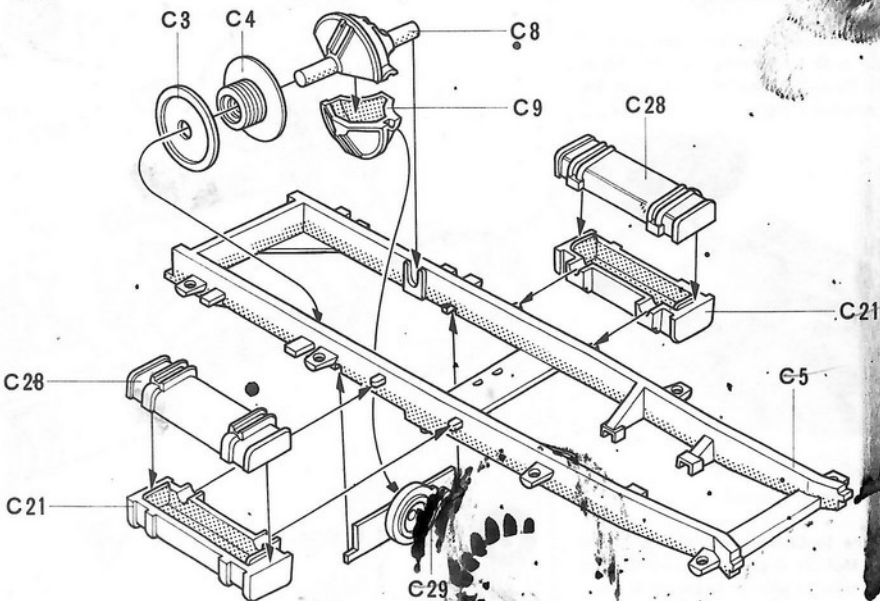

3 Fixing of Transfer Case

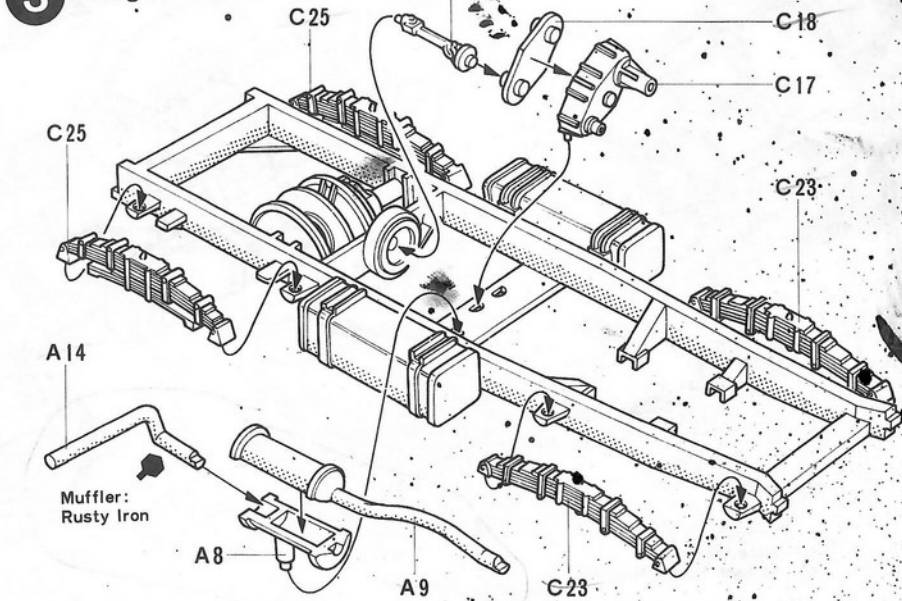

1 <Construction of Drive Shaft>

Turns B18 and B20 should be fixed in relative positions as shown in the photo.

2 <Fixing of Winch>

Winch Wheels C3 and C4 should be free to revolve. Do not put too much adhesive on them. Cement part C29 to Chassis before fixing C9 and C8.

3 <Fixing of Transfer Case>

Cement Transfer Case and Front and Rear Springs. Construct Muffler with Parts A8, A9 and A14. Muffler may be glued after Engine is fixed in ④.

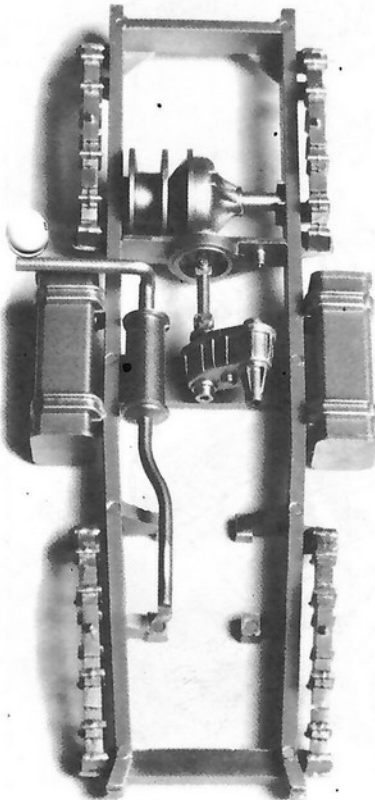



#### 4 (Construction of Engine)

Construct Engine Block by gluing A13 and A16 together. Then, fix necessary parts. Exhaust Pipe A10 is to be glued to Muffler A9 which will be fixed in ⑤, and so A10 may be glued after Engine is fixed in ⑥.

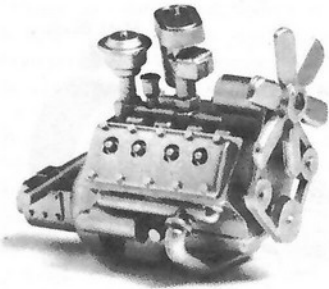

#### 4 Construction of Engine

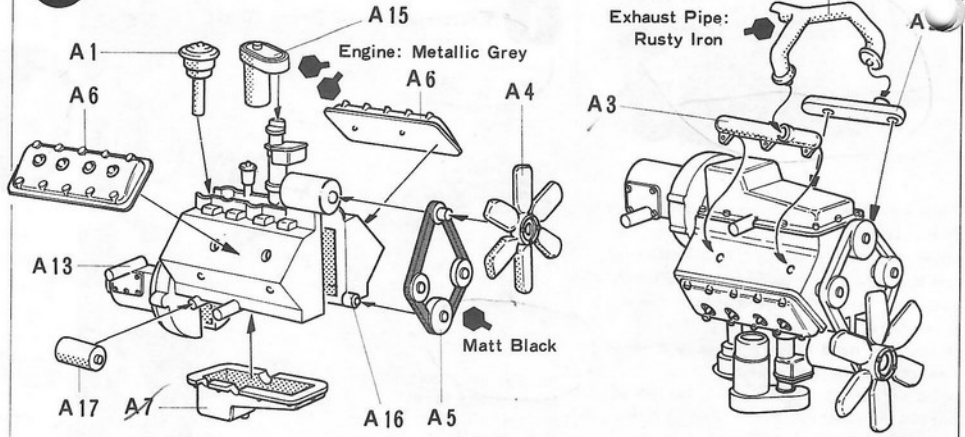

#### 5 (Fixing of Drive Shaft)

Cement Front and Rear Differentials constructed in ① to Springs. At the same time, fix Propeller Shaft. This must be set at a correct angle.

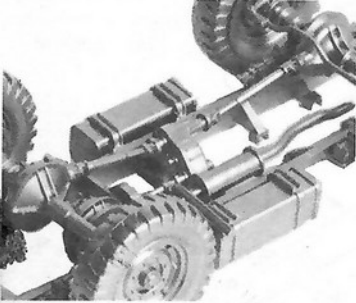

#### 5 Fixing of Drive Shaft

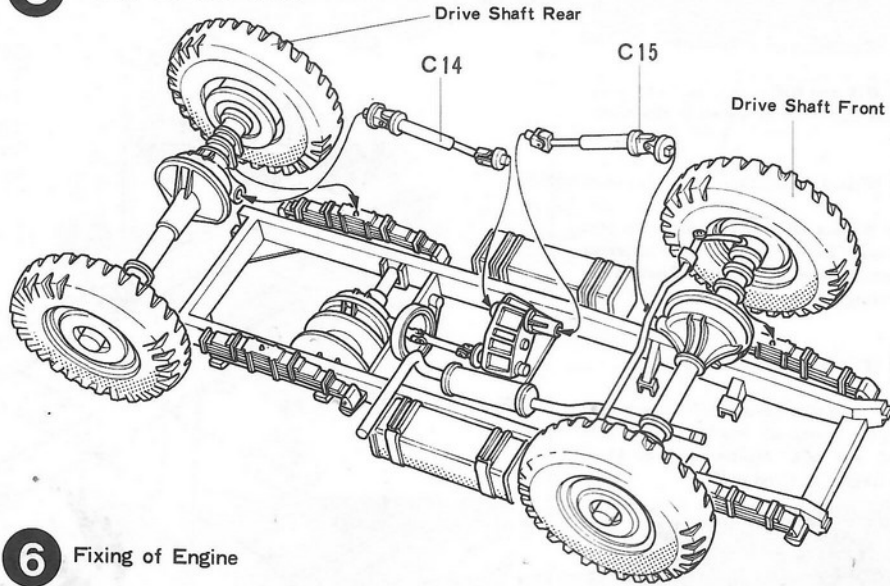

#### 6 (Fixing of Engine)

Fix Engine to Chassis and glue Exhaust Pipe and Muffler in place. Cement Spring Part C19 using a pair of tweezers or the like.

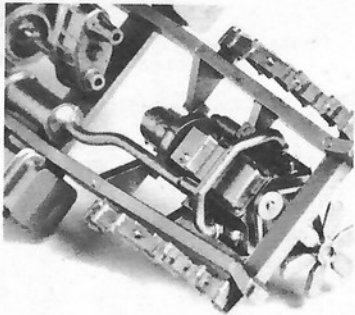

#### 6 Fixing of Engine

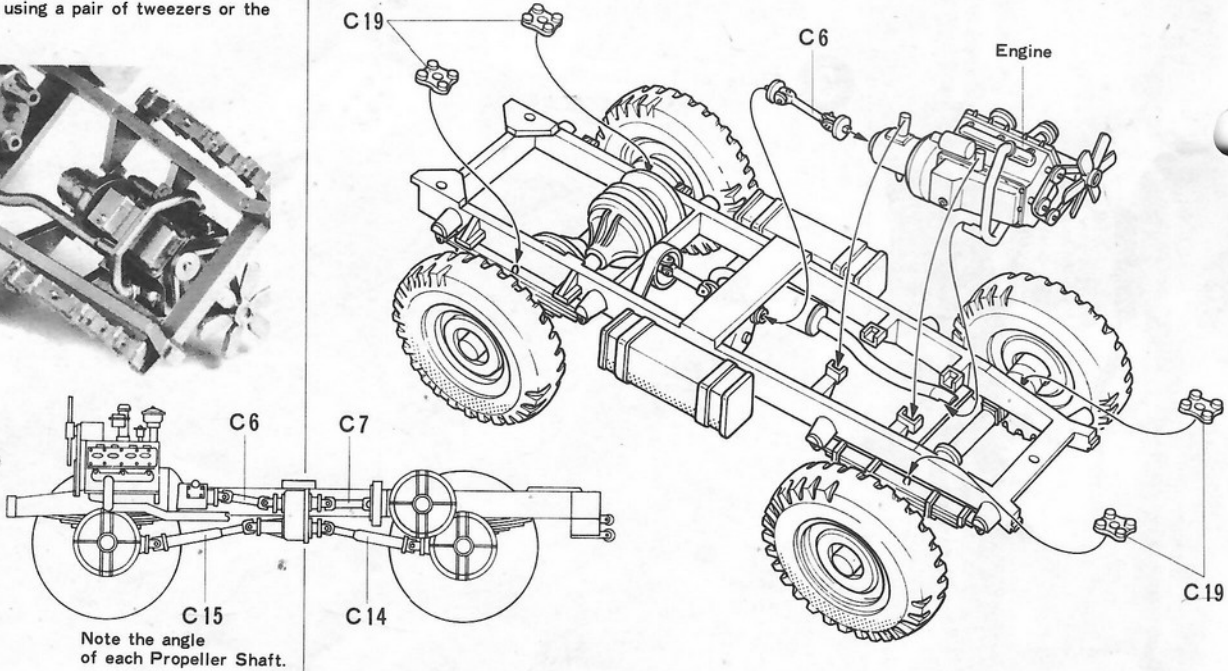

**7** (Fixing of Front Bumper)

Mount Radiator Protector C2 to Front Bumper. Then, fix Front Bumper to Chassis.

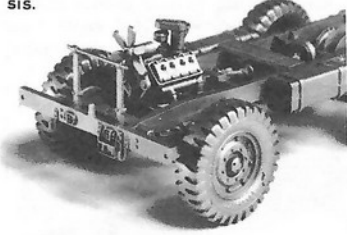

(Fixing of Winch Roller)

Construct Winch Roller with parts C16, C22, C24 and C27. Then, fix Winch Roller to Chassis.

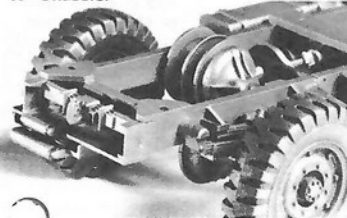

**8** (Fixing of Seats)

Six Seats of the same shape should be constructed in all. Rear Seats must be fixed after parts A11 and A12 are glued in place.

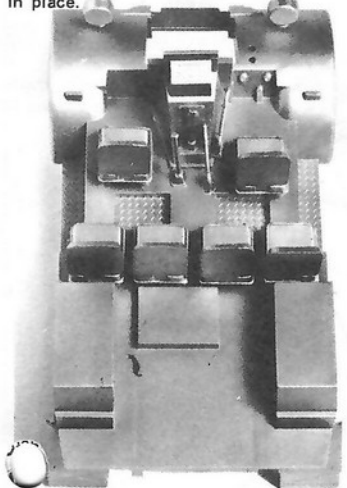

**9** (Fixing of Windscreen)

Windscreen should be fixed in place after A28 is glued to Body and must be glued after Body is painted.

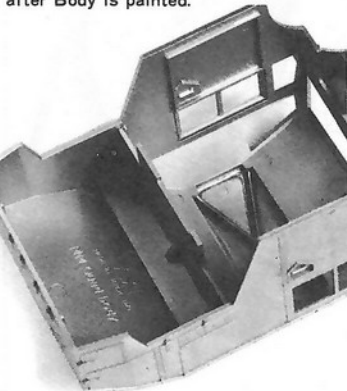

**7** Fixing of Front Bumper

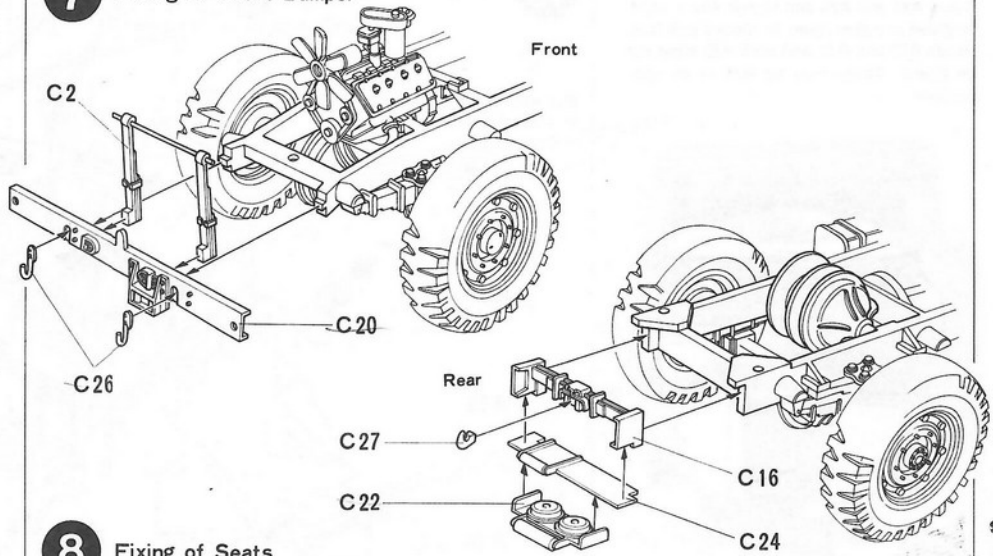

**8** Fixing of Seats

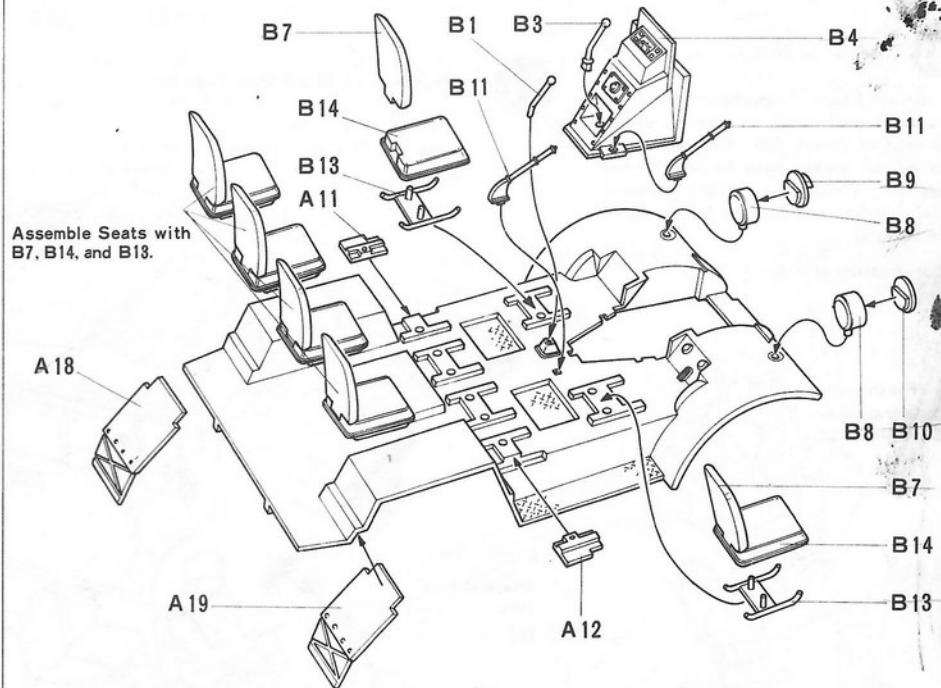

**9** Fixing of Windscreen

Fix Windscreen after you finish painting of Windscreen surroundings.

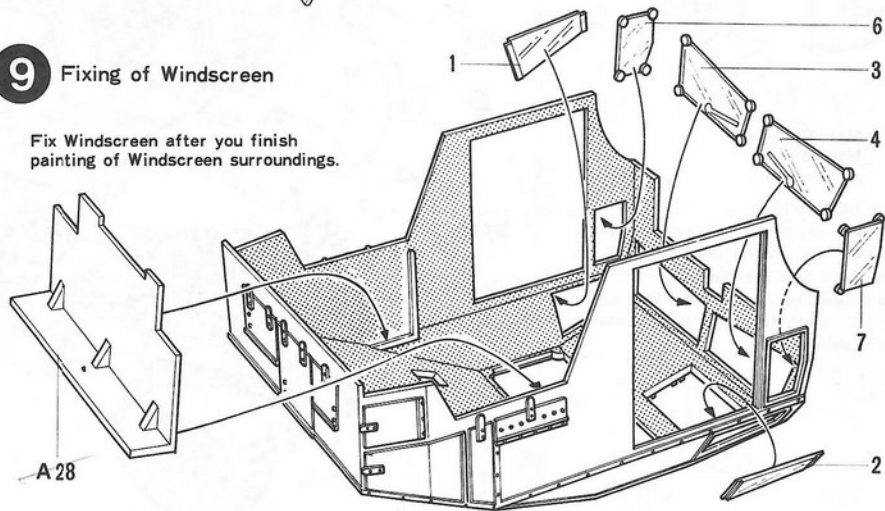

### 10 (Fixing of Body Parts)

Doors A24 and A25 and Hatch A22 should be glued in either open or closed position. Hoods A20 and A21 and part A23 need not be glued. These may be left in an open position.

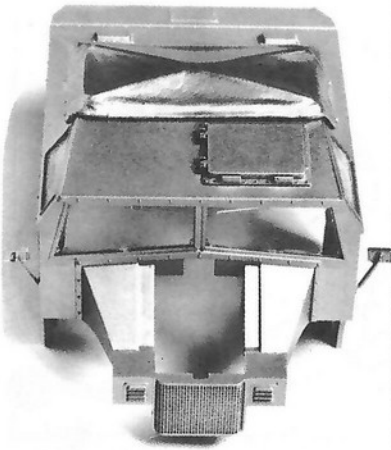

### 10 Fixing of Body Parts

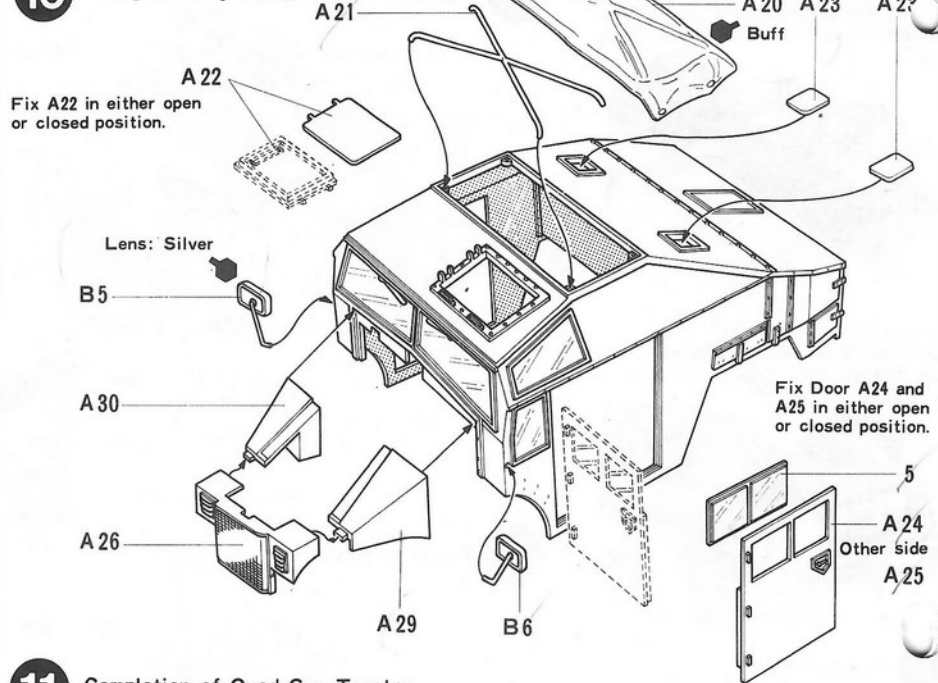

### 11 (Completion of Quad Gun Tractor)

Construct figure. Then, cement onto Drivers Seat with hands on steering wheel. Do not glue Bonnet A27. Body and Chassis do not always have to be cemented together. These may be displayed separately so that you can see the inside of the vehicle.

#### (Construction of Figure)



### 11 Completion of Quad Gun Tractor

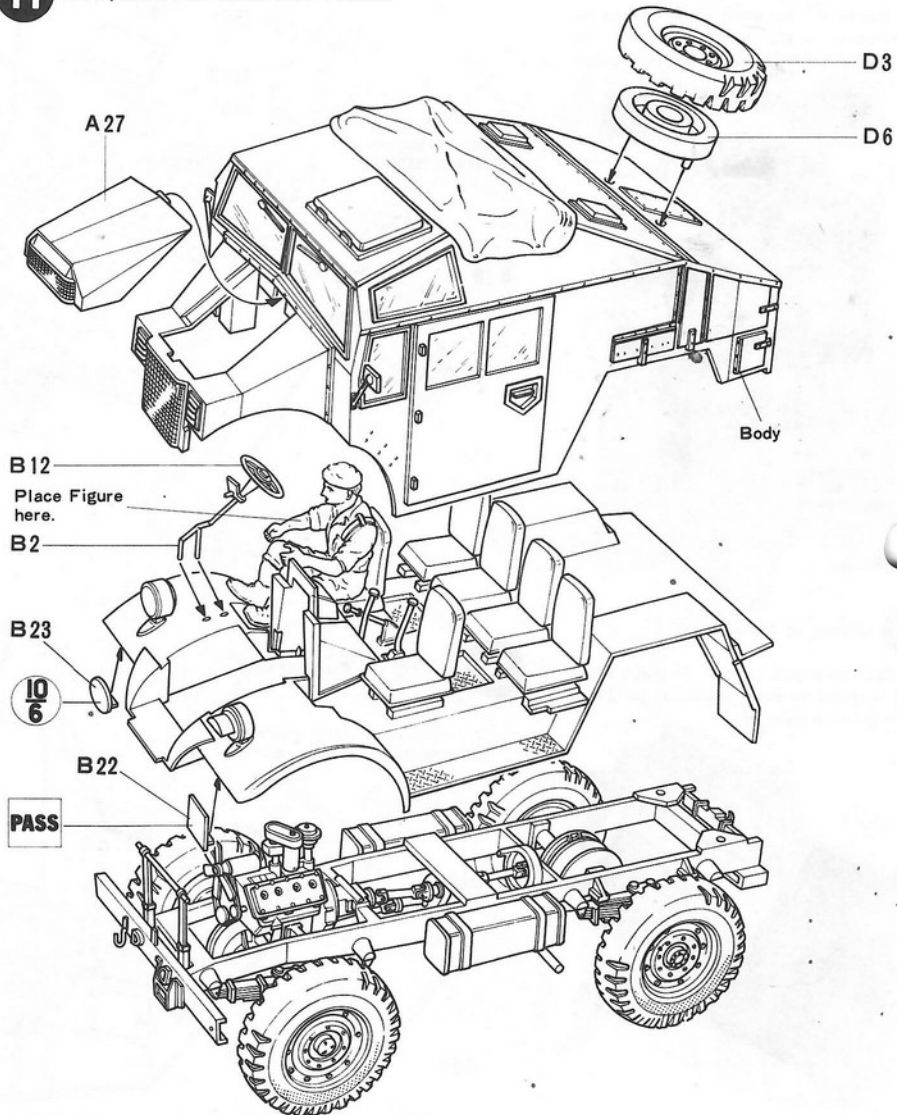

#### (Knack of Painting)

The Quad was painted dark yellow overall. Reproduce rust marks, mud, dirt, etc. on the body to lend realism to the vehicle. Use a solution of thinner and a very small amount of black to reproduce oil stains on differentials, etc.



1 (Construction of Gun Body)

Assemble Gun Body Halves X5 and X6, Breech Mechanism Halves X21 and X22. And then cement both of them together. Breech Block X28 is movable. Insert this into Breech Mechanism without glue.

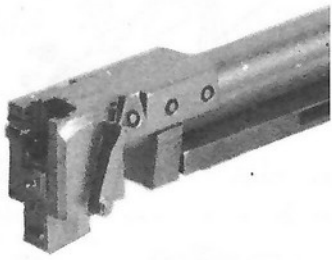

2 (Fixing of Cradle)

Cement Cradle Halves X32 and X33 together, while making Gun Body slide smoothly between them. Muzzle Brake was attached to the later version of 25 Pdr. Gun. And part X55 is prepared for the early one. Select either one and fix.

3 (Construction of Trail)

Cement Trail Halves X38 and X39 together and fix Top Plate X19. You will get perfect fit if you file their areas to be joined together.

4 (Completion of Trail)

Cement Handles X47 and X48 to Spade X37 and fix to Trail Body.

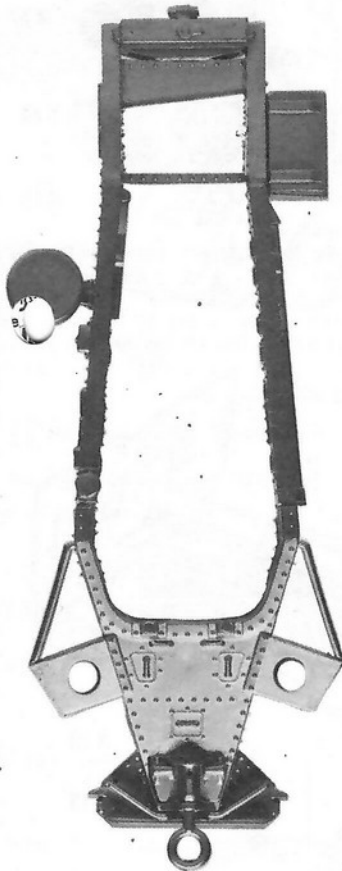

(Construction of 25 Pdr. Gun and Limber Carrier)

1 (Construction of Gun Body)

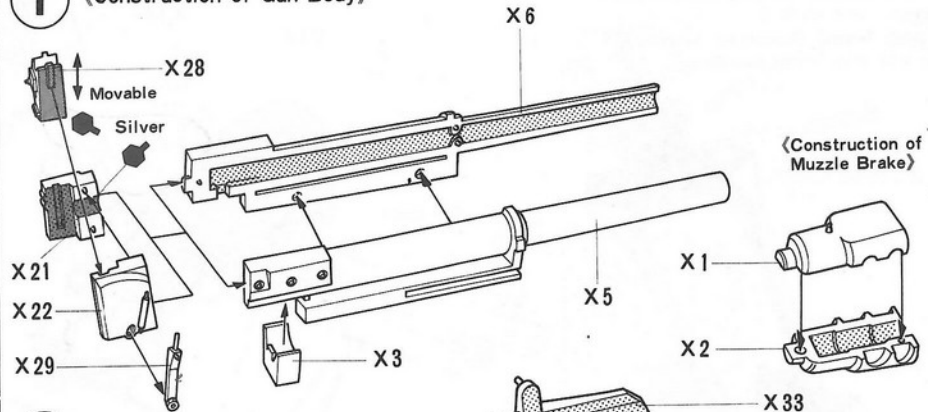

2 Fixing of Cradle

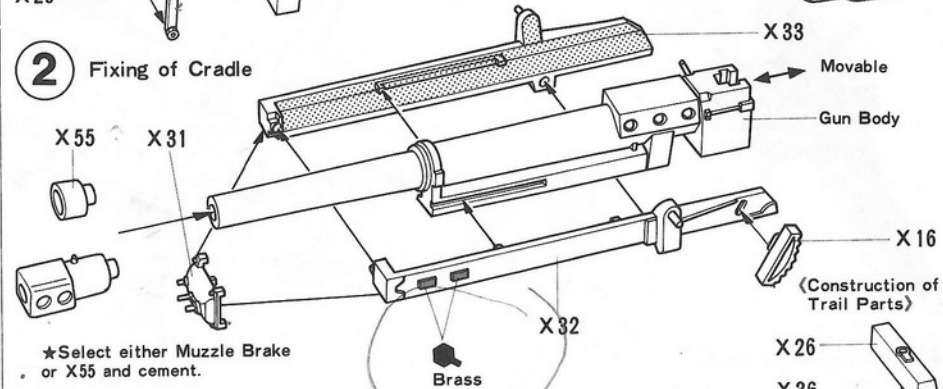

3 Construction of Trail

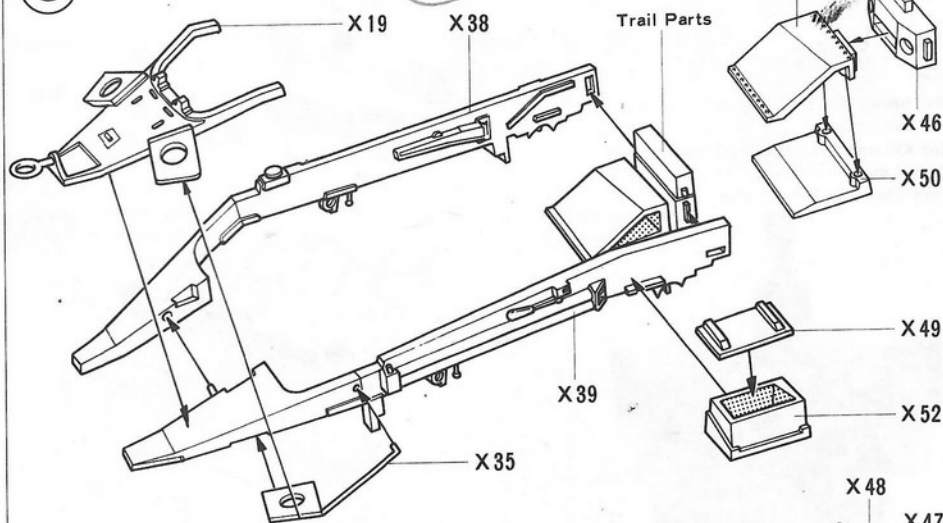

4 Completion of Trail

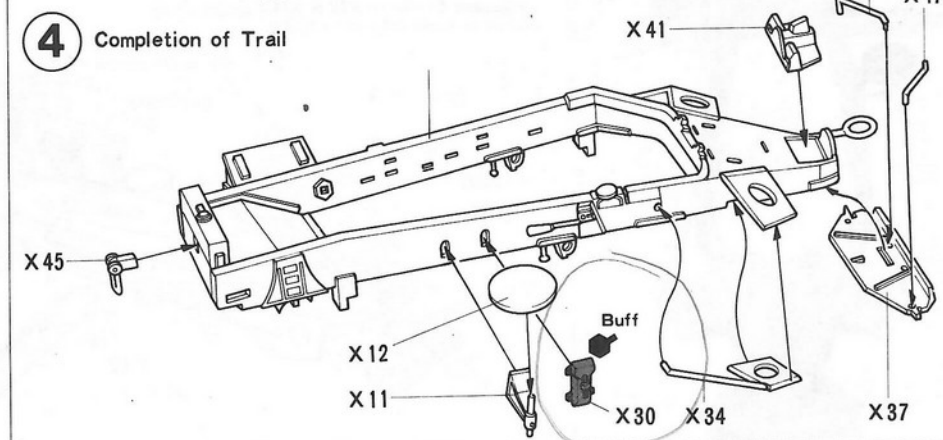

**5** (Fixing of Gun Body)

When you construct Left Saddle, make sure of numbers and positions of various parts.  
Cement Shield Supporting Stays X13 and X14 after fixing Gun Body.



**5** Fixing of Gun Body

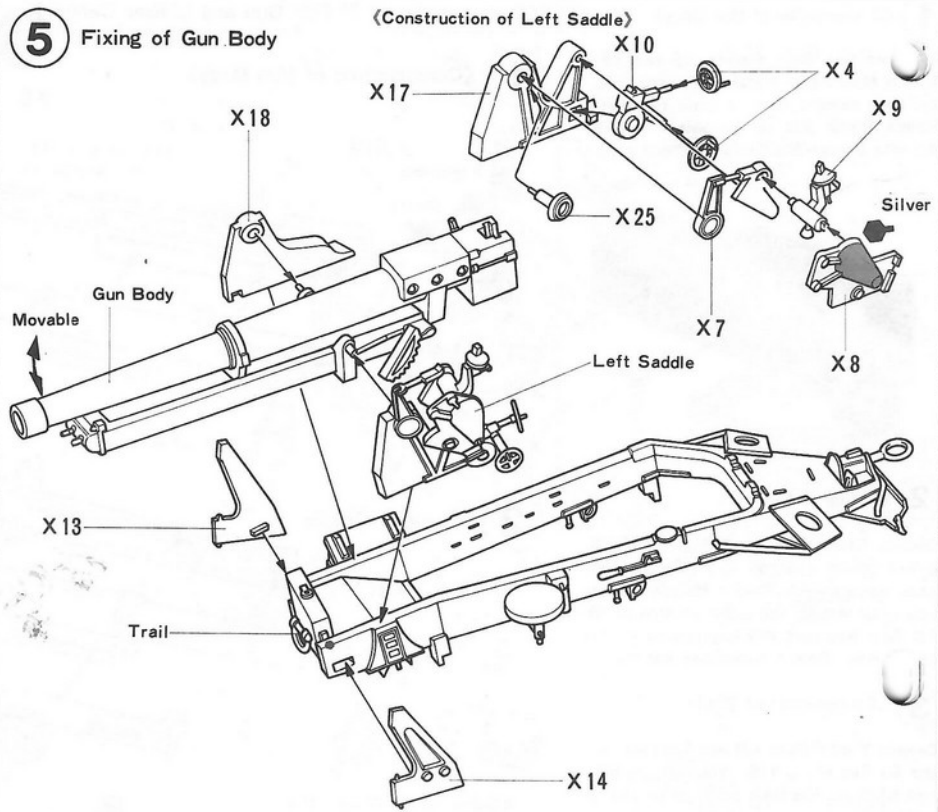

**6** (Construction of Shield)

Fix various parts to respective sides of Shield X15.

**7** (Fixing of Shield)

Fix Shield to Shield Supporting Stays X13 and X14.  
Rod X56 was used to change the direction of the gun when firing. If you wish to make the firing gun fix this.

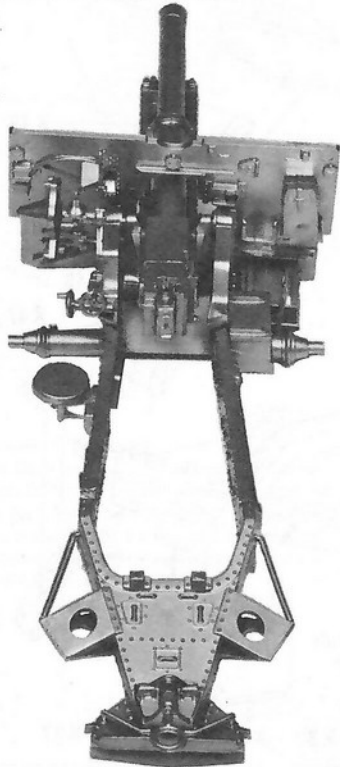

**6** Construction of Shield

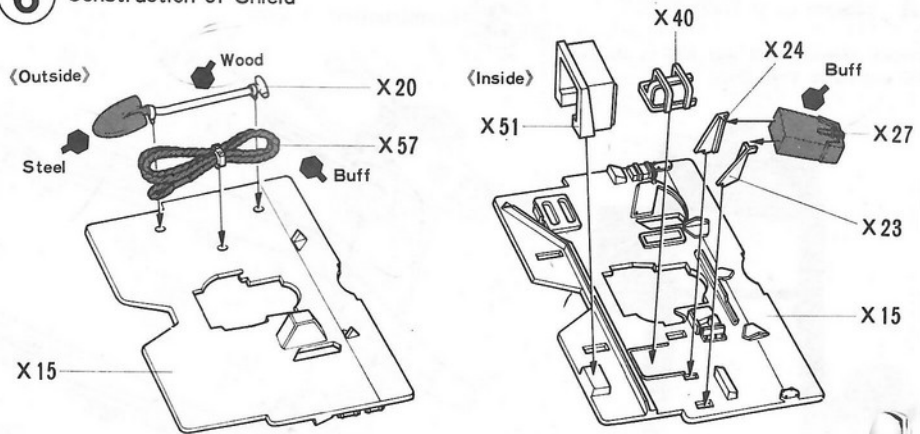

**7** Fixing of Shield

★Cement Shield to X13 & X14.  
★X56 is fixed only when firing.

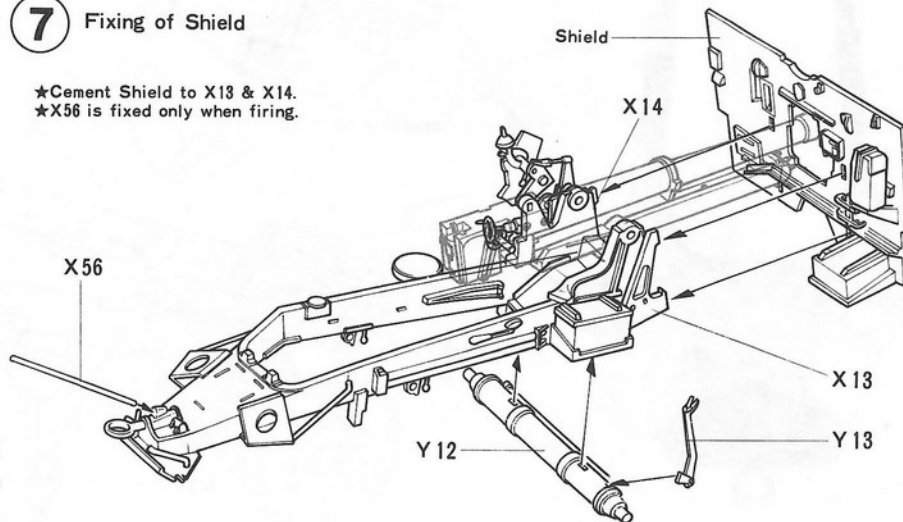



**8** Construction of Wheels and Firing Platform

Make four sets of Wheels, two for Gun and two for Limber Carrier. Firing Platform can be constructed into either transporting or firing position. Select one you prefer and assemble. This part was fixed to make the gun traverse quickly.

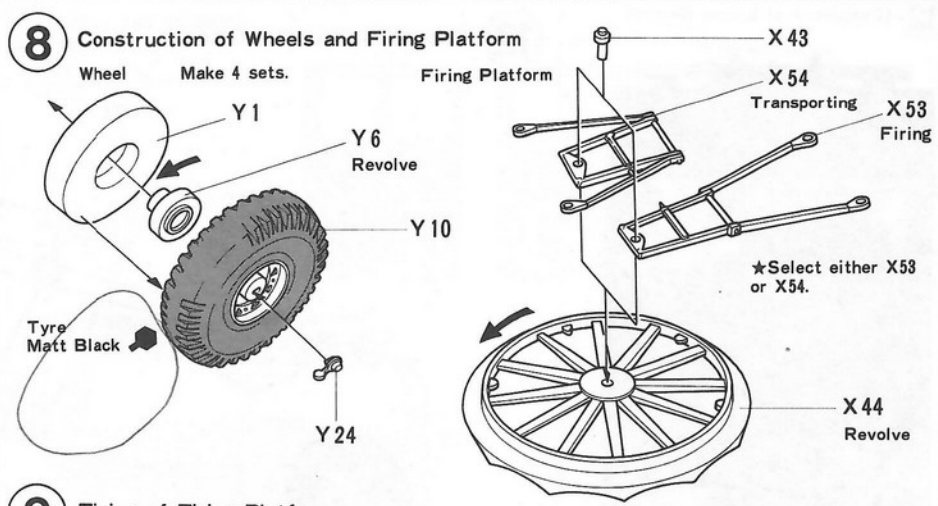

**9** Fixing of Firing Platform

Photos below show transporting and firing positions.

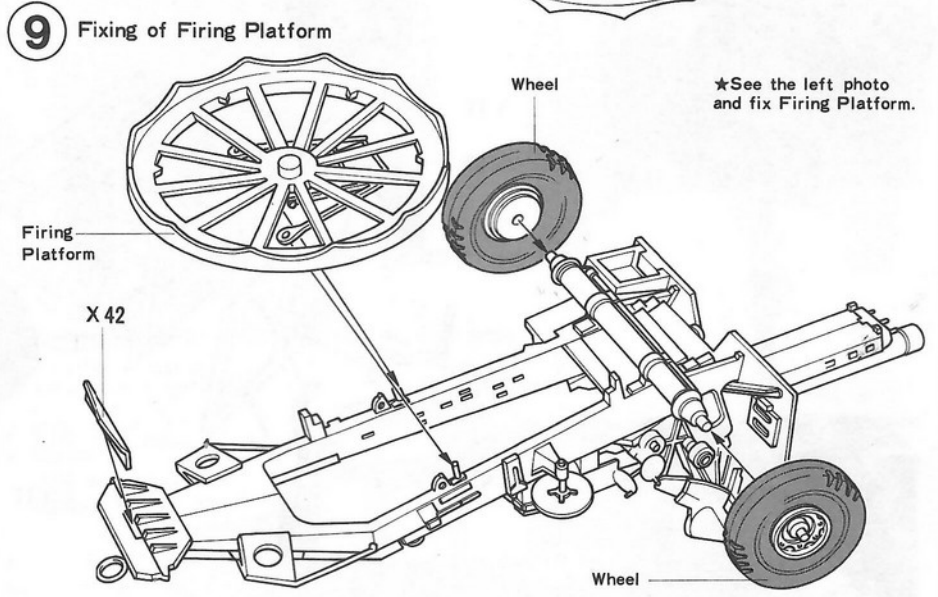
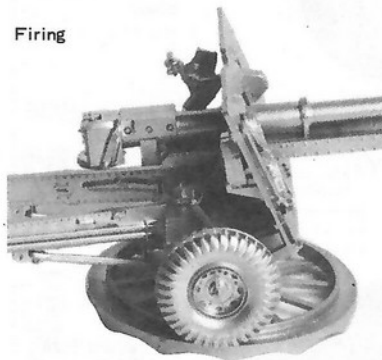
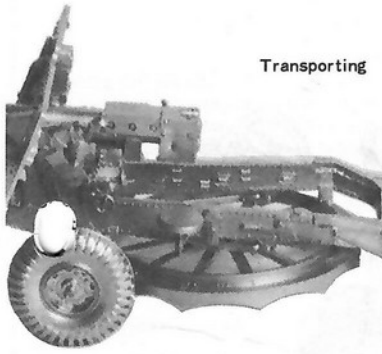

**10** Construction of Limber Carrier Parts

Choose either Y3 or Y4, Y2 or Y5 and cement them. Y2 and Y3 are for transporting position, and Y4 and Y5 are for firing.

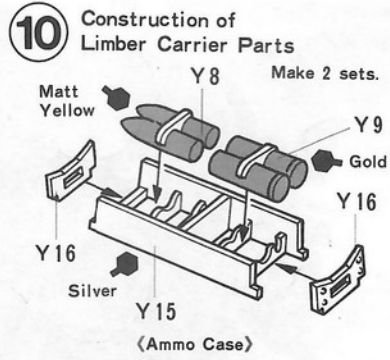

**11** Construction of Limber Carrier

**11** Construction of Limber Carrier

Cement Y20 before fixing Y27 to Y30. (Fixing of Fenders)

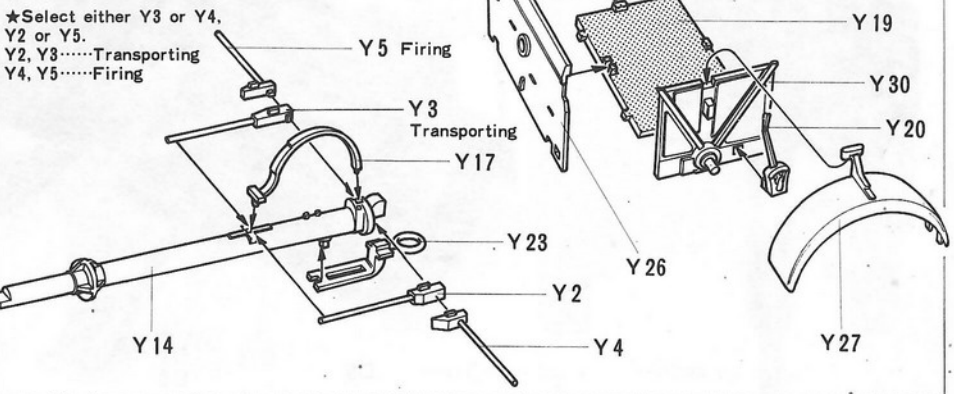
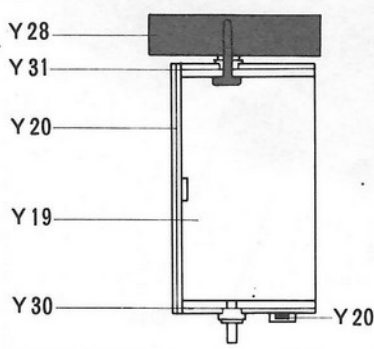

12 (Completion of Limber Carrier)

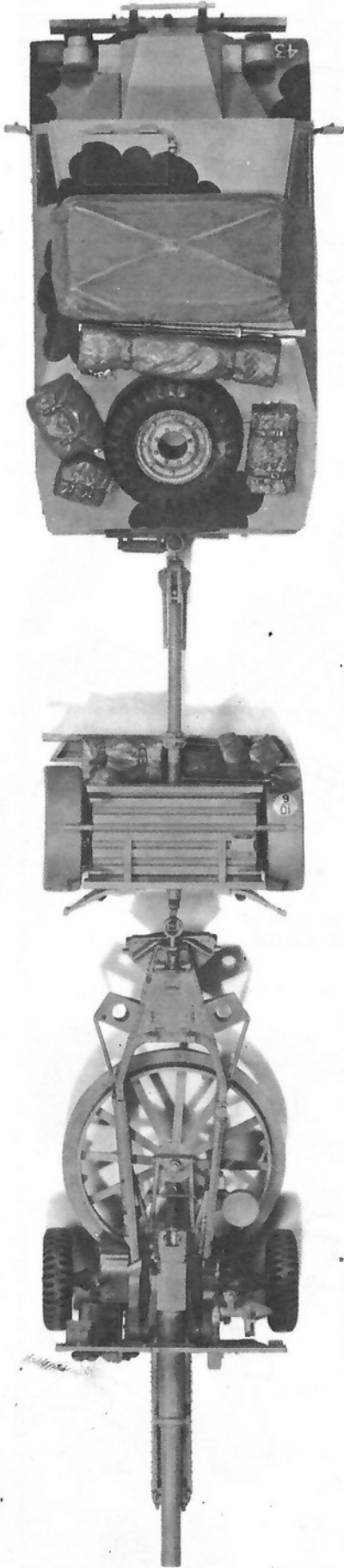

12 Completion of Limber Carrier

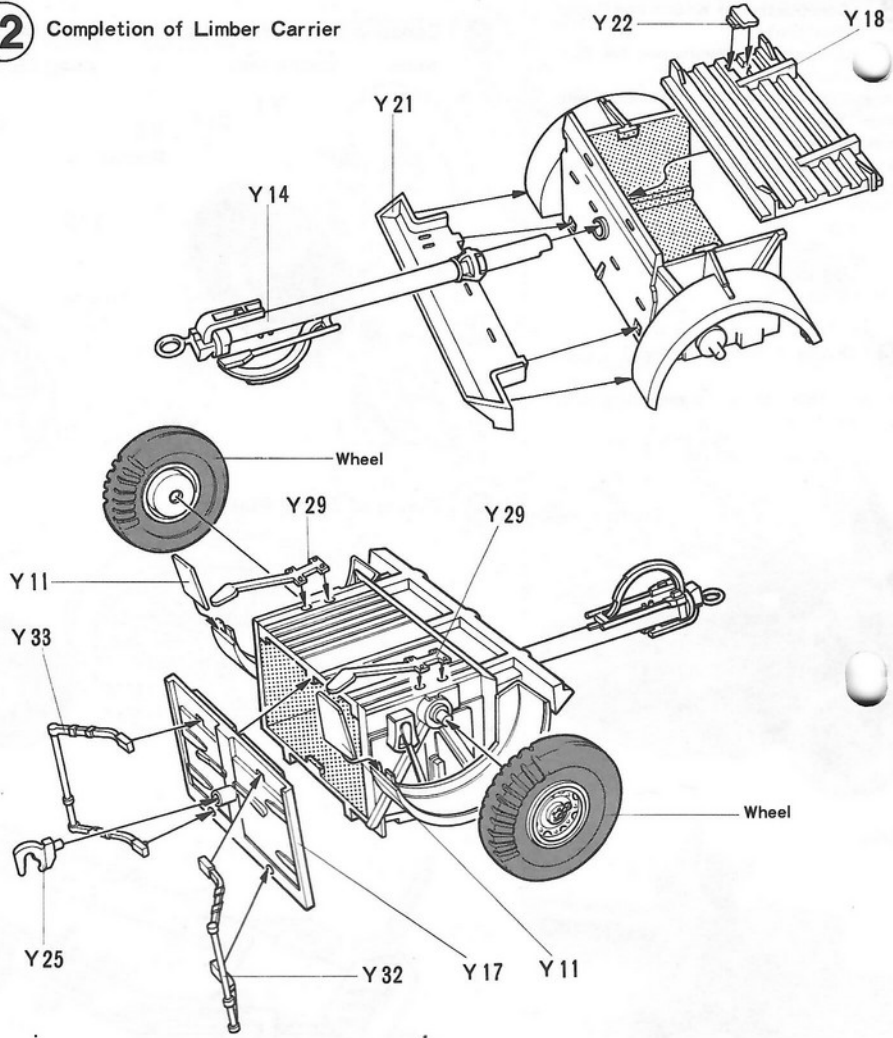

(Fixing of Accessory Parts)

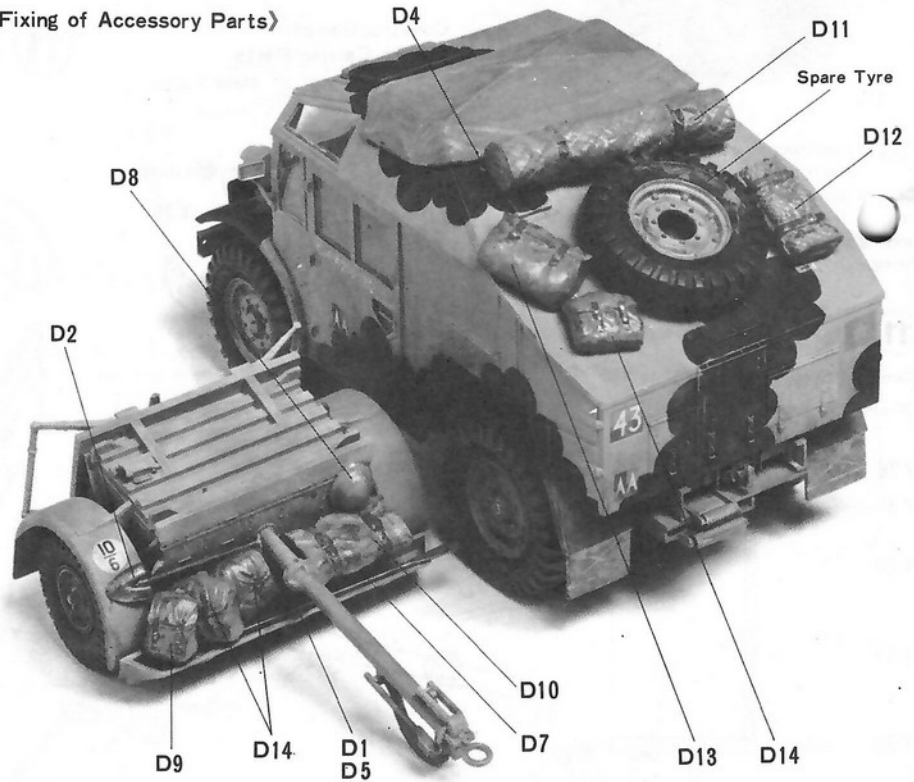

**PAINTING**

**APPLYING DECALS**

**Painting of Quad**

Military vehicles including the Quad were camouflaged to match the terrain. They then blended into the surroundings in order to conceal them from the enemy. Quads used by the British in Africa often wore black or dark green Mickey Mouse pattern (pattern shaped like Mickey Mouse's ears) over the dark yellow body. Quads used by the Canadians were painted dark green overall.

**Marking of Quad**

Quads incorporated into the British forces in North Africa and those of the Canadian forces in Europe wore marking as follows:

**Canadian Army Marking**

 Organization sign representing the organization to which the vehicle is belonged.

**43** Arm-of-service mark.

**AA** Tactical mark

**British Army Marking**

 **A1** Brigade mark used by the Eighth Army. This was worn by the famous "Desert Rats" which rendered distinguished service in the African theatre of war. "A1" and "A2" mean the 1st and 2nd vehicle of the A Company respectively.

(1)  **74** Combination of a tactical mark (upper) and an arm-of-service mark (lower). This shows that (1) is the commander's vehicle of the 1st Battalion in the Field Artillery Regiment and (2) is that of the 2nd Battalion in the Regiment.

**Other Marks**

 Bridging classification mark representing the vehicle's limit weight in crossing a bridge. "6" is the bridging classification number of the vehicle itself. "IO" is that of the vehicle when towing a 25-pounder.

**PASS** Certificate giving the vehicle permission to pass freely.

**14WD** **14W10** Convoy number of the vehicle written in chalk.

**Vehicle number**

(L →) British Army  
(CH →) Canadian Army

**Canadian 1st Infantry Division**

 Dark Green

Right Door

Left Door

**43**

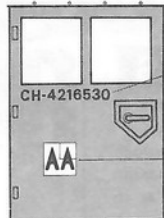
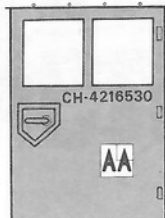

CH-4216530

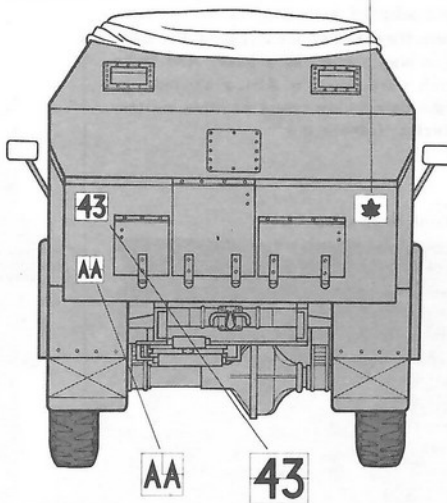
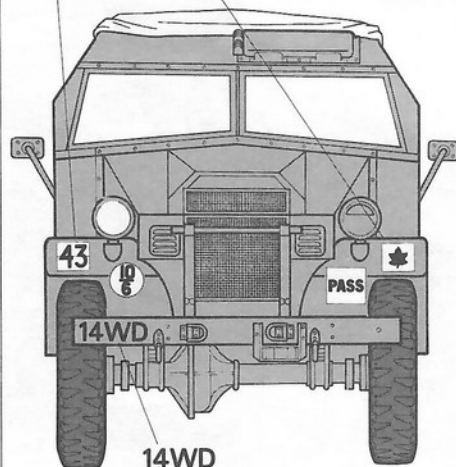

**Commanders Vehicle Used by British 8th Army**

Mickey Mouse pattern was also painted on top of hull.

 Dark Yellow

 Matt Black or Dark Green

L 5137482  
L 2918302

Select either one of two.

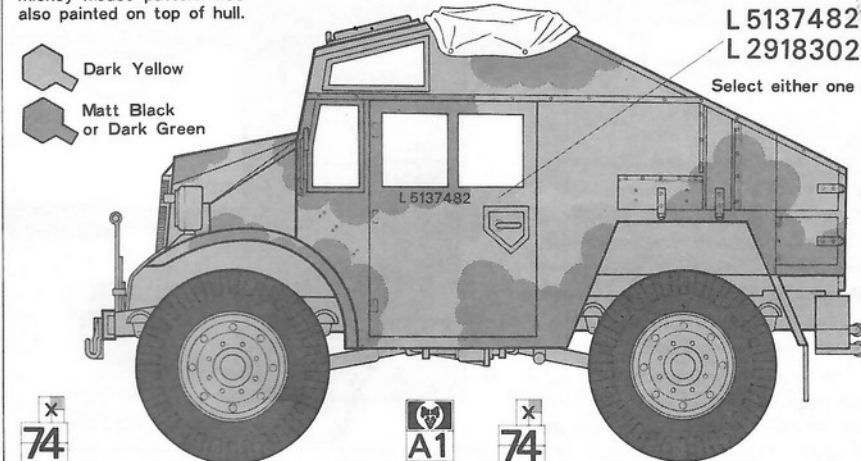

 **74**

 **A1**

 **74**

 **A1**

 **74**

 **A2**

 **74**

 **A2**

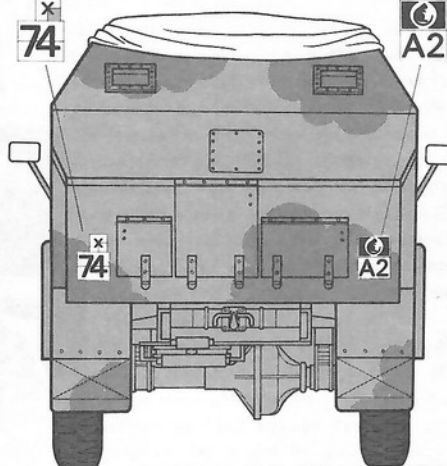
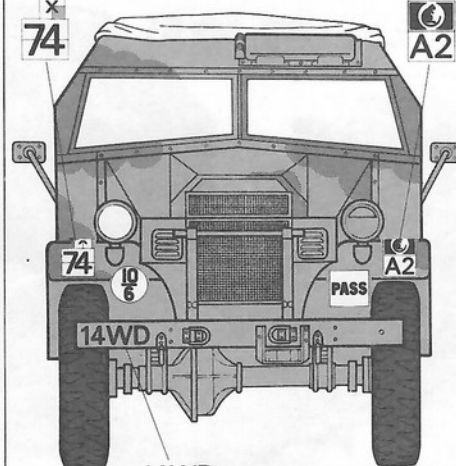

**14WD** **14W10** Either one

Select either one of two markings and apply.



# PAINTING



# APPLYING DECALS

## <Painting of 25 Pdr. Gun>

British 25 Pdr. Guns had been used through a long period, from the German Invasion to France in 1940 to the Korean War in 1950. Though various painting schemes were adopted according to the terrain where they showed activity, generally dark green was applied as a base. And those which were used in Africa carried a single dark yellow colour as other military vehicles in there did.

## <Paint to be used>

It might be convenient to use spray-type paint or air-brush in painting wider areas. When you paint details and small parts, use paint brush and brush-type paint.

The following colours are recommended to paint your 25 Pdr. Gun model.

- Matt Black
- Matt White
- Matt Red
- Steel
- Dark Yellow (British)
- Dark Green
- Silver
- Brass
- Gold
- Matt Yellow
- Silver

★Detail paintings are indicated in the construction figures.

## <Painting of 25 Pdr. Gun>

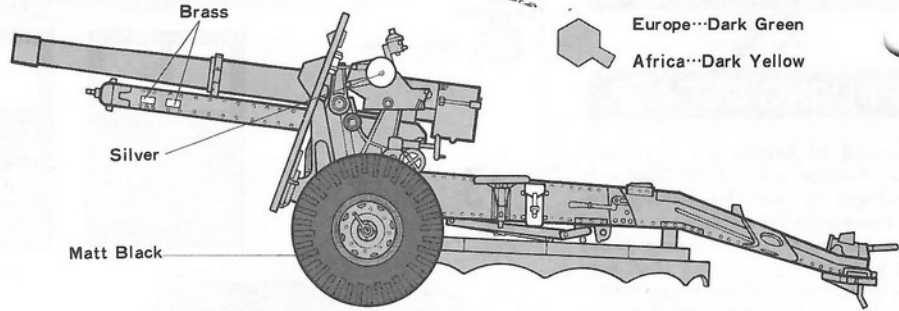

Europe...Dark Green

Africa...Dark Yellow

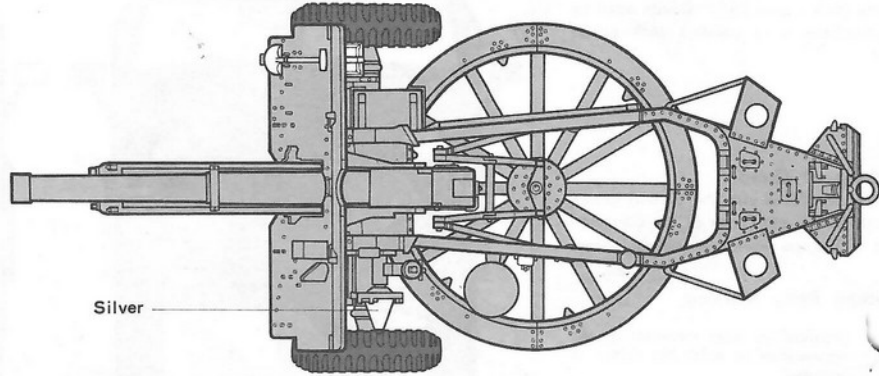

## <Painting of Limber Carrier>

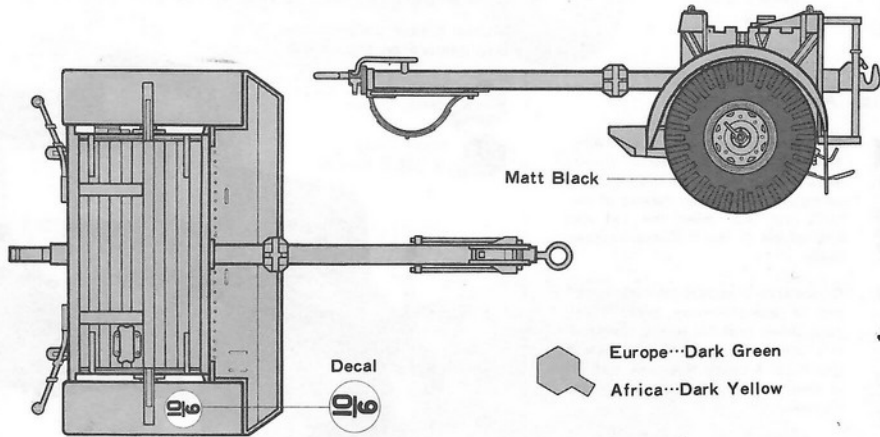

Europe...Dark Green

Africa...Dark Yellow

