

MODEL ALLIANCE

LIMITED EDITION DECALS

TIGER - TIGER

NATO TIGER MEET 06

SPANISH AIR FORCE MIRAGE F.1
& FRENCH AIR FORCE RAFALE B

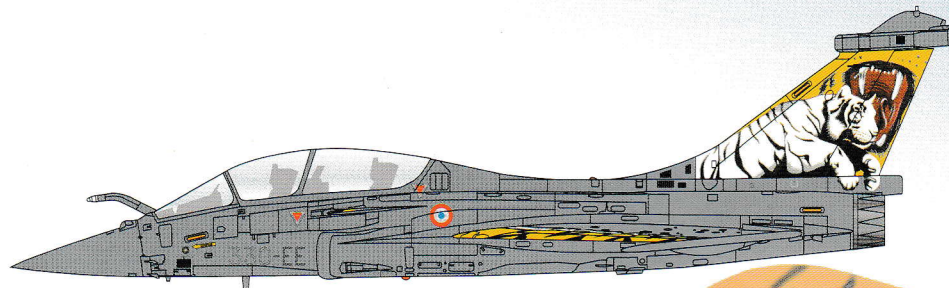

Aviation Workshop
Publications Ltd



SHEET No
MAS-729030
MAS-489030

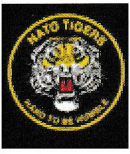

NATO Tiger Meet 06

Dassault Mirage F.1M

Ejército del Aire (Spanish Air Force)

Recommended Mirage F.1M Kits:

1/72 Scale - Hasegawa, Heller or Eschi (Italeri)
1/48 Scale - Italeri

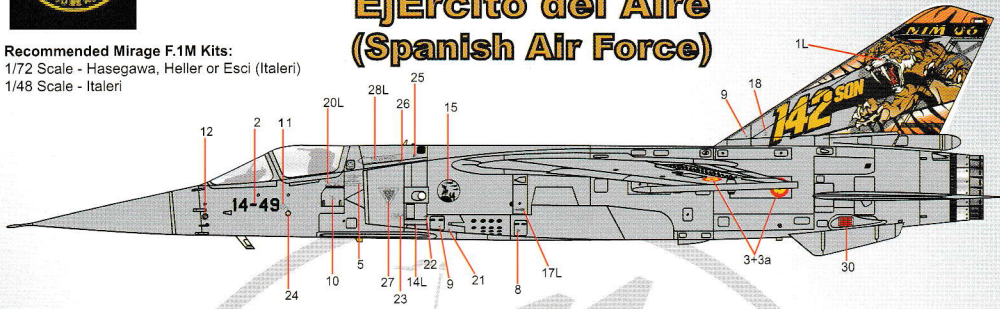

Dassault Mirage F.1M, C14-49 of Ala 14,142 Escuadrón, NATO Tiger Meet 2006
'Special Tiger Scheme' held at Los Llanos Air Base, Albetete, Spain during October 2006.
Ala 14 is home based at Los Llanos Air Base.
Overall Light Grey FS 26473

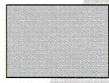
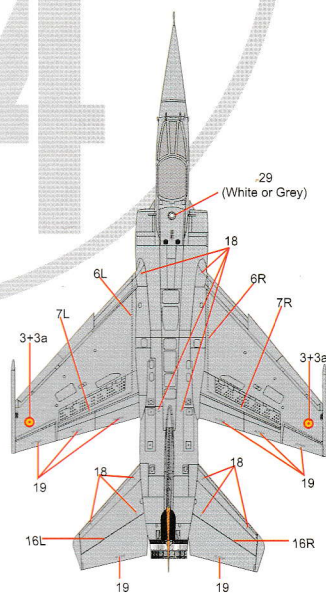
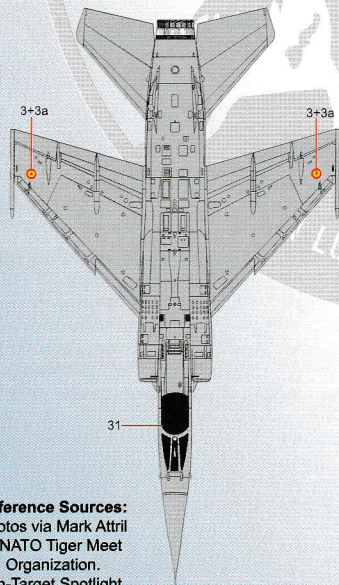
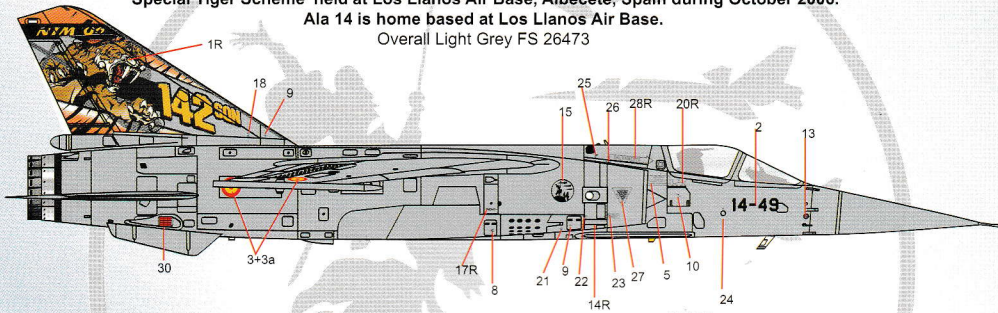

**Light Grey
(FS26473)**
Humbrol 146
Xtracolour X138
Lifecolor UA041



Exhaust/Burnt Metal
Humbrol 27004-7
Xtracolour X504
Lifecolor LC76



Aluminium
Humbrol 27003-0
Xtracolour X500
Lifecolor LC74
ModelMaster 1790

Reference Sources:
Photos via Mark Attril
& NATO Tiger Meet
Organization.
On-Target Spotlight
No 1 - Mirage F.1

NATO Tiger Meet 06

Dassault Rafale B

ArmÉE de l'Air (French Air Force)

Dassault Rafale B, 330-EE (Serial 307) of EC05-330 'Côte d'Argent', NATO Tiger Meet 2006
'Special Tiger Scheme' held at Los Llanos Air Base, Albacete, Spain during October 2006.
EC-05-330 is normally based at Mont de Marsan Air Base.

Overall Celomer 1620 Gris/Bleu-vert moyen fonc.
(Dark Medium Blue Grey)

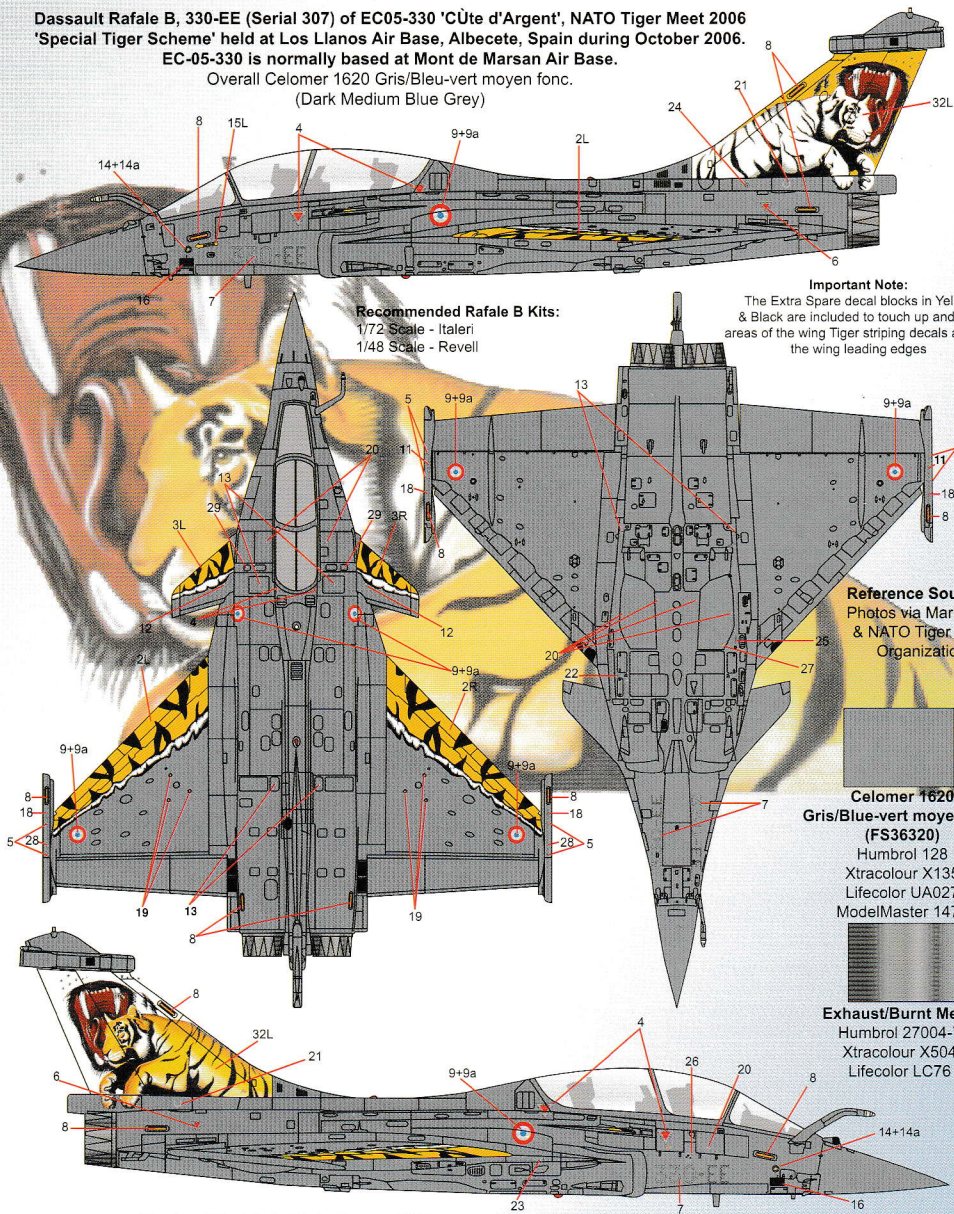

Recommended Rafale B Kits:
1/72 Scale - Italeri
1/48 Scale - Revell

Important Note:
The Extra Spare decal blocks in Yellow & Black are included to touch up and tidy areas of the wing Tiger striping decals around the wing leading edges

Reference Sources:
Photos via Mark Attrill
& NATO Tiger Meet
Organization

Celomer 1620
Gris/Blue-vert moyen fonc
(FS36320)
Humbrol 128
Xtracolour X135
Lifecolor UA027
ModelMaster 1470

Exhaust/Burnt Metal
Humbrol 27004-7
Xtracolour X504
Lifecolor LC76

Artwork and Decal Design By Jon Freeman 2006
© Jon Freeman &
The Aviation Workshop Publications Ltd
2006



Model Alliance Decals - UK & The Aviation Workshop are trading names of The Aviation Workshop Publications Ltd & Gary Madgwick. The On-Target Publications, AIRframe Journal, Spot-Lights & Conflict /AirWars are all names registered to The Aviation Workshop Publications Ltd and may not be used without the permission in writing of the The Aviation Workshop Publications Ltd. These decals and all artwork are copyright The Aviation Workshop Publications Ltd and Jon Freeman 2005.

Decals Instructions:

These decals are a high quality product produced for Model Alliance Decals - UK by Colourslide. The decals are very thin but very strong and flexible.

1. Before painting the model, clean with 'Model Wipes'. This cleans the grease and any dust from the surface.
2. We recommend that you wear 'Model Gloves' to handle the model whilst preparing it for painting.
3. For best results, spray the model with a Light Grey primer, any defects can then be made good.
4. For demarcation and camouflage lines, we recommend that you use Masking Film.
5. If you wish to use a decal fixing and finishing system, we recommend you use the Microscale System, do not use strong decal solvents such as Solvaset.
6. Once you are happy with the painting of the model, coat it in a clear gloss finish, this can either be over the entire model if the model is finished glossy or spot gloss finish in the areas that have a decal. A good surface finish are clear floor shines such as Johnson wax - Klear. This is sold under different names around the world. Klear can be either brushed on or sprayed.
7. Cut each decal from the sheet as needed. Do not trim the clear varnish finish to close to the decal. Submerge the decal in warm water for about 10 seconds and remove to a flat surface and wait for the decal to release from the backing sheet. A small amount of washing up liquid in the warm water helps the decal release from the sheet.
8. These decals do not require a decal setting solution to lay flat or to conform to the model contours.
9. With a pair of tweezers to hold the backing sheet, slide the decal in position on the model using a small soft brush. Do not use an old painting brush as bits can get under the decal.
10. Carefully remove any excess water with a soft cloth or tissue once you are happy with the position of the decal. Should you make a mistake, dip a brush in the warm water and ease under the edge of the decal. The decal will then easily move to the correct position and again remove the excess water.
11. When the decals are completely dry, gently wipe off all excess decal adhesive.
12. Leave the model to dry completely, spray or paint over the decals with a further coat of Klear or gloss.
13. Should the decal silver for any reason, this is because small air bubbles are under the decal. If found, prick with a pin and apply a small drop of Micro Sol to the decal and allow to dry for up to 12 hours.
14. Finally, coat the model with the required finish, either gloss, semi gloss or matt.
15. Decals are best stored flat and in a cool, dry place and should not be stored in direct sunlight, hot or humid conditions.
16. Should you have any problems with these decals please contact us at the address below.

Mirage F.1M Detailing: Interior Cockpit colour is very Dark Grey (more like a Gunmetal colour) including floors, walls and rear bulkhead. Instrument panels are Gunmetal with Black dials and switch and panels. Martin Baker Mk 10M Ejector seats have Black frames, with Yellow/Black ejector handles below the seat cushion. The head box is Black with Black head cushion. Seat Back cushion are generally Black (Plastic) with covering Mid Green at the top with Khaki seat. Seat belts are Dark Green with some straps Dark Blue. Buckles are metallic Gunmetal. There are various plates on the seats in White/Silver and Red. Undercarriage legs are bright Aluminium. Wheel bay interiors are Aluminium but get very dirty. Wheel hubs are dull silver with Red 'tyre slippage' markings. Air brakes/ speed brakes are Aluminium. Interior of panels seem a mixture of Aluminium and dull Yellow.

Rafale B: Detailing: Interior Cockpit colour is Dark Grey similar to FS36231. Martin Baker Mk 16 Ejector Seats are Black with Yellow/Black ejector handles below the seat cushion. The head box is Black with Black head cushion. Seat Back cushion are generally Black with Mid Green cover at the top and Olive seat cushion. Seat belts are Dark Green with some straps Dark Blue. Buckles are metallic Gunmetal. Undercarriage legs are White. Wheel bay interiors are White but get very dirty.

The Aviation Workshop

13 Charlton Road, Wantage,
Oxon, OX12 8EP, UK

www.theaviationworkshop.co.uk

Email: aviation-workshop@btconnect.com