

DEUTSCH-ACHTUNG: Vor dem Zusammensetzen die Bauanleitung gut durchlesen. Jedes Teil ist nummeriert. Reihenfolge der Montageschritte beachten. Benötigte Werkzeuge: Messer und Feile zum Entfernen und Entgraten der Teile, Gummiband, Klebeband und Wäscheklammern zum Zusammenhalten der geklebten Einzelteile. Plastikteile in einer milden Waschlösung reinigen und an der Luft trocknen, damit der Farbanstrich und die Abziehbilder besser haften. Vor dem Ankleben prüfen, ob die Teile passen; Klebstoff sparsam auftragen. Chrom und Farbe an den Klebeflächen entfernen. Kleine Teile anstreichen, bevor sie vom Rahmen entfernt werden. Farben gut durchtrocknen lassen, erst dann den Zusammenbau fortsetzen. Jedes Abziehbildmotiv einzeln ausschneiden und ca. 20 Sekunden in warmes Wasser tauchen. Das Motiv an der bezeichneten Stelle vom Papier abschleiben und mit Lösspapier andrücken.

ENGLISH-ATTENTION: Carefully read instruction sheet before assembling. Each part is numbered. Consider succession of assembly steps. Required tools: knife and file to remove and trim parts; rubber band, adhesive tape and clothes pegs to hold parts after cementing. Wash plastic in mild detergent solution, rinse and let air dry for better paint and decal adhesion. Scrape chrome and paint at area to be glued: Paint small parts on runner before removing. Allow paint to dry thoroughly before continuing assembly. Cut out each decal one by one and dip it in warm water for approx. 20 secs.; slide decal from the paper at the marked position and dab with blotting-paper.

FRANCAIS: ATTENTION: lire soigneusement la fiche d'instructions avant d'assembler. Chaque pièce est numérotée. Suivre la succession des étapes de montage. Outils nécessaires: couteau et lime pour détacher et ébarber les pièces, élastiques, papier adhésif et pinces à linge pour maintenir ensemble les pièces après collage. Laver le plastique dans une solution détergente légère, rincer et laisser sécher à l'air libre pour une meilleure adhérence de la peinture et des décalés. Ajuster les pièces ensemble avant de coller. Employer la colle Revell pour plastique exclusivement. Utiliser très peu de colle à chaque fois. Gratter le chrome ou la peinture sur les surfaces à coller. Peindre les petites pièces sur le support avant de les détacher. Laisser la peinture sécher totalement avant de continuer l'assemblage. Découper chaque décalé séparément et le plonger dans l'eau chaude environ 20 secondes. Faire glisser le décalé du papier à l'endroit du décor et tamponner avec du papier buvard.

NEDERLANDS: OPGELET: alvorens te beginnen met het in elkaar zetten, eerst de handleiding goed doorlezen. Elk onderdeel is genummerd. Aandacht besteden aan de volgorde van montage. Het benodigde gereedschap: mesje en vijl voor het verwijderen en het afbramen van de onderdelen, elastiek, plakband en wasknijpers gebruiken voor het bij elkaar houden van de gelijmde onderdelen. De plastic onderdelen met een zacht wasmiddel schoonmaken en laten drogen zodat de verf en de transfers beter hechten. Alvorens te lijmen, eerst vaststellen of de onderdelen

passen; de lijm zuinig opbrengen. Chrom en verf van de op elkaar te lijmen delen verwijderen. Kleine onderdelen verven voor deze van het gietraam verwijderd worden. De verf goed laten drogen en eerst dan verder gaan met de bouw. Elk transfer apart uitknippen en ca. 20 seconden in lauw/warm water leggen. Het transfer op de juiste plaats van het papier schuiven op het model en met vloeipapier aandrukken.

SVENSKA: VIKTIGT: Läs noggrant igenom instruktionerna innan du börjar bygga. Varje del är numrerad. Tänk igenom ordningsföljden för de olika momenten. Följande verktyg krävs: kniv och fil för att ta loss och putsa detaljerna, gummiband, tejp och klädnyppor för att hålla detaljerna på plats medan limmet torkar. Tvätta alla plastdetaljerna i mild tvålösning, skölj och låt lufttorka för att få färg och dekalere att fästa bättre. Provpassa alltid detaljerna innan du limmar. Använd endast Revells plastlim. Använd sparsamt med lim. Skrapa bort krom och färg från den yta som ska limmas: måla smådetaljerna innan du skär loss dem. Låt all färg torka ordentligt innan du fortsätter byggandet. Skär ut varje dekal för sig och blöt den i ljummet vatten i ungefär 20 sekunder, och låt dekalerna glida av papperet och ner på det markerade läget: sug sedan försiktigt upp det mesta vattnet med läskpapper eller en tygtrasa.

ITALIANO: Attenzione: Leggere attentamente le istruzioni prima dell'assemblaggio. Ogni pezzo è numerato. Tener presente la successione delle fasi di assemblaggio. Attrezzi necessari: coltello e lima per rimuovere e rifinire le parti elastiche nastro adesivo e spilli per tenere le parti dopo averle incollate. Lavare la plastica con un detergente delicato, sciacquare e lasciare asciugare all'aria per una migliore adesione della vernice e delle 'decal'. Accoppiare le parti da incollare. Usare solamente 'Revell plastic cement'. Usare poco collante. Grattare la cromatura e la vernice nei punti da incollare. Dipingere i piccoli accessori sul supporto prima di rimuoverli. Far seccare bene la vernice prima di continuare nell'assemblaggio. Ritagliare una per una le 'decal' ed immergerle in acqua tiepida per circa 20 secondi. Applicare ogni 'decal' nella posizione segnata e tamponare con della carta assorbente.

ESPAÑOL: ATENCION: cuidadosamente lean la hoja de instrucciones antes del montaje. Cada pieza es numerada, consideren la sucesion de las operaciones de montaje. Herramientas requeridas: cuchilla y lima para quitar y desbarbar las piezas, banda de caucho, cinta adhesiva y pinzas para sujetar las piezas, despues de engomarias. Lavar el plastico en solucion detergente suave, aclarar y dejar que se seque al aire para una mejor adhesion de la pintura y la calcomania. Adaptar las piezas bien juntas antes de encolar. Solamente utilizar pegamento plastico Revell. Utilizar el pegamento cautelosamente y sin exceso. Raspar el cromado y la pintura en la zona que ha de ser encolada: Pintar las piezas pequeñas giratorias antes de sacarlas. Dejar que la pintura seque totalmente antes de continuar el montaje. Cortar cada calcomania una por una y sumergirla en agua caliente durante aproximadamente 20 segundos. Deslizar la calcomania del papel en la posición marcada y golpearla suavemente con el papel secante.

Form hergestellt und im Eigentum von Revell Inc. Widerrechtliche Nachahmungen werden gerichtlich verfolgt.

Mould produced by and the property of Revell Inc. Unlawful imitations will be subject to prosecution.

Forme produite par et propriété de Revell Inc. Les contrefaçons seront poursuivies par voies légales.

Vorm vervaardigd door en eigendom van Revell Inc. Onrechtmatige nabootsingen worden gerechtelijk vervolgd.



Kleben
Glue
A coller
Lijmen
Limmas
Incollare
Engomar



Nicht kleben.
Don't glue.
A ne pas coller.
Niet lijmen.
Niet limmen.
Timmas ej.
Non incollare.
No engomar.



Anzahl der Arbeitsgänge.
Number of working steps.
Nombre d'étapes de travail
Het aantal der bouwhandelingen.
Antal arbetsmoment.
Numero di passaggi.
Numero de operaciones de trabajo.



Wahlweise
Optional
Facultatif
Ter keuze
Valfritt
Facoltativo
Opcional

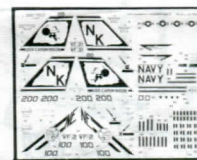

Abziehbild in Wasser einweichen und anbringen.
Soak and apply decals.
Mouiller et appliquer les décalés.
Transfer in water even laten weken en opbrengen.
Blöt and fäst dekalerna.
Immergere in acqua ed applicare decal.
Remojar y aplicar las calcomanias.



Abbildung zusammengebauter Teile.
Shown assembled.
Vu assemblé.
Afbeelding van een gebouw onderdeel.
Visas hopsatt.
Figura assemblata.
Presentado montado.



Klarsichtteile
Clear parts
Pièces transparentes
Transparente onderdelen
Gennomskinliga detaljer
Parte trasparente
Limpiar las piezas



Remove and throw away
Enfernen (Abfall)
Ouite y tire
Verwijderen en weggooien
A retirer et jeter
Avlagsnas och makuleras
Rimouvi ed elimina

<p>60% A 40%</p> <p>GREY GRAU 374 + DARK GREY DUNKELGRAU 378</p> <p>GRIS GRIS FONCE GRIJS DONKERGRIJS GRÁ MORKANGRÁ GRIGIO GRIGIO SCURO</p>	<p>B</p> <p>GREY GRAU 374</p> <p>GRIS GRIJS GRÁ GRIGIO</p>	<p>20% C 80%</p> <p>LIGHT GREY HELLGRAU 371 +</p> <p>GRIS CLAIR VAALGRIJS LJUSGRÁ GRIGIO CHIARO</p>	<p>D</p> <p>WHITE WEISS 301</p> <p>BLANC WIT VIT BIANCO</p>	<p>E</p> <p>KHAKI BROWN KHAKIBRAUN 86</p> <p>BRUN KAKI KHAKIBRUIN KHAKIBRUN KAKI</p>	<p>F</p> <p>BLACK SCHWARZ 302</p> <p>NOIR ZWART SVART NERO</p>	<p>G</p> <p>ANTHRACITE ANTHRAZIT 9</p> <p>ANTHRACIET ANTHRACIET ANTRACIT ANTRACITE</p>		
<p>H</p> <p>BROWN BRAUN 381</p> <p>BRUN BRUIN BRUN MARRONE</p>	<p>I</p> <p>ALUMINIUM ALUMINIUM 99</p> <p>ALUMINIUM ALUMINIUM ALUMINIUM ALUMINIUM</p>	<p>J</p> <p>FIERY RED FEUERROT 330</p> <p>ROUGE VERMILLON VUURROOD ELDRÖD ROSSO ACCESO</p>	<p>K</p> <p>LEAF GREEN LAUBGRÜN 364</p> <p>VERT FEUILLE LOOF GROEN LÖVGRÖN VERDE-FOGLIA</p>	<p>L</p> <p>METALLIC GREY EISENFARBIG 91</p> <p>GRIS METALLIQUE IJZERKLEUR JÄRNGRÅ FERRO</p>	<p>M</p> <p>GREY GRAU 57</p> <p>GRIS GRIJS GRÁ GRIGIO</p>	<p>N</p> <p>LUFTHANSA YELLOW LUFTHANSA GELB 310</p> <p>JAUNE LUFTHANSA LUFTHANSA GEEL LUFTHANSA GUL GIALLO-LUFTHANSA</p>	<p>O</p> <p>MATT YELLOW MATT GELB 15</p> <p>JAUNE MAT MAT GEEL MATT GUL GIALLO SMORTO</p>	<p>P</p> <p>MATT LIGHT GREY MATT HELLGRAU 75</p> <p>GRIS CLAIR MAT MAT LICHTGRUIS MATT LJUSGRÁ GRIGIO CHIARO SMORTO</p>

Dieser Bausatz wurde in mehrfachen Qualitäts- und Gewichtskontrollen auf Vollständigkeit überprüft. Reklamationen können nur bearbeitet werden, wenn die Bauanleitung und das aus der Kartonage ausgeschnittene EAN-Strichcode-Feld eingeschickt werden. Einzelteile aus unseren Bausätzen für Umbauten usw. liefern wir mit Rechnung per Nachnahme. Unsere Adresse: Revell AG, Abteilung X, Henschelstr. 20-30, 32257 Bünde.

This model kit underwent various quality and weight controls to assure its completeness. Queries can only be processed when the building instructions are sent to Revell together with the EAN-Code of the product which is to be cut out from the packaging. Individual components of our model kits for conversion purposes can be ordered C.O.D. Write to: Revell AG, Department X, Henschelstr. 20-30, D-32257 Bünde.

L'intégralité des pièces de ce modèle réduit a été vérifiée au cours de plusieurs contrôles de qualité et de poids. Des réclamations ne peuvent être prises en considération que si le guide de montage ainsi que le code à barres EAN découpé du cartonnage nous soient envoyés. Des pièces détachées de nos modèles réduits pour transformations, etc. sont livrées suivant facture contre remboursement. Notre adresse: Revell AG, département X, Henschelstr. 20-30, D-32257 Bünde.

Deze bouwdoos is bij meerdere kwaliteits- en gewichtskontroles op volledigheid gecontroleerd. Klachten kunnen alleen dan in behandeling worden genomen, wanneer de bouwvoorwaarden en het uit de kartonnen doos uitgeknipte veld met de EAN barcode worden opgestuurd. Losse onderdelen uit onze bouwdozen voor ombouw en dergelijke leveren wij met factuur onder rembours. Ons adres: Revell AG, Afdeling X, Henschelstr. 20-30, D-32257 Bünde.

1

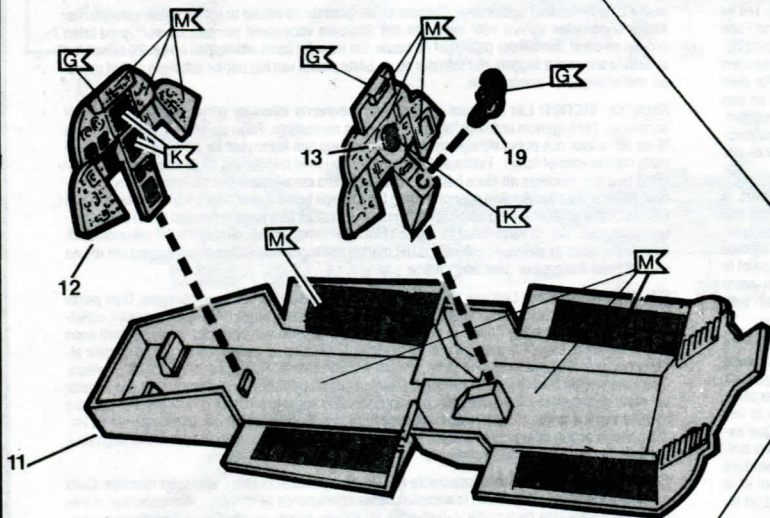

2

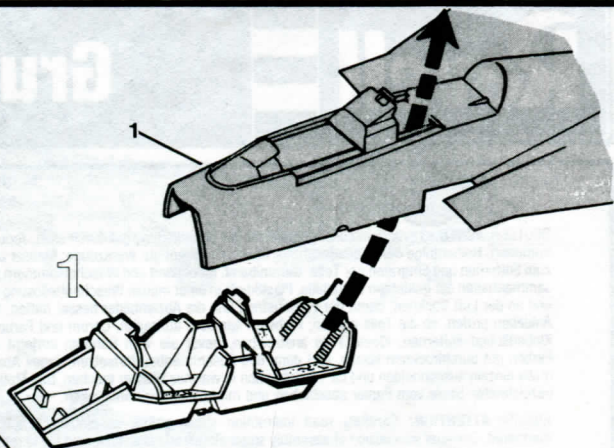

3

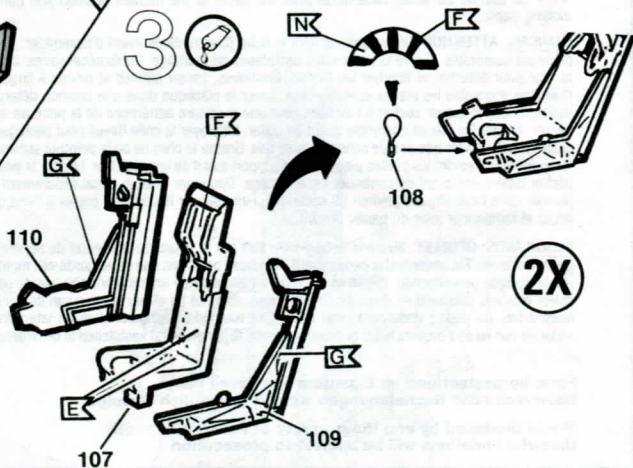

4

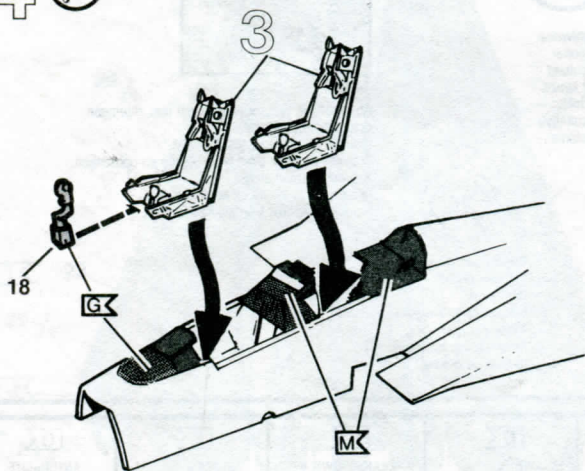

5

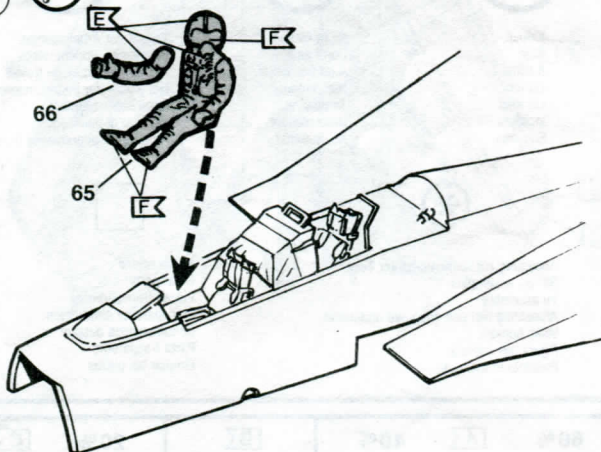

6

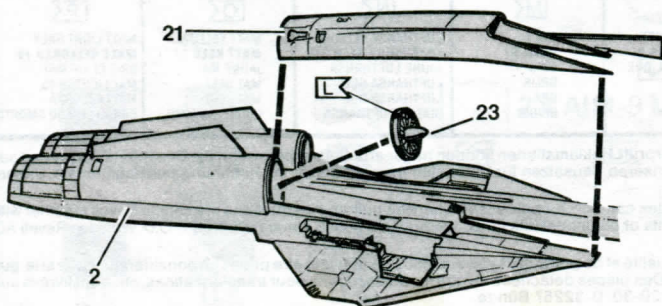

7

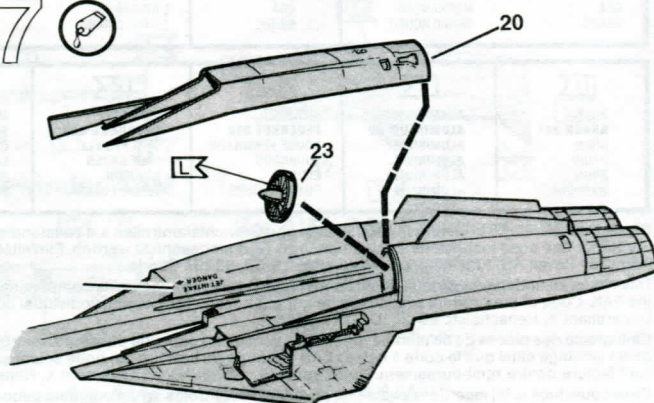

8 

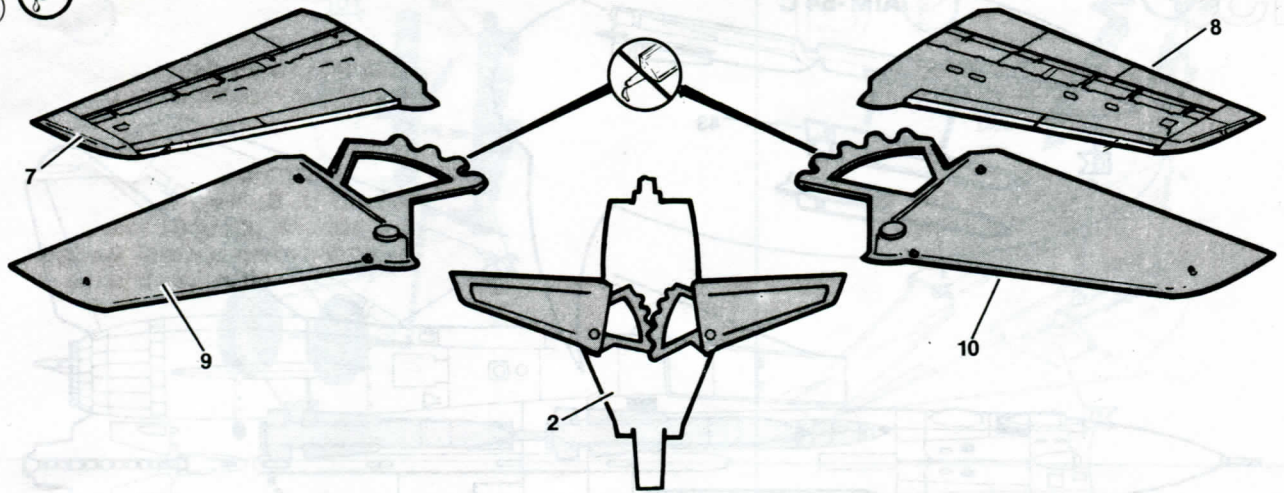

9 

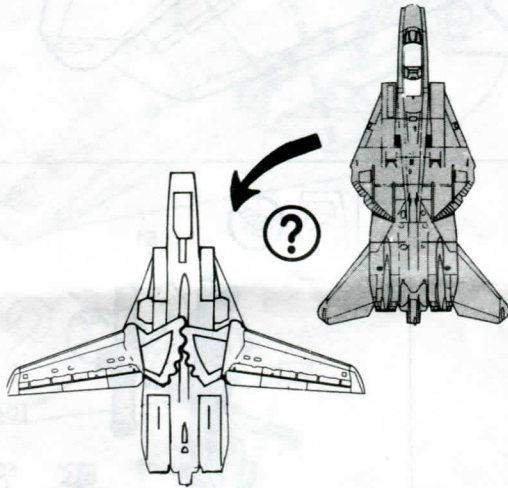

10 

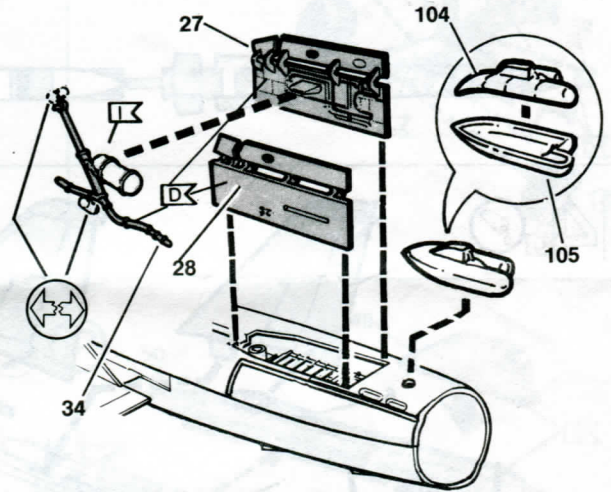

11 

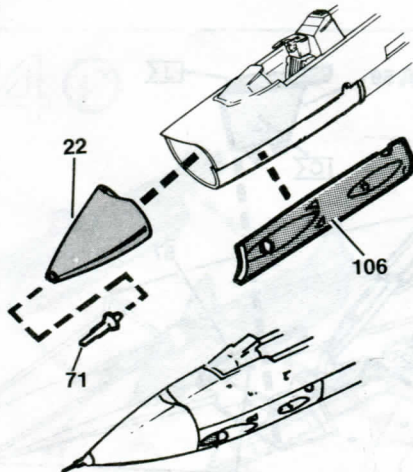

12 

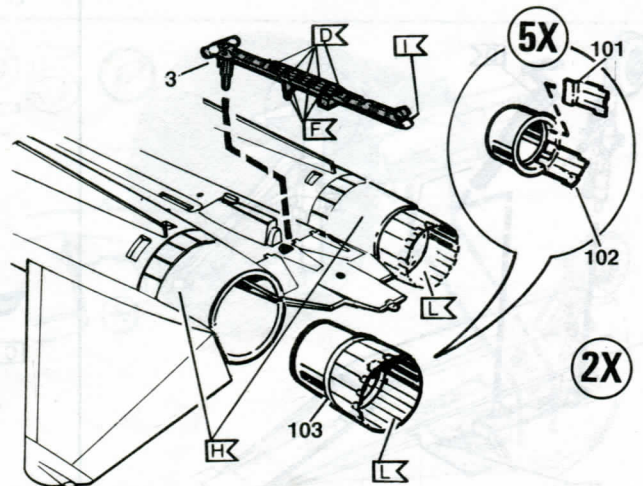

13

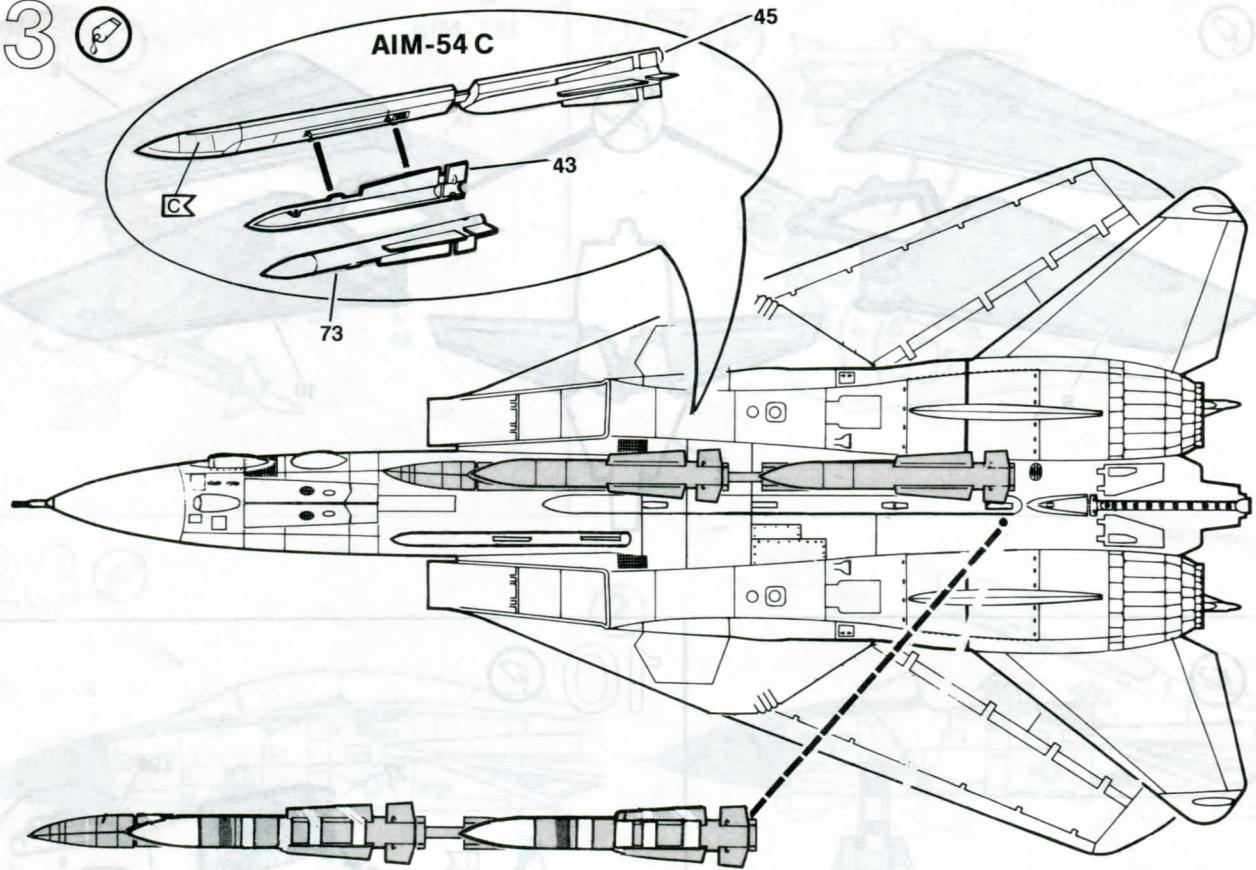

14

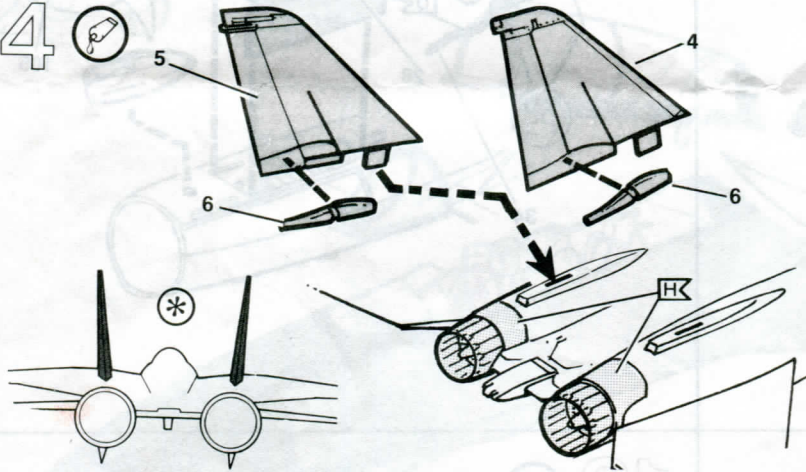

15

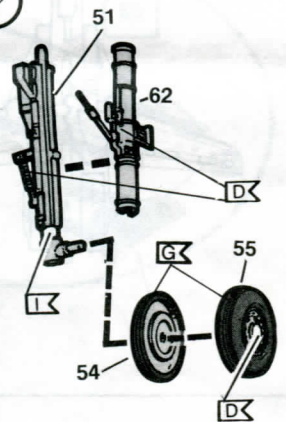

16

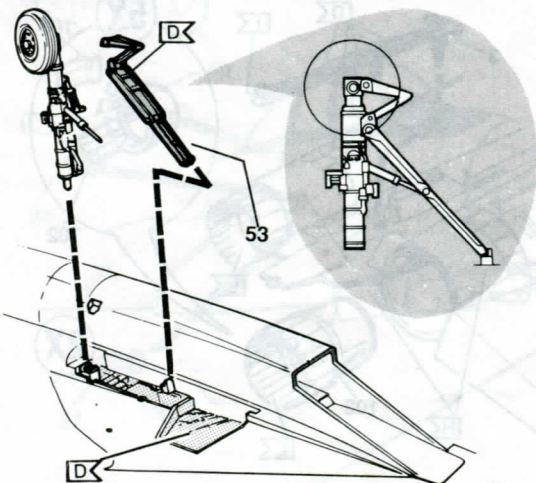

17

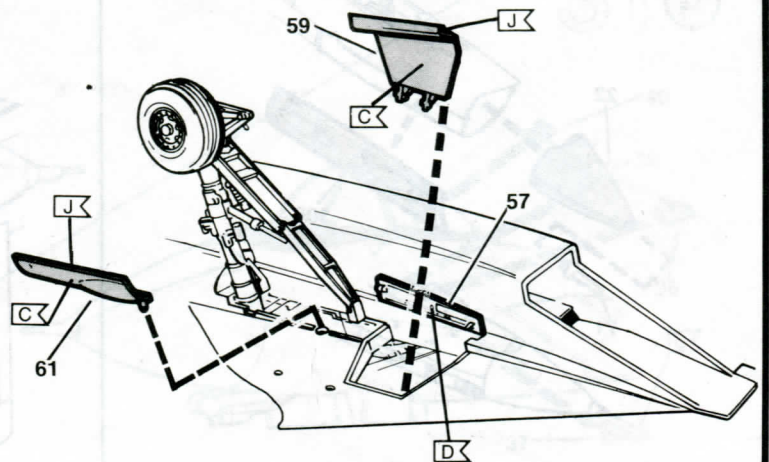

18

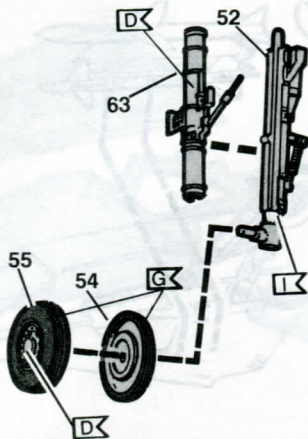

19

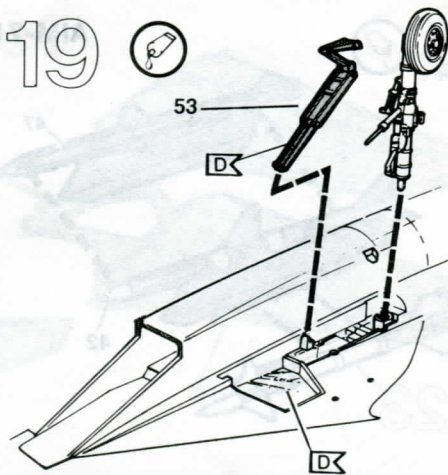

20

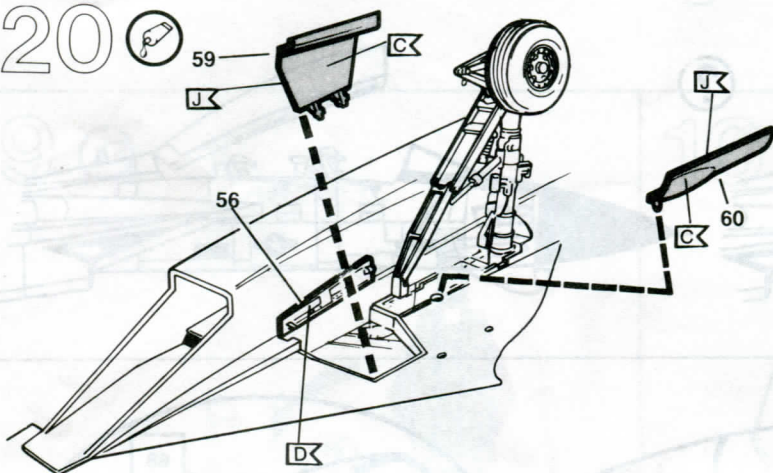

21

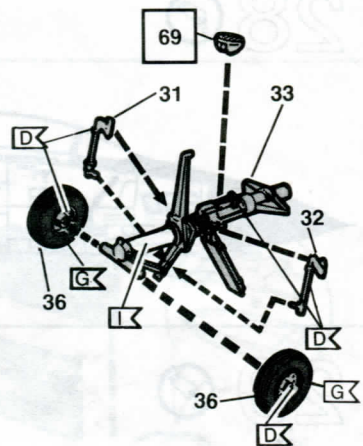

22

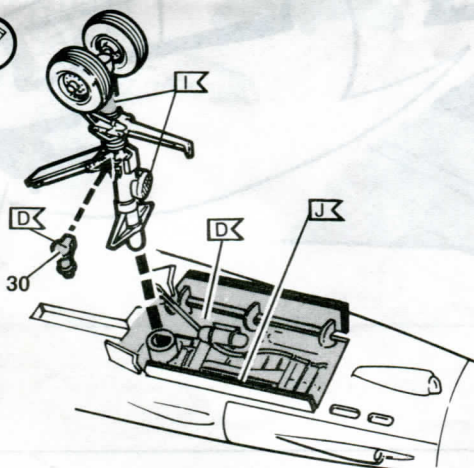

23

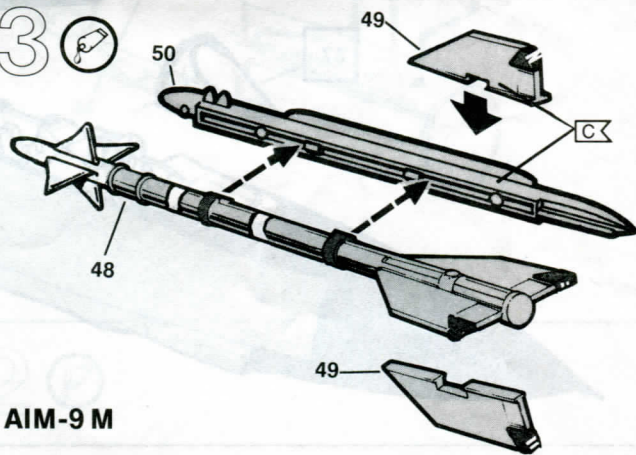

AIM-9 M

24

AIM-7 M

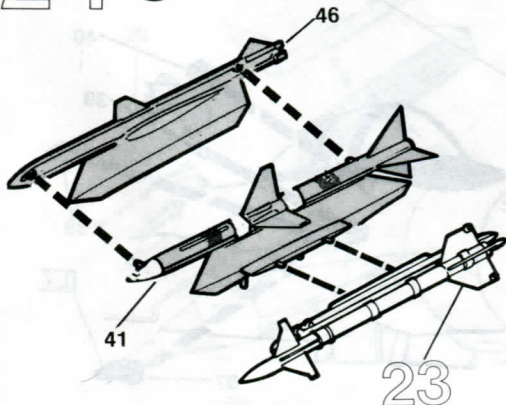

25

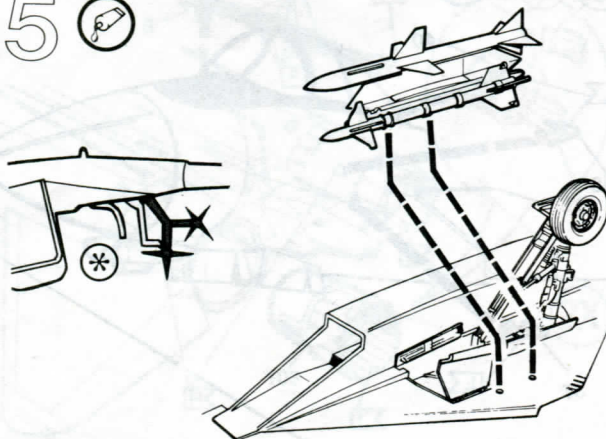

26



AIM-7 M

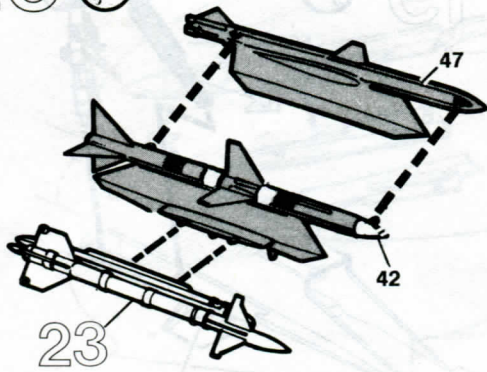

27

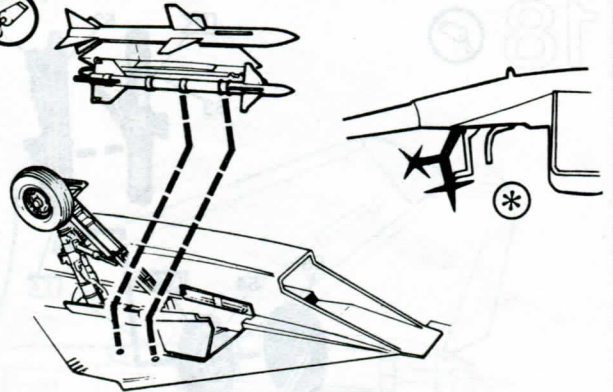

28

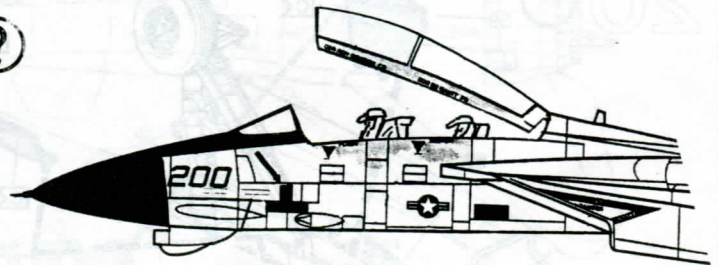
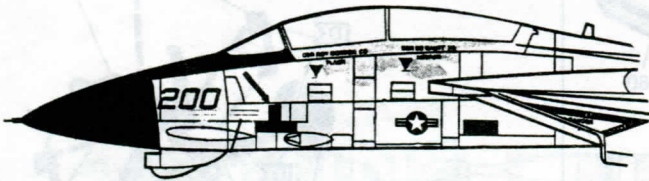

29

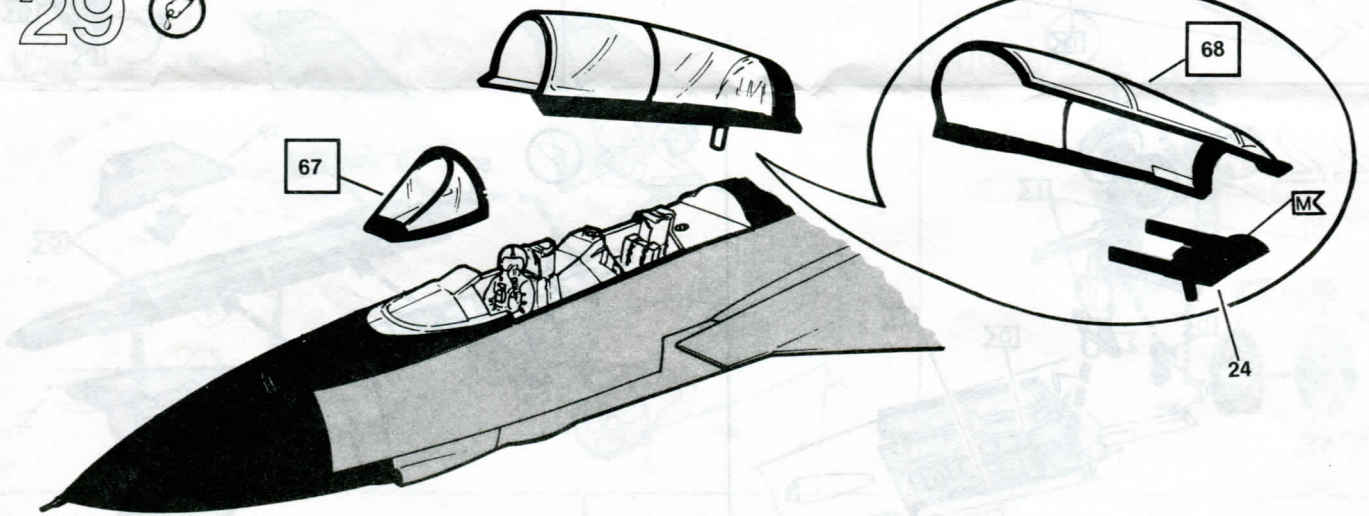

30

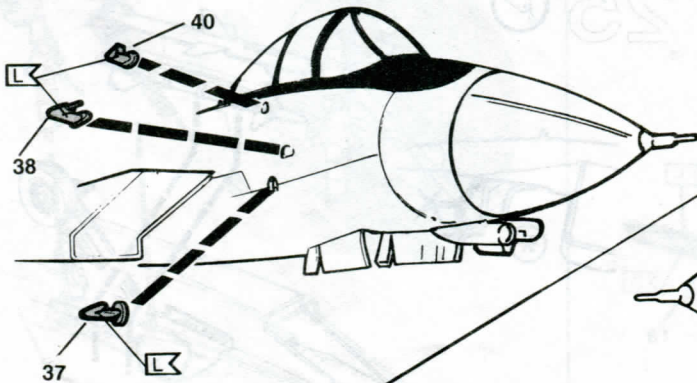

31

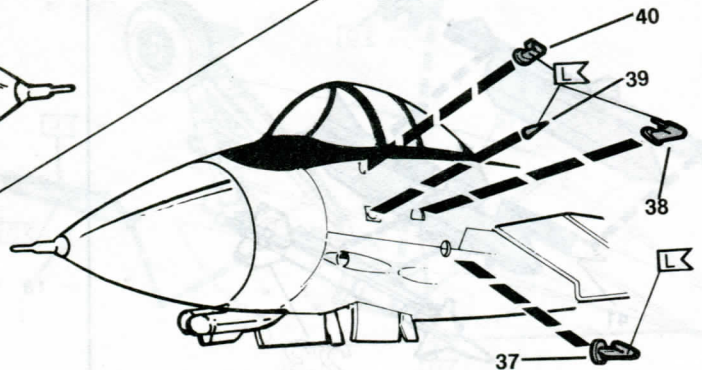

32 ?

Grumman F-14 D Tomcat VF-31 Version

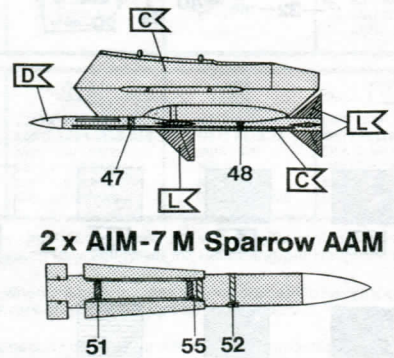
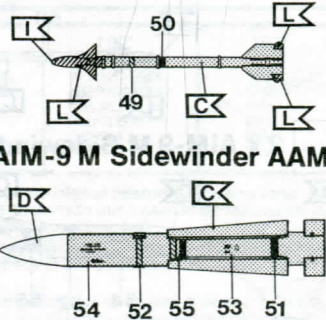
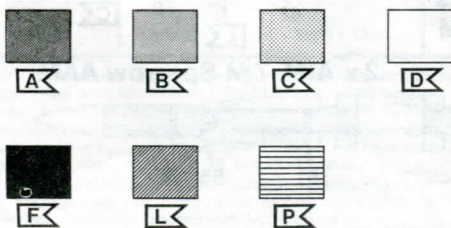
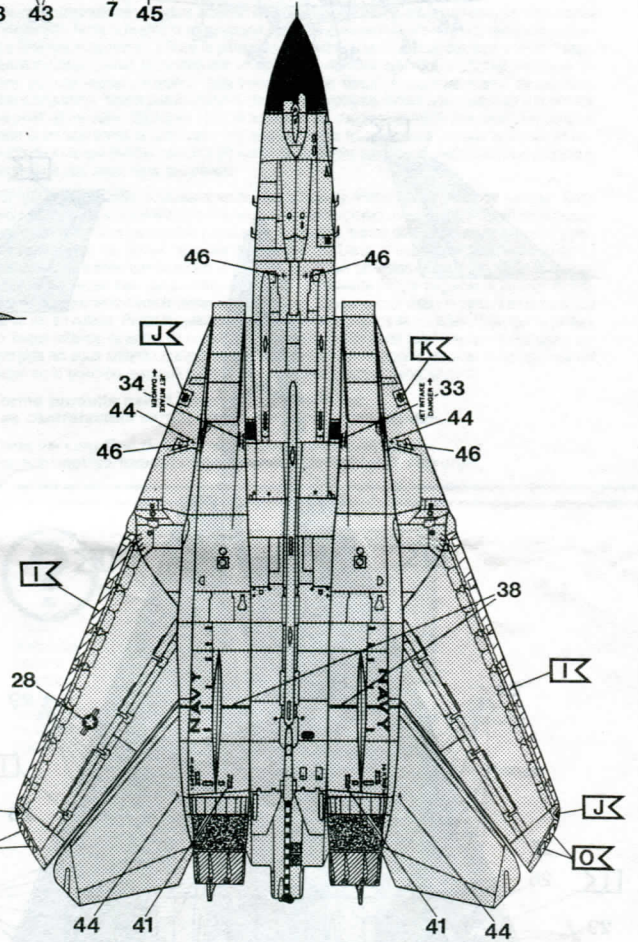
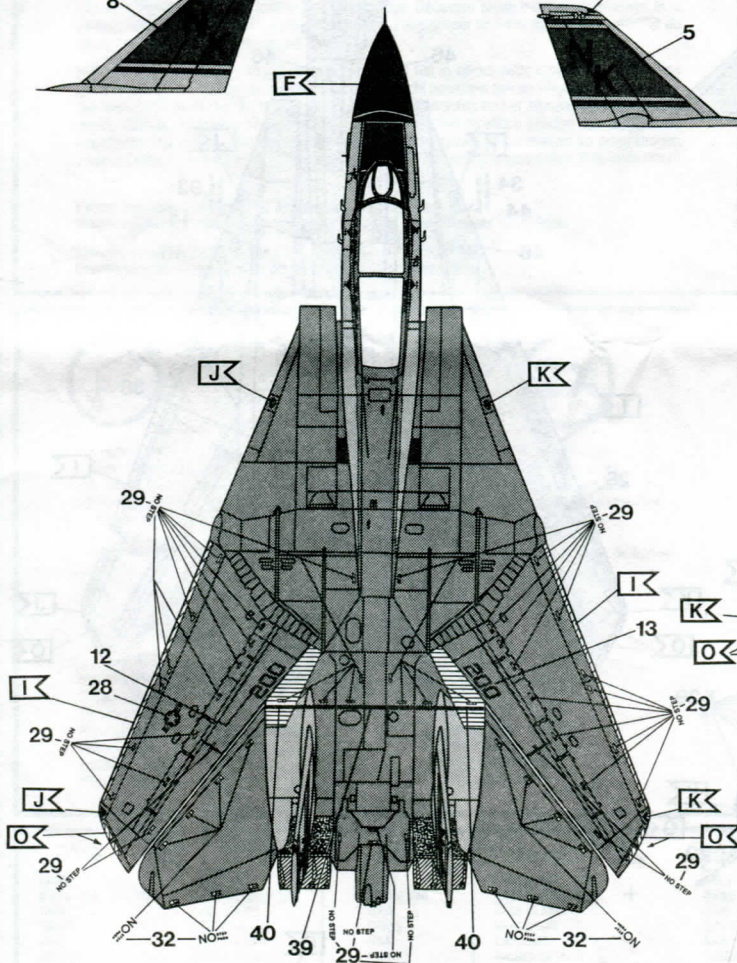
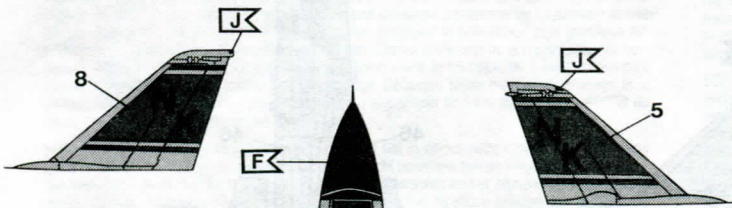
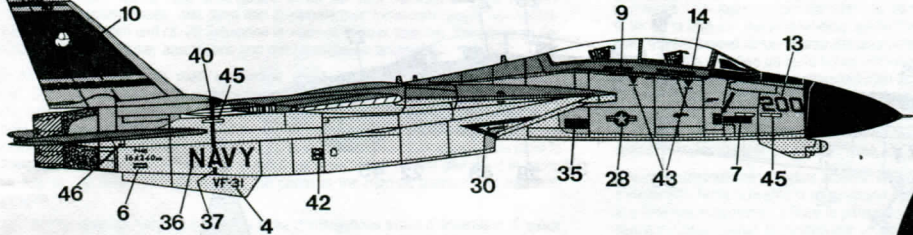
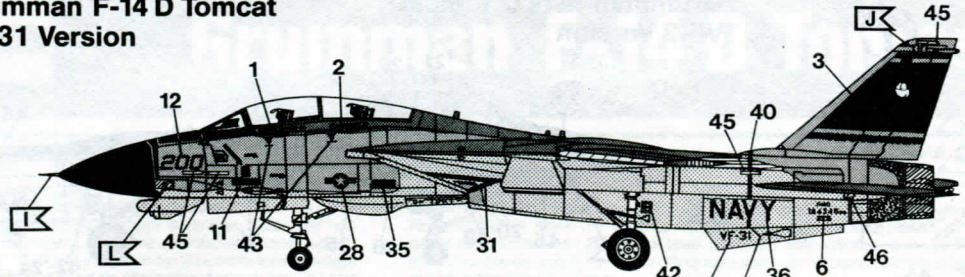
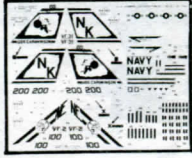

2 x AIM-9 M Sidewinder AAM

2 x AIM-7 M Sparrow AAM

4 x AIM-54 C Phoenix AAM

33 ?

Grumman F-14 D Tomcat
VF-2 Version

