

**ENGLISH:** ASSEMBLY DRAWINGS SHOULD BE REVIEWED BEFORE PROCEEDING WITH CONSTRUCTION. A NUMBER IDENTIFIES EACH PLASTIC PART FOR YOUR CONVENIENCE. PAINT SMALL PARTS ON RUNNER BEFORE REMOVING. ALLOW PAINT TO DRY THOROUGHLY BEFORE CONTINUING ASSEMBLY OF KIT. SCRAPE CHROME OR PAINT AT AREA TO BE GLUED. WASH PLASTIC IN MILD DETERGENT SOLUTION. RINSE AND LET AIR DRY FOR BETTER PAINT AND DECAL ADHESION.

**DEUTSCH:** VOR DEM ZUSAMMENBAU DIE BAUANLEITUNG GUT DURCHLESEN. JEDES TEIL IST NUMERIERT. KLEINE TEILE ANSTREICHEN BEVOR SIE VOM RAHMEN ENTFERNT WERDEN. FARBEN GUT TROCKNEN. ERST DANN DEN ZUSAMMENBAU FORTSETZEN. CHROM UND FARBE AN DEN KLEBEFLÄCHEN ENTFERNEN. PLASTIKTEILE IN EINER MILDEN WASCHMITTELLÖSUNG REINIGEN UND AN DER LUFT TROCKNEN, DAMIT FARBE U. ABZIEHBILDER BESSER HAFTEN.

**FRANCAIS:** EXAMINER LES SCHEMAS D'ASSEMBLAGE AVANT DE COMMENCER LA CONSTRUCTION. UN NUMERO IDENTIFIE CHAQUE PIECE DE PLASTIQUE POUR PLUS DE FACILITE. PEINDRE LES PETITES PEICES SUR LE SUPPORT AVANT DE LES ENLEVER. LAISSER LA PEINTURE SECHER COMPLETEMENT AVANT DE CONTINUER L'ASSEMBLAGE DU KIT. GRATTER LE CHROME OU LA PEINTURE SUR LES SURFACE A COLLER. LAYER LE PLASTIQUE DANS UNE SOLUTION DE DETERGENT LEGERE, RINCER ET LAISSER SECHER A L'AIR POUR UNE MEILLEURE ADHERENCE DE LA PEINTURE ET DES DECALS.

**NEDERLANDS:** BESTUDER DE MONTAGE TEKENINGEN. VOORDAT U MET BOUWEN BEGINT. VOOR UW GEMAK, IDENTIFICEERT EEN NUMMER ELK PLASTIC DEEL. VERF KLEINE DEELTJES OP KIBOOM VOORDAT U ZE VERWYDERD. LAAT VERF GRONDIG DROGEN VOORDAT U DE MONTAGE VAN HET MODEL VOORTZET. SCHRAP CHROOM OF VERF VAN HET GEDEELTE DAT GELYMD WORDT. WAS PLASTIC MET EEN ZACHT ZEEP, SPOEL AF, EN LAAT IN LUCHT DROGEN, ZODAT VERF EN DECAL BETER PLAKKEN.

**SVENSKA:** IHOPSÄTTNINGSSKISSEN BÖR GRANSKAS INNAN IGÅNGSÄTTANDE AV BYGGANDET. ETT NUMMER IDENTIFIKERAS VARJE PLASTDEL FÖR DIN EGEN BEKVÄMLIGH ET. MALA DE SMA BITARNA DIREKT PÅ FARAN INNAN DE TAS BORT. LÅT FARGEN TORKA GRUNDLIGT INNAN FORTSÄTT BYGGANDE. SKRAPA AV KROMEN ELLER MALA PÅ DELARNA SOM SKALL KLISTRAS. TVÄTTA PLASTEN I MILD TVÄTTMEDELÖSNING, SKOJ OCH LUFTTORKA FÖR BÄTTR FÄSTANDE AV FARG OCH DEKALER.

**ESPAÑOL:** DIBUJOS DE ENSAMBLAJE DEBEN SER REPASADOS ANTES DE SEGUIR CON LA CONSTRUCCION. UN NUMERO IDENTIFICA CADA PARTE DEL PLASTICO PARA SU CONVENIENCIA. PINTE PARTES PEQUENAS DEL KIT ANTES DE QUITARLAS. DEJE SECAR BIEN LA PINTURA ANTES DE SEGUIR EL ENSAMBLAJE. RASPE EL CROMO O LA PINTURA DEL SITIO ANTES DE SER PEGADO. LAVE EL PLASTICO EN UNA SOLUCION SUAVE DETERGENTE, ENJUAGUE, Y DEJE SECAR EN EL AIRE PARA MEJOR ADHESION DE LA PINTURA Y CALCOMANIA.

**ITALIANO:** I DISEGNI DELL'ASSEMBLAGGIO DOVREBBERO ESSERE RICONTROLLATI PRIMA DI INIZIARE IL MONTAGGIO. OGNI PEZZO E IDENTIFICATO DA UN NUMERO PER VOSTRA MAGGIORE COMODITA. VERNICIARE LE PARTI PICCOLE SULLA GUIDA DE SCORRIMENTO PRIMA DE TOGLIERLE. LASCIAR ASCIUGARE LA VERNICE PRIMA DI CONTINUARE IL MONTAGGIO. RASCHIAR LA PITTURA O IL CROMO DALLE PARTI CHE DEVONO ESSERE INCOLLATE. LAVARE I PEZZI DI PLASTICA CON UN DETERGENTE NON TROPPO FORTE, SCIACQUARE E LASCIAR ASCIUGARE AFFINCHÉ VERNICE E DECALCOMANIE ADERISCANO MEGLIO.



GLUE  
KLEBEN  
COLLE  
LIJM  
KLISTER  
PEGA  
COLLA



NO GLUE REQUIRED  
NICHT KLEBEN  
LA COLLE N'EST PAS NECESSAIRE  
GEEN LIJM NODIG  
INGET KLISTER BEHOVTS  
NO NECESITA PEGA  
NON C'E BISOGNO DI COLLA



DO IT THIS MANY TIMES  
ANZAHL DER ARBEITSGÄNGE  
LE FAIRE CE NOMBRE DE FOIS  
DOE HET ZOVEEL KEER  
GJOR DET SA MANGA GANGER  
FATELO TUTTE QUESTA VOLTE  
HAGALO ESTA CANTIDAD DE VECES



OPTIONAL  
WAHLWEISE  
FACULTATIF  
NAAR KEUZE  
VALFRI  
FACOLTATIVO  
OPCIONAL

18

CLEAR  
KLARSICHTTEILE  
TRANSPARENT  
DOORZICHTIG  
KLART  
VIA LEBERA  
TRANSPARENTE

20

LIGHT GREY  
HELLGRAU  
GRIS CLAIR  
VAALGRIS  
LIUSGRA  
GRIGIO CHIARO

SHOWN ASSEMBLED  
ABBILDUNG ZUSAMMENGEBAUTER TEILE



VU ASSEMBLE  
GEMONTEERD GETOOND  
VISAD IHOPSÄTTNING  
MOSTRADO ARMADO  
ILLUSTRAZIONE DEL PEZZO MONTATO



SOAK AND APPLY DECAL  
ABZIEHBILD IN WASSER EINWEICHEN UND ANBRINGEN  
MOUILLER ET APPLIQUER DECAL COMANIE  
MAAK PLAKPLAATJE DOOR EN DOOR NAT EN BEVESTIG HET  
FUKTA KLISTERMÄRKENA I VATTEN OCH SÄTT FAST  
REMOJE Y PEGUE LA CALCOMANIA  
IMMERGERE NELL'ACQUA APPLICARE CALCOMANIA

Sollte es einmal vorkommen, daß ein Teil im Bausatz fehlt, bitte an REVELL AG, Postfach 2609 + 2620, Abteilung X, 4980 Bünde, schreiben und die Bauanleitung, auf der das fehlende Teil angekreuzt ist, mitschicken, sonst können wir keinen Ersatz leisten.

Should you find any missing parts, please write to REVELL AG, 2609 + 2620, department X, D-4980 Bünde, W. Germany, and we will send you these as quickly as possible with our compliments. Please indicate clearly with a cross on the instruction leaflet, which piece(s) are missing. Always remember to write your name and address clearly and in full.

Zou het voorkomen, dat er een deel in de bouwdoos ontbreekt, kunt U schrijven naar REVELL AG, Postbus 2609 + 2620, Afdeling X, D-4980 Bünde. De bouwbeschrijving waarop het ontbrekende deel aangekruist is, bijsluiten, anders kunnen wij U dit onderdeel niet vergoeden. Vergeet vooral niet Uw naam en adres duidelijk te vermelden.

Pour toute pièce manquante, écrivez à REVELL AG, Postbus 2609 + 2620, département X, D-4980 Bünde, et cet élément vous sera aussitôt envoyé et ce, gratuitement. Il vous suffit dans ce cas de marquer d'une croix la pièce manquante sur la feuille d'instruction du modèle choisi. N'oubliez surtout pas d'écrire clairement votre nom et adresse.

23 38 39 40 41  
50 114 115 118

PARTS NOT USED  
NICHT BENODIGTE BAUTEILE  
PIECES NON UTILISEES  
DEELEN NIET GEBRUIKT  
DELAR INTE ANVANDA  
PARTI NON USATE

<b>A</b>	<b>B</b>	<b>C</b>	<b>D</b>	<b>E</b>	<b>F</b>	<b>G</b>	<b>H</b>	<b>I</b>	<b>K</b>	
METALLIC GREY EISENFARBIG 91 GRIS METALLIQUE IJZERKLEUR JÄRNGRÅ FERRO	MATT BLACK MATT SCHWARZ 8 NOIR MAT MATT ZWART NERO SMORTO	WHITE WEISS 301 BLANC WIT BIANCO	LUFTHANSA YELLOW LUFTHANSA GELB 310 JAUNE LUFTHANSA LUFTHANSA GEEL LUFTHANSA GUL GIALLO-LUFTHANSA	SILVER SILBER 90 ARGENT ZILVER SIVER ARGENTO	MATT WHITE MATT WEISS 5 BLANC MAT MATT WIT BIANCO SMORTO	IC BEIGE IC BEIGE 314 IC BEIGE IC BEIGE IC BEIGE	GOLD GOLD 94 COULEUR OR GOLD GULD ORO	LIGHT GREY HELLGRAU 371 GRIS CLAIR VAALGRAUJ LJUSGRÅ GRIGIO CHIARO	RED ROT 330 ROUGE ROOD ROD ROSSO	
70%	<b>J</b>	30%	<b>L</b>	<b>M</b>	<b>N</b>	<b>O</b>	<b>P</b>	80%	<b>R</b>	20%
IC GREENISH BLUE IC GRÜNBLAU 351 BLEU NAVY IC GROENBLAUW GRÖNBLÅ BLEU NOTTE	WHITE WEISS 301 BLANC WIT BIANCO	LEAF GREEN LAUBGRÜN 364 VERT FEUILLE LOOF GROEN LOVGRÖN VERDE-FOGLIA	MATT BRICK RED MATT ZIEGELROT 37 ROUGE FONCE MAT MATT DONKER ROOD MATT MORK RÖD ROSSO SCURO SMORTO	ALUMINIUM ALUMINIUM 99 ALUMINIUM ALUMINIUM ALUMINIUM	MATT MOUSE GREY MATT MAUSGRAU 47 GRIS SOURIS MAT MATT MUISGRJUS MATT MUSGRÅ GRIGIO TOPO SMORTO		COPPER KUPFER 93 CUIVRE KOPER COPPER RAME	GREY GRAU 374 GRIS GRJUS GRÅ GRIGIO	WHITE WEISS 301 BLANC WIT BIANCO	

**O**

GREY  
GRAU 374  
GRIS  
GRJUS  
GRÅ  
GRIGIO

1

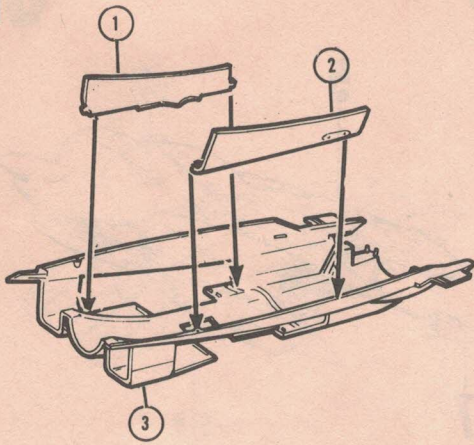

2

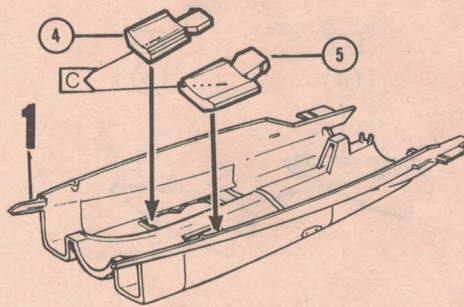

3

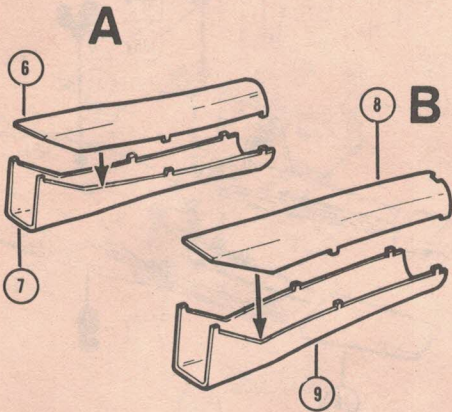

4

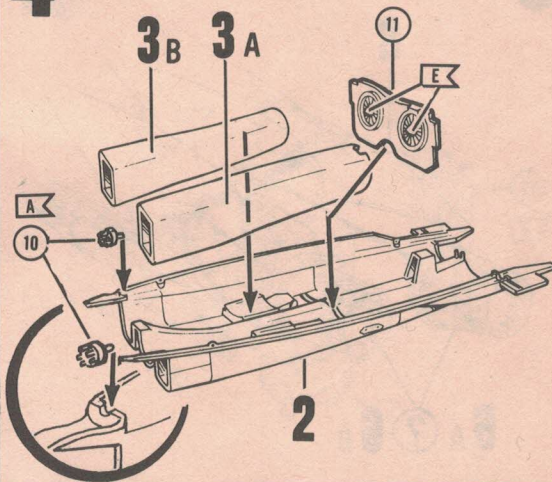

5

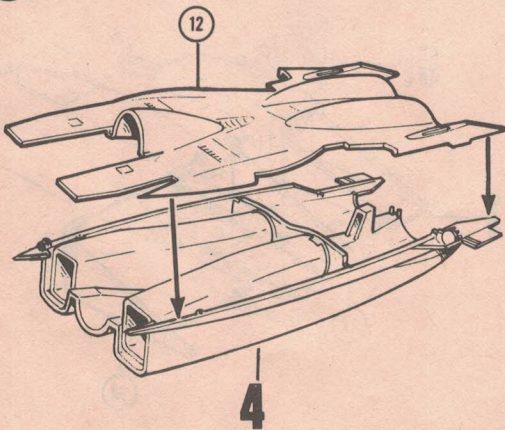

6

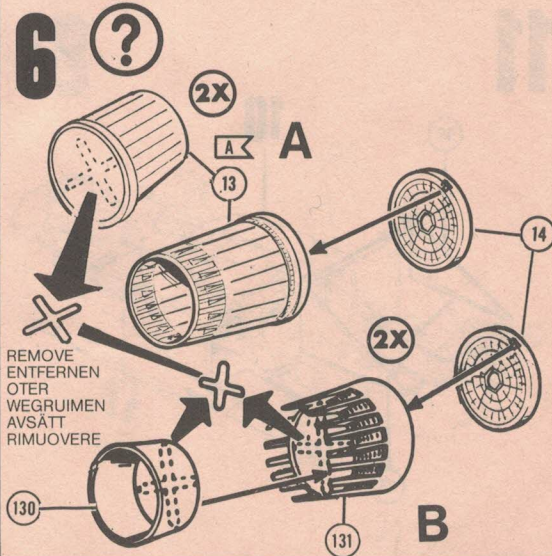

7

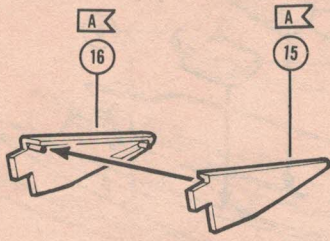

8

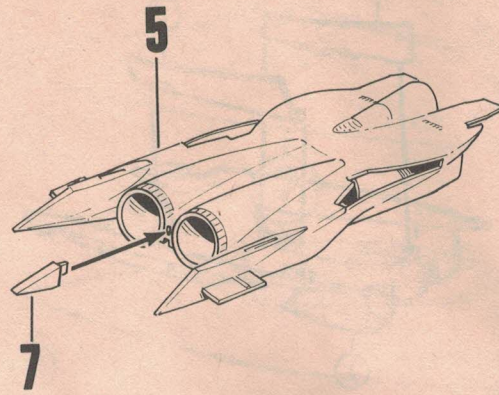

9

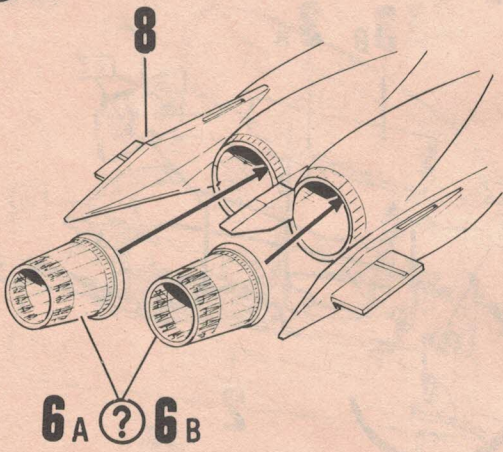

10

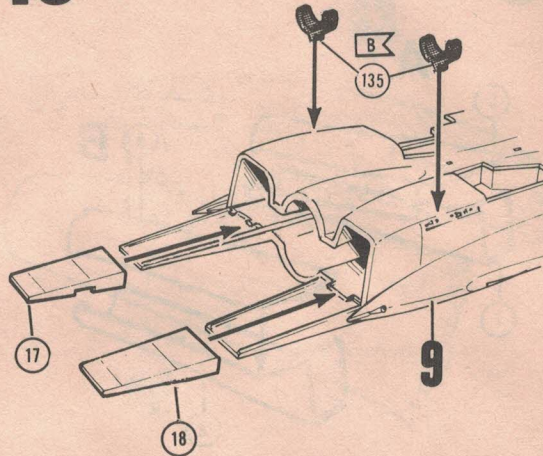

11

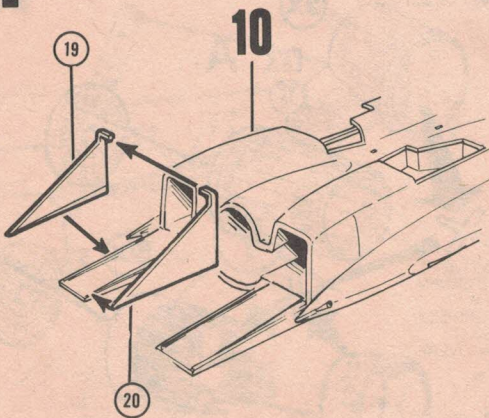

12

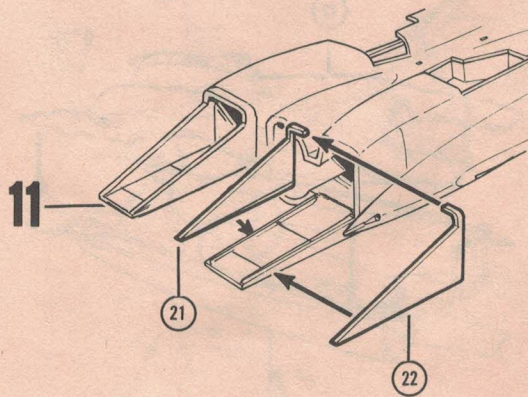

13

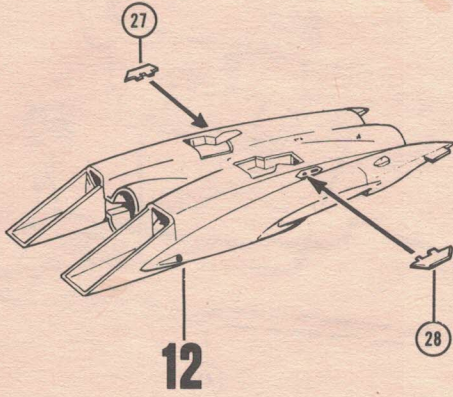

14

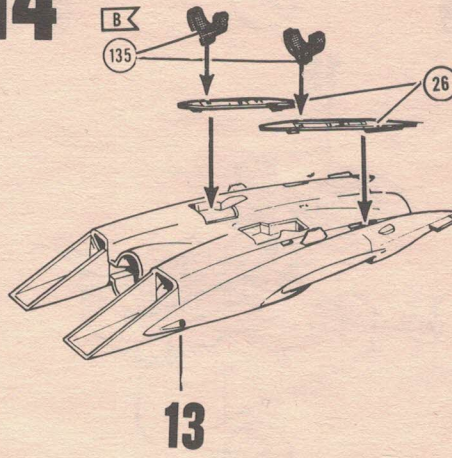

15

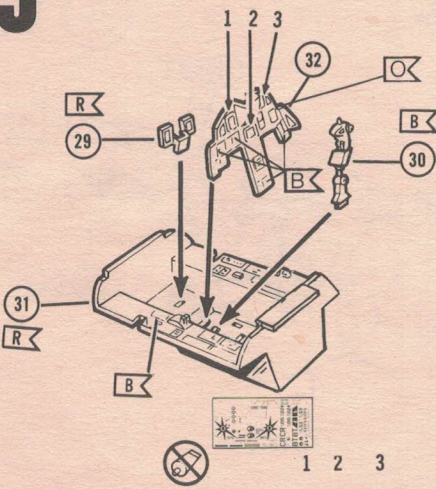

16

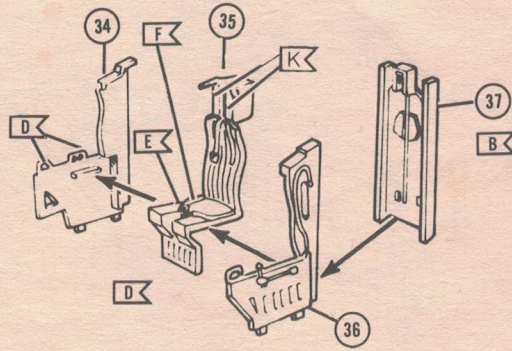

17

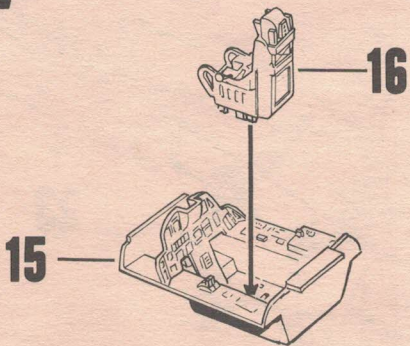

18

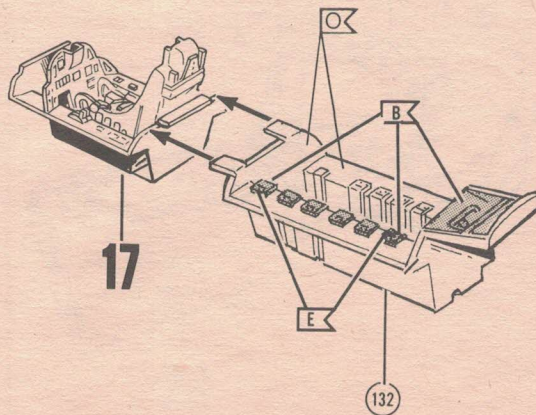

# 19

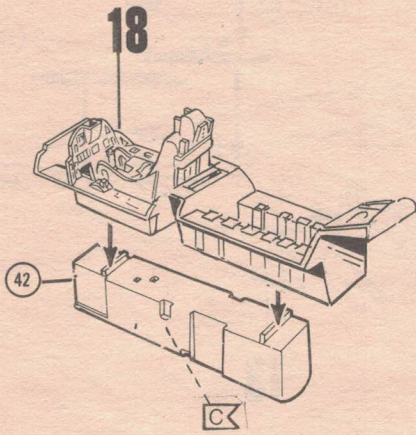

# 20

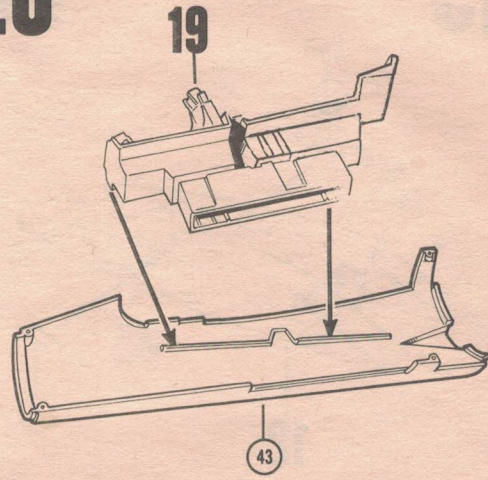

# 21

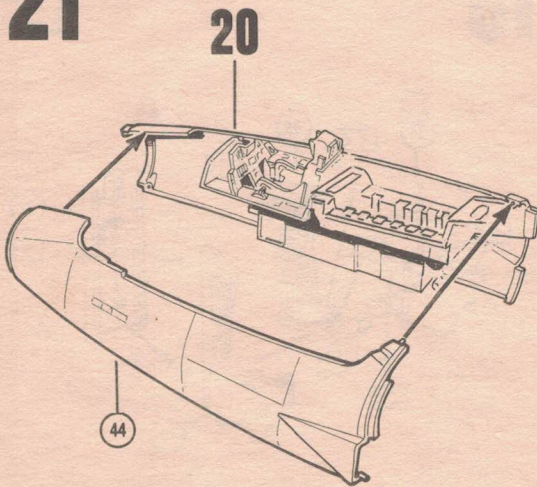

# 22

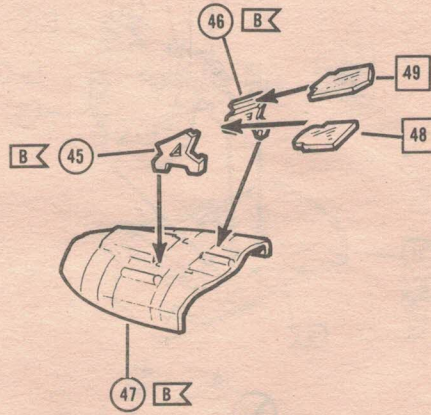

# 23

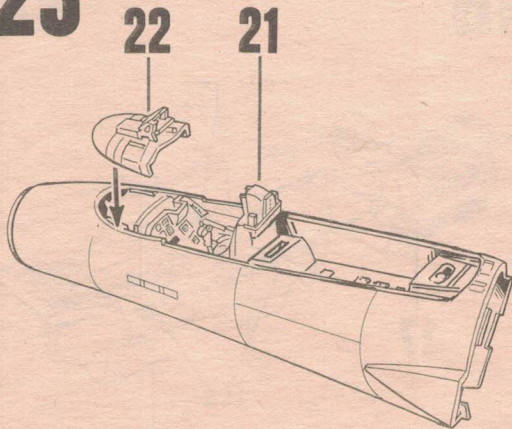

# 24

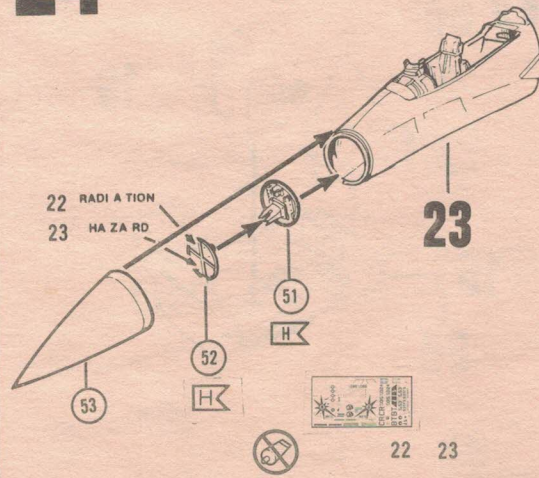

# 25

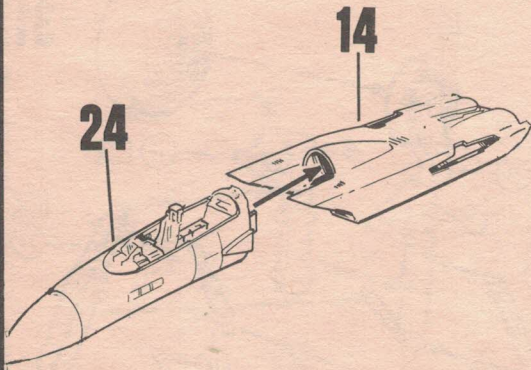

# 26

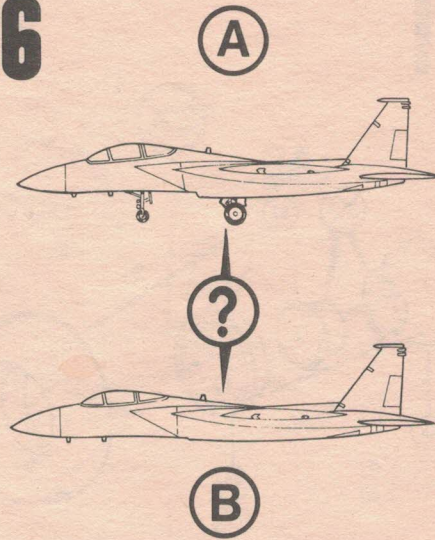

# 27 (A)

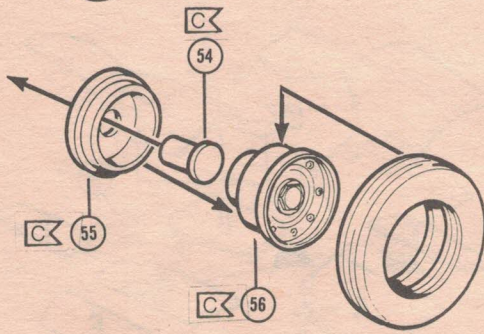

# 28

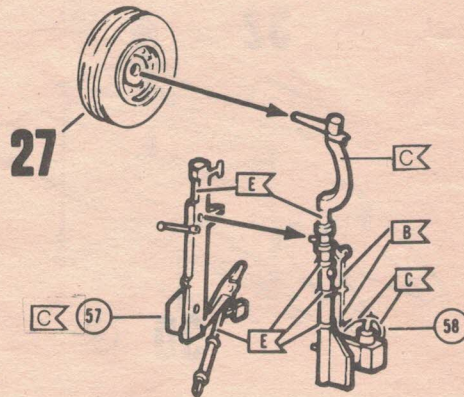

# 29

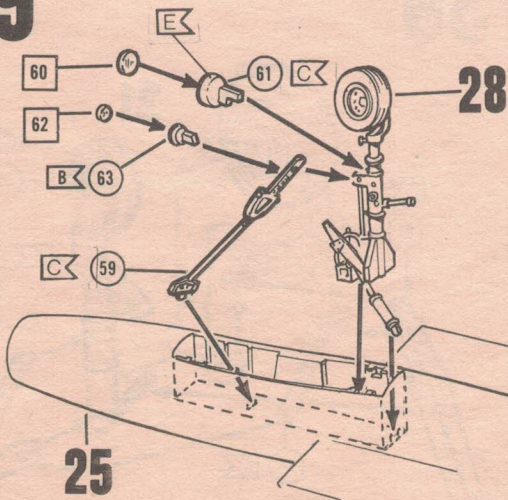

# 30

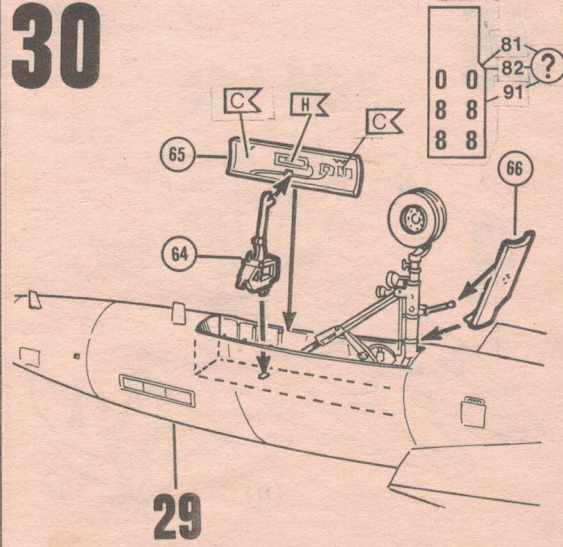

# 31

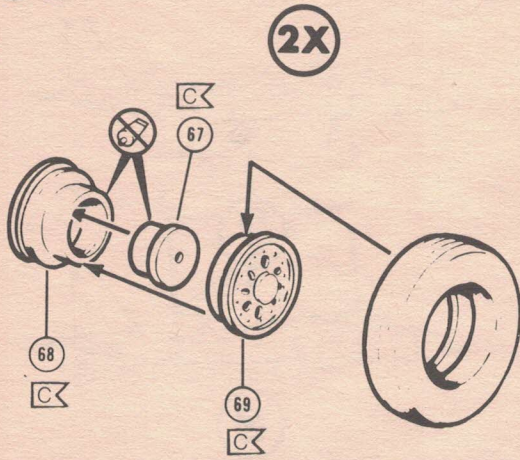

# 32

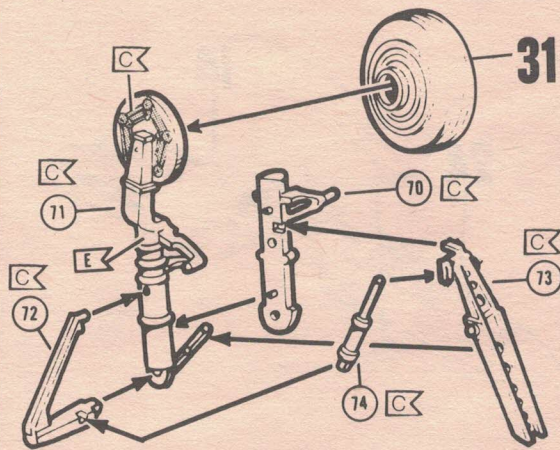

# 33

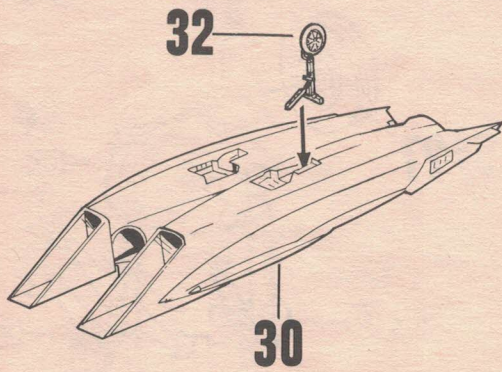

# 34

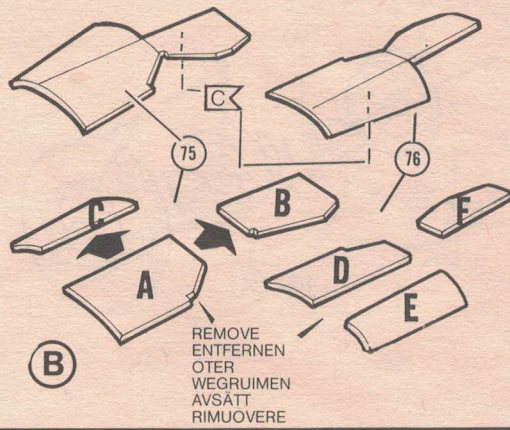

# 35

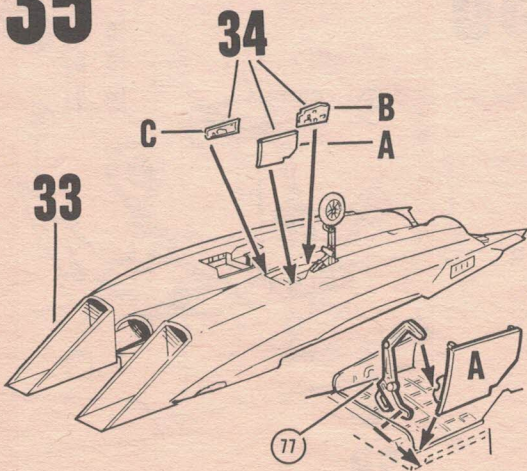

# 36

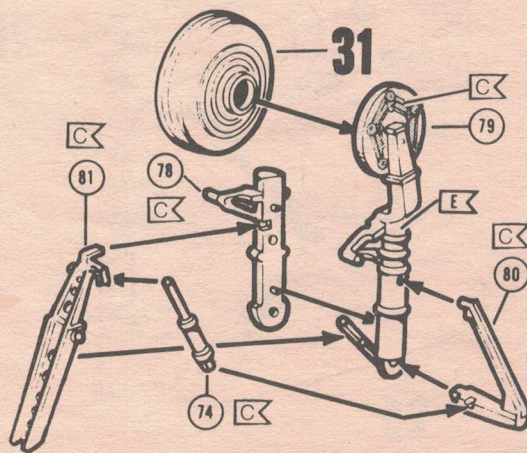



37

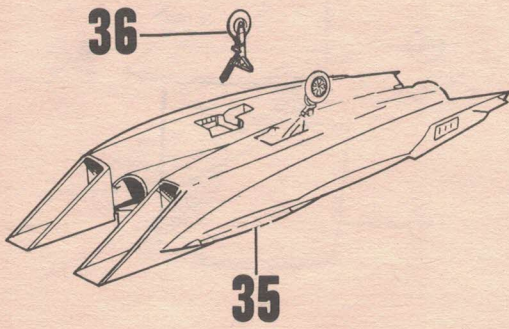

38

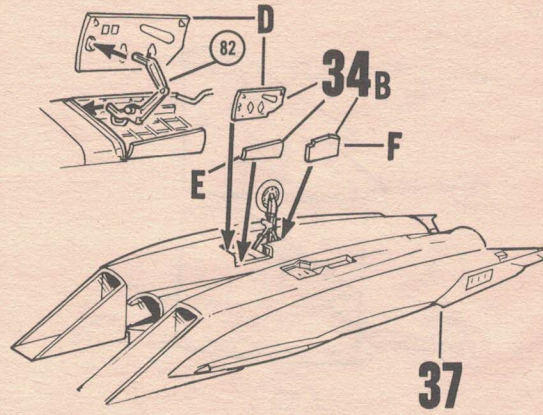

39 (B)

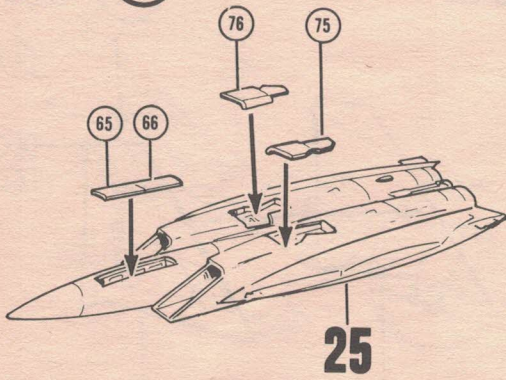

40

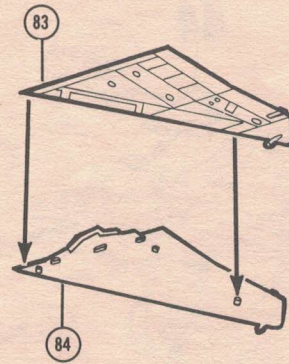

41

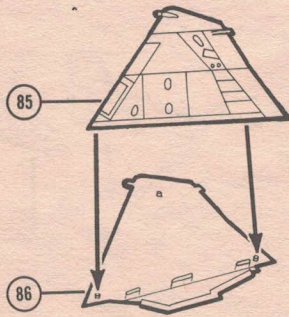

42

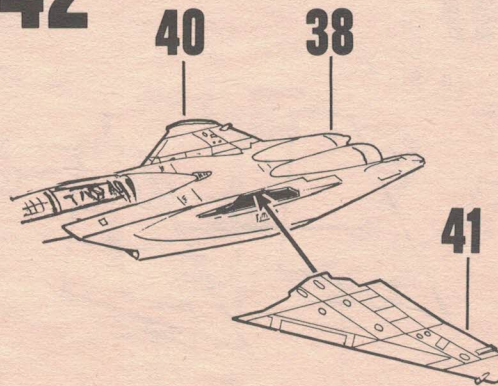

# 43

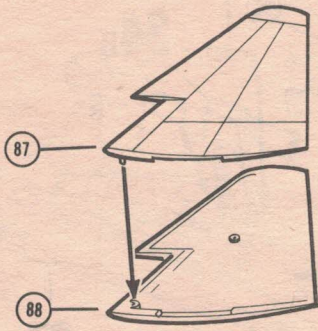

# 44

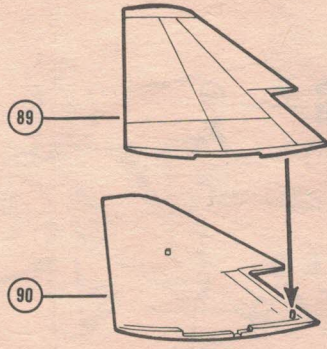

# 45

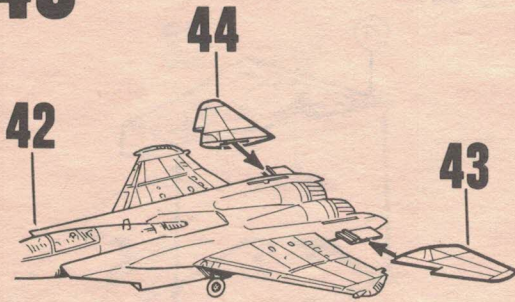

# 46

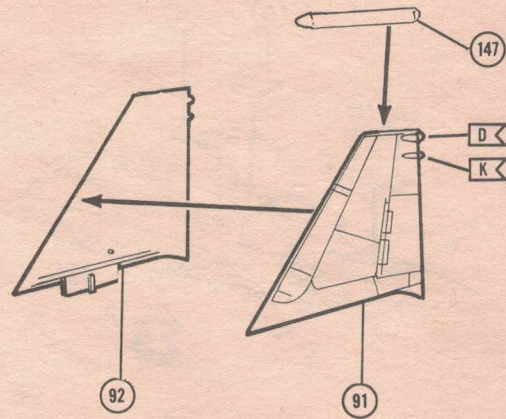

# 47

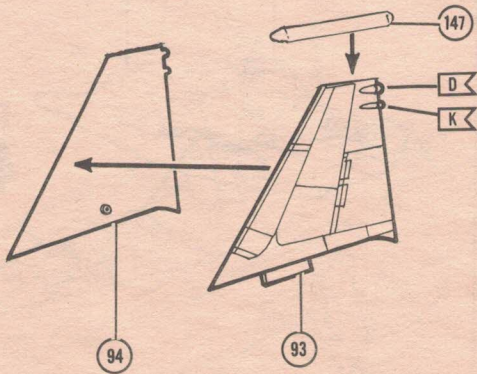

# 48

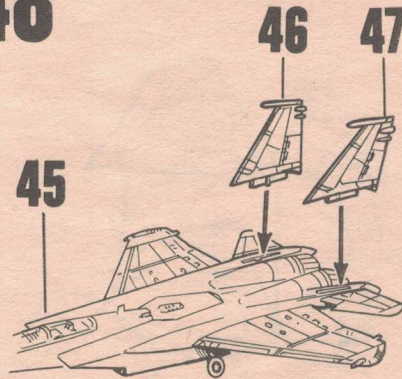

# 49

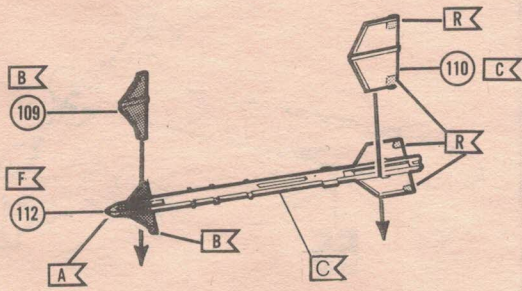

4X

# 50

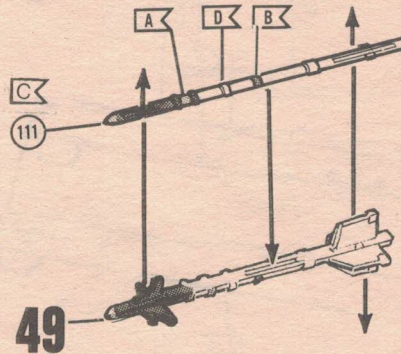

4X

# 51

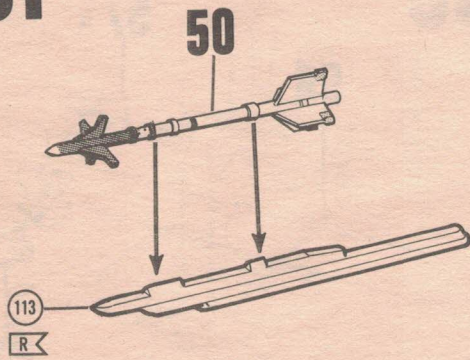

4X

# 52

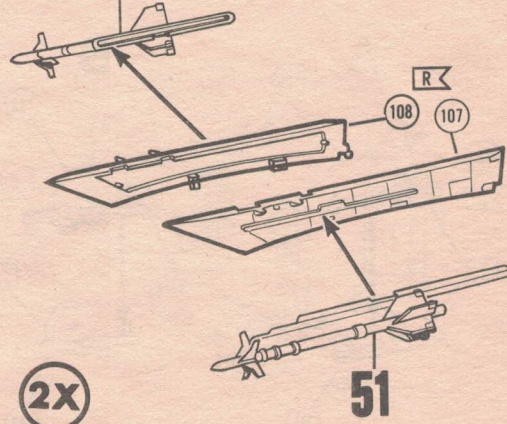

2X

# 53

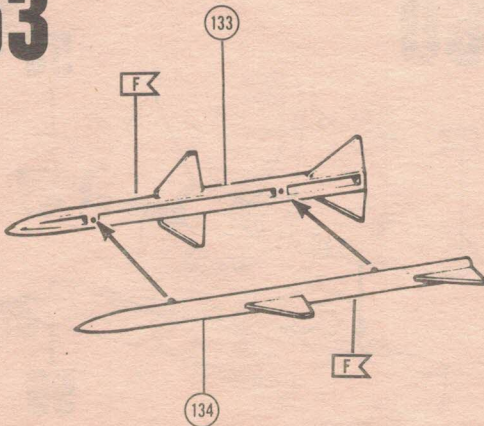

4X

# 54

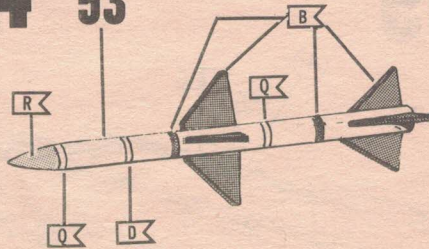

4X

# 55

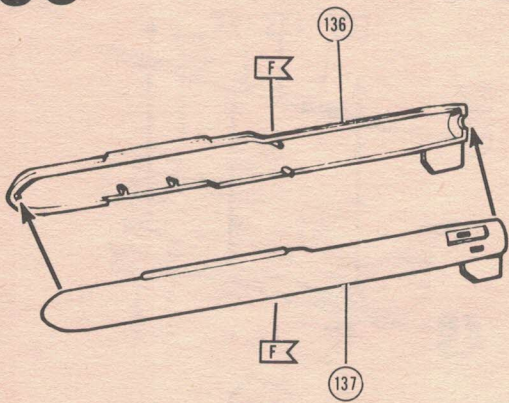

# 56

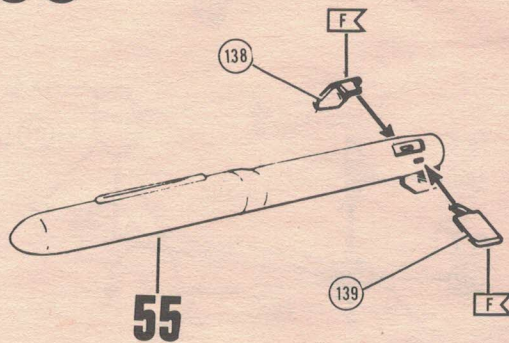

# 57

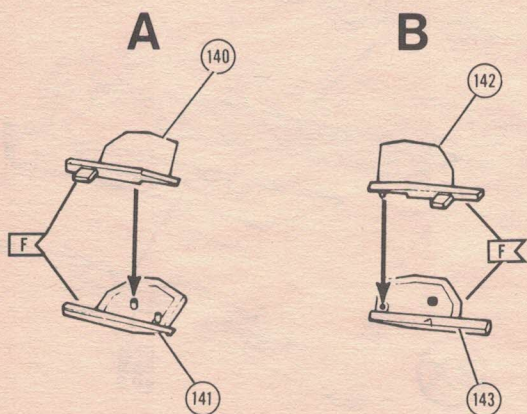

# 58

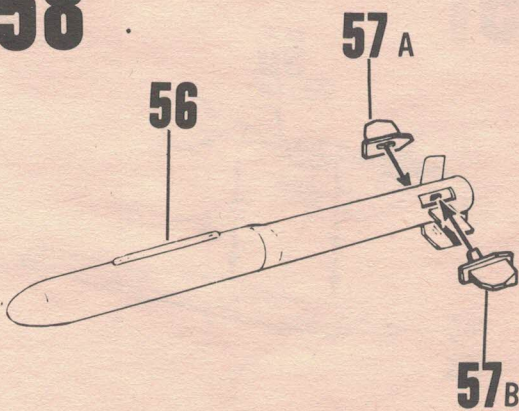

# 59

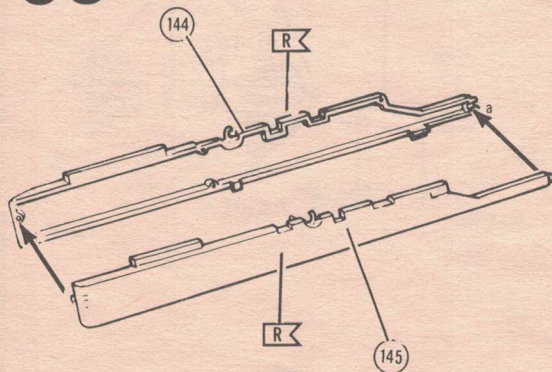

# 60

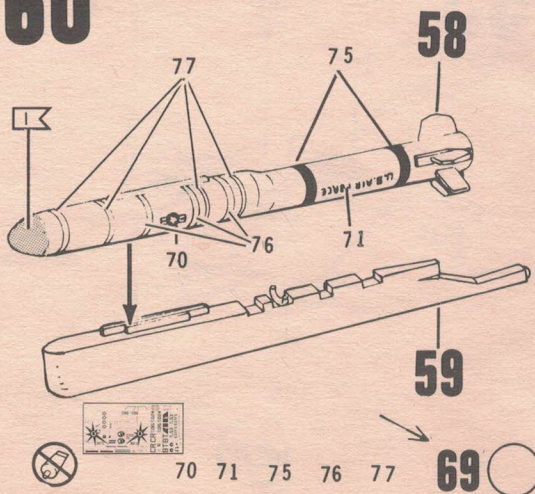

# 61

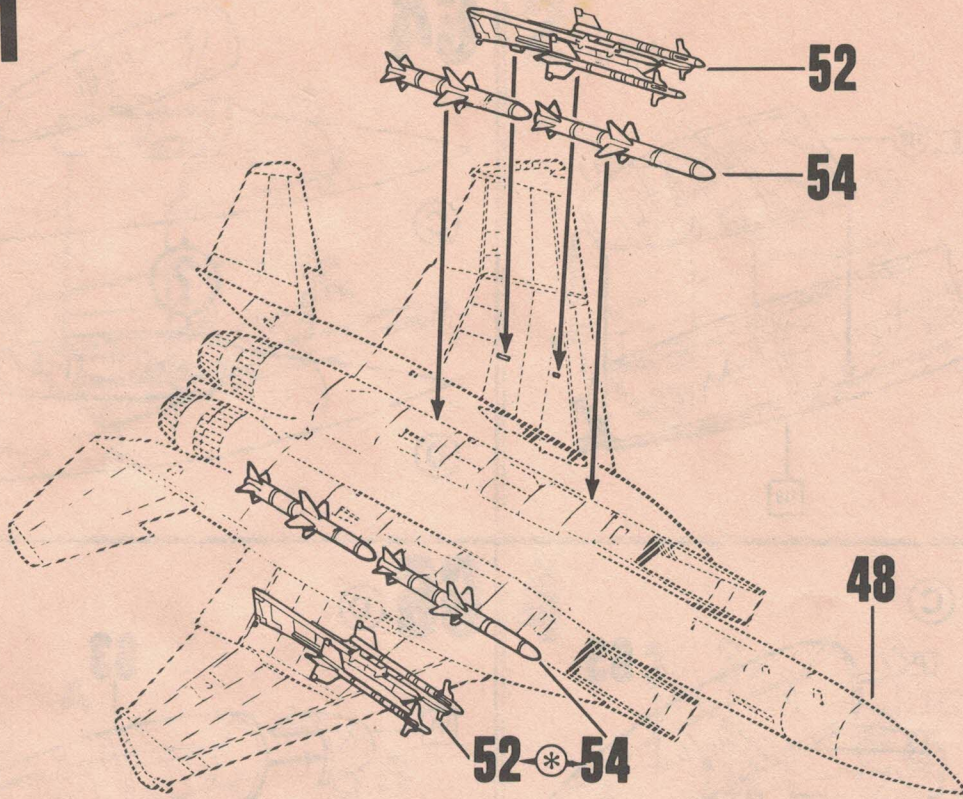

# 62

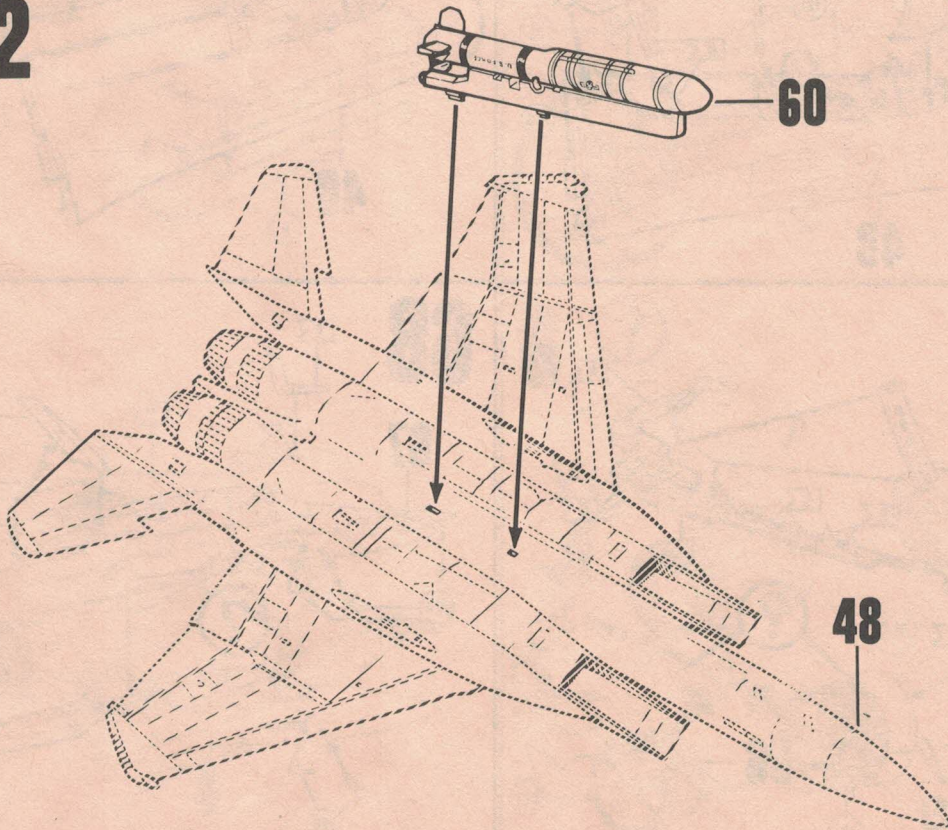

# 63

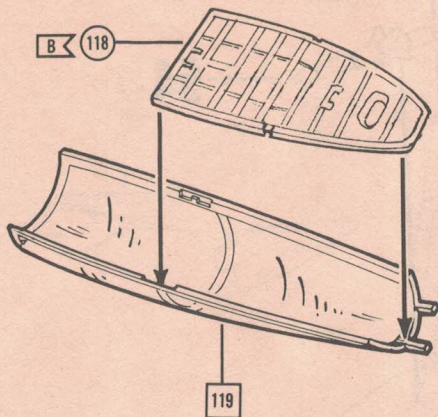

# 64

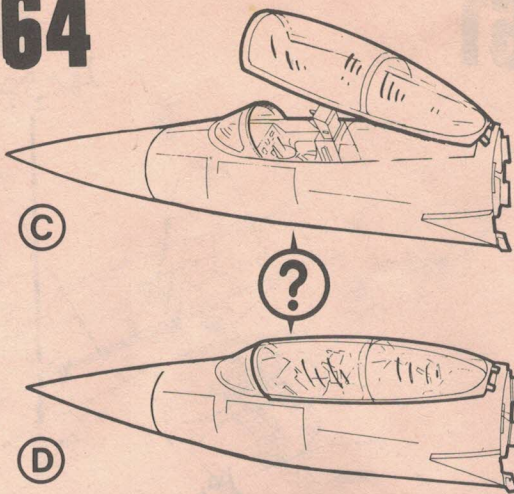

# 65 C

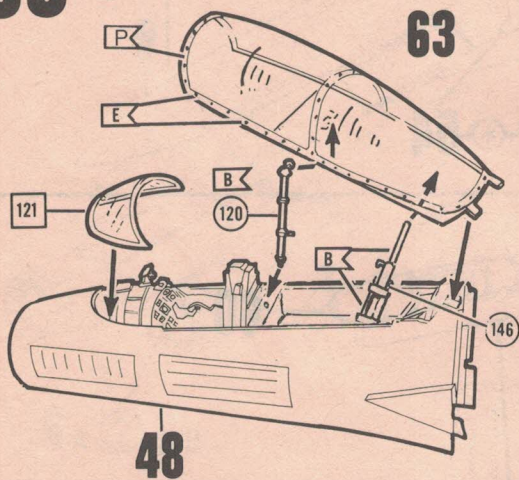

# 66 D

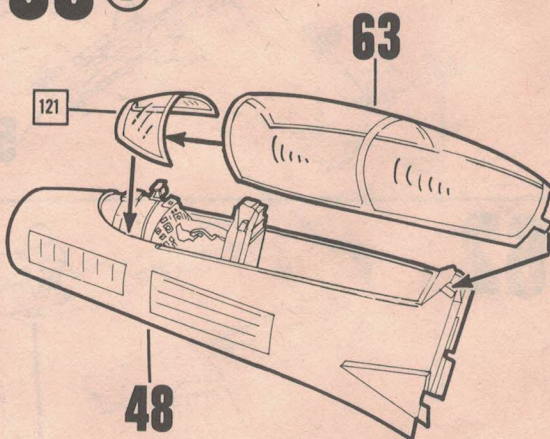

# 67

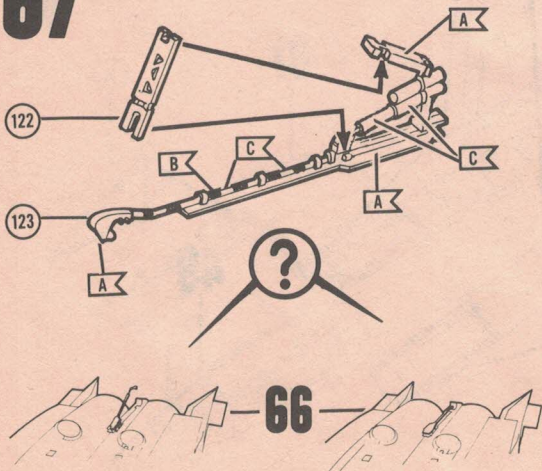

# 68

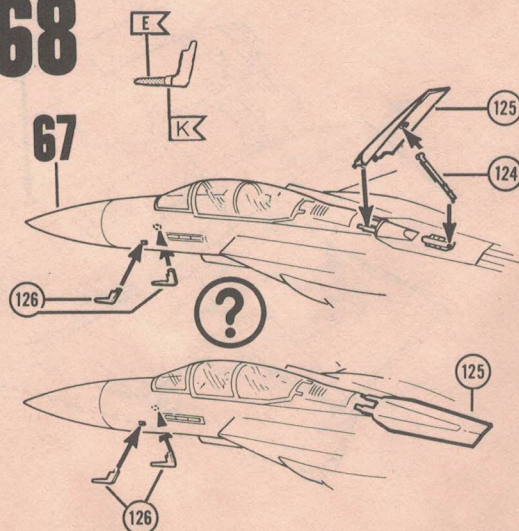

69

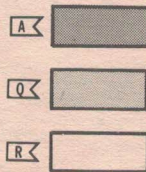
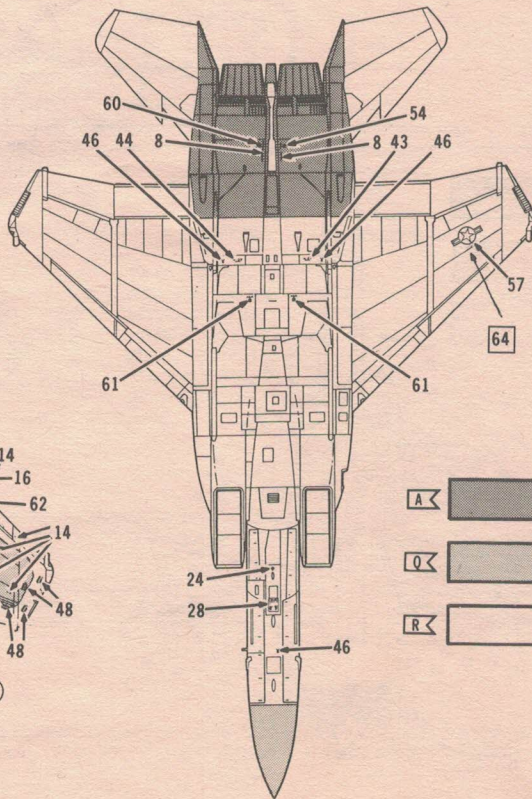
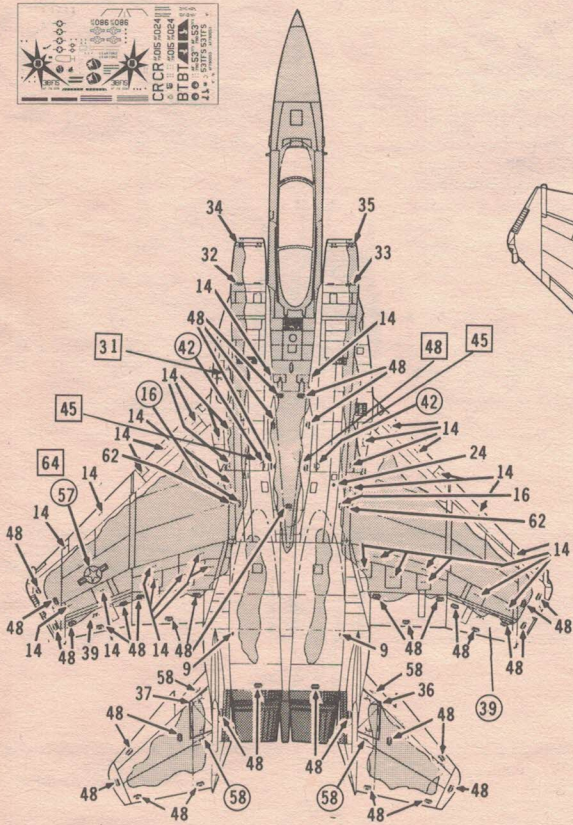
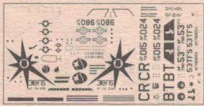
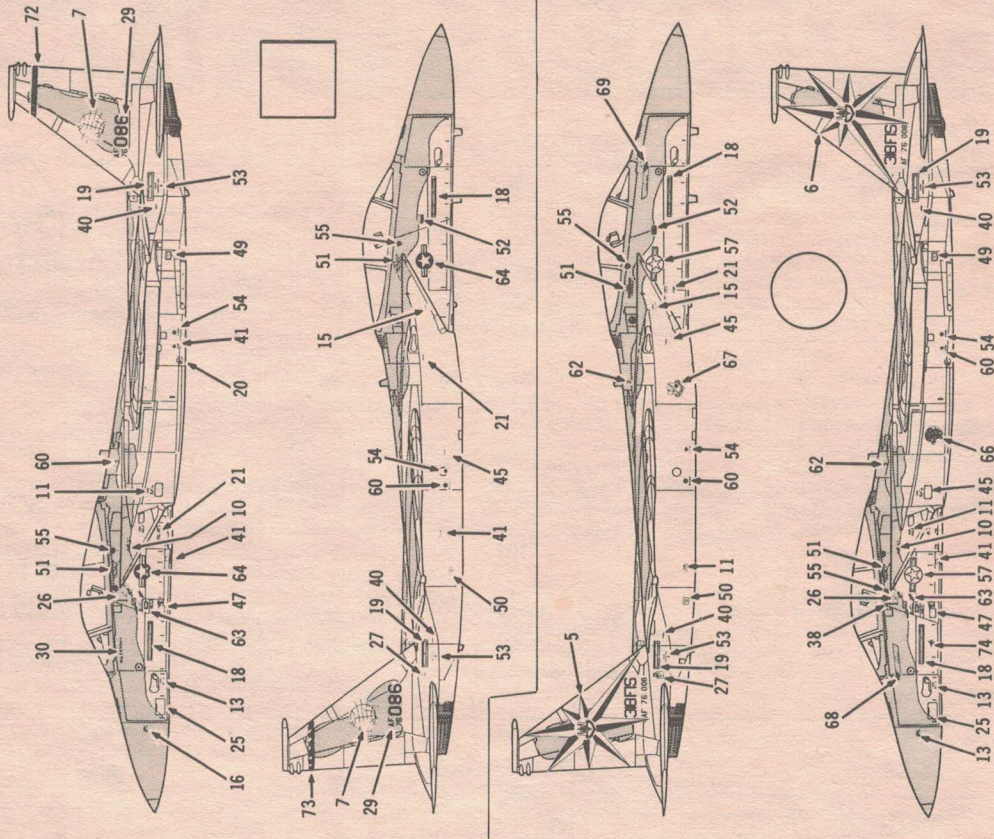

# 70

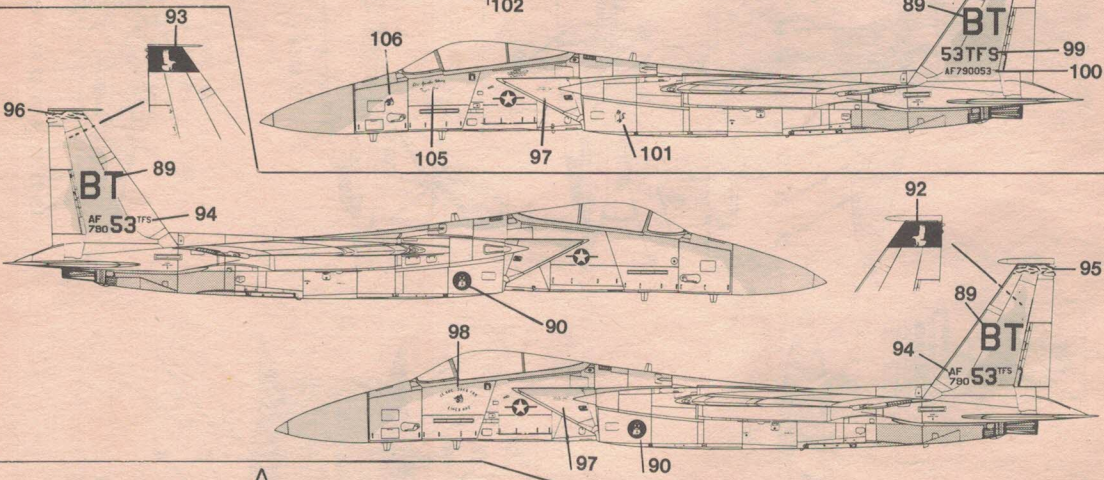
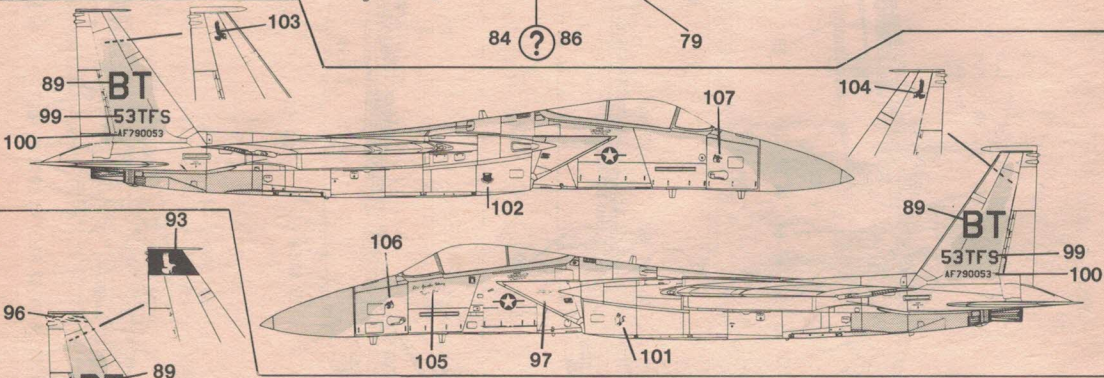
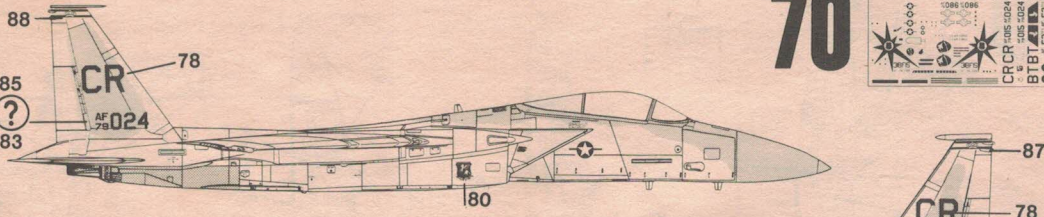
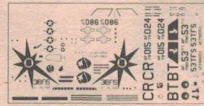

- A [shaded box]
- Q [shaded box]
- R [white box]

