



ACADEMY
MINICRAFT
 MODEL KITS

McDONNELL DOUGLAS F-15C EAGLE

1/48 scale

The modern jet fighter has become a technological wonder, filled with complex electronic gear. The current role of the fighting plane has become so far removed from its original concept that it bears almost no resemblance to the typical combat situations of World War II. We learned in Vietnam that our highly sophisticated, missile-armed fighters were often at a disadvantage when engaging the more nimble MiG-21, for example and the need for cannon armament was clearly demonstrated. In aerial conflicts we learned that supersonic speed is not nearly as advantageous as fast response and maneuverability.

To address these problems, the F-15 Eagle was designed specifically to reprise the role of "dogfighter". To do this, the basic engineering was directed toward lower maintenance time by using less complicated systems. Maintaining the Eagle takes about half the time it takes for a Phantom II, yet the F-15 retains essential automatic controls, such as engine inlet positioning. The Eagle's twin Pratt & Whitney F100 afterburning turbofans produce 10,000 more pounds of thrust than the weight of the plane. This allows the F-15 to turn tightly without sacrificing precious airspeed. The Eagle carries one 20mm rotary cannon as standard equipment, but eight hardpoints can carry an enormous variety of additional weaponry to enhance the dogfighting abilities of the plane. The single-seat F-15C is the second generation version of the single seat Eagle and replaced the F-15A in June, 1979. Externally, it shows little change, but inside it contains newer and more versatile electronics making today's Eagle far more deadly.



Cement Parts
 Coller
 Kleben
 Pegar
 Incollare
 Colar
 Kleven



DO NOT cement
 Ne pas coller
 Nicht kleben
 No pegar
 Non incollare
 Nao colar
 Niet kleven



Cut away
 Couper
 Scheiden
 Cortar
 Tagliare
 Cortar
 Snijden



Optional parts
 Choix
 Auswahlmöglichkeit
 Eleccion
 Scelta
 Opcao
 Keuze



3

Repeat operation
 Répéter l'opération
 Vorgang wiederholen
 Repetir la operacion
 Ripetere
 Repetir a operação
 Herhalen

1 EJECTION SEATS AND COCKPIT

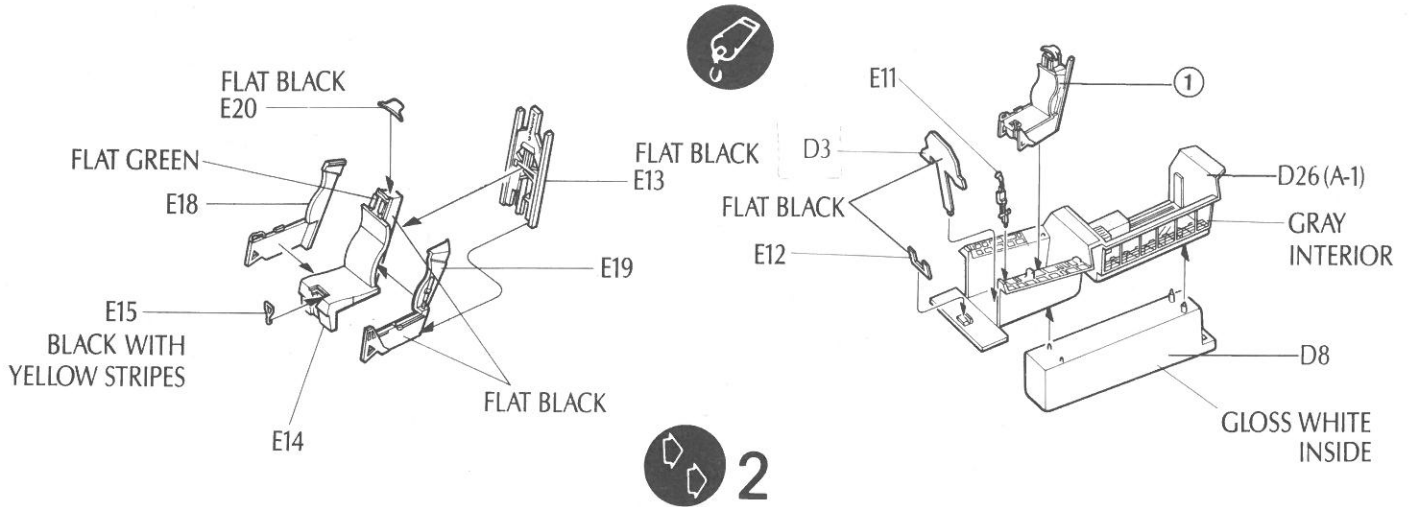

2 NOSE ASSEMBLY

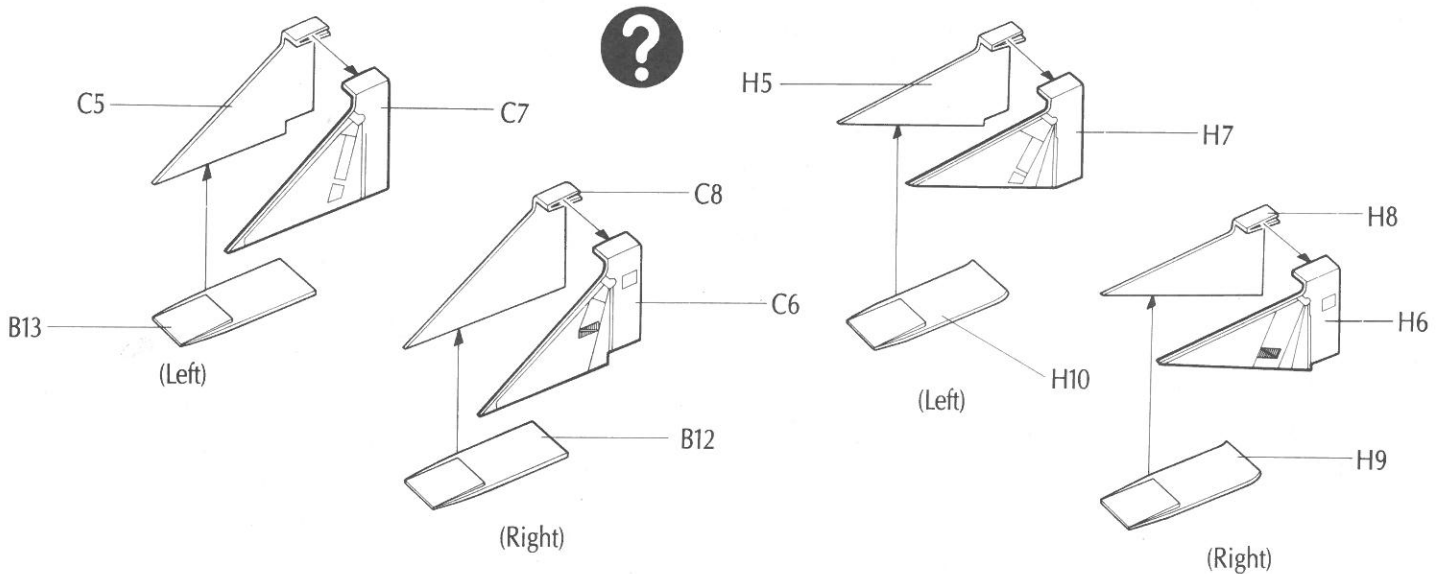

3 INTAKE ASSEMBLIES (A)

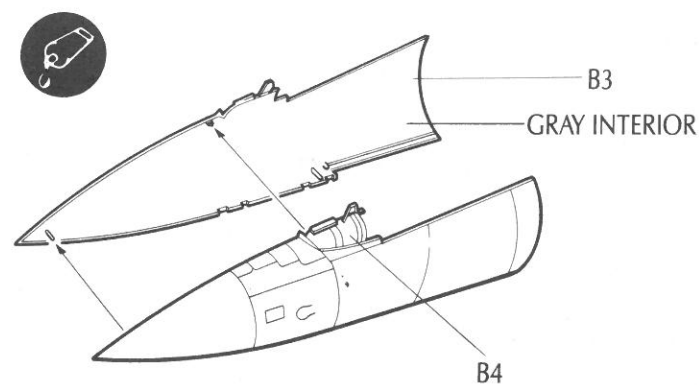

4 COCKPIT AND NOSE WHEEL INSTALLATION

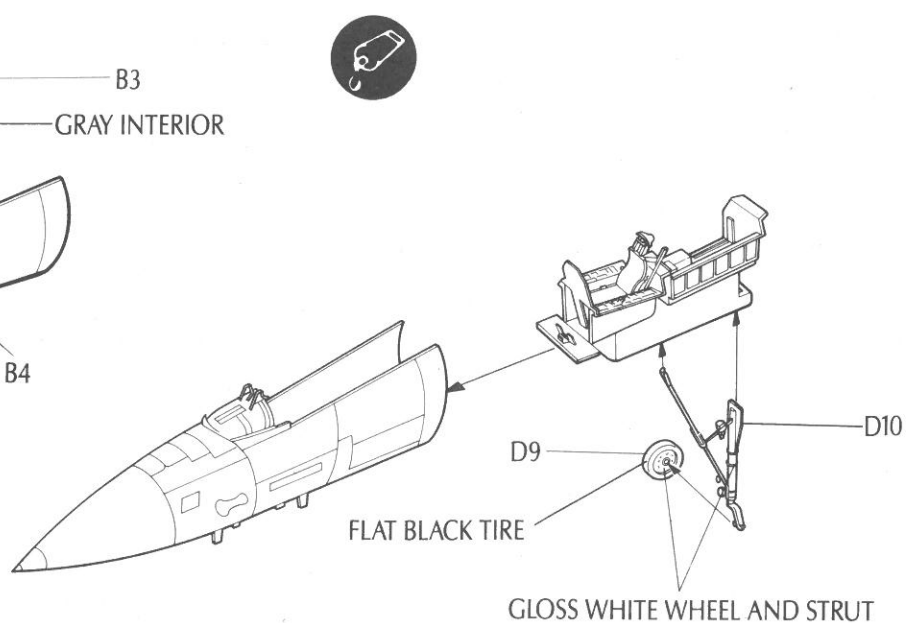

5 ENGINES

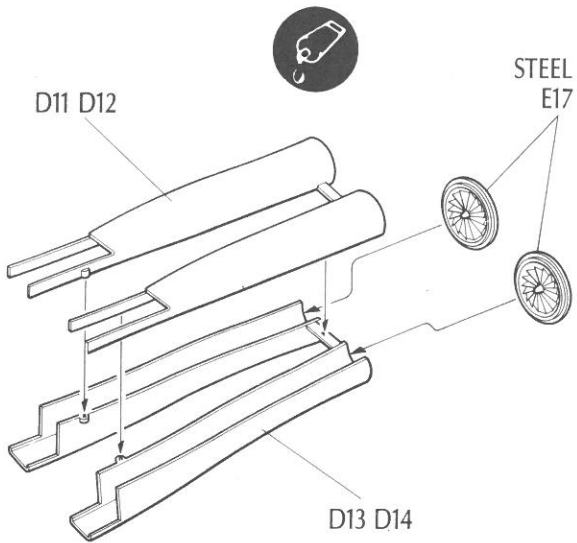

6 ENGINE INSTALLATION

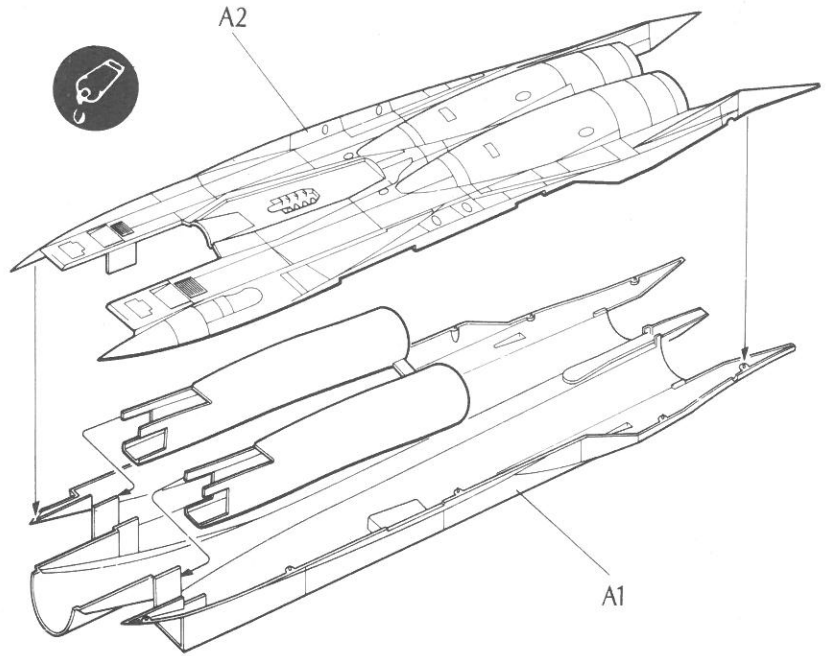

7 WING ASSEMBLY

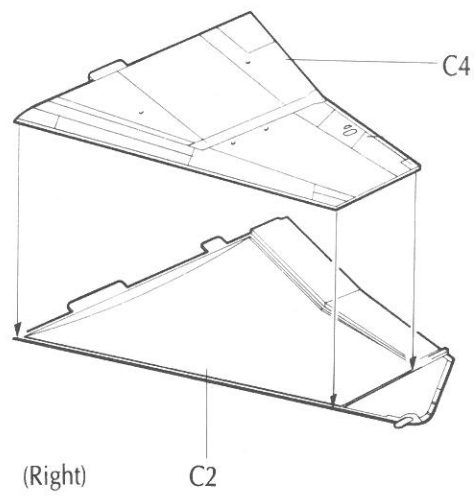
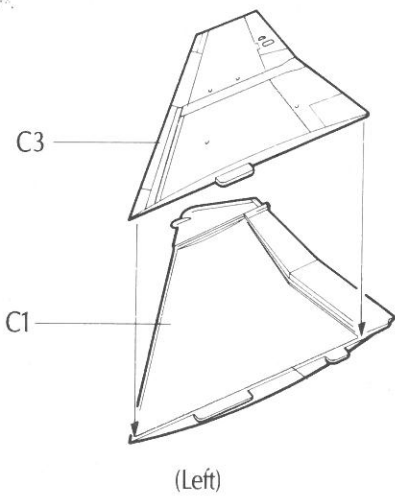

8 AFTERBURNERS

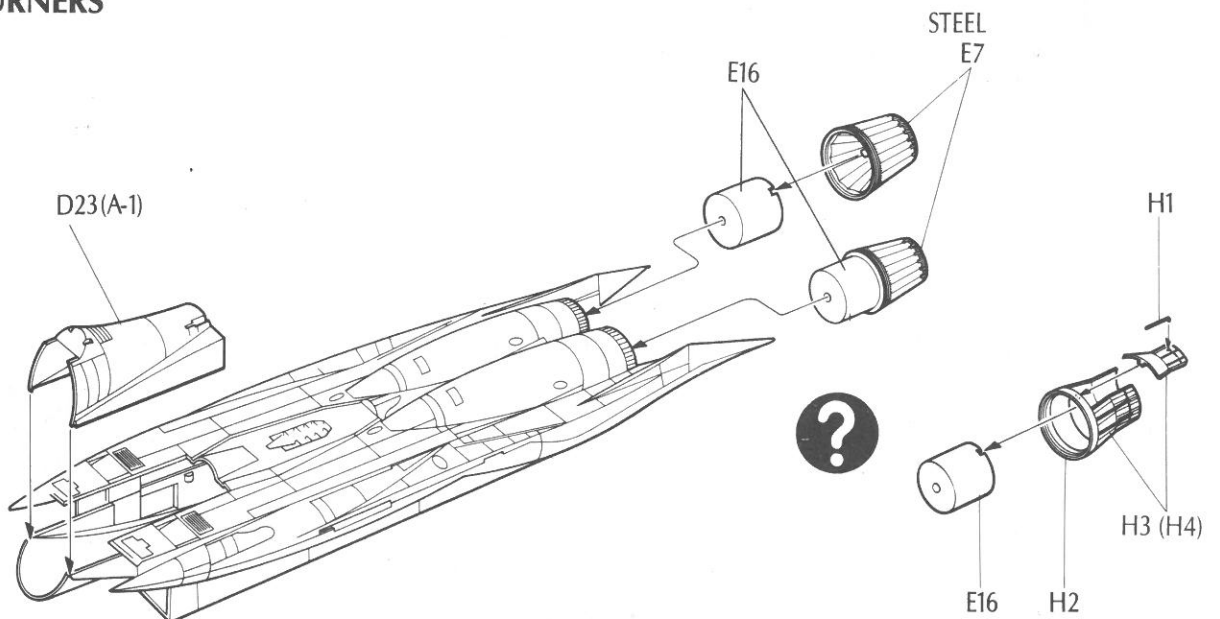

9 WING AND TAIL ASSEMBLIES

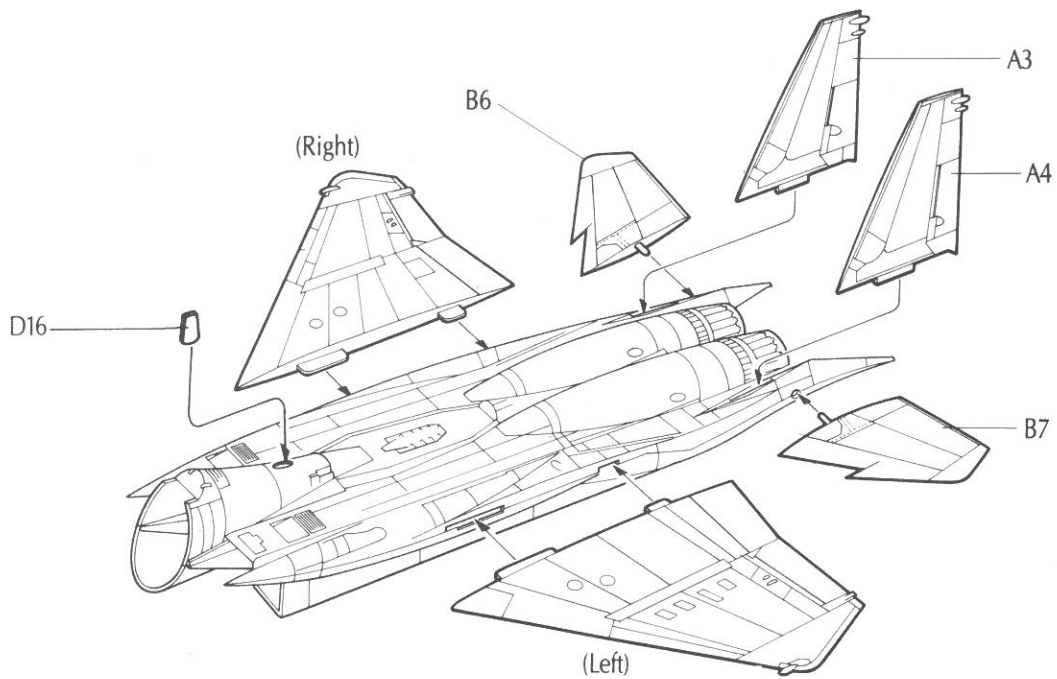

10 NOSE INSTALLATION

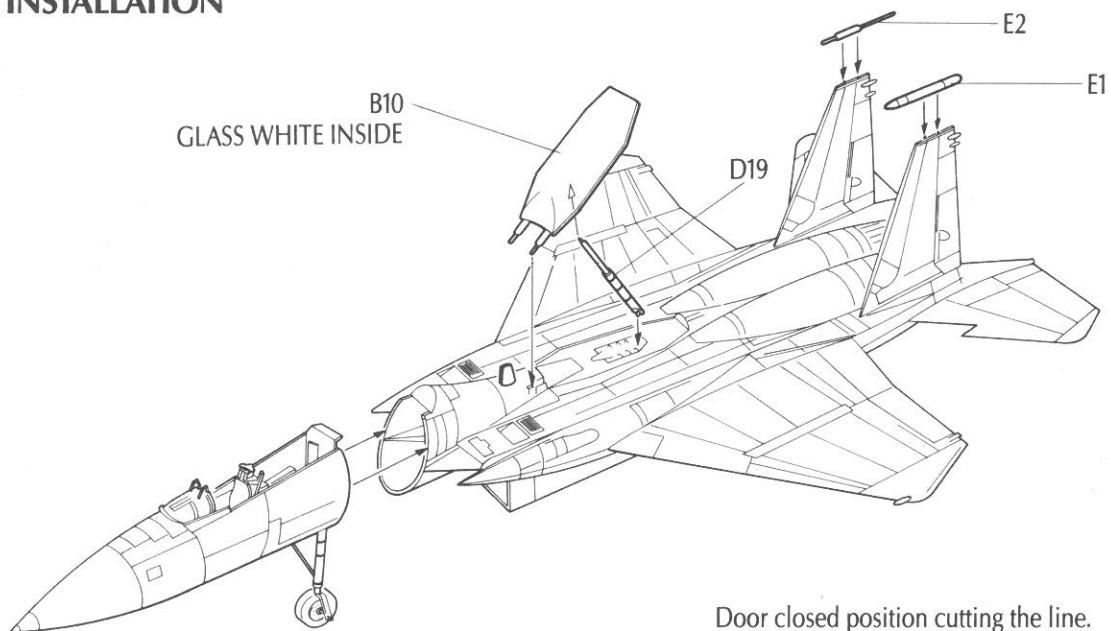

11 INTAKE ASSEMBLIES (B)

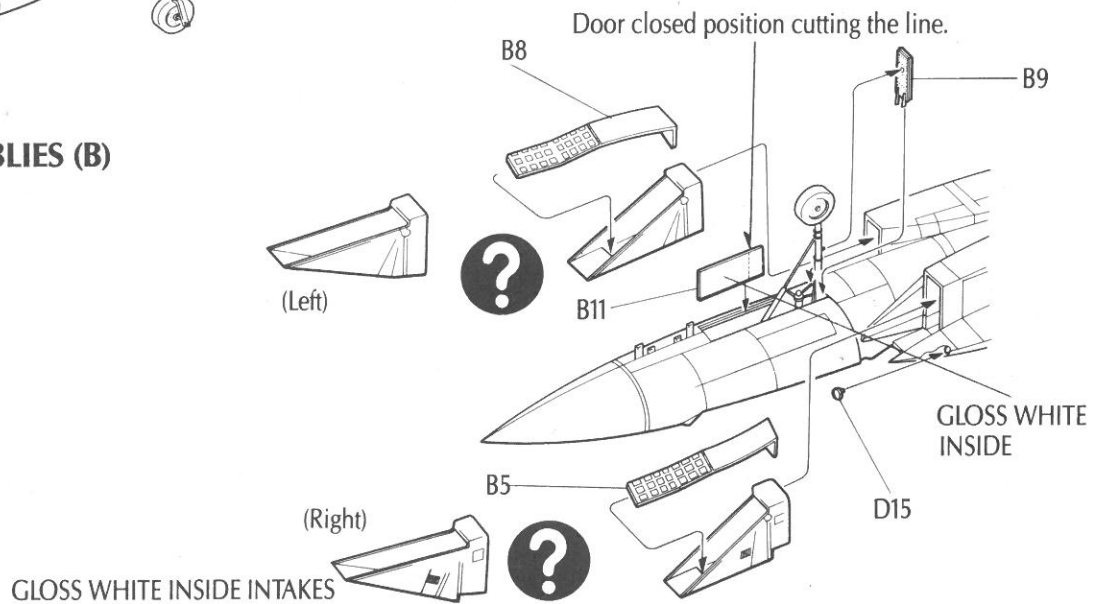

12 MAIN GEAR INSTALLATION

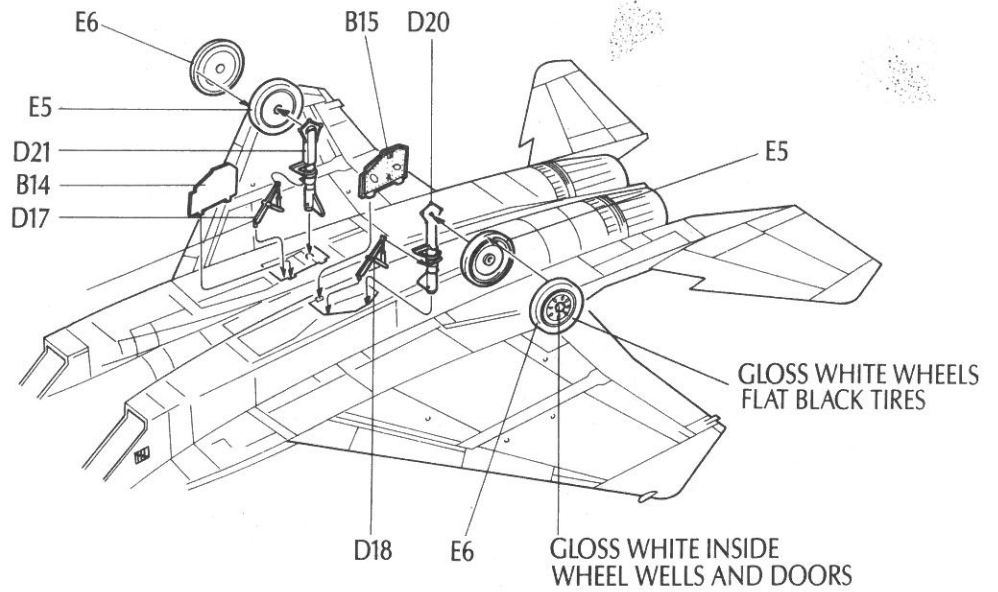

13 SIDEWINDER AND SPARROW



4

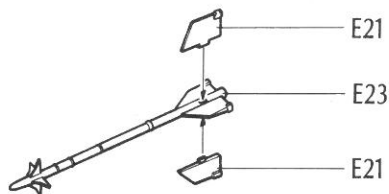

ALL WHITE

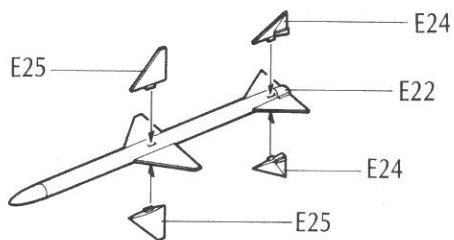

14 SIDEWINDER PYLONS



2

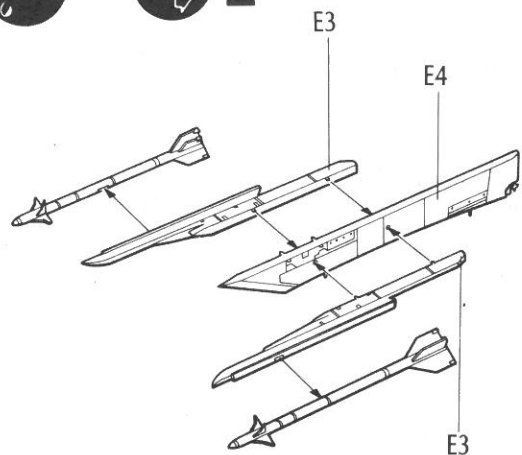

15 PYLON MOUNTING

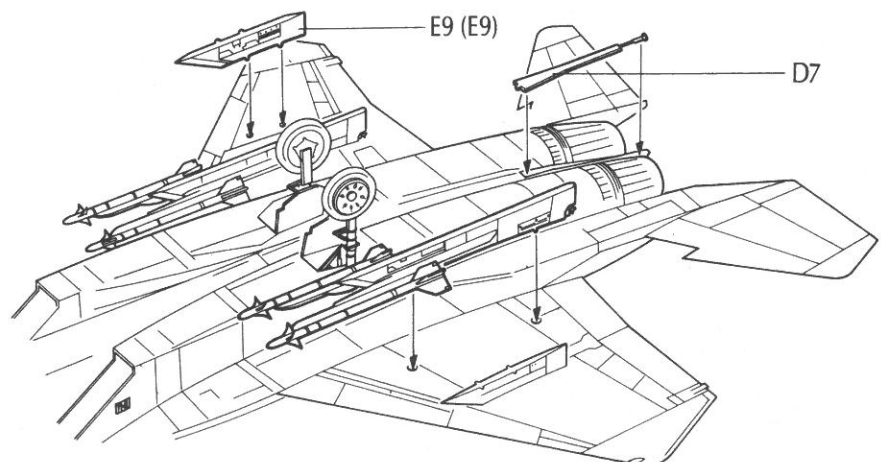

16 FINAL ASSEMBLY

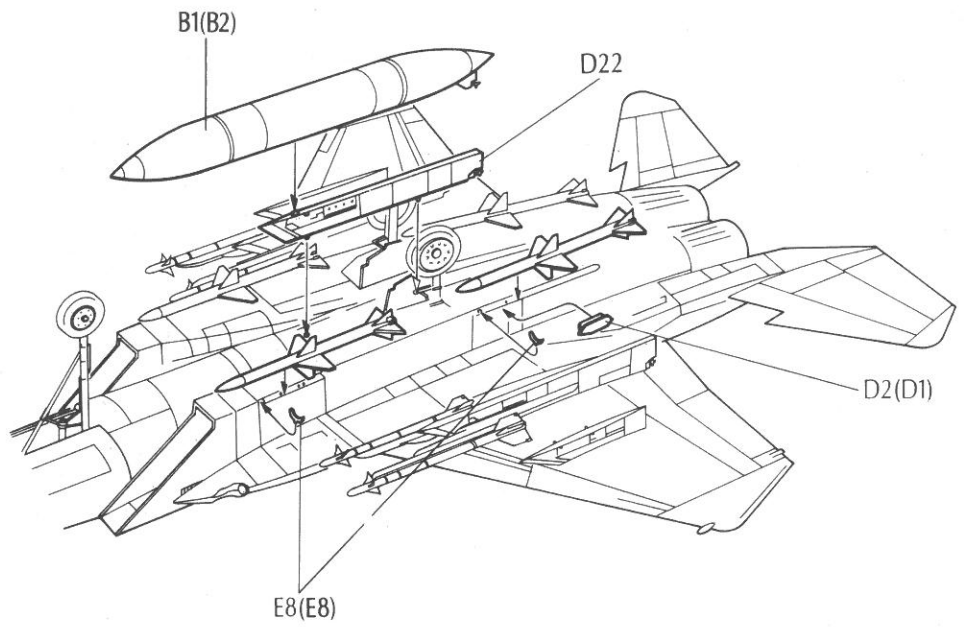

17 CANOPY INSTALLATION



E8

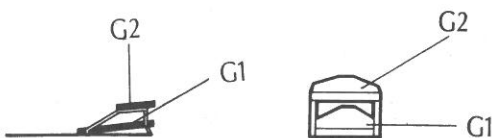
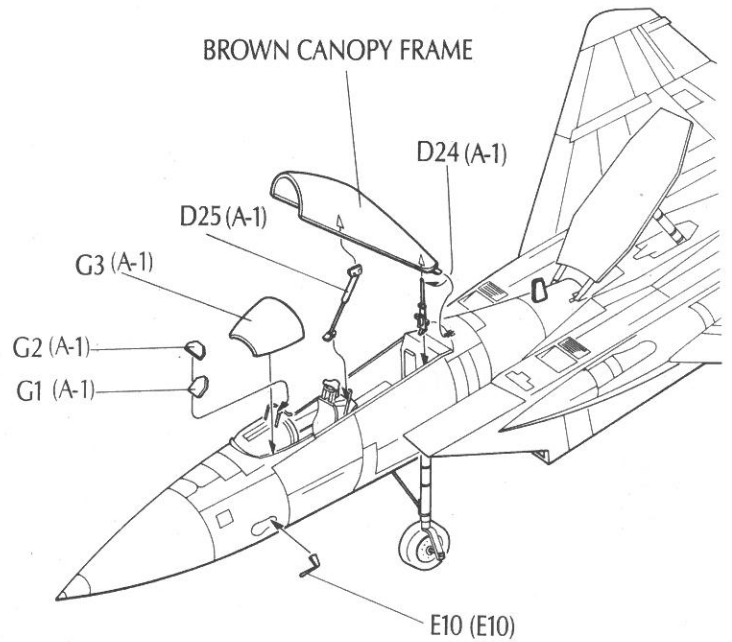
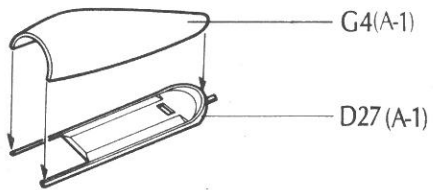

DECAL LOCATIONS AND PAINTING INSTRUCTIONS

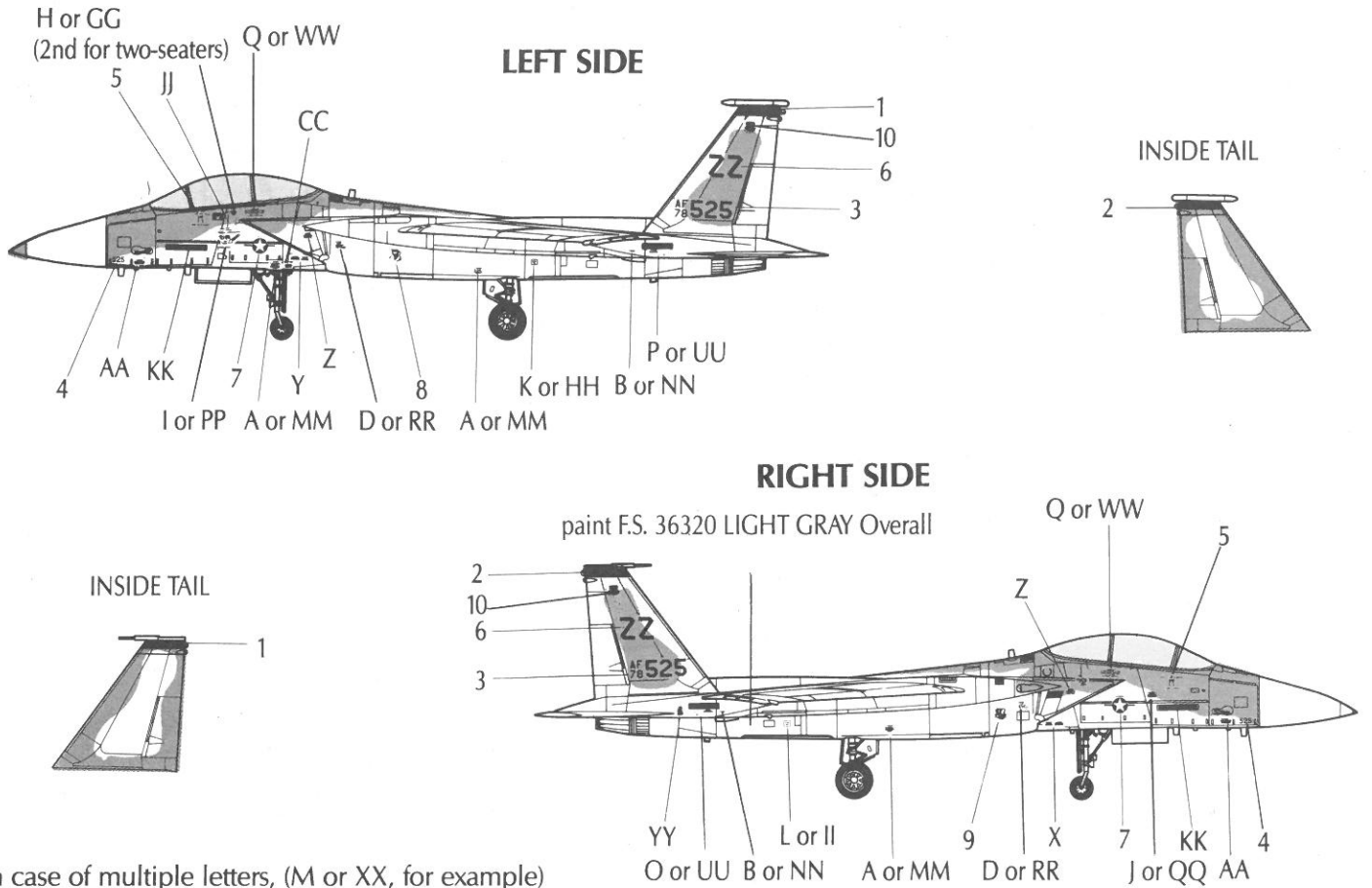

In case of multiple letters, (M or XX, for example) the first letter designates markings for the ground attack (dark gray) scheme, the second letters indicate the markings for the Ghost Gray scheme. Where no choice is given, the decal is common to both schemes.

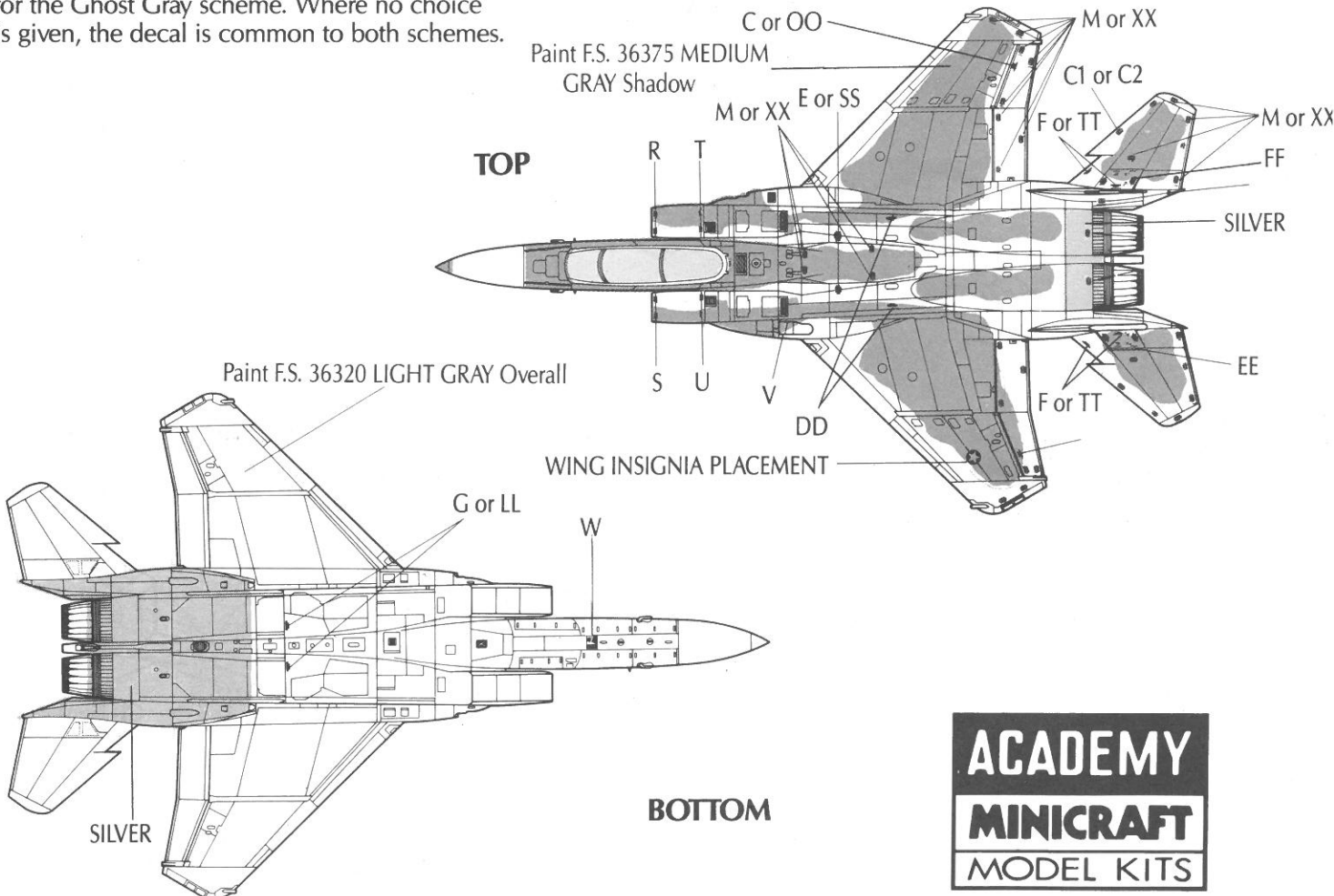

PARTS LOCATING DIAGRAM

A

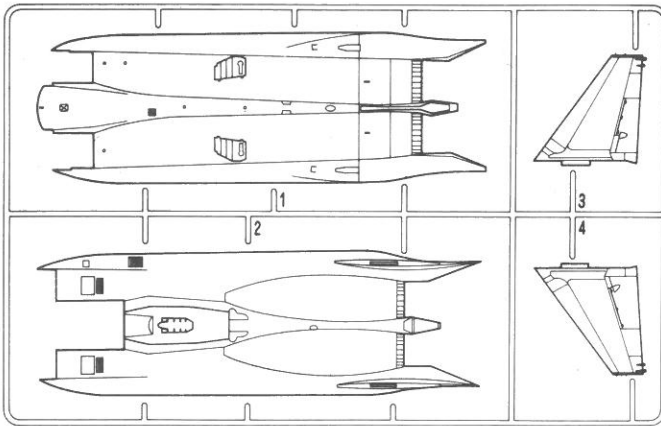

B

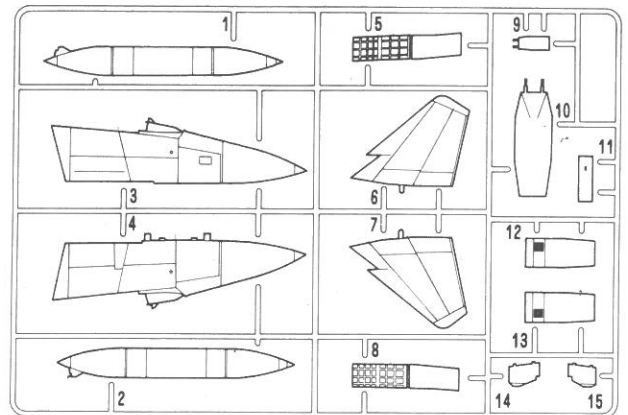

C

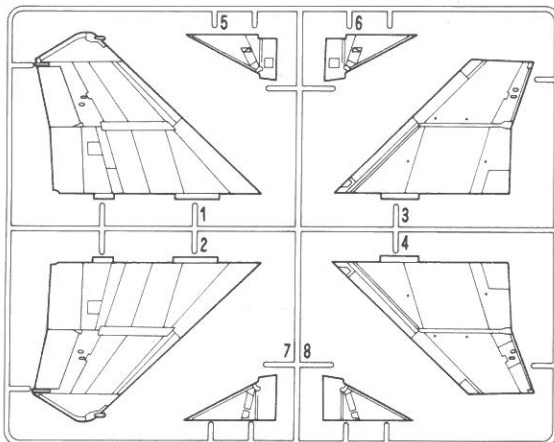

D

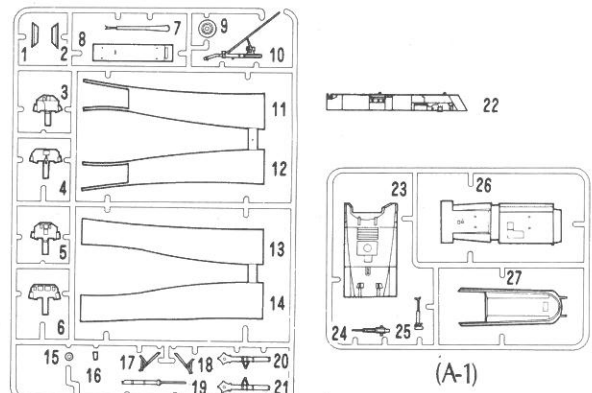

E

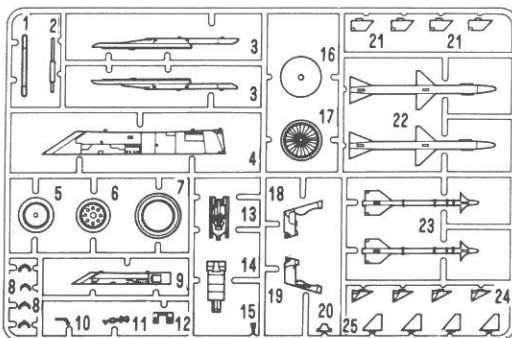

H

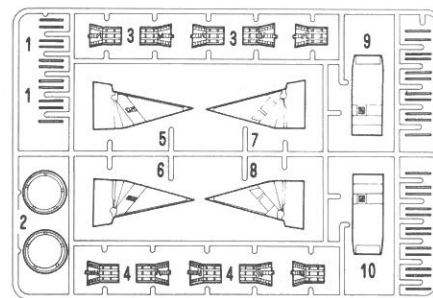

G

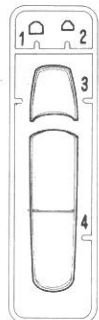

(A-1)

| ENGLISH | FRENCH | GERMAN | SPANISH | ITALIAN |
|----------|-----------|-----------------|-----------|-----------|
| WHITE | BLANCO | WEISS | BLANC | BIANCO |
| YELLOW | JAUNE | GELB | AMARILLO | GIALLO |
| RED | ROUGE | ROT | ROJO | ROSSO |
| BLUE | BLEU | BLAU | AZUL | BLU |
| GRAY | GRIS | GRAU | GRIS | GRIGIO |
| GUNMETAL | METALLIC | METALLIC | METALICO | METALLICO |
| GREEN | VERT | GRUN | VERDE | VERDE |
| SILVER | ARGENT | SILBERN | PLATA | ARGENTO |
| BLACK | NOIR | SCHWARZ | NEGRO | NERO |
| ORANGE | ORANGE | ORANGE | NARANJADO | ARANCIO |
| AMBER | AMBRE | BERNSTEINFARBEN | AMBAR | AMBRA |
| ALUMINUM | ALUMINIUM | ALUMINIUMFARBEN | ALUMINIO | ALLUMINIO |
| GLOSS | LUSTRE | GLANZENDES | BRILLANTE | BRILLANTE |
| FLAT | TERNE | GLANZLOSES | APAGADO | OPACO |

ACADEMY
MINICRAFT
MODEL KITS

©1990 Minicraft Models Inc.