

1:35 '39-'45 SERIES

# GERMAN RAILWAY FLATBED Typ Ommr (2 AXLE) w/MG CREW

 **DRAGON**

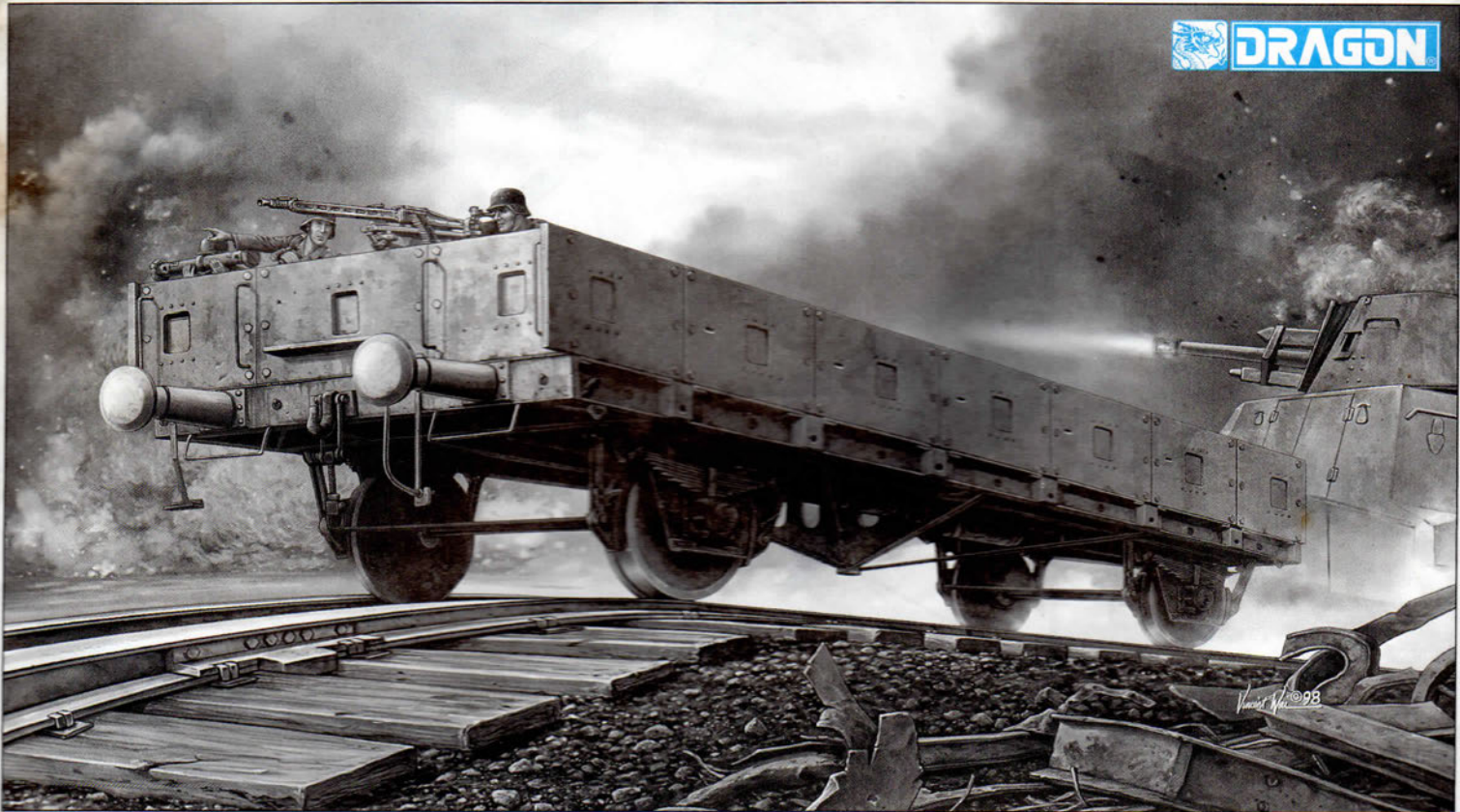

KIT NO: 6085

### Ax2

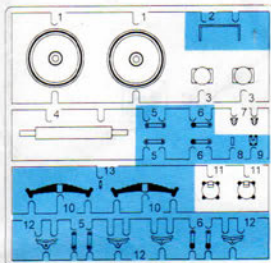

### Bx2

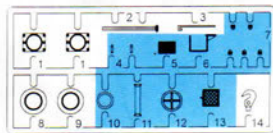

### C

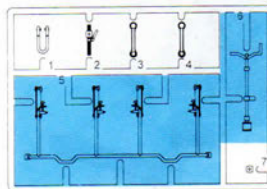

### Dx4

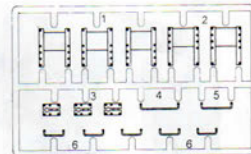

### Fx4

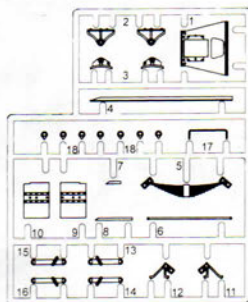

### Hx2

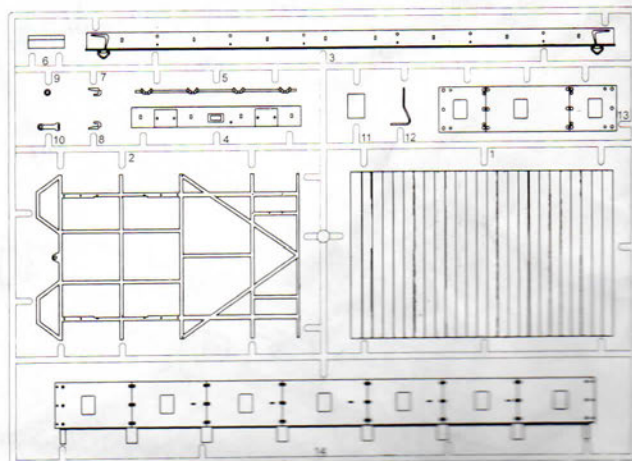

### E

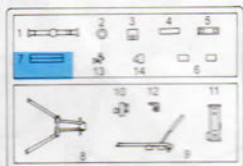

### G

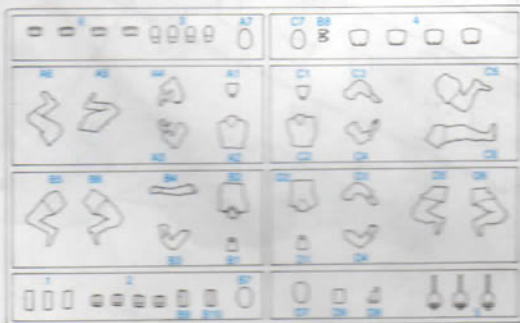
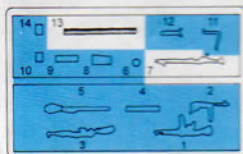
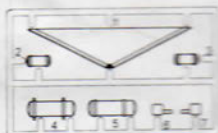



 此部分零件不用  
 Parts not for use.  
 Teile werden nicht verwendet.  
 Pieces à ne pas utiliser.  
 Parti non utilizzati.  
 此部分零件不用

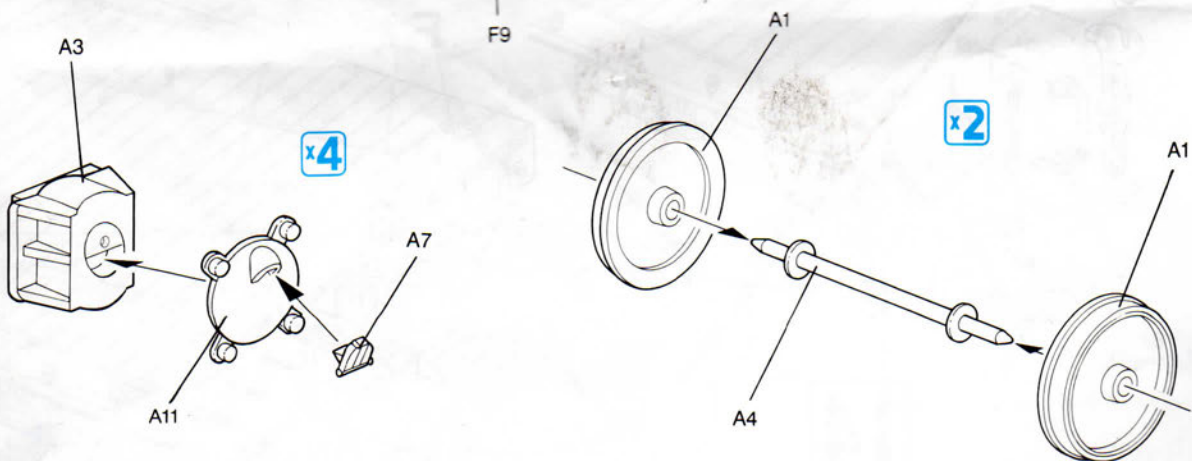
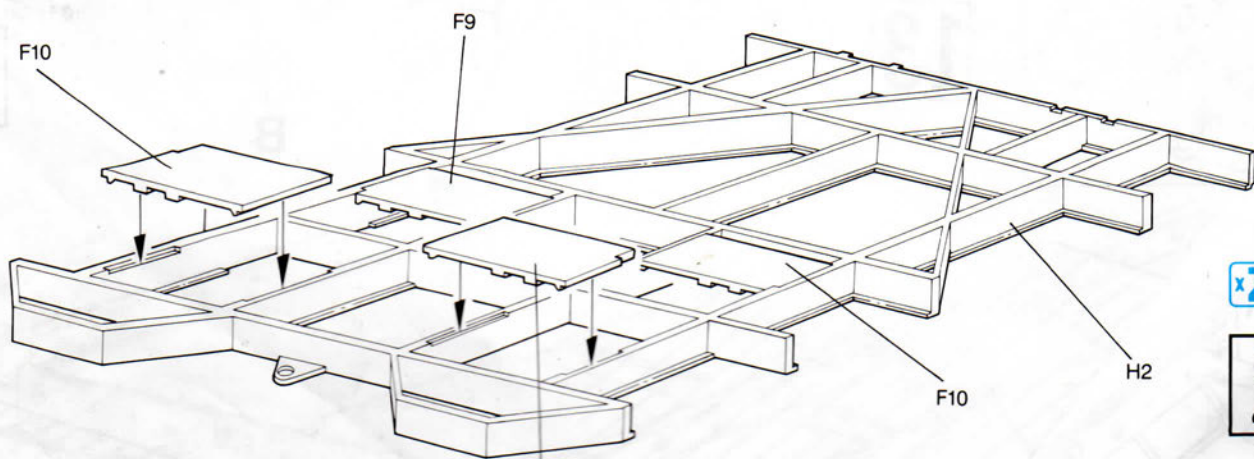
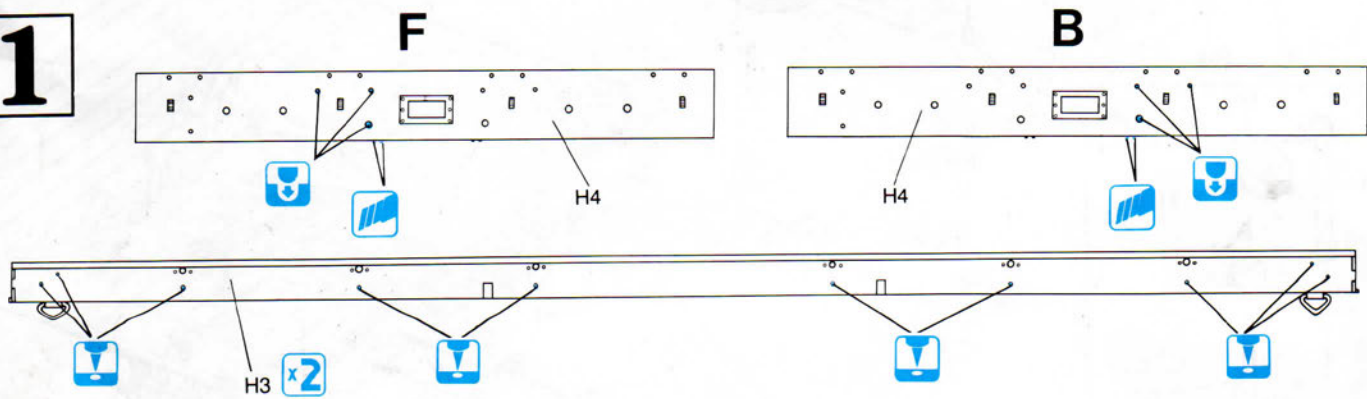

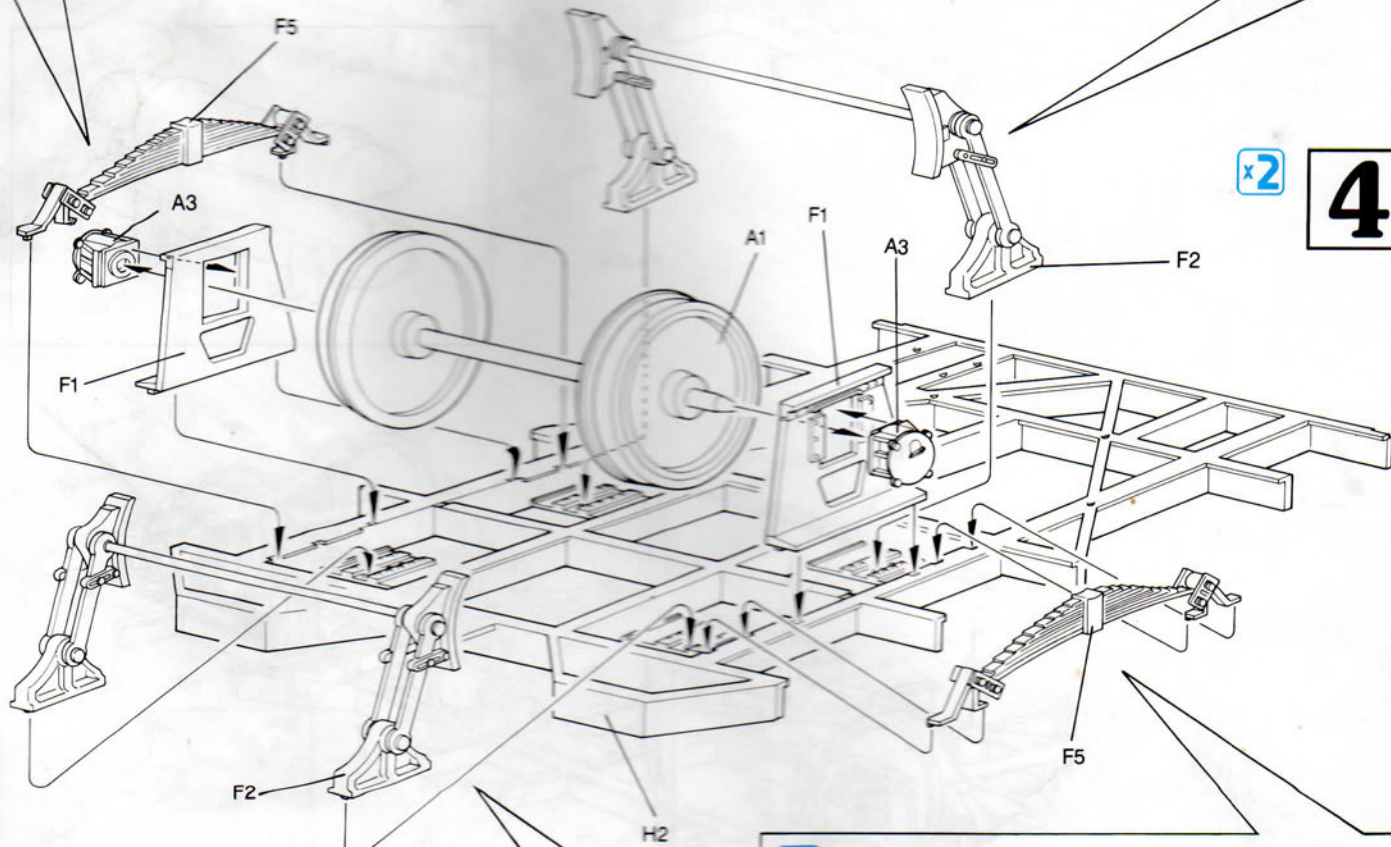
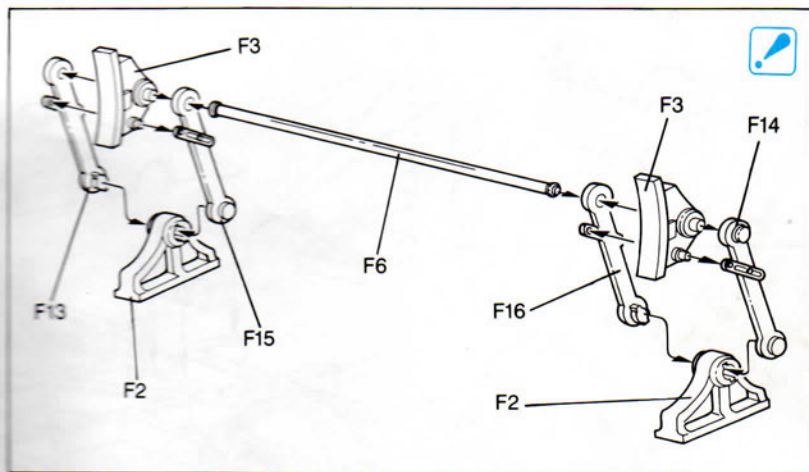
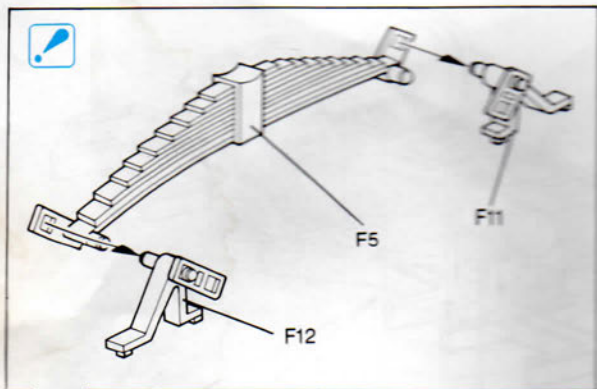
**1****3**

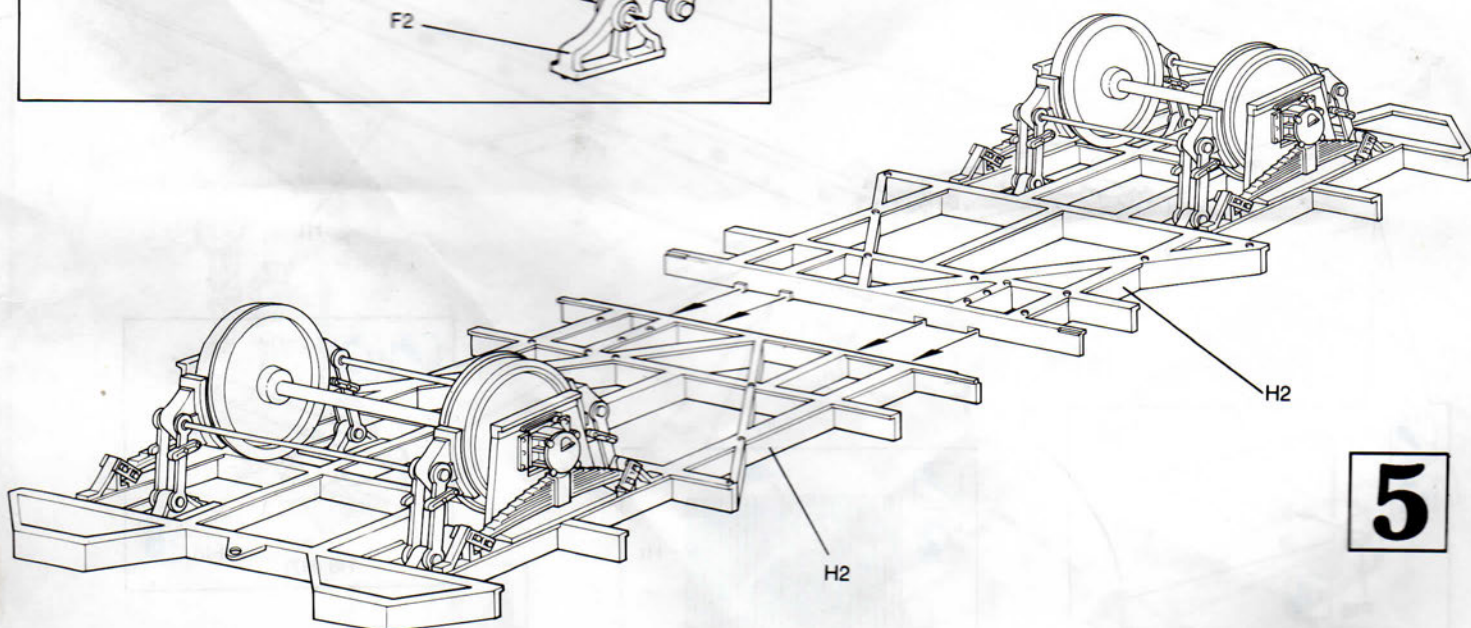
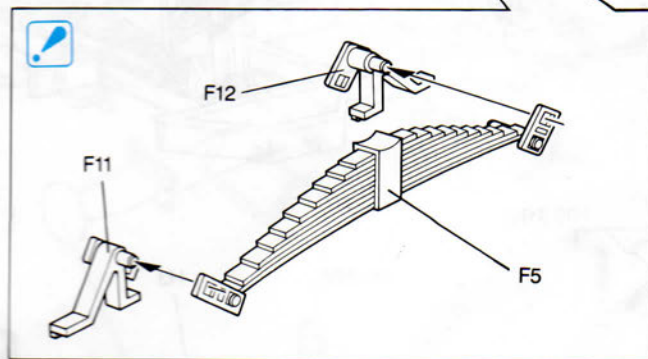
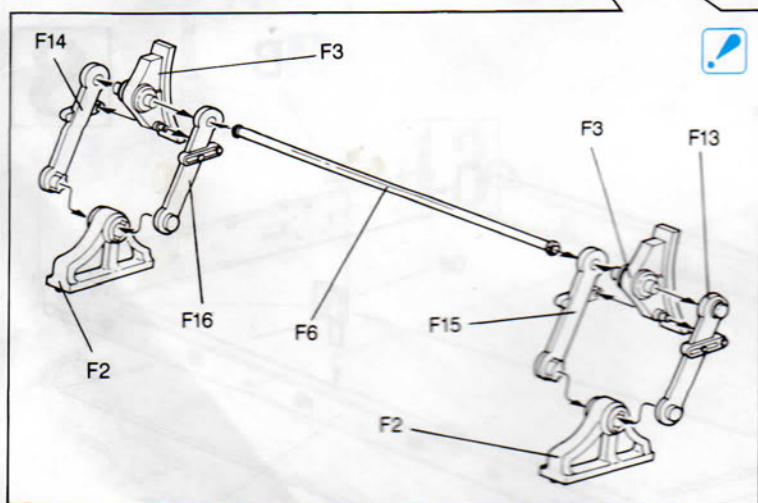
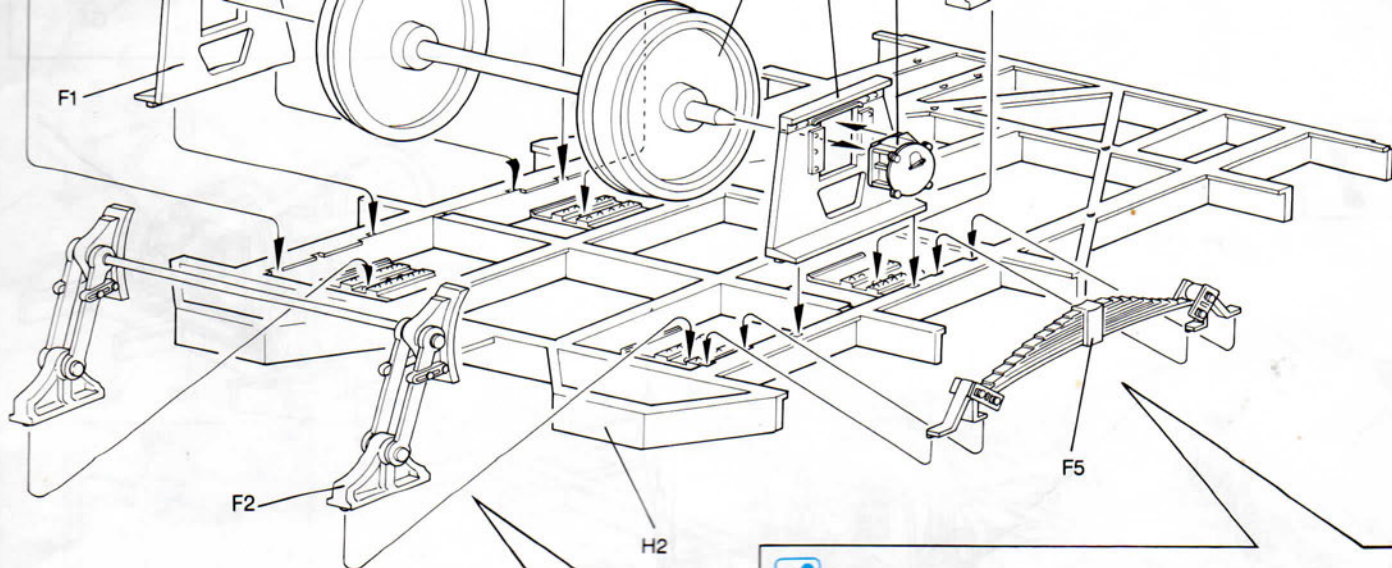



**5**

6

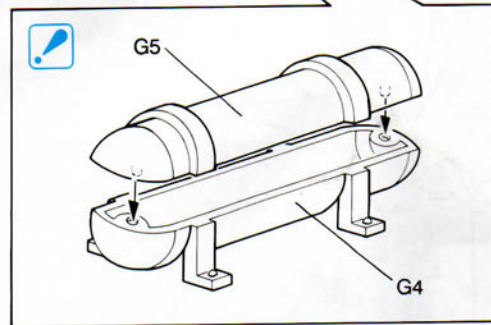
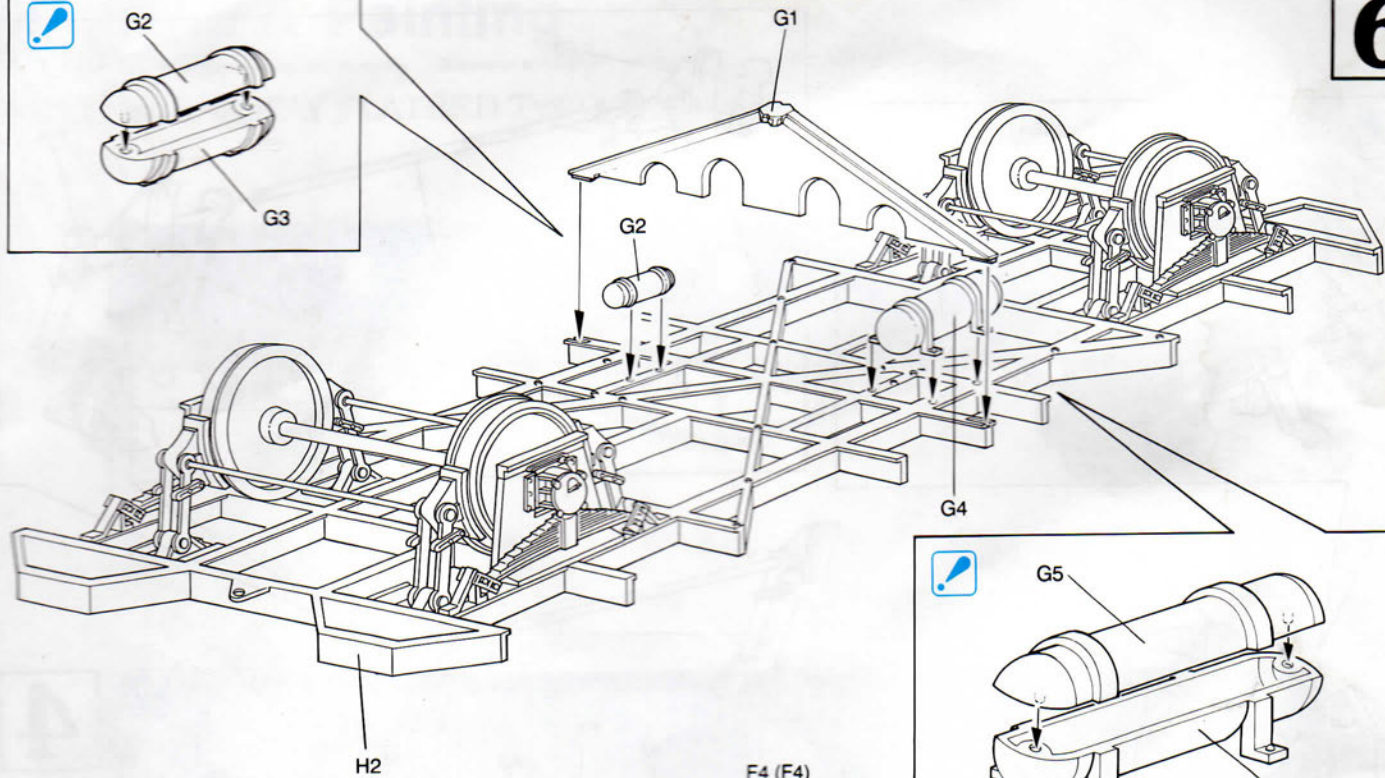
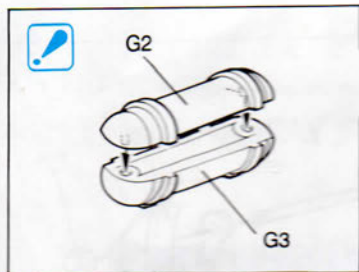

F4 (F4)

**7**

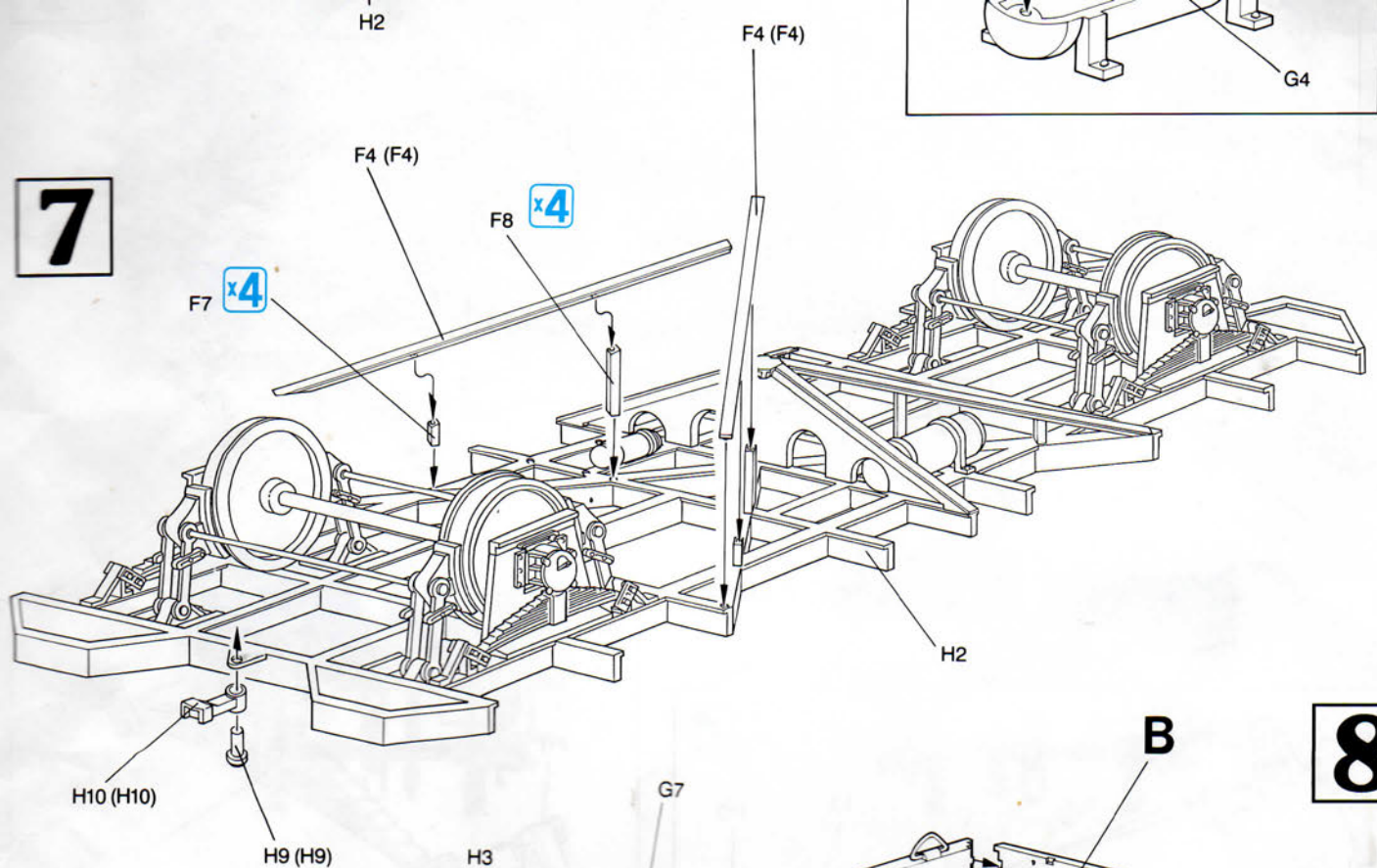

**8**

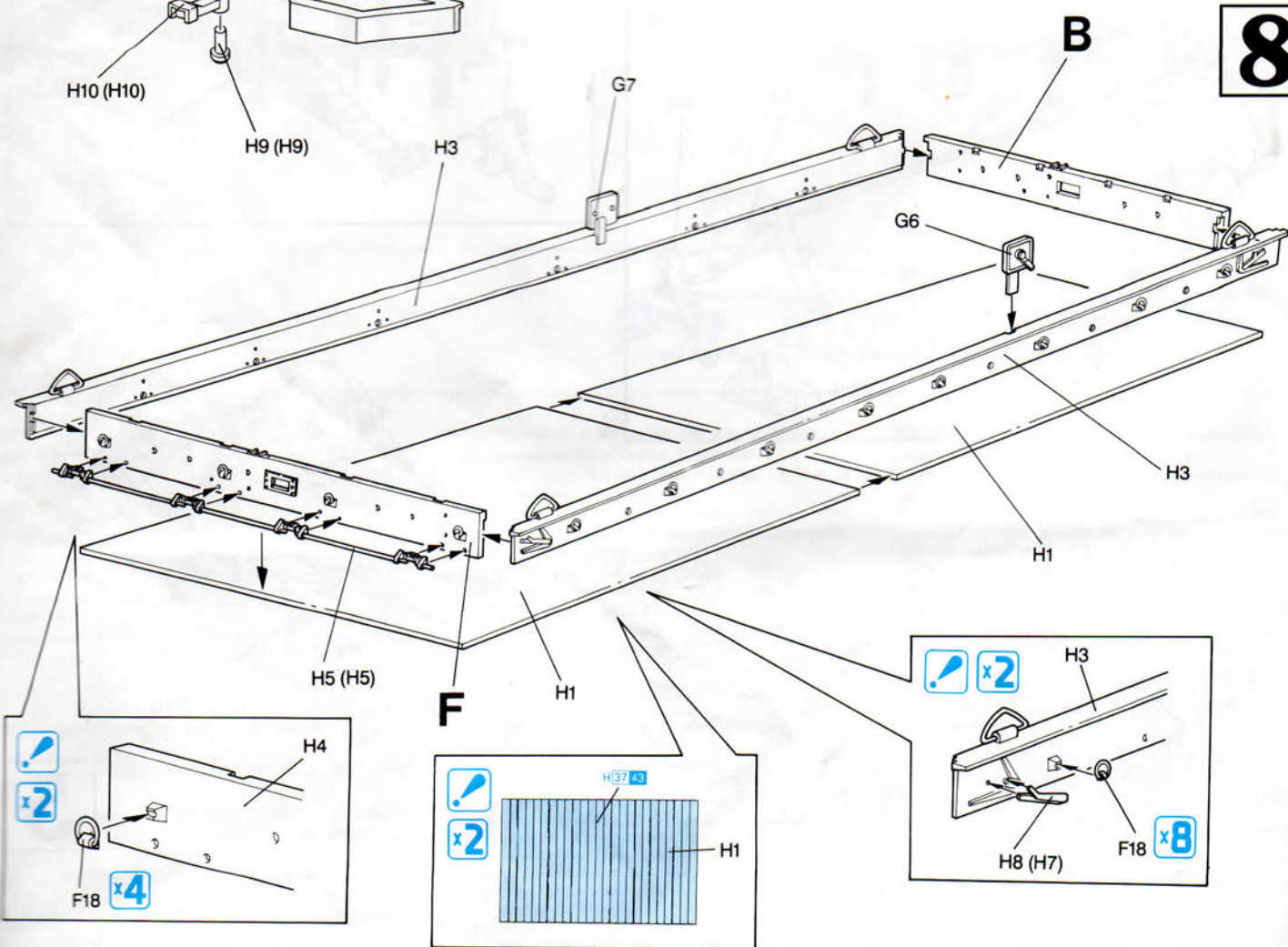



**9**

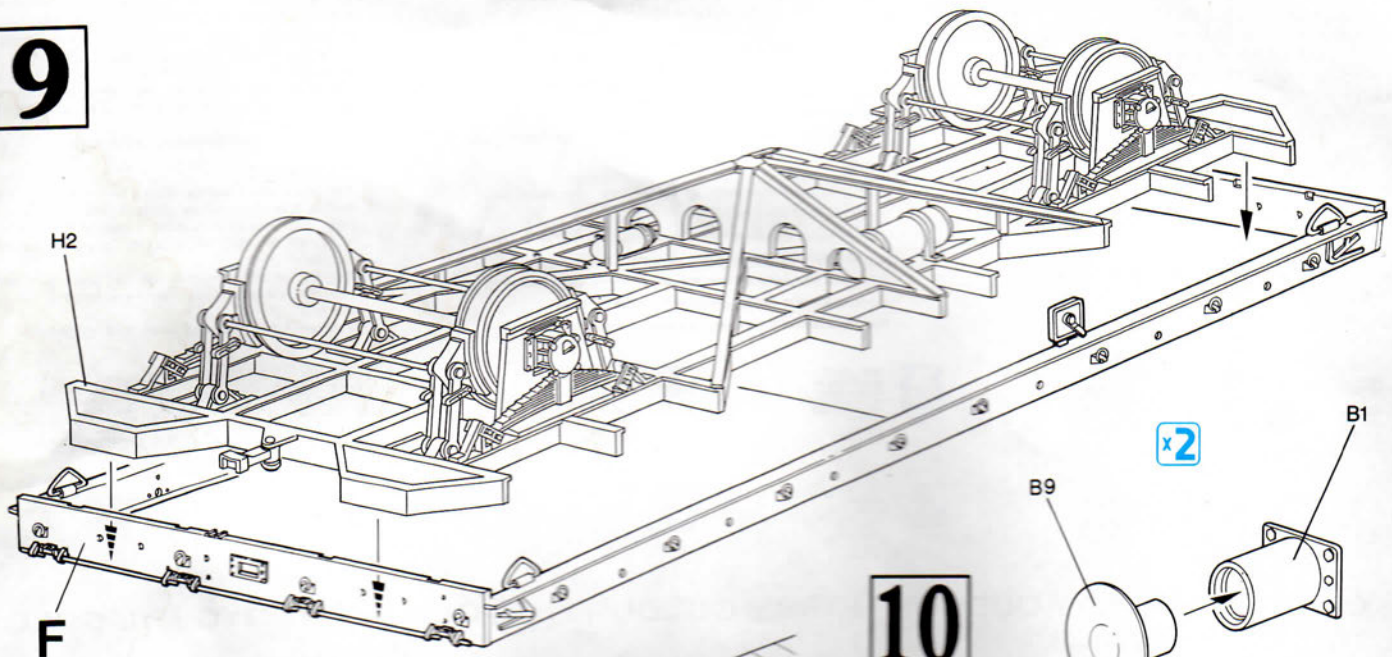

**10**

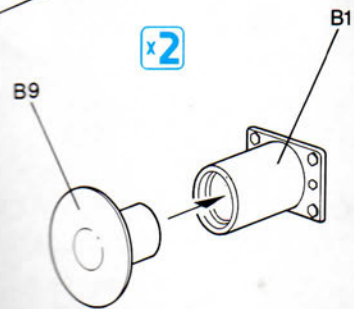

**11**

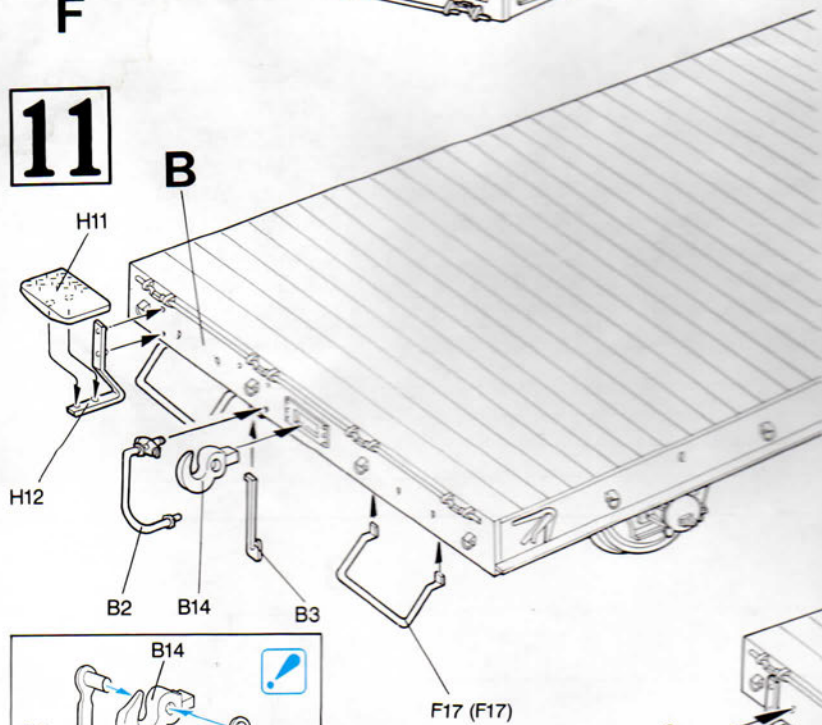

**x2**

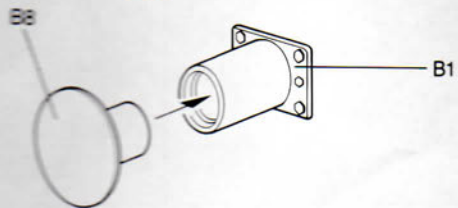

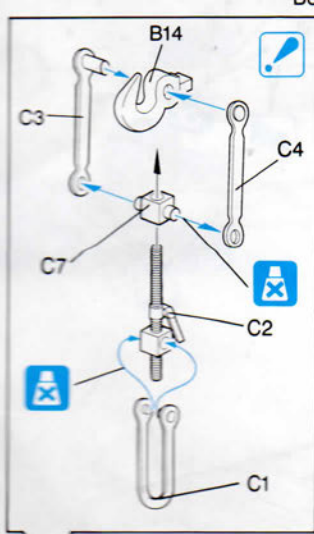

**13**

F17 (F17)

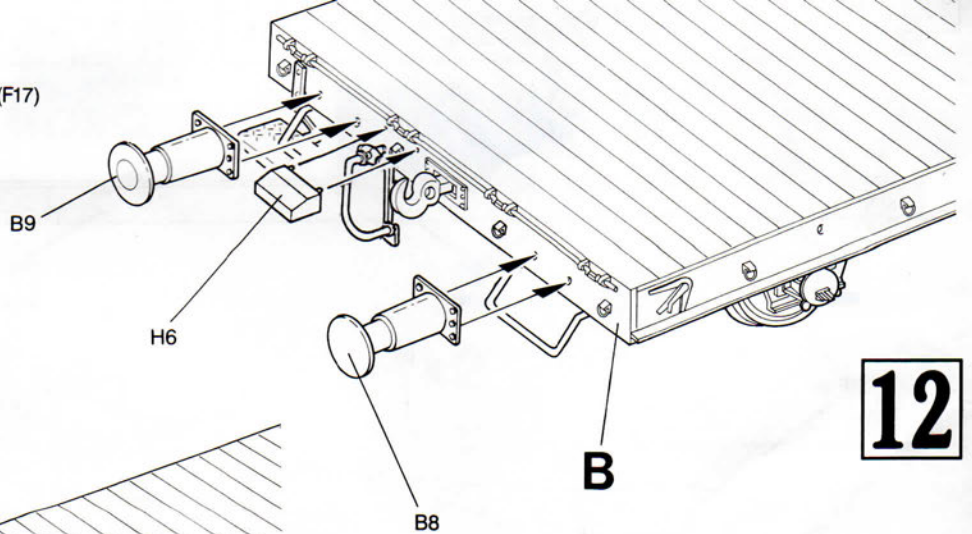

**12**

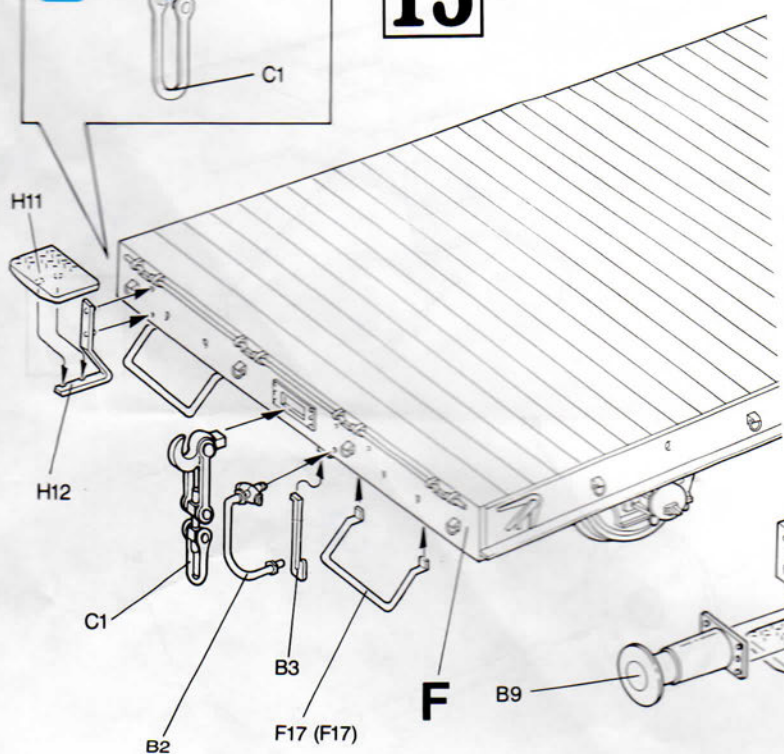

**14**

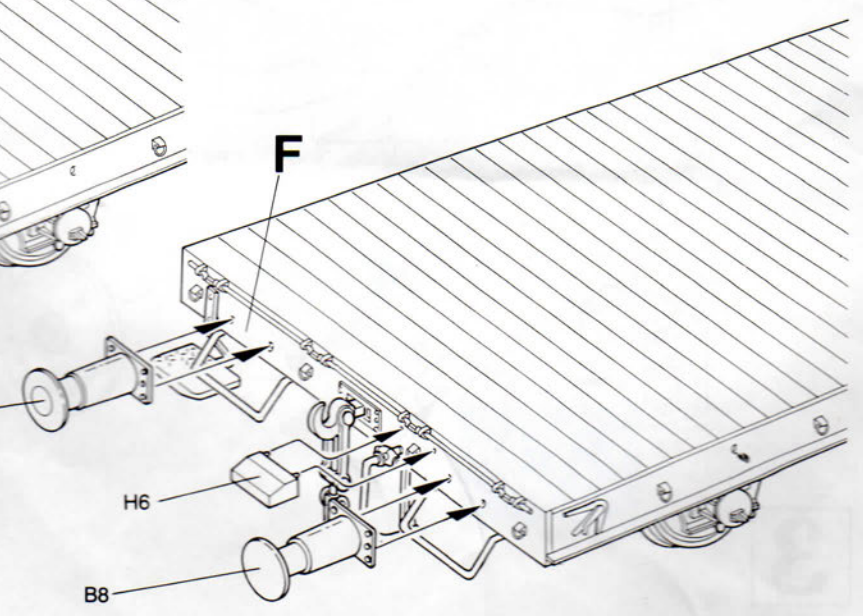

15 x2

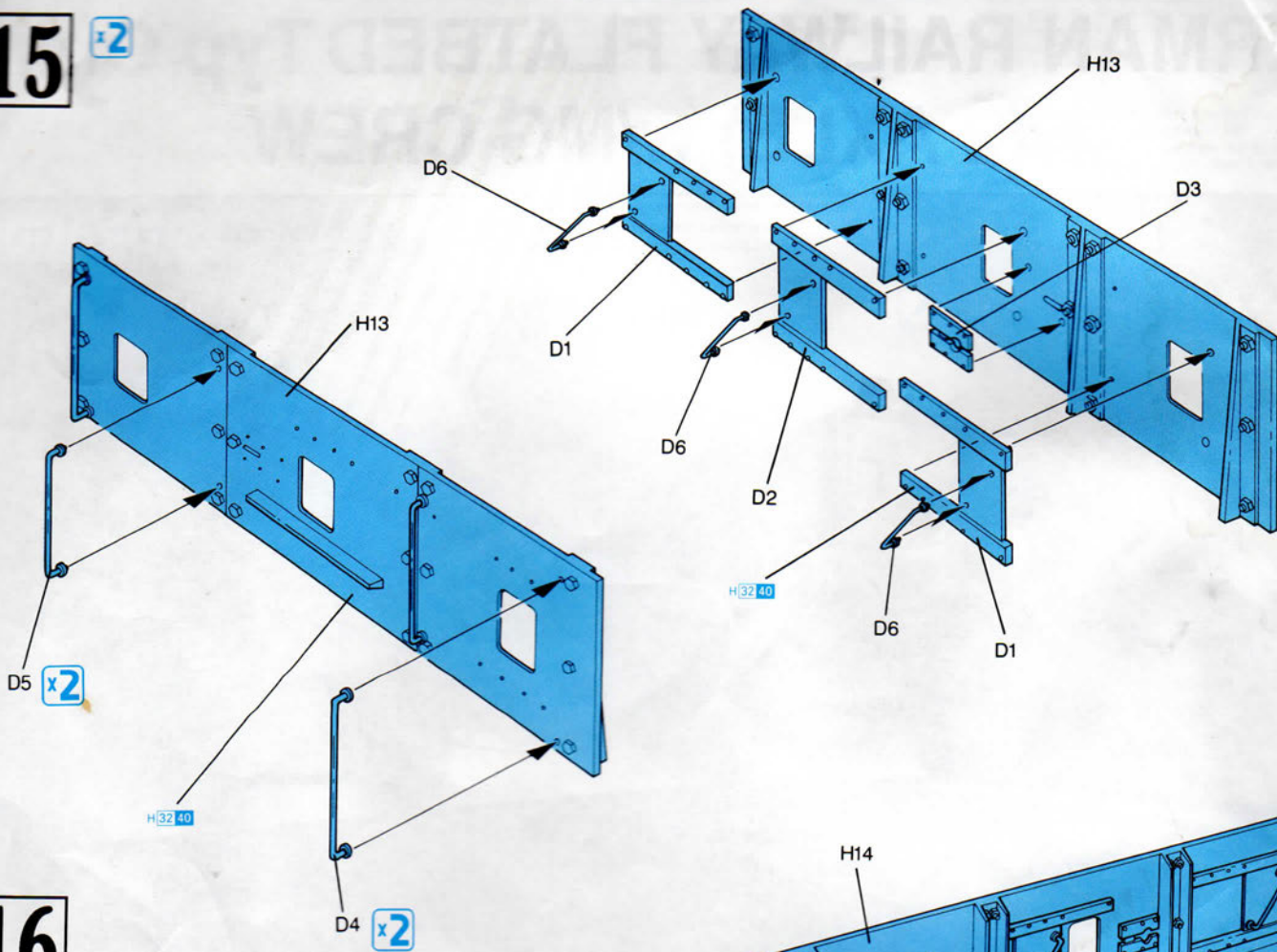

16 x2

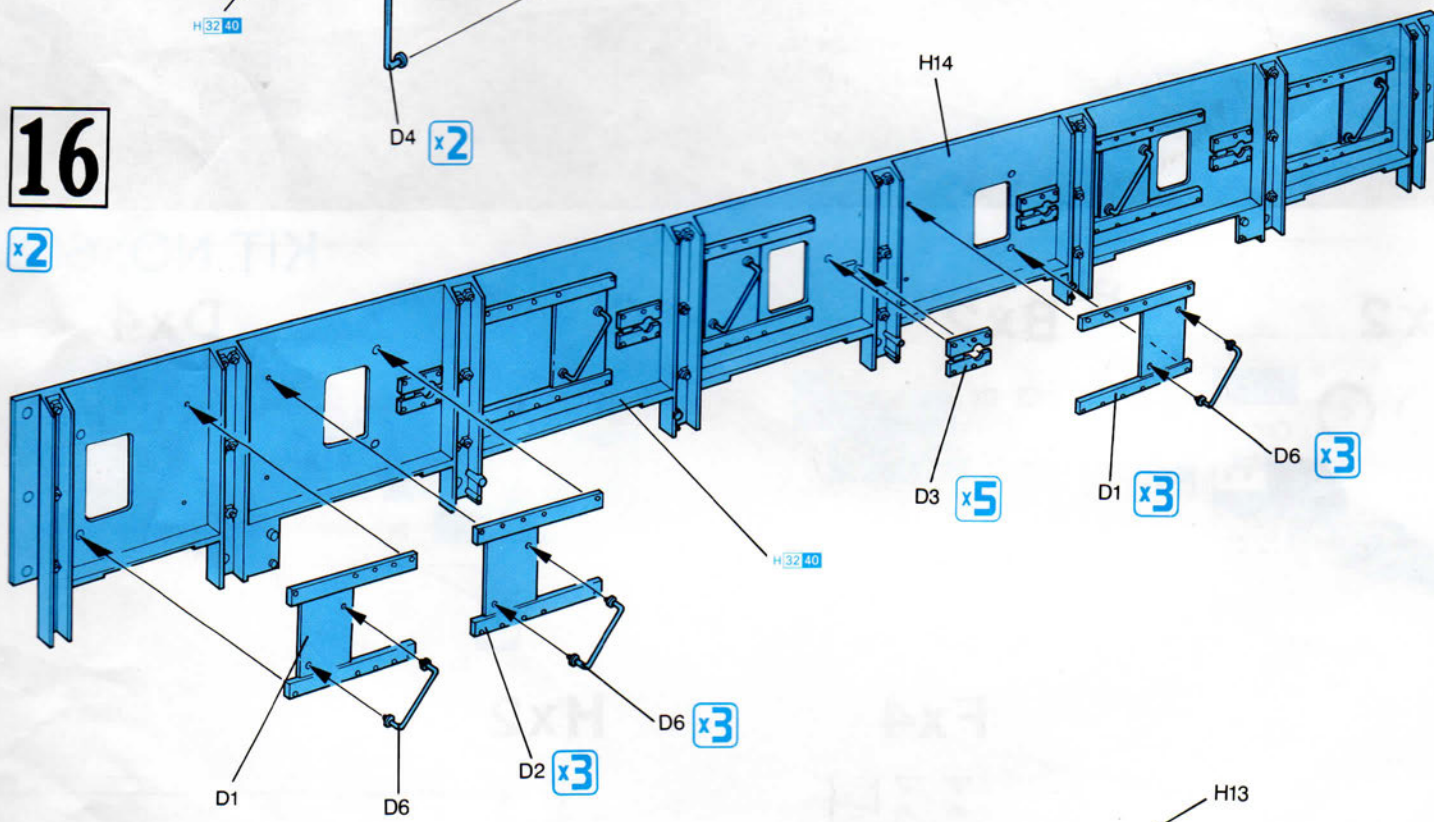

D1

D6

D2 **x3**

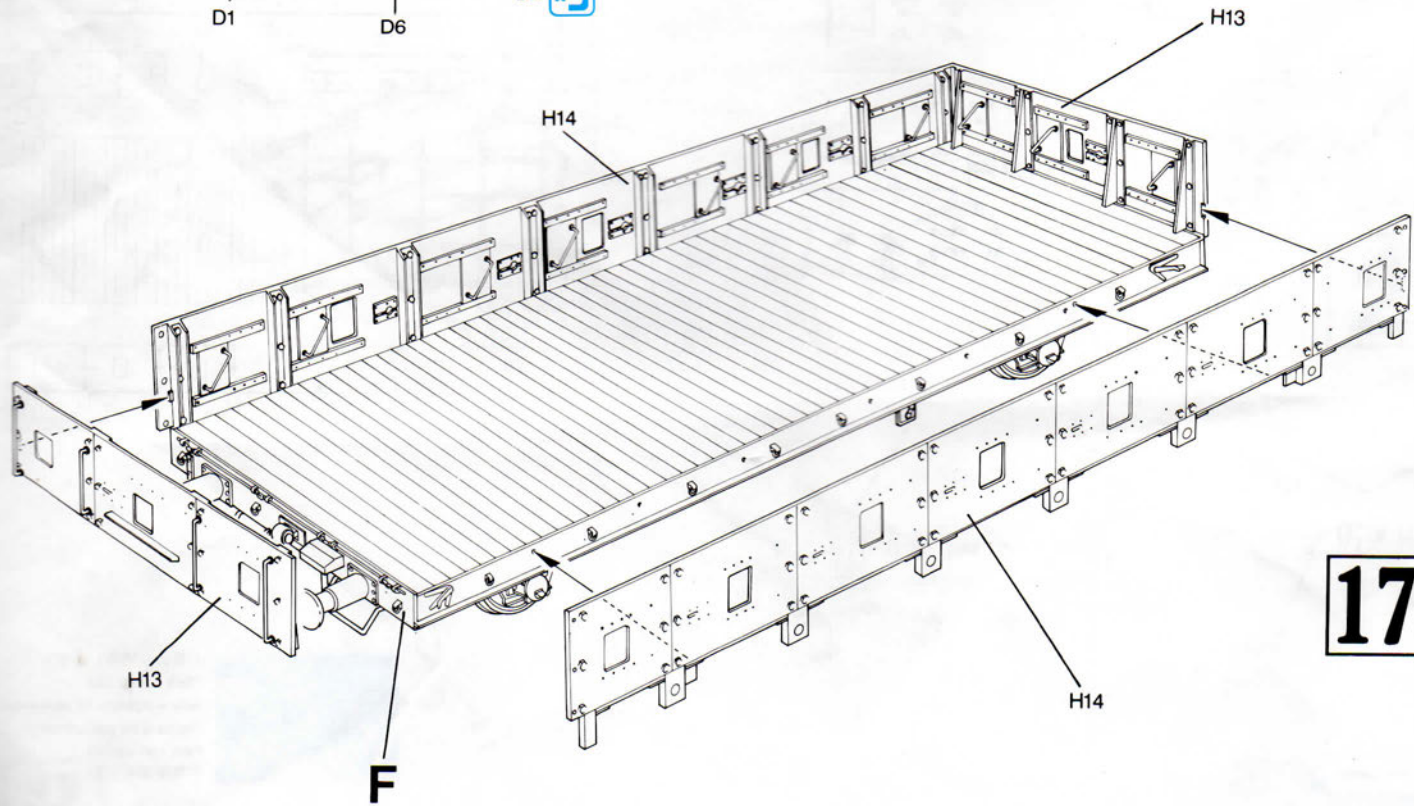

**17**

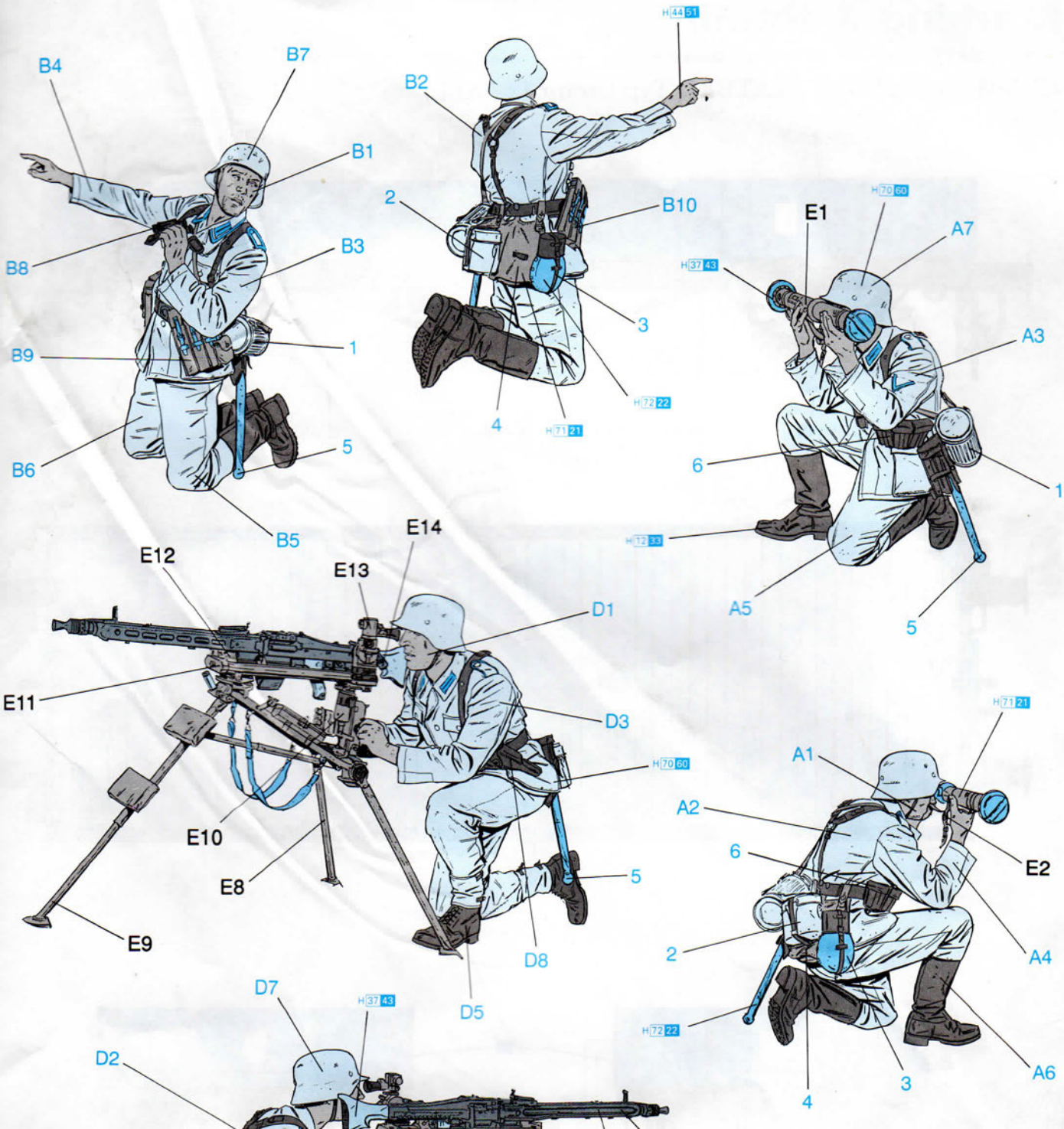

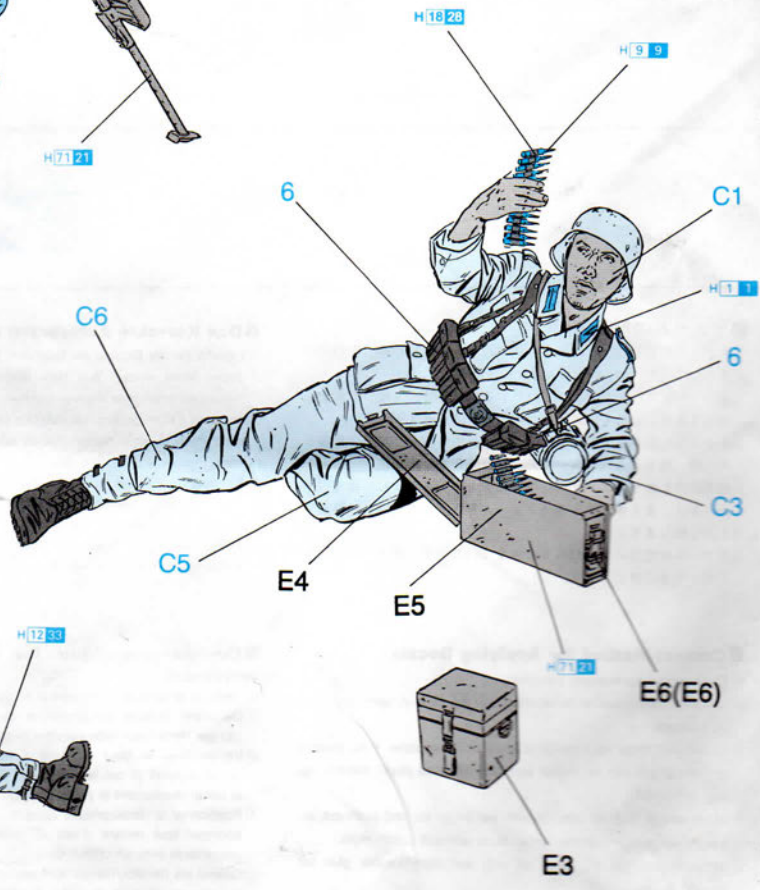
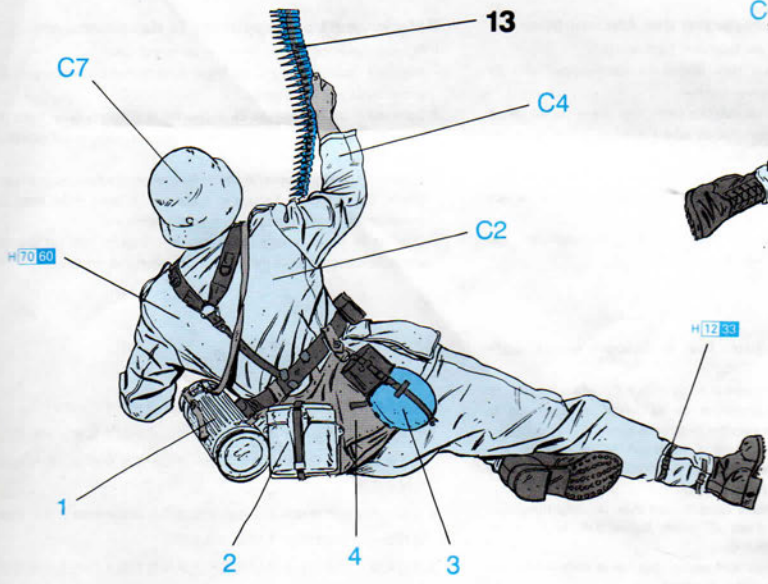
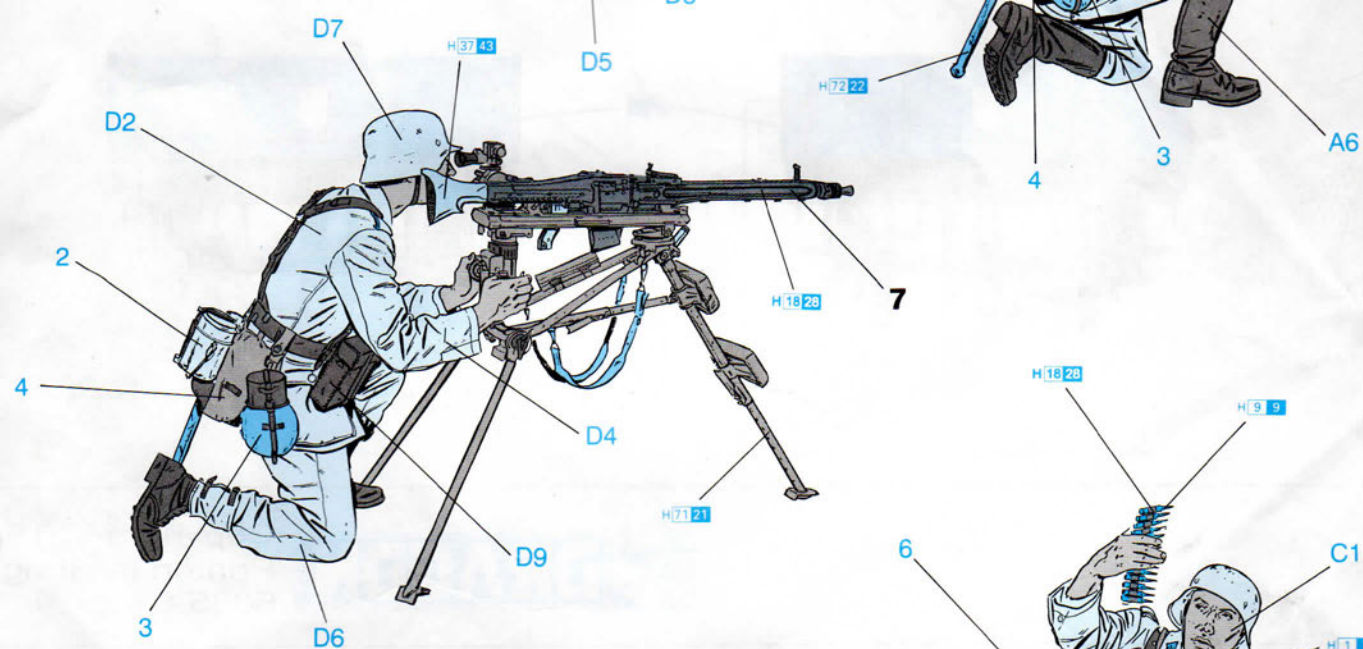

# Marking & Painting

マーキング及び塗装図    Markierungen und Bemalung    Decoration et Peinture    Marchio & Pittura    標貼及着色指示

## GERMAN RAILWAY FLATBED Typ Ommr (2 AXLE)

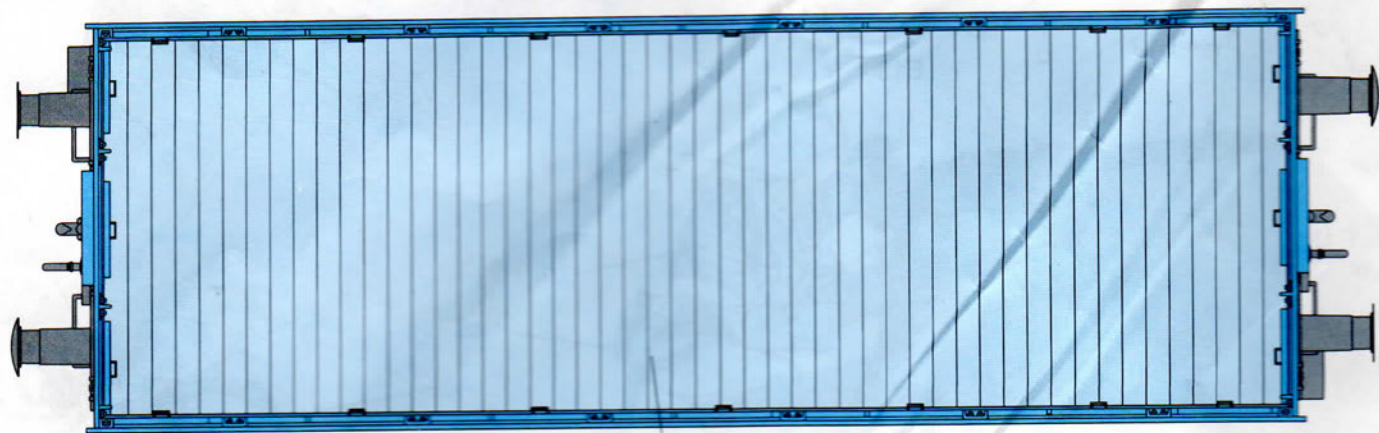
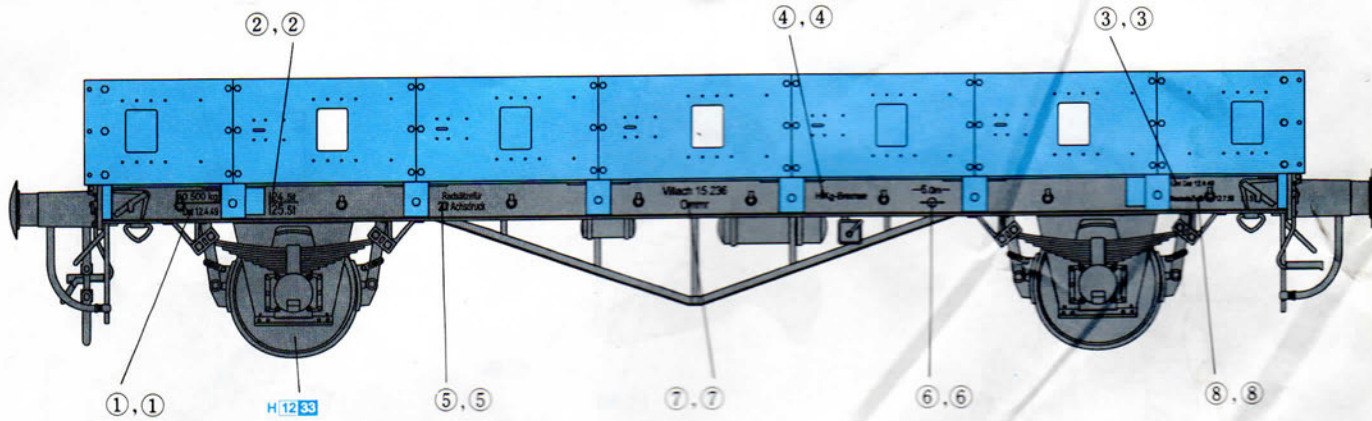

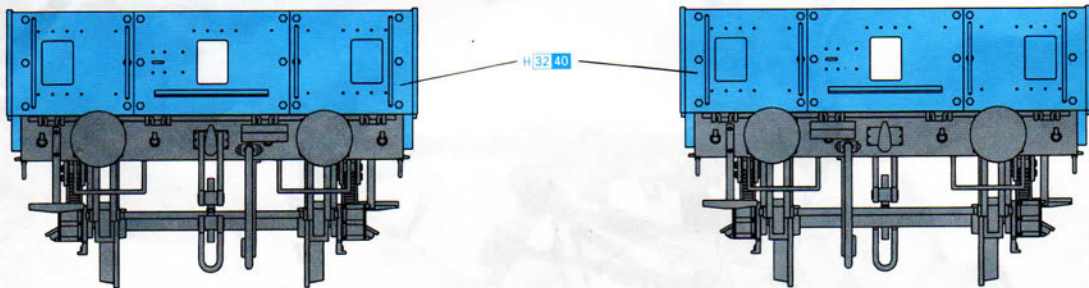

**DRAGON**

Copyright © 1998  
Printed in Hong Kong  
6085-01

#### ■ デカールの貼り方

- 1 デカールを貼るところのほこりや汚れを、ぬらした布できれいにふきとってください。
- 2 貼りたいデカールを台紙ごとハサミで切りとり、1枚ずつ水またはぬるま湯に台紙を下にして20秒くらい浮かべます。
- 3 水から出したらタオルの上のせ、指先でデカールが動くか確かめた後、貼るところにおいて静かに台紙をずします。
- 4 指先に少し水をつけて正確な位置にデカールを動かした後、やわらかく、よく水を吸う布でデカールを押さえて内側の水分や気泡を押し出します。
- 5 デカールが完全に乾いたら少し水をつけた布で、デカールのまわりのノリをふきとります。

#### ■ Correct Method for Applying Decals

- 1 Clean model surface with wet cloth.
- 2 Cut each design out of decal sheet and dip them in warm water for 20 seconds.
- 3 Check with finger tip if design is loose on base paper. If so, place it on proper position on model and slide off base paper leaving design on model.
- 4 Move design to exact position with wet finger tip, and push out excess water and air bubbles under decal with soft cotton cloth.
- 5 When decals get dry, wipe off with wet cloth excess glue left around decals.

#### ■ Das Korrekte Aufbringen der Abziehbilder

- 1 Oberfläche des Modells mit feuchtem Tuch reinigen.
- 2 Jedes Motiv einzeln aus dem Bogen ausschneiden und 20 Sekunden in warmes Wasser tauchen.
- 3 Mit dem Finger prüfen, ob sich das Motiv vom Trägerpapier gelöst hat. Wenn ja, so schieben Sie es vom Papier weg auf seine genaue Position auf dem Modell.
- 4 Korrigieren Sie die exakte Lage mit nasser Fingerspitze und drücken Sie Wasserblasen unter dem Abziehbild mit einem weichen Baumwolltuch weg.
- 5 Entfernen Sie beim Antrocknen der Abziehbilder die Klebmittelränder mit einem feuchten Tuch.

#### ■ Comment appliquer les décalcomanies correctement

- 1 Nettoyer la surface du modèle avec un chiffon humide.
- 2 Découper chaque décalcomanie de sa feuille de papier et la plonger dans l'eau tiède pendant vingt secondes.
- 3 Vérifier avec le bout du doigt si le dessin se détache de son papier-support. Si oui, le positionner à l'endroit choisi sur le modèle et retirer doucement le papier-support.
- 4 Positionner la décalcomanie correctement avec un doigt humide et éponger tout restant d'eau et toutes bulles d'air sous la décalcomanie avec un chiffon doux.
- 5 Quand les décalcomanies sont sèche, détacher le colle autour des décalcomanies avec un chiffon humide.

#### ■ Modo esatt per applicare le decalcomanie

- 1 Pulire la superficie del modello con un panno umido.
- 2 Ritagliare ciascun disegno dal foglio decalcomanie e immergerli in acqua calda per 20 secondi.
- 3 Controllare col polpastrello se il disegno è allentato sulla base di carta. In questo caso, applicarlo nella esatta posizione sul modello facendolo scivolare dalla base di carta.
- 4 Spostare il disegno nella esatta posizione mediante il polpastrello umido, quindi togliere l'acqua in eccesso e le bolle d'aria sotto la decalcomania mediante un panno soffice di cotone.
- 5 Quando la decalcomanie sono asciutte, togliere con un panno umido l'eccesso di colla intorno alla decalcomania stessa.

#### ■ 貼上水印標貼的正確方法：

- 1 用濕布抹乾淨模型表面。
- 2 按照各標貼的形狀從標貼紙上切出，浸到溫水之中約20秒。
- 3 用指尖試行觸摸以確定標貼是否已脫離底紙，如果屬實，則把標貼連底紙放到模型表面的適當位置上，小心地將底紙移去，把標貼留在模型表面。
- 4 以濕水的指尖把標貼移到正確的位置上，再用柔軟的綿質布料把標貼輕壓，以擠出標貼底下的氣泡和水份。
- 5 標貼乾後，用濕布輕拭標貼及其附近的模型表面，以洗去可能殘留在標貼附近的多餘膠水，確保效果完美。