

X

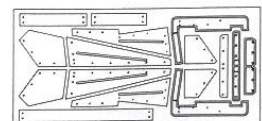

Y





## History | 历史介绍

## Crusader Mk.II

The Crusader was one of the major British cruiser tanks of the early WWII and perhaps the most important British tank of the North African campaign, the Crusader's mobility made it a favorite plaything of British tankers. The Crusader cruiser tank began development in 1939 with the development code A15 and was built jointly by several companies under the leadership of Nuffield. As it was improved on the basis of the Covenanters' tank, the development progressed quickly and it was successfully developed and started to equip the British army in 1940.

Unlike the early British cruiser tanks with Christie suspensions that used four road wheels, the Crusader had five road wheels to improve load distribution to carry 20 tons of hull weight instead of the previous 14 tons. The road wheels were 32-inch (810 mm) diameter pressed steel solid rubber wheels. Two separate steel plates were used between the suspension arms on each side of the hull, and the vehicle was fitted with a different engine and a different travel system than the Covenanters.

In the engine compartment is a conventional cooling system. Early designs even included a small manually rotating machine gun turret with a built-in Bertha machine gun in the left front driver's position, the radiator position of the "Covenanters". However, this small machine gun tower is difficult to manipulate, open the hatch will obstruct the operation of the main gun, usually in the battlefield will be removed.

The German army got this vehicle named Panzerkampfwagen MkV 746 (e), which was used in large numbers by the African army in North Africa because of its good mobility and speed to meet the situation in the desert battlefield.

十字军是第二次世界大战早期的主要英国巡洋坦克之一，也许也是北非战役中最重要的英国坦克，十字军的机动能力使得它成为英国坦克兵最喜欢的玩物。十字军巡洋坦克从1939年开始研制，研制代号为A15，由纳菲尔德公司领导下的几家公司联合制造。由于是在盟约者坦克的基础上改进的，研制进度很快，1940年便研制成功并开始装备英军。

不像英国早期的采用克里斯蒂悬挂的巡洋坦克采用4个负重轮，十字军有五个负重轮以改善载重分布来承受20吨的车体，而不是以前的14吨体重。负重轮为32英寸(810毫米)直径的压制钢实心橡胶轮。在车体两侧的悬挂臂之间分别采用了两块分离的钢板，并装上了与“盟约者”不同的发动机，不同的行走系统。

而发动机仓中则是一个传统的冷却散热系统。早期设计中甚至在车体左前方驾驶员位置，也就是“盟约者”的散热器位置，加装一个手动旋转的小型机枪塔，并内置一挺贝莎机枪。不过这个小型机枪塔难以操纵，打开舱门后会阻碍主炮运作，通常在上战场时会被拆除。

德军得到该车取名Panzerkampfwagen MkV 746 (e)。由于机动性好及速度快，满足沙漠战场的形势，所以在北非的非洲军大量使用该车。



1

! No glue on the outside 外側不塗膠

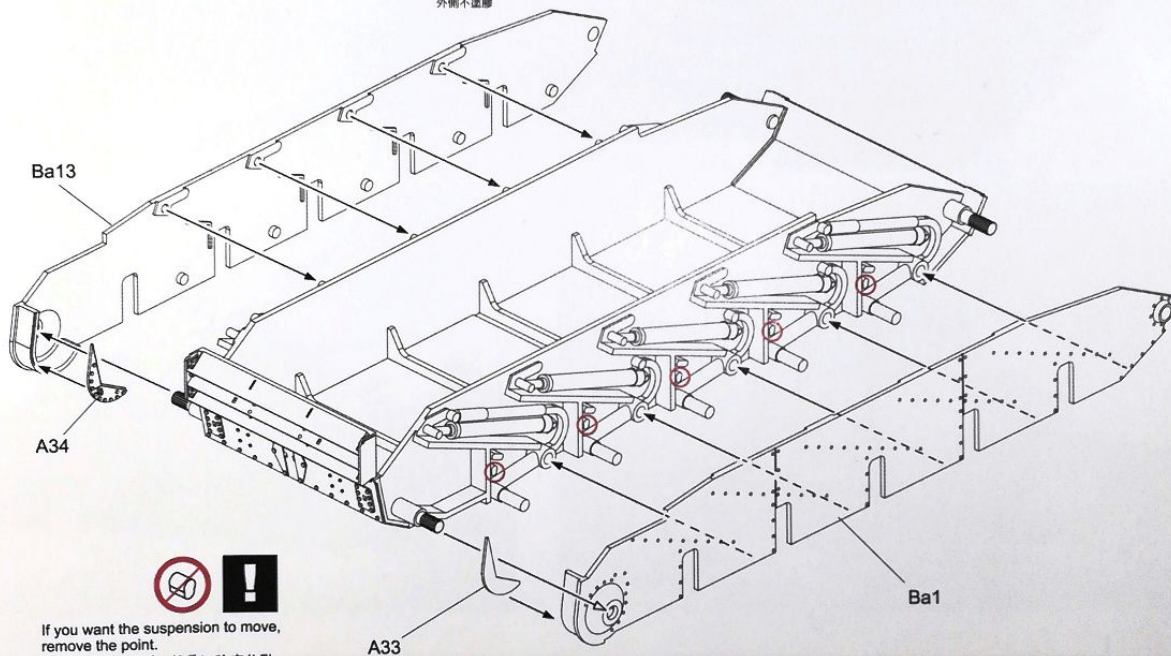
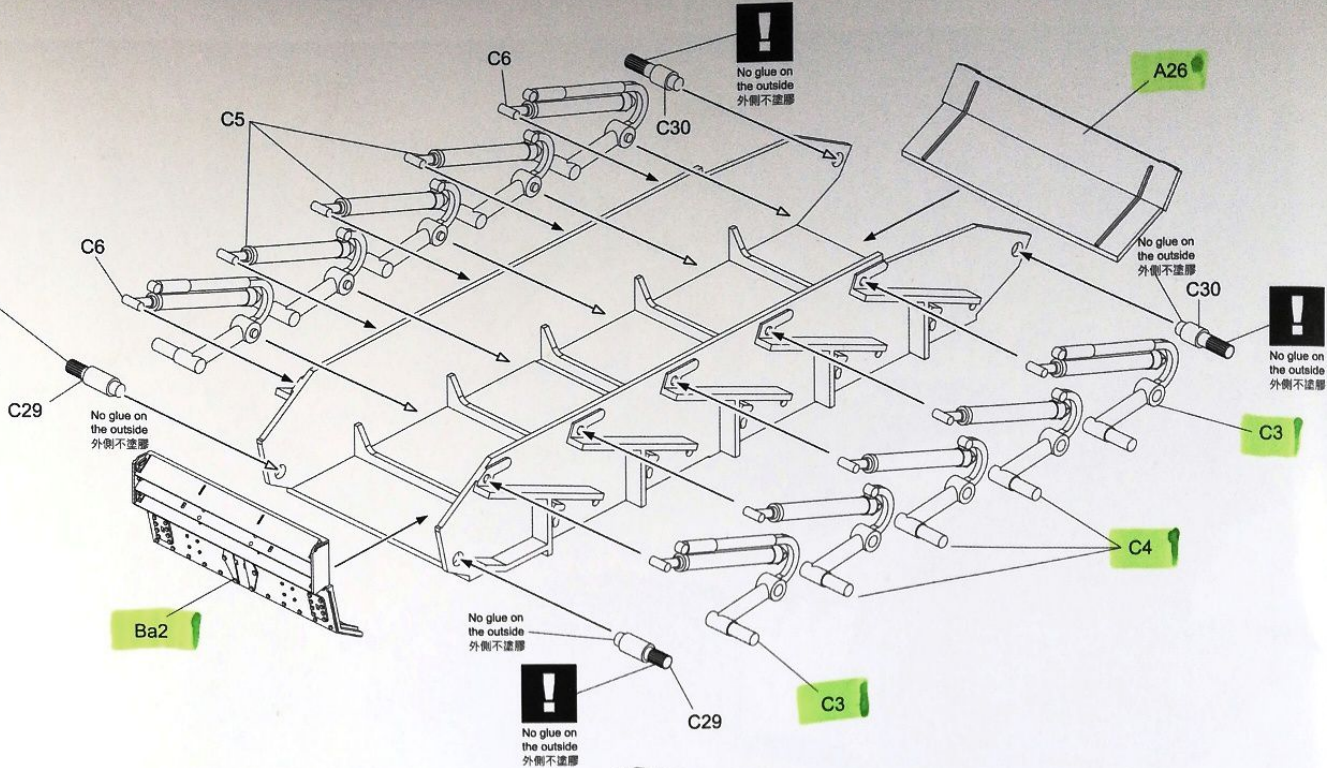

If you want the suspension to move, remove the point.  
假如需要懸掛可動, 就要切除定位點。

2

(A)

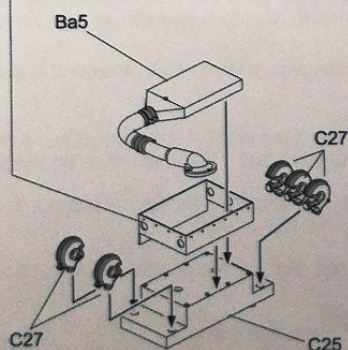
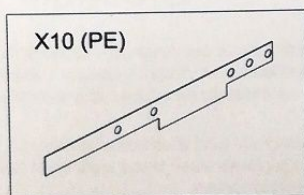

(B)

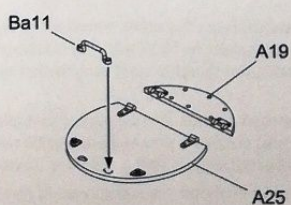

(D)

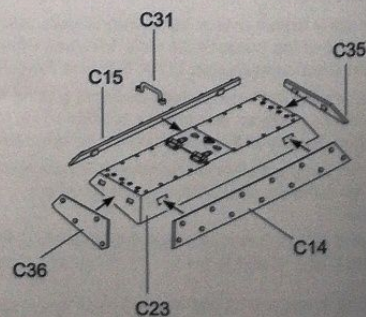

(C)

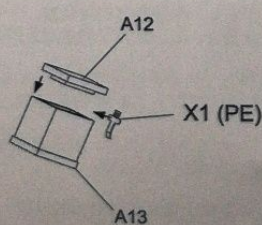



3

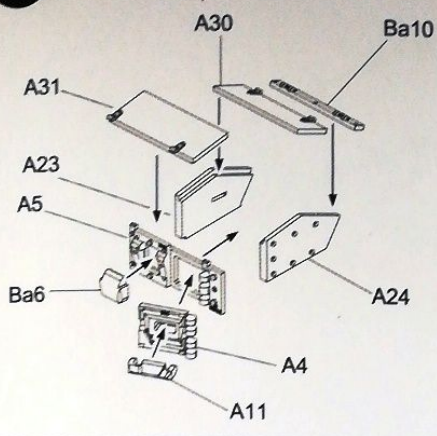

F

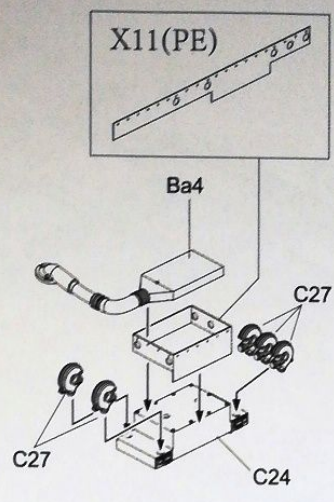

G

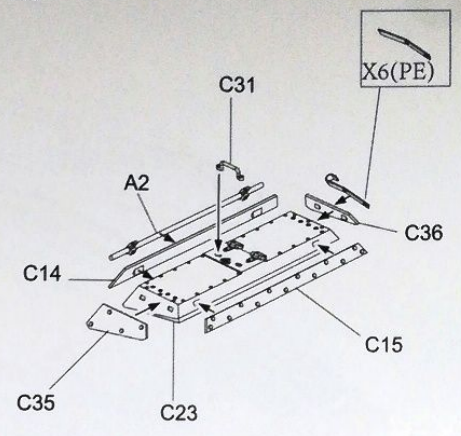

H

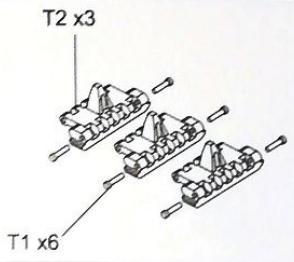

4

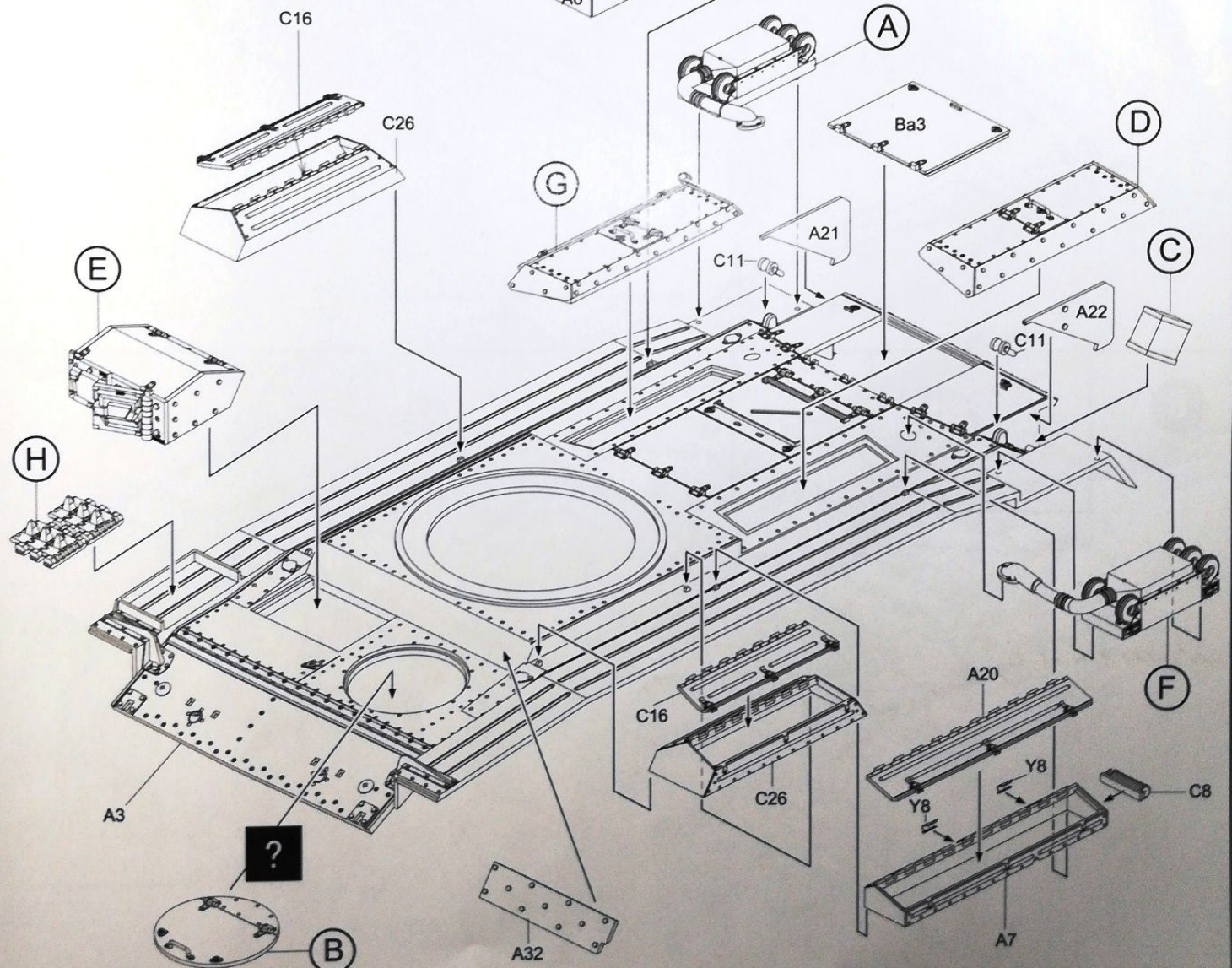
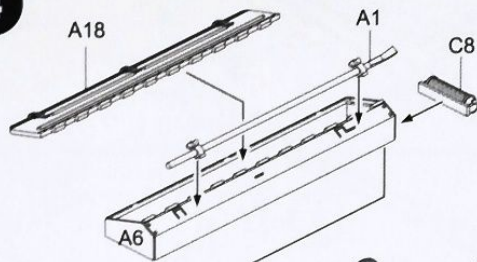

If you want to install a turret,  
you don't need to install this part  
如果安装小炮塔, 就不装这个零件



5

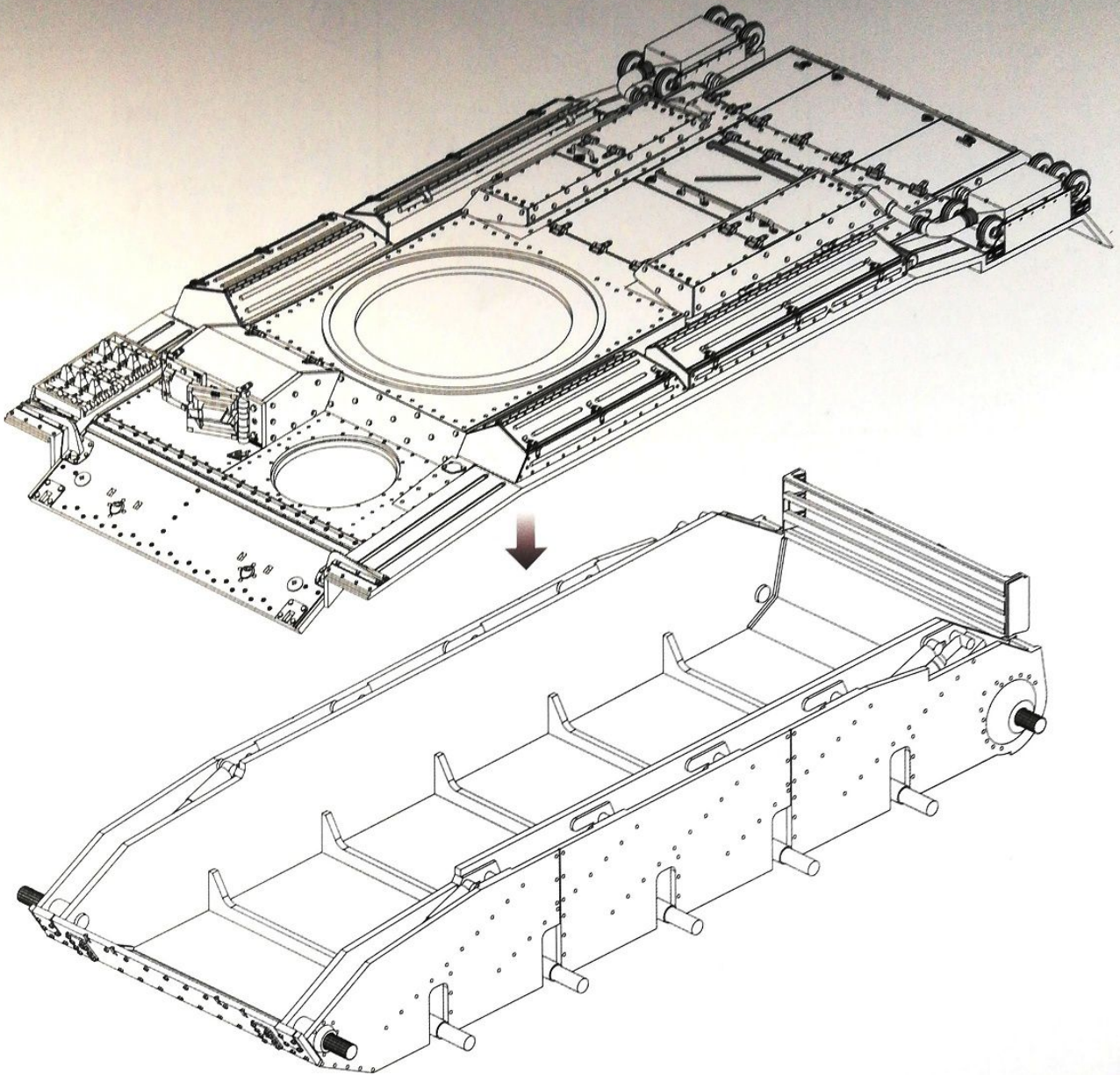

6

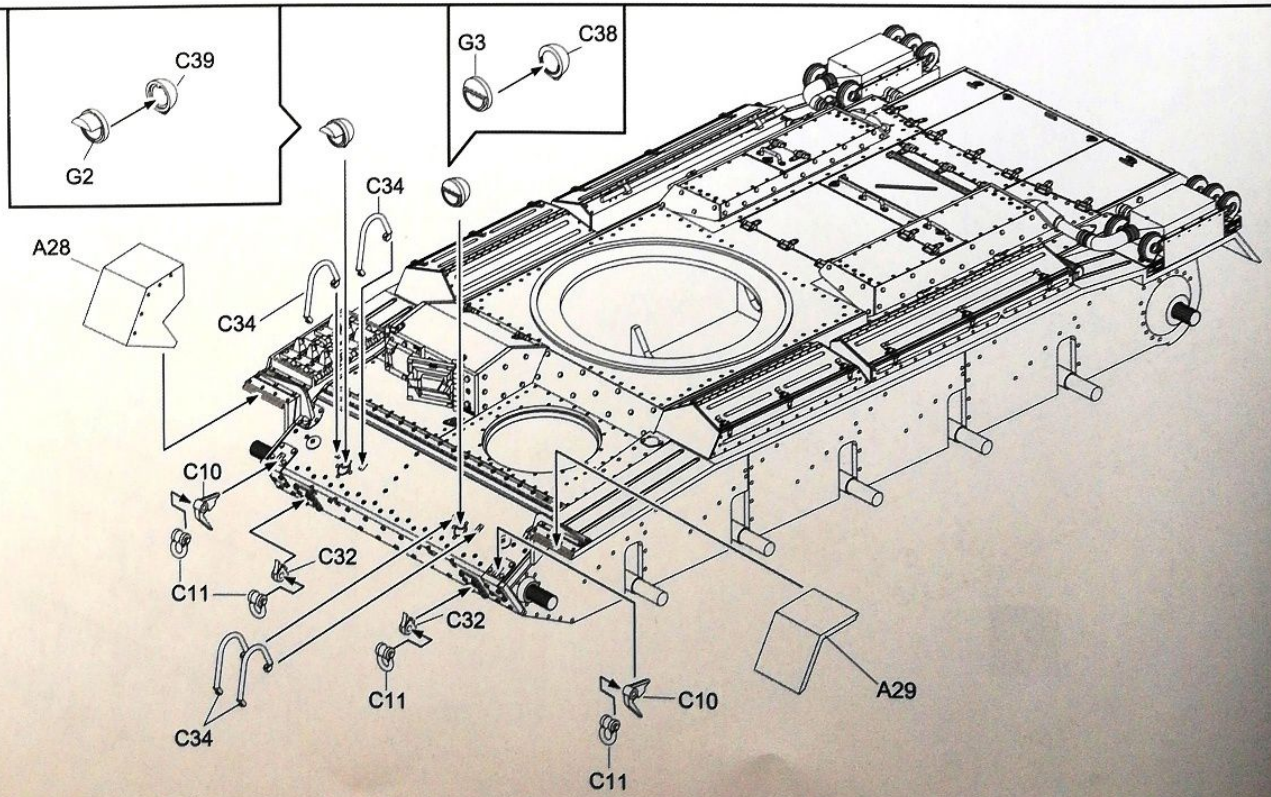



7

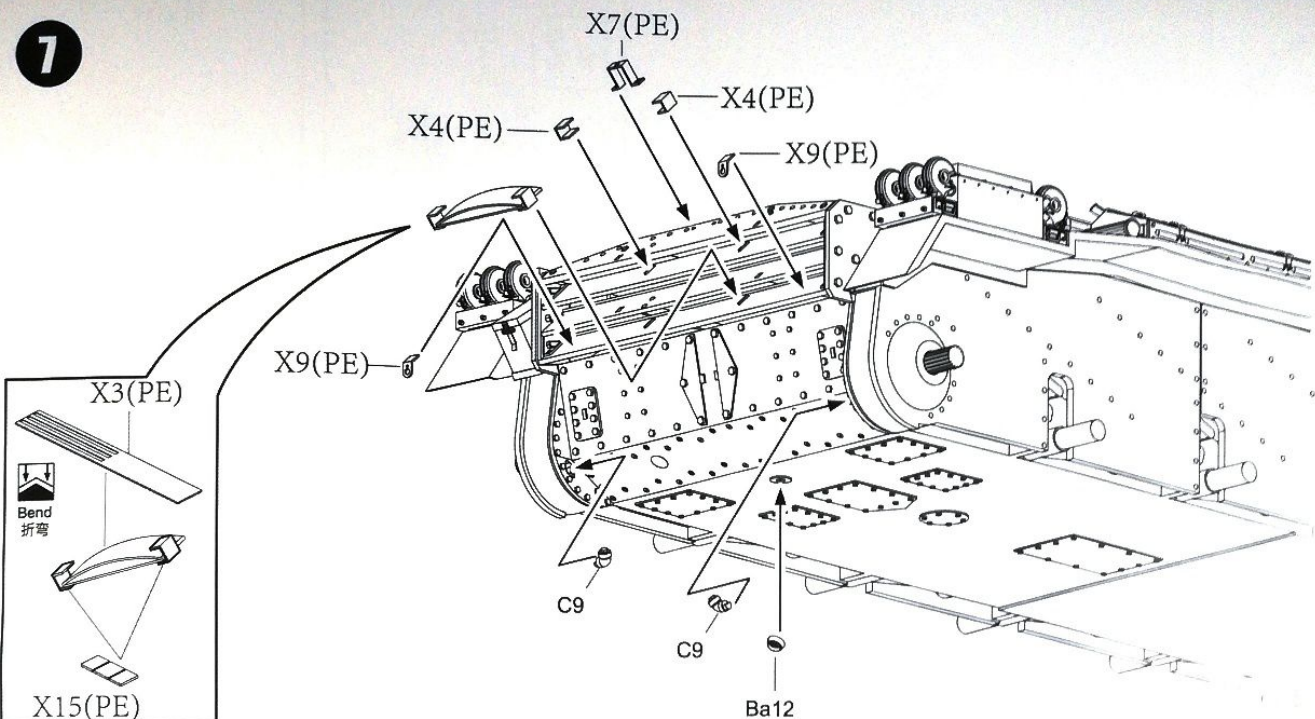

8

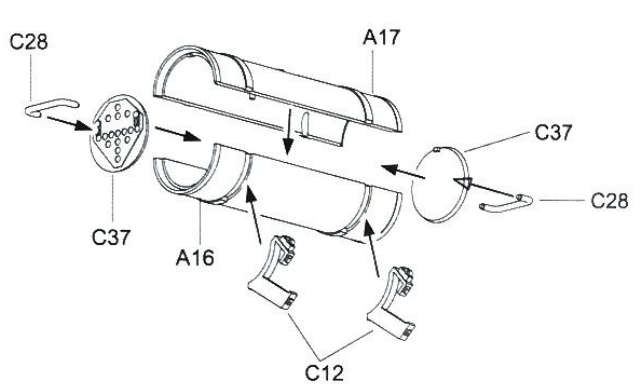

①

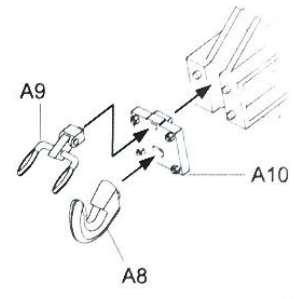

9

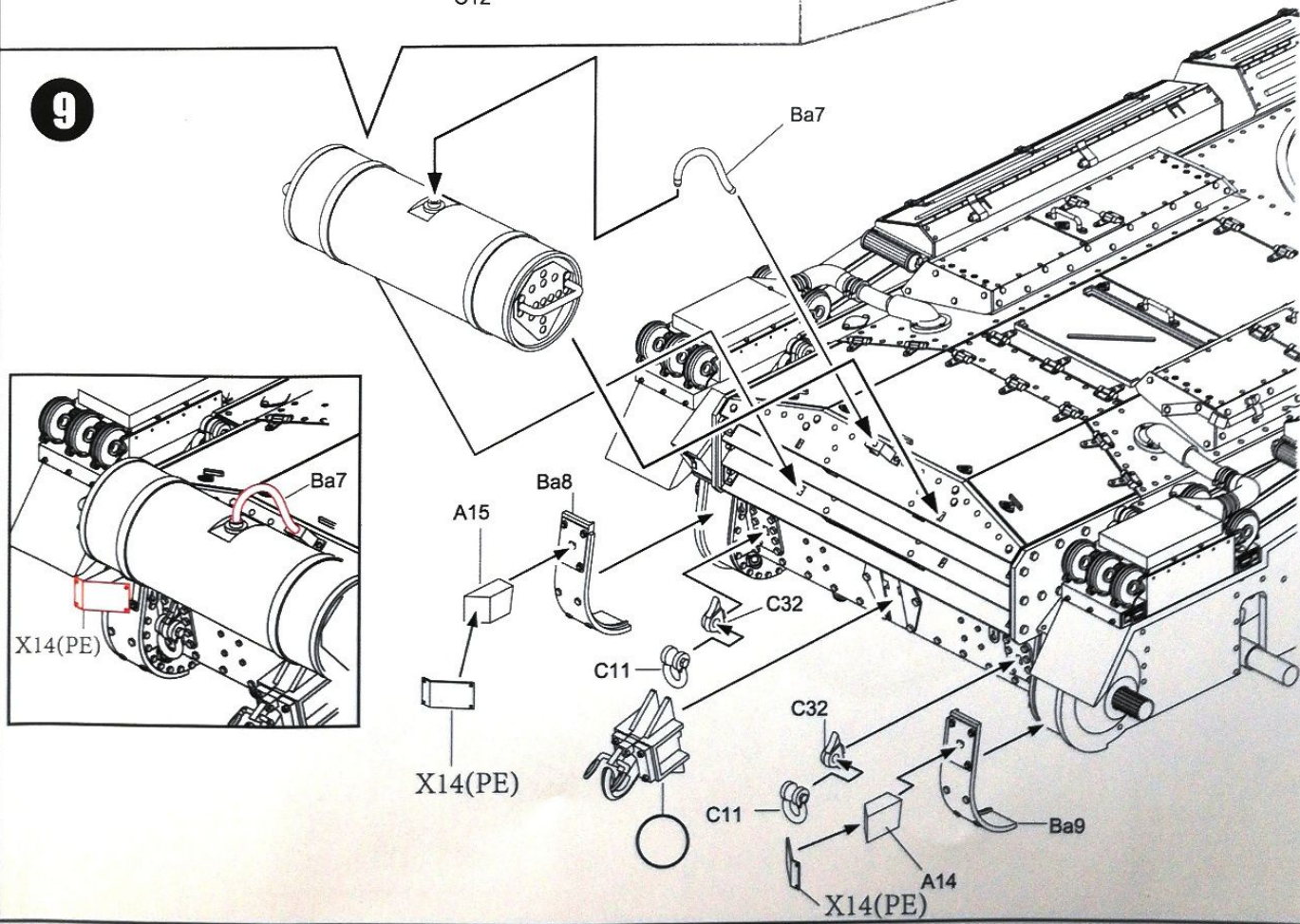



10

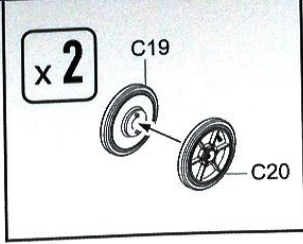
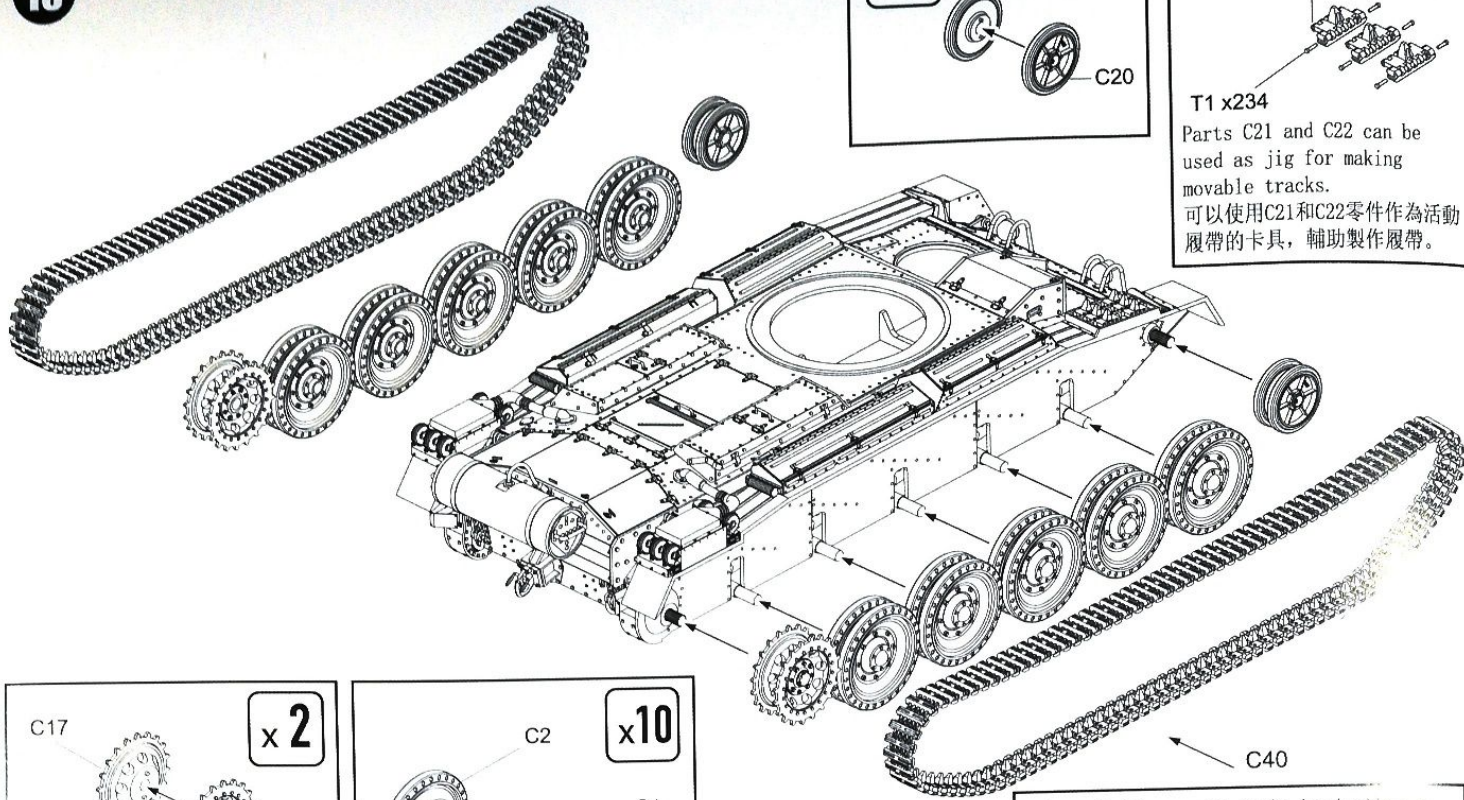

T2 x117

T1 x234

Parts C21 and C22 can be used as jig for making movable tracks.  
 可以使用C21和C22零件作為活動履帶的卡具，輔助製作履帶。

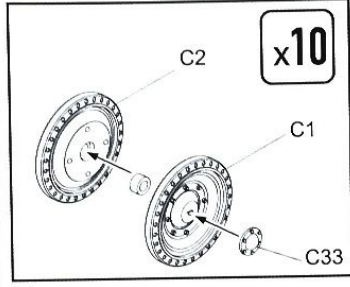
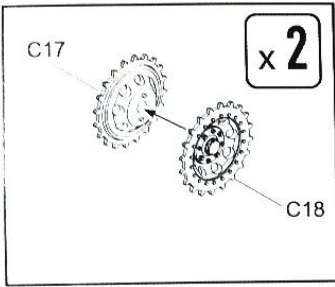

If you find the movable tracks too troublesome to assemble, you can also choose to use part C40 to save time.  
 如果你覺得活動履帶裝起來太麻煩，也可以選擇使用C40零件以節約時間。

11

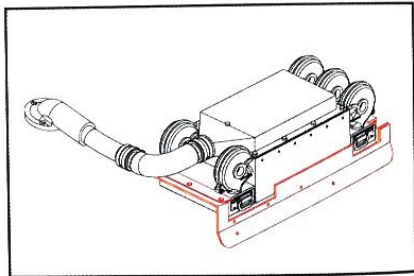
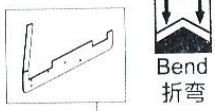
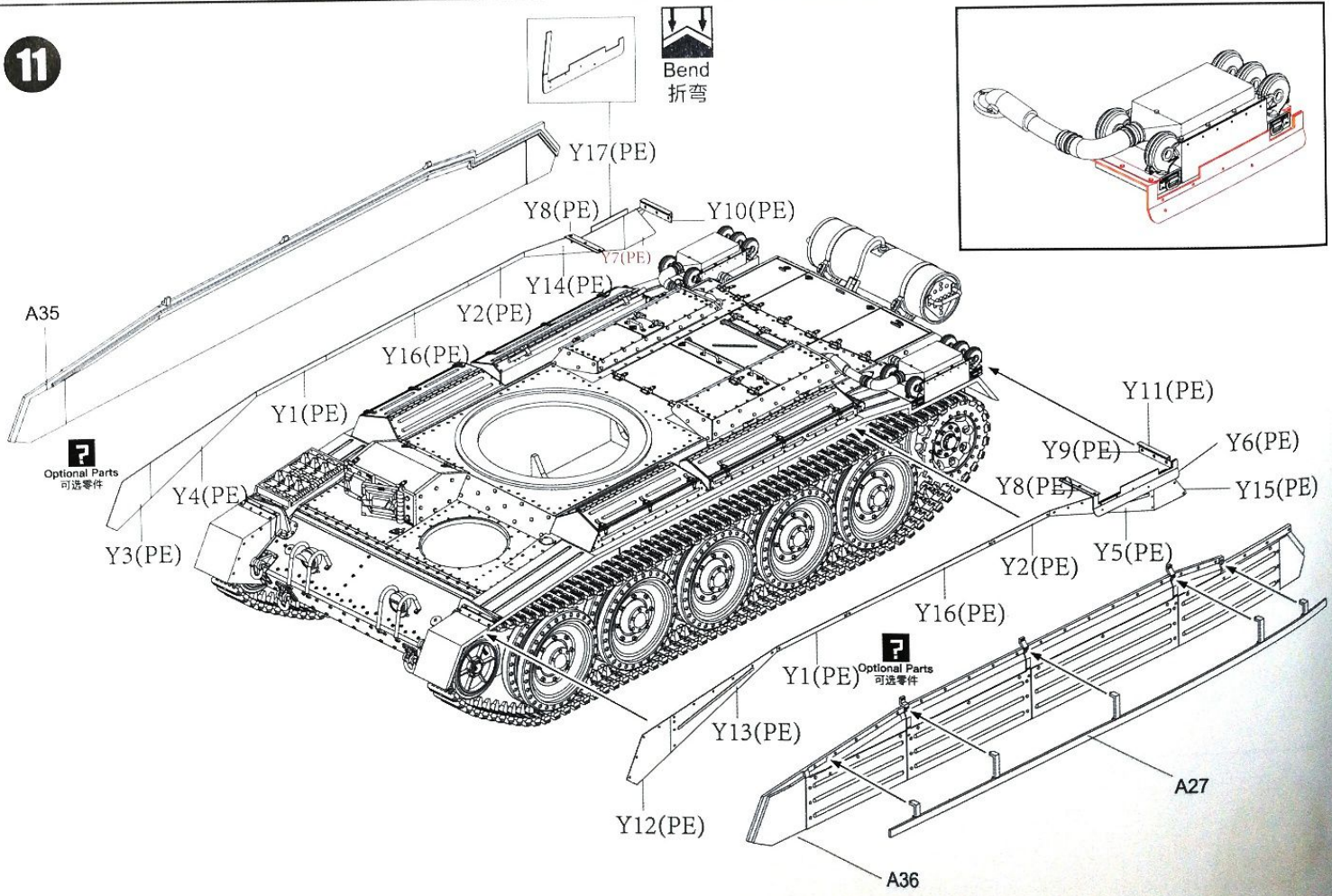

Optional Parts  
 可选零件

Optional Parts  
 可选零件



12

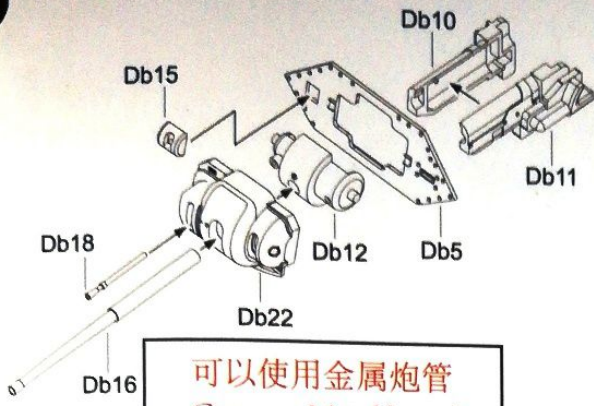

可以使用金属炮管  
Can use Metal barrel

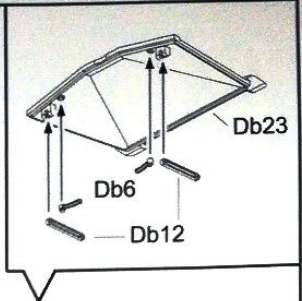

13

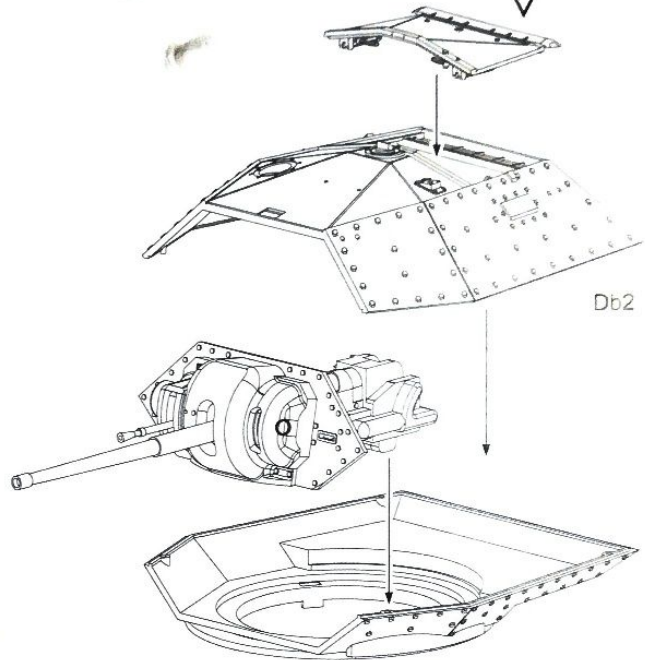
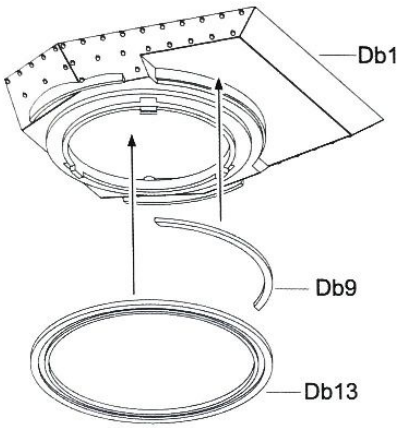

14

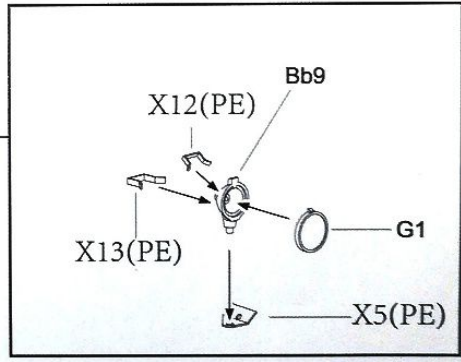
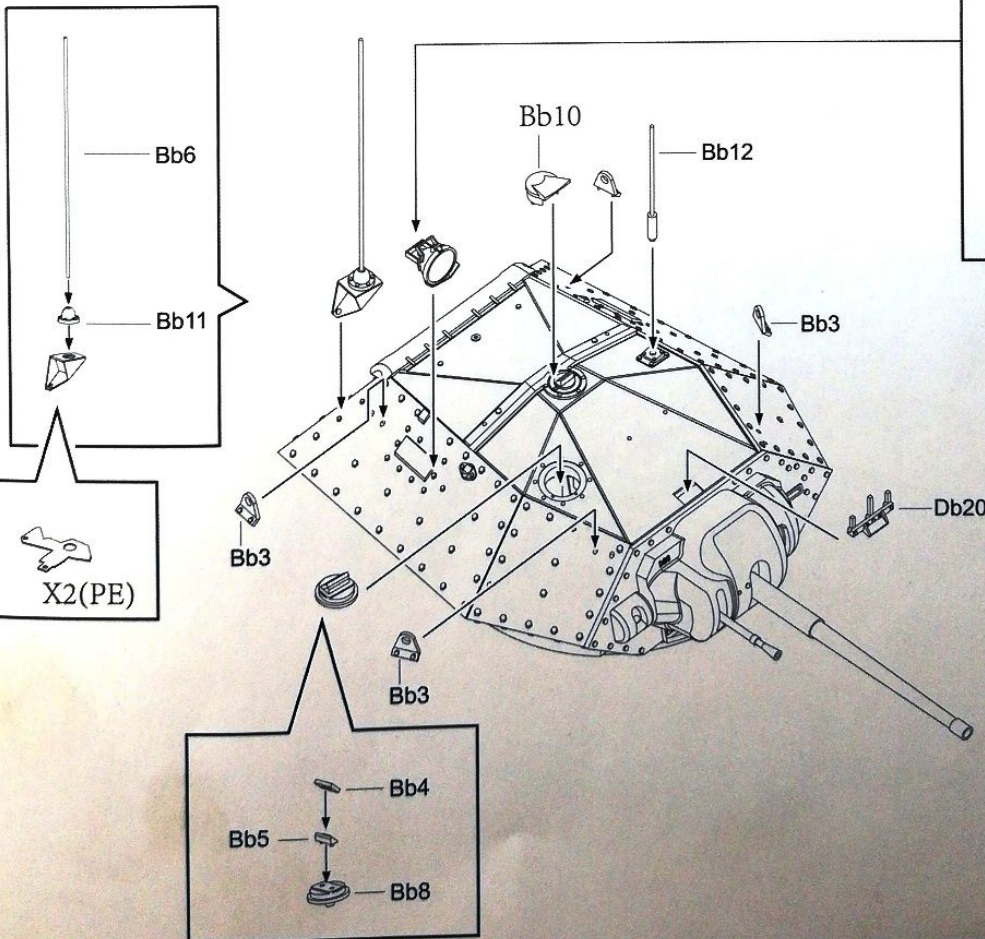



15

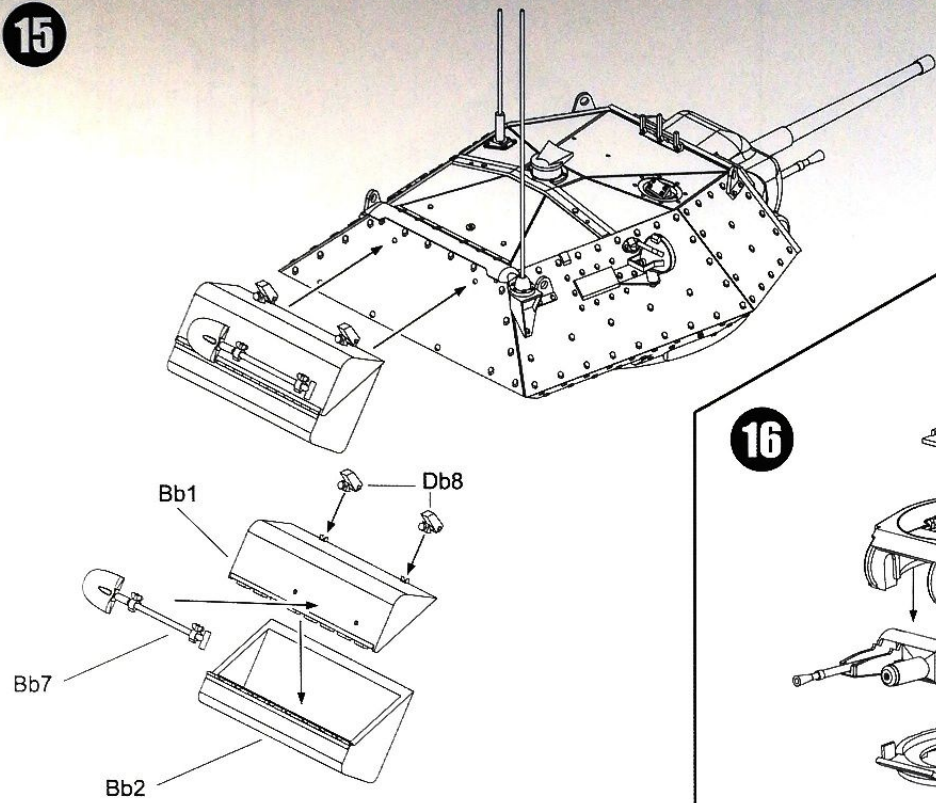

16

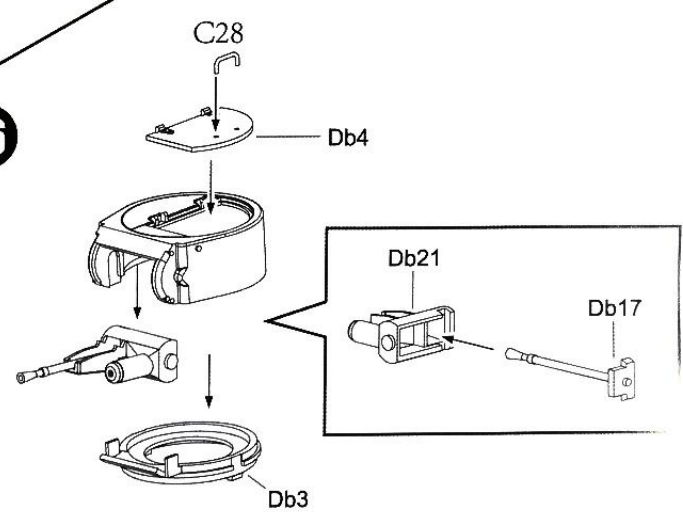

17

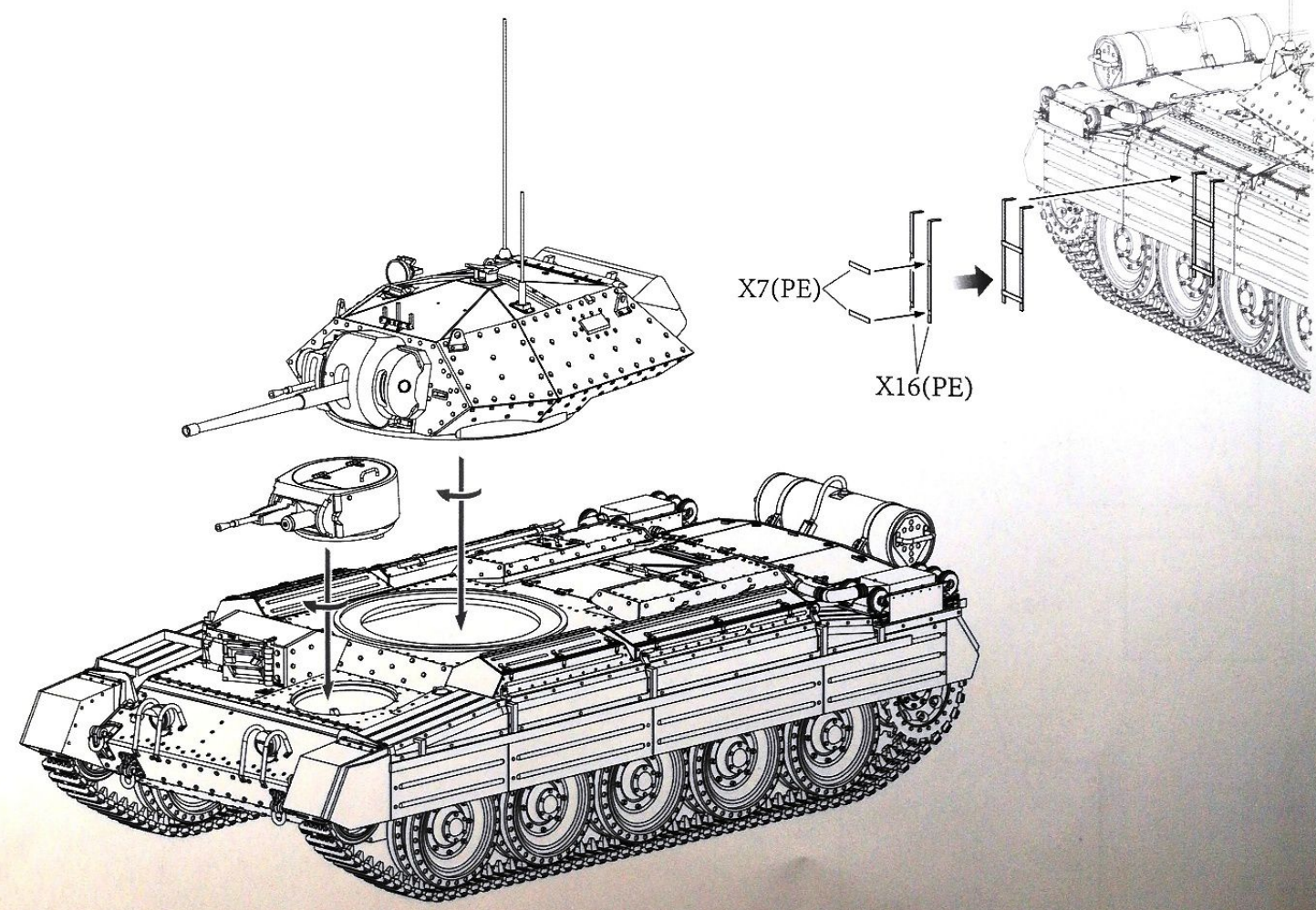



## PAINTING AND MARKING GUIDE

**BORDER MODEL REF: BT-015** 9Th armoured Brigade. El Alamein 1942.

- |  |  |   |   |
|--|--|---|---|
|  <b>A.MIG-0029</b> Desert Sand                |  <b>A.MIG-0033</b> Rubber & Tires |  <b>A.MIG-0035</b> Dark Tracks   |  <b>A.MIG-0038</b> Light Wood              |
|  <b>A.MIG-0042</b> Old Rust                   |  <b>A.MIG-0045</b> Gun Metal      |  <b>A.MIG-0094</b> Crystal Glass |  <b>A.MIG-0096</b> Crystal Periscope Green |
|  <b>A.MIG-0110</b> British Brown (1941-1942). |  <b>A.MIG-0195</b> Sylver         |   |   |



\* Not confirmed by some sources.

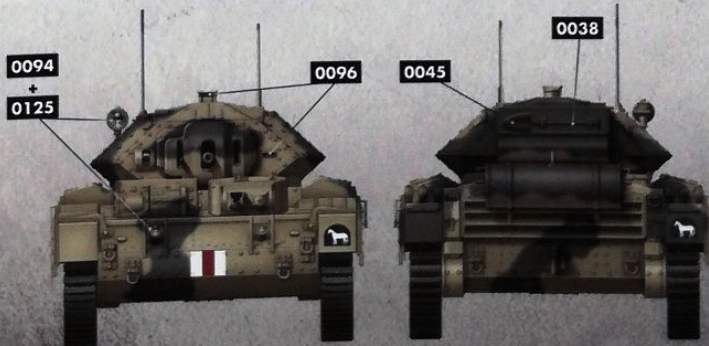
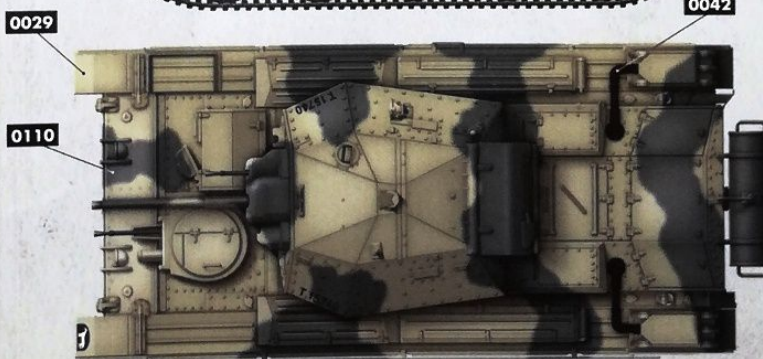









### WEATHERING STEPS WITH AMMO PRODUCTS

- |   |  |   |   |  |
|---|--|---|---|--|
| <b>1 GENERAL WASH</b><br>A.MIG-1001 Afrika Korps Wash | <b>3 STREAKING</b><br>A.MIG-1201 Streaking Grime for DAK | <b>5 TRACKS WASH</b><br>A.MIG-1002 Tracks Wash        | <b>7 HEAVY MUD</b><br>A.MIG-1702 Turned Earth | <b>9 FUEL</b><br>A.MIG-1409 Fuel Stains      |
| <b>2 FILTER</b><br>A.MIG-1505 Grey for Yellow Sand    | <b>4 RAINMARKS</b><br>A.MIG-1258 Streakingbrusher Dust   | <b>6 DUST</b><br>A.MIG-3003 North Africa Dust Pigment | <b>8 SPLASHES</b><br>A.MIG-1751 Dry Steppe    | <b>10 OIL</b><br>A.MIG-1408 Fresh Engine Oil |



## PAINTING AND MARKING GUIDE

**BORDER MODEL REF: BT-015** Beutepanzer.

 A.MIG-0030 Sand Yellow	 A.MIG-0033 Rubber & Tires	 A.MIG-0035 Dark Tracks	 A.MIG-0037 New Wood
 A.MIG-0042 Old Rust	 A.MIG-0045 Gun Metal	 A.MIG-0094 Crystal Glass	 A.MIG-0096 Crystal Periscope Green
 A.MIG-0195 Silver			

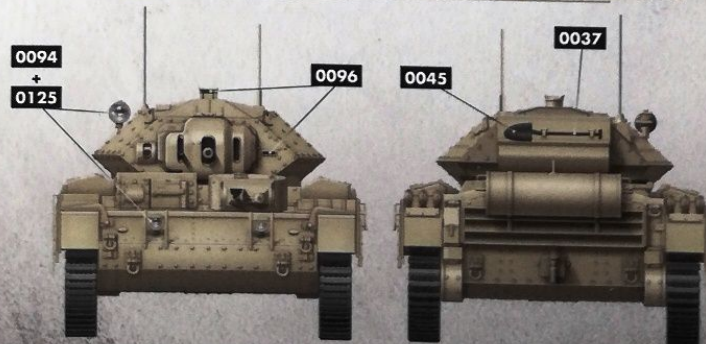
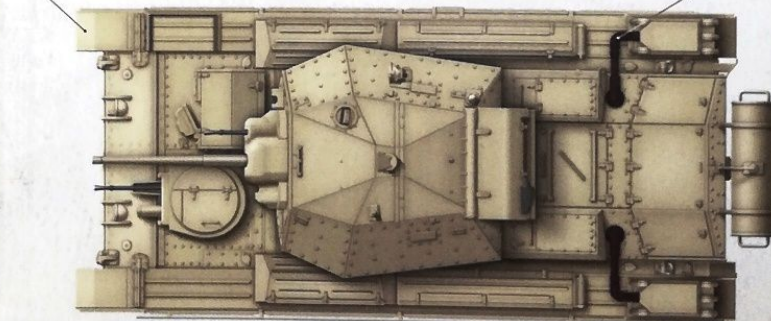
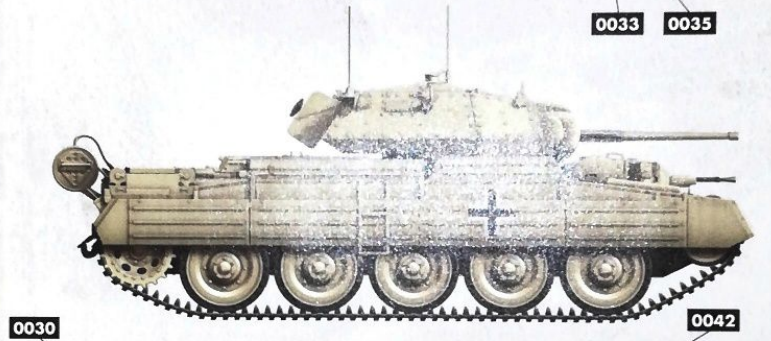

### WEATHERING STEPS WITH AMMO PRODUCTS

<b>1 GENERAL WASH</b> A.MIG-1001 Afrika Korps Wash	<b>3 STREAKING</b> A.MIG-1201 Streaking Grime for DAK	<b>5 TRACKS WASH</b> A.MIG-1002 Tracks Wash	<b>7 HEAVY MUD</b> A.MIG-1702 Turned Earth	<b>9 FUEL</b> A.MIG-1408 Fuel Stains
<b>2 FILTER</b> A.MIG-1505 Grey for Yellow Sand	<b>4 RAINMARKS</b> A.MIG-1258 Streakingbrusher Dust	<b>6 DUST</b> A.MIG-3003 North Africa Dust Pigment	<b>8 SPLASHES</b> A.MIG-1751 Dry Steppe	<b>10 OIL</b> A.MIG-1408 Fresh Engine Oil



## PAINTING AND MARKING GUIDE

**BORDER MODEL REF: BT-015** The Saint, 1942.

-  **A.MIG-0029** Desert Sand
-  **A.MIG-0033** Rubber & Tires
-  **A.MIG-0035** Dark Tracks
-  **A.MIG-0036** Old Wood
-  **A.MIG-0042** Old Rust
-  **A.MIG-0045** Gun Metal
-  **A.MIG-0094** Crystal Glass
-  **A.MIG-0099** Crystal Black Blue
-  **A.MIG-0195** Silver

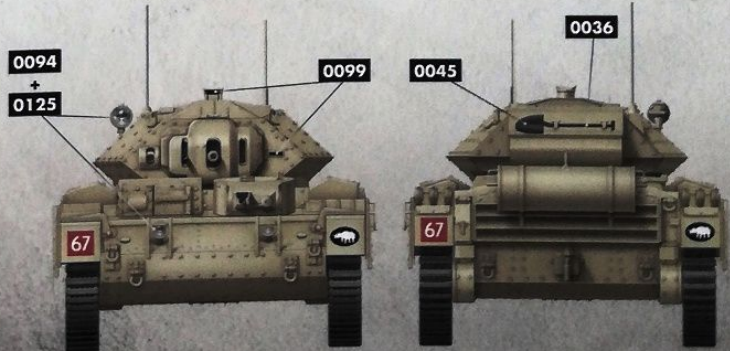
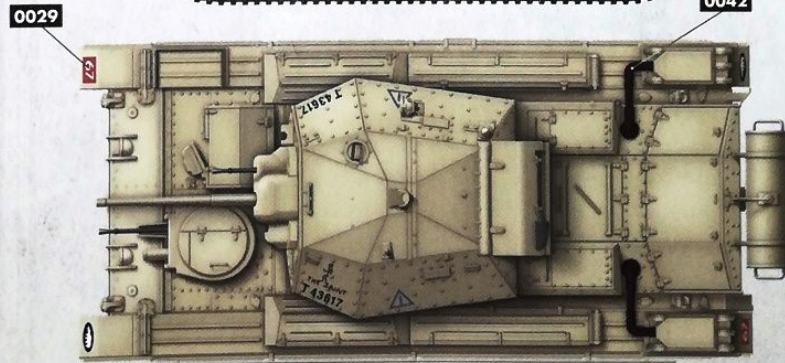
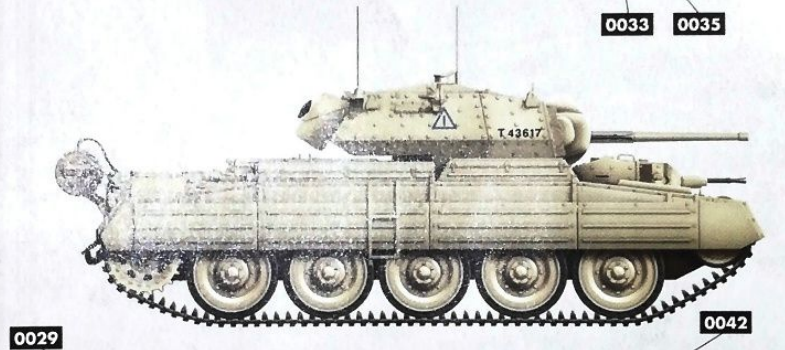

### WEATHERING STEPS WITH AMMO PRODUCTS

**1 GENERAL WASH**

**A.MIG-1001** Afrika Korps Wash

**2 FILTER**

**A.MIG-1505** Grey for Yellow Sand

**3 STREAKING**

**A.MIG-1201** Streaking Grime for DAK

**4 RAINMARKS**

**A.MIG-1258** Streakingbrusher Dust

**5 TRACKS WASH**

**A.MIG-1002** Tracks Wash

**6 DUST**

**A.MIG-3003** North Africa Dust Pigment

**7 HEAVY MUD**

**A.MIG-1702** Turned Earth

**8 SPLASHES**

**A.MIG-1751** Dry Steppe

**9 FUEL**

**A.MIG-1409** Fuel Stains

**10 OIL**

**A.MIG-1408** Fresh Engine Oil



