

1/35 sWS 60cm INFRARED SEARCHLIGHT CARRIER "UHU" 二战德军sWS红外线观测车

Great Wall Hobby™

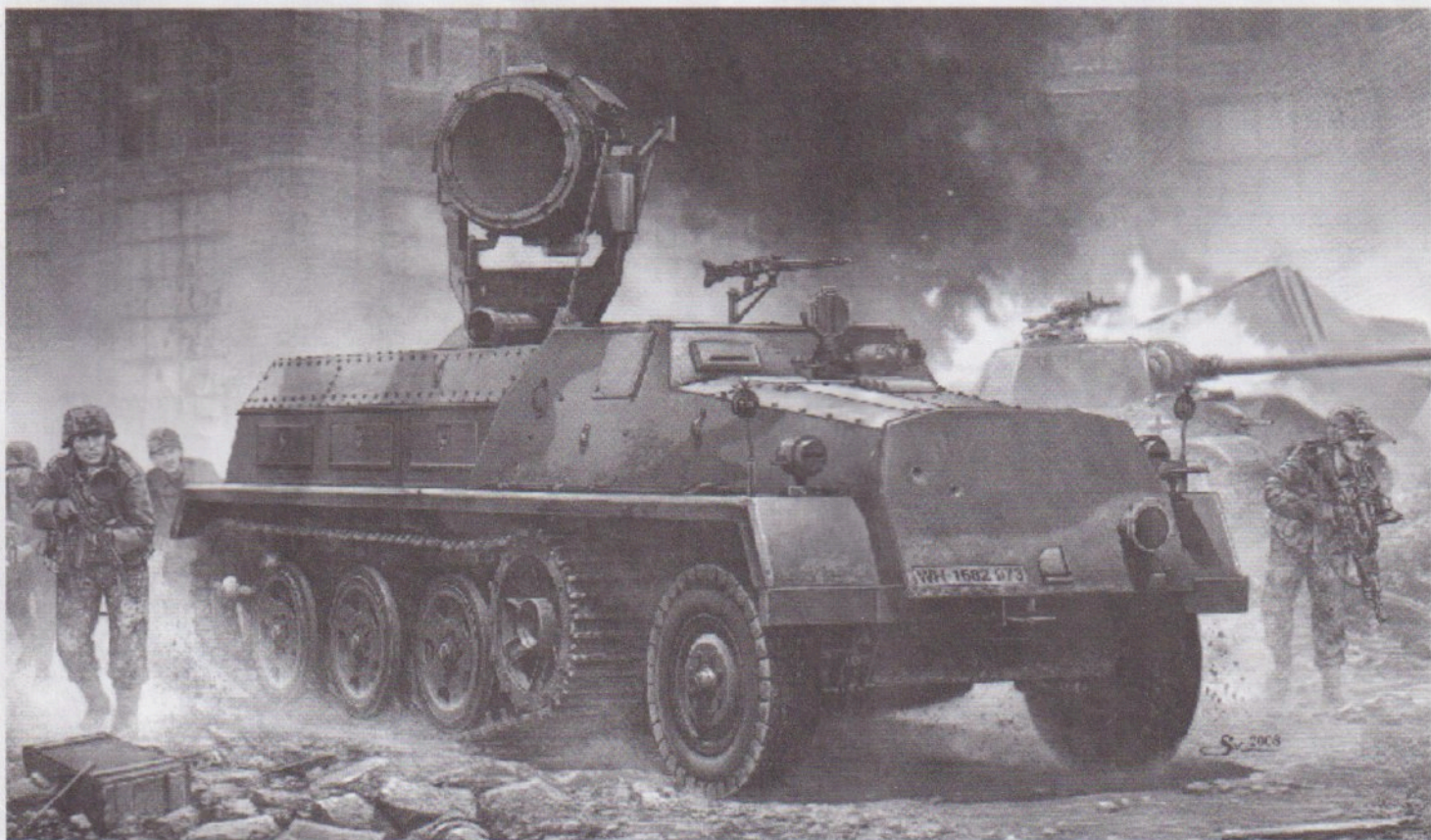

Schwerer Wehrmachtsschlepper (sWS) 半履带车的设计初衷是为了填补轻型半履带运输 Sd.kfz.250/251和重型半履带运输车Sd.kfz.6/7/9之间的空白而且必须造价低廉。希特勒于1942年5月7日下达了设计指令，因为当时俄国战场急需这样一种车辆。sWS由布辛-NAG公司设计和生产。第一辆原型车于1943年春完成。位于Tszechoslovakia的Ringhofer-Tatra工厂主要担任sWS的生产工作。该车有三种基本型号：无装甲的常规运输型，装甲型底盘和自行高炮底盘。无装甲的常规运输型拥有一个类似于卡车的驾驶室。出于节约资源的目的，sWS的设计已经尽可能的简单。而在战争的最后阶段，该车的生产又被进一步的简化。sWS拥有强大的机动性和装载能力，直到战争结束时，只有820辆sWS完工。

sWS红外线照射车是德军计划用来配合装备红外夜视装置的战车作战，而将一具60cm探照灯改装的红外照射灯安装与sWS装甲型底盘上。驾驶室前部还有一具20cm红外照射灯和F.G.1250红外夜视镜构成的夜视装置供驾驶之用。

The Schwerer Wehrmachtsschlepper was developed as a cheap solution to fill the gaps between the light (Sd.Kfz. 250/251) and heavy halftracks (Sd.Kfz. 6/7/9). A design order was issued personally by Hitler on May.7.1942, for the immediate demand of such vehicle on the eastern front.

The sWS was developed and built by B ü ssing-NAG, with the first prototype completed in spring 1943. Majority of the vehicles were produced by the Ringhofer-Tatra factory in Tszechoslovakia.. 3 basic variants existed: an unarmored prime mover, an armored version, and a mobile air defense platform. The unarmored version also featured a cabin design resembling that of a truck.

The vehicle had a simple design for the purpose of conserving resources, but was further simplified towards the end of the war,. The sWS vehicles featured great mobility and loading capacities, but only 820 were completed by the end of world war II.

sWS infrared searchlight carrier was proposed by the German to be incorporated into their night fighting groups, with a 60cm infrared searchlight mounted on the armored version of sWS. The design also featured a 20cm infrared lamp and a F.G.1250 infrared night vision scope for the driver.

△注意:

1. 勿於近火處使用膠水或油漆，並打開窗戶保持空氣流通。
2. 塗料的號碼請參考本欄以下的說明。本品本身不包括膠水和塗料。
3. 自膠架中取出部件時，應用模型專用剪，並用介刀或小挫除去多餘膠料。
4. 各圖形的含義可參考本欄以下的說明。

△CAUTION:

1. When you use glue or paint, do not use near a open flame, and sue in a well-ventilated room.
2. See below for the color list. Glue and paint are not included in this kit.
3. When you take parts off the runner frame, use the modeling scissors and trim excess plastic with a cutter or a file.
4. See below for the meaning of symbols.

△組み立ての注意

1. 接着剤や塗料は火の近くで使わないで下さい、使用の際は換気を良くして下さい。
2. 塗料指定のは下記のとおりです、接着剤や塗料は入っていませんので別に求めて下さい。
3. 部品をランナーから切り離す時は模型用ハサミ等を使い、余分な部分はカッターやヤスリ等で仕上げして下さい。
4. 組立図のサインマークは下の説明を御覧下さい。

把孔填平 Fill hole 穴を埋めてください	水印貼紙 Apply Decal デカールをはって下さい	切去 Cut off 切り取って下さい	不用膠水粘合 Do not cement 接着しないでください	鑽孔 Open hole 穴をあけて下さい	另一側相同制作 Do the same on the opposite side 反対側も取り付けます	等待放水干燥2-3分钟 Wait 2-3 minutes until the cement dry 接着剤が乾くまで 2-3分待ちます
瞬間接著劑 Instant glue for metal 瞬間接著劑 (金屬用)	注意 Be careful 注意して下さい	膠水粘合 Cement Together 接着しないで下さい	選擇使用 Optional どちらかを選んで下さい	磨去 Remove 磨くこと	制作二組 Make two sets 2個作って下さい	彎折 Bend 折り曲げて下さい

PARTS LIST 零件表

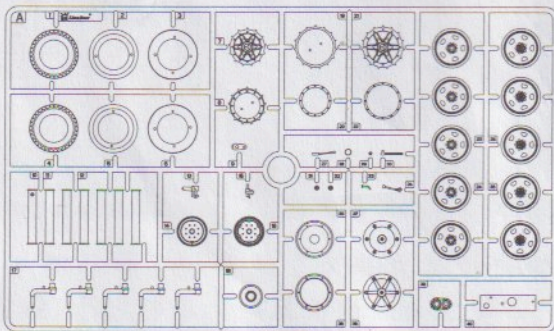

A×2

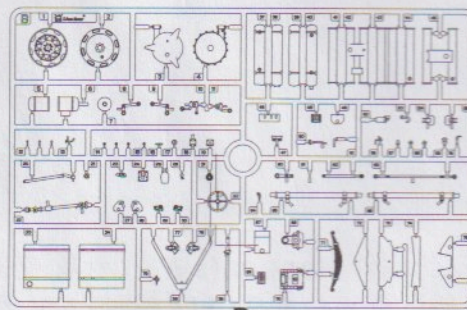

B

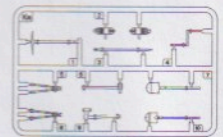

Ka

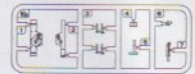

Kb

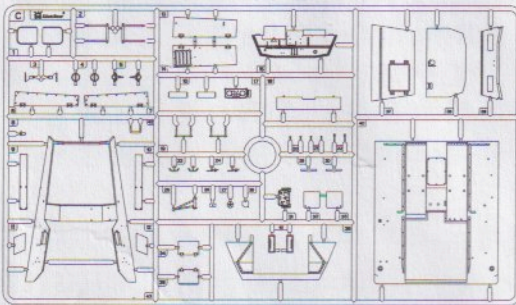

C

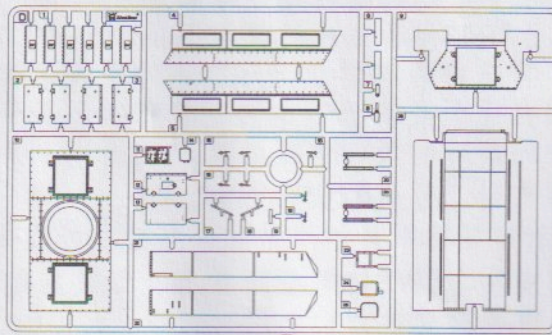

D

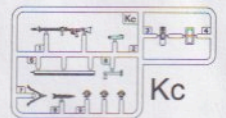

Kc

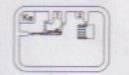

Ke

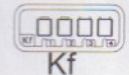

Kf

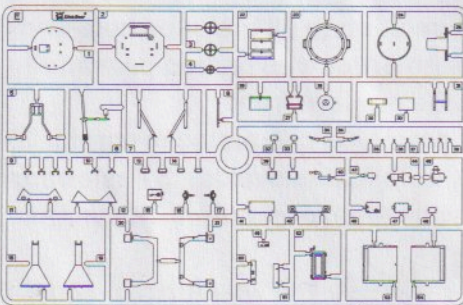

E

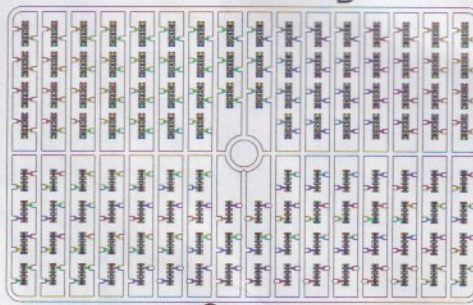

x2

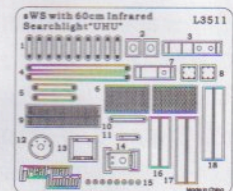

蚀刻片
PE

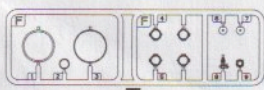

F

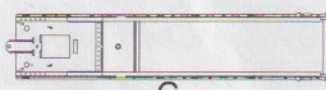

G



H

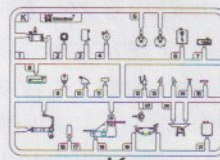

K

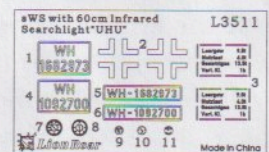

水貼
Decal

1

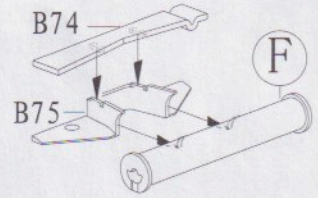
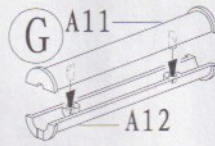
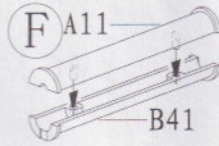
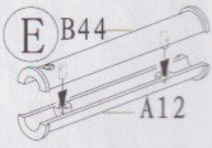
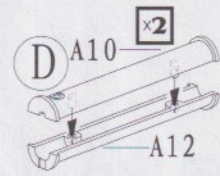
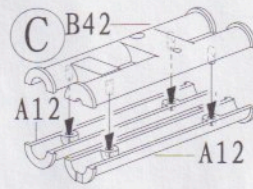
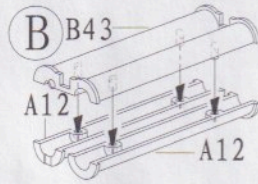
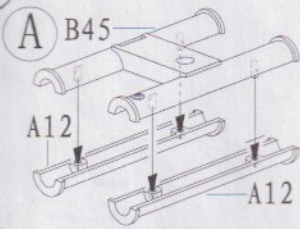

2

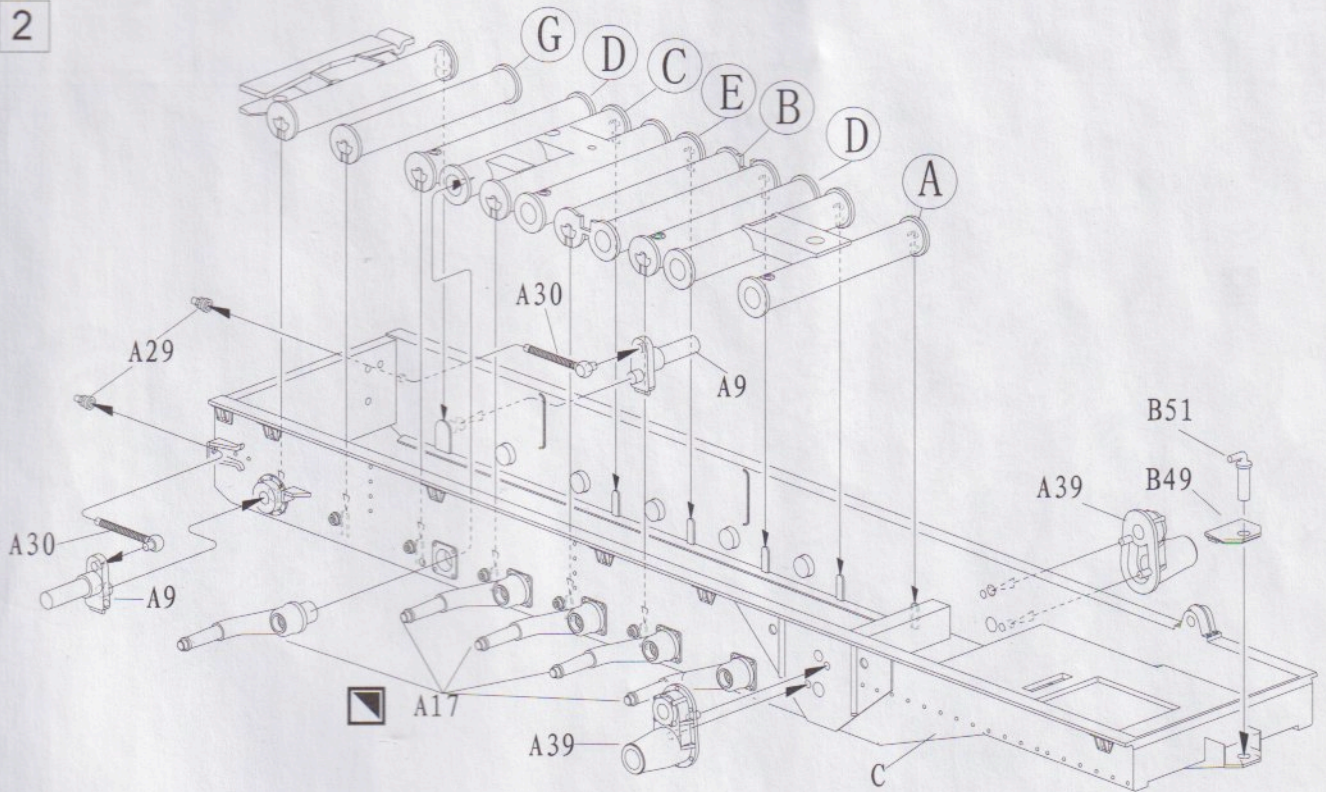

3

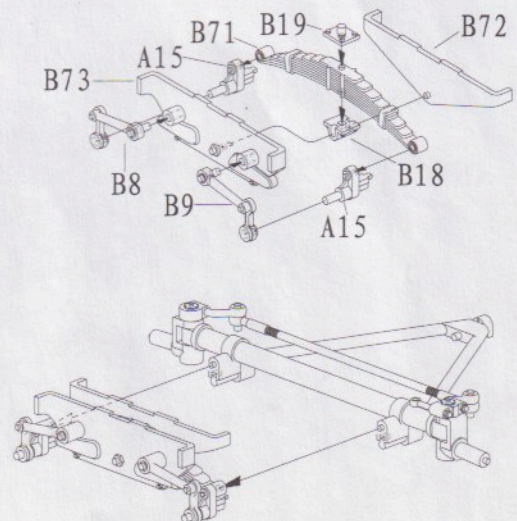
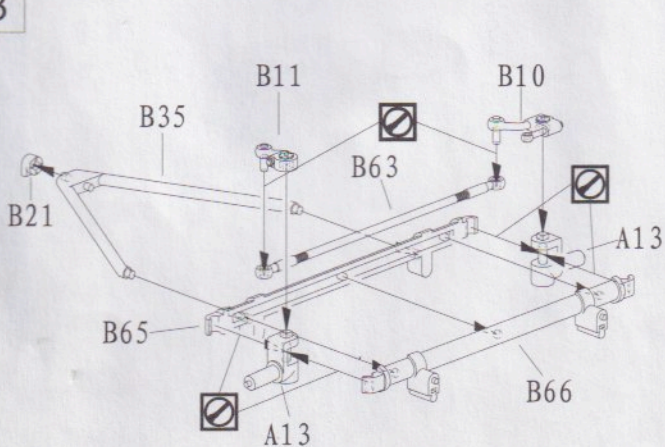

7

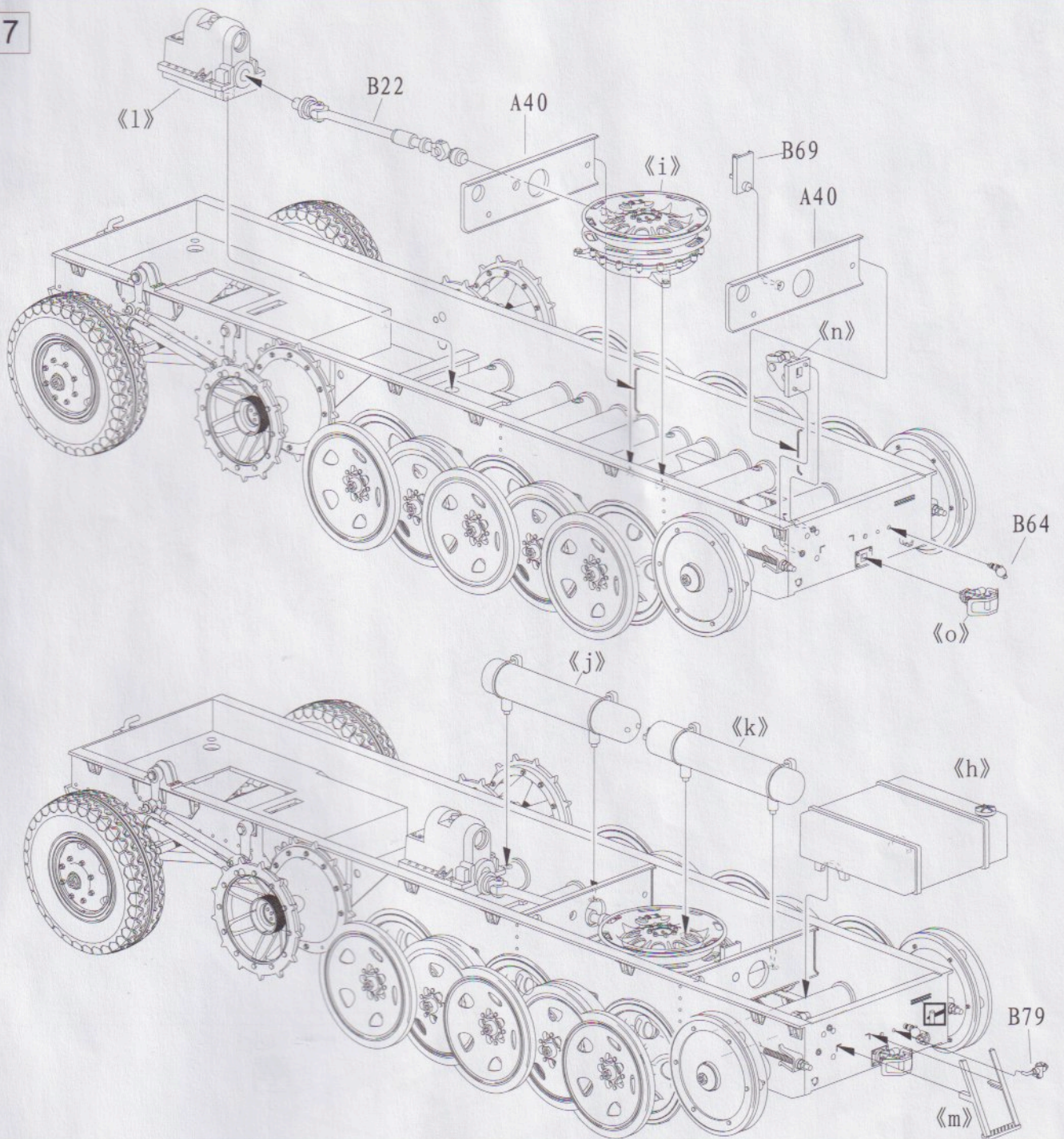

8

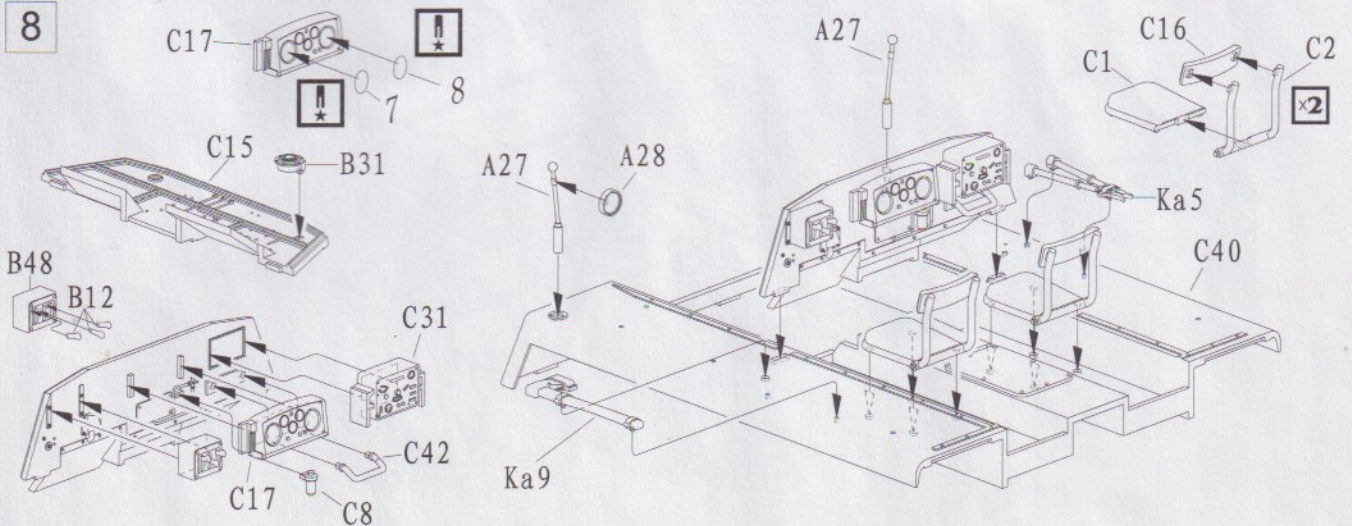

9

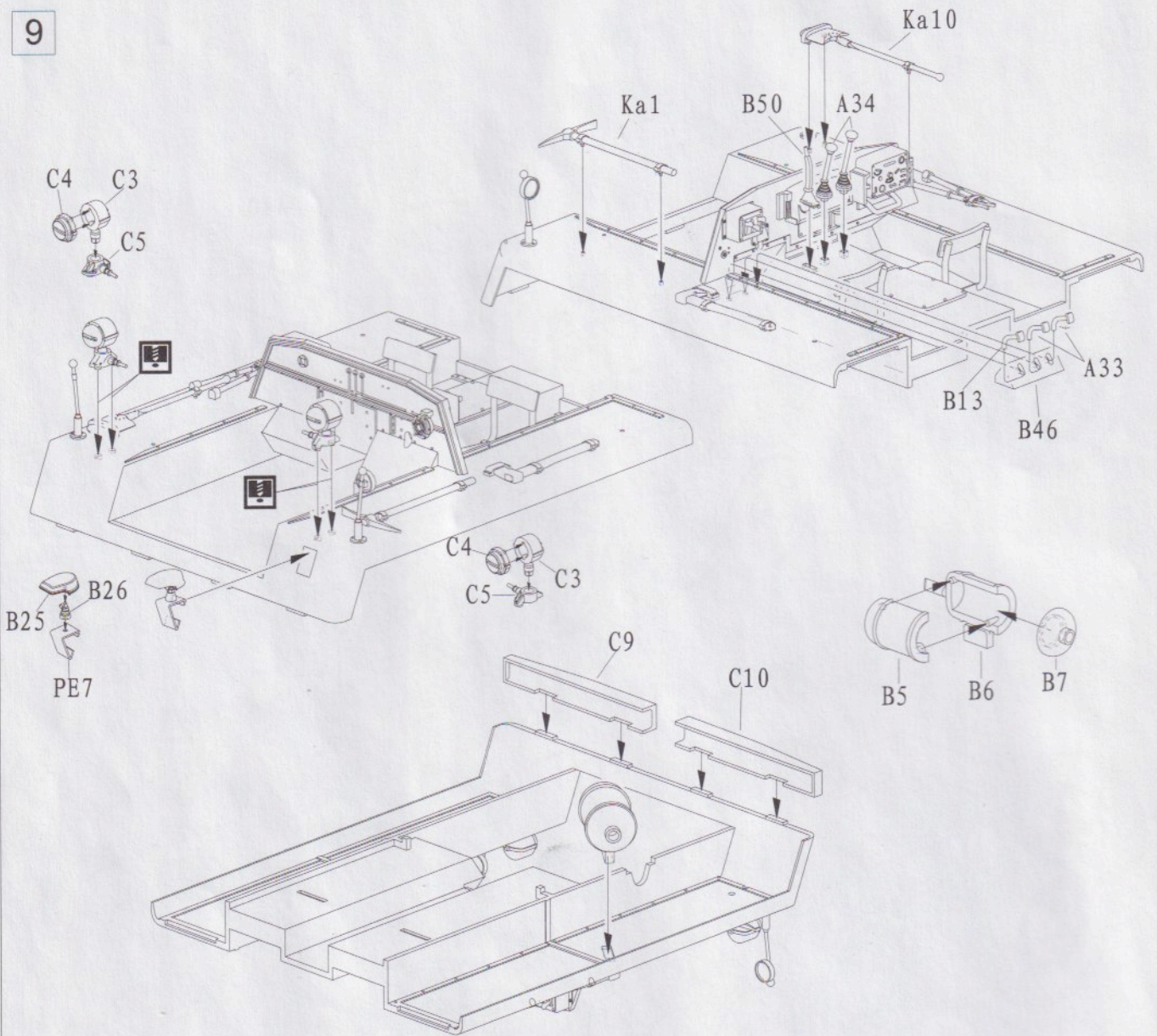

10

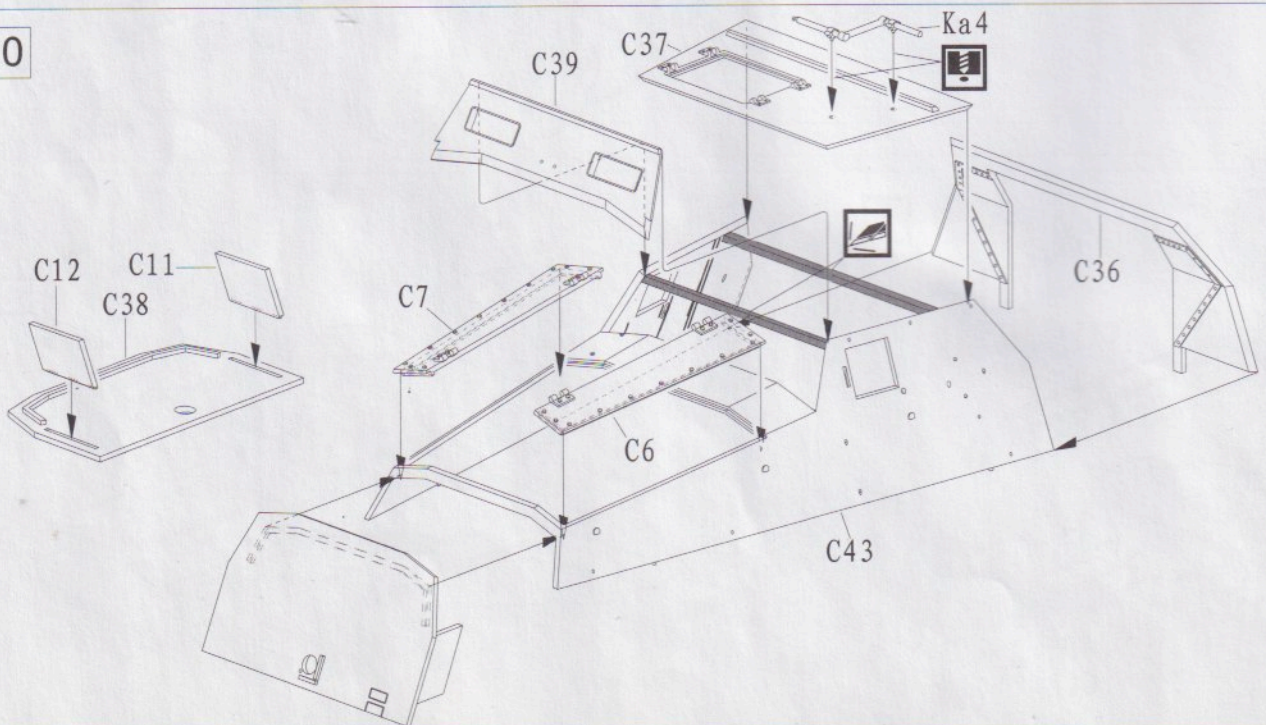

11

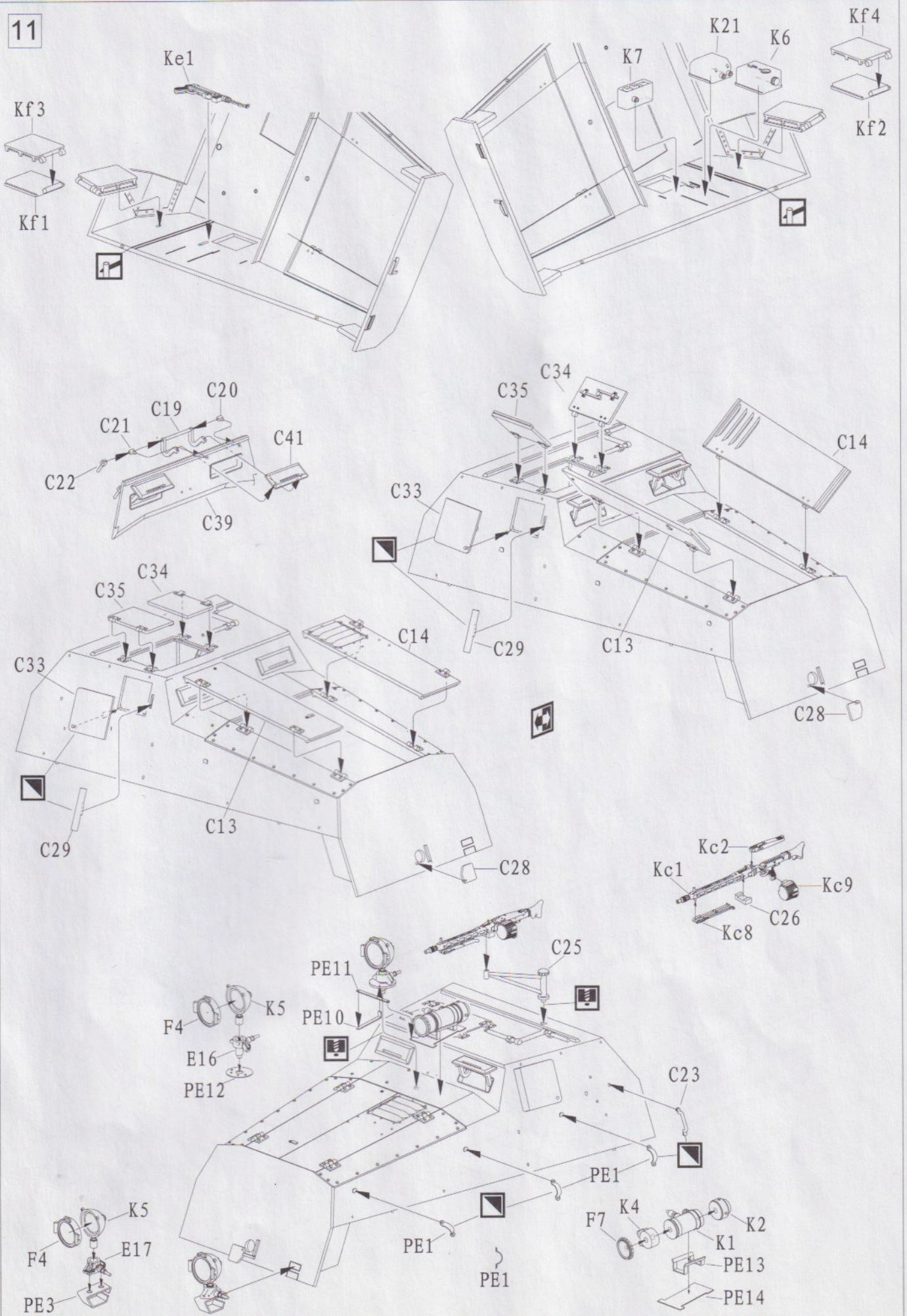

12

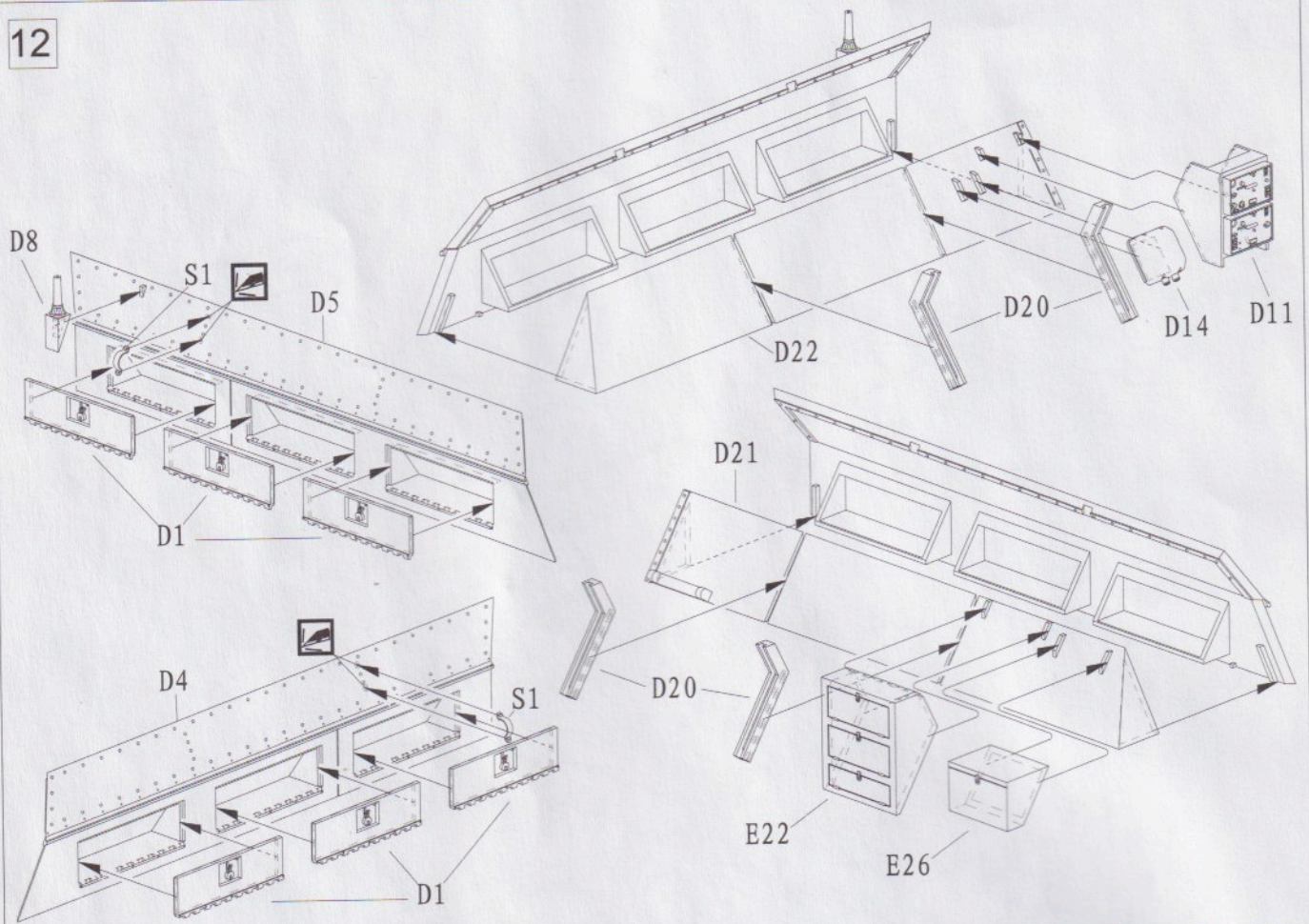

13

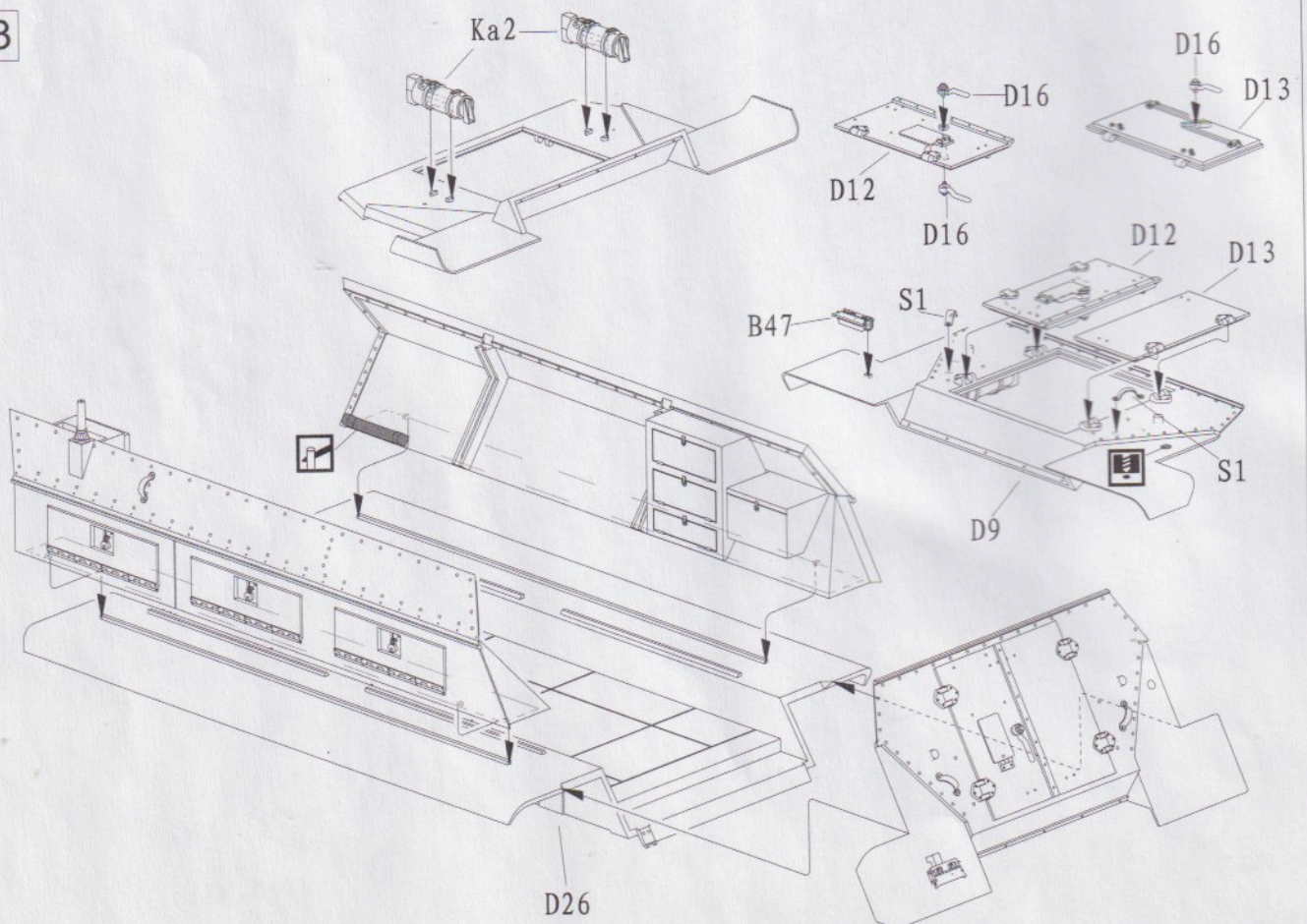

14

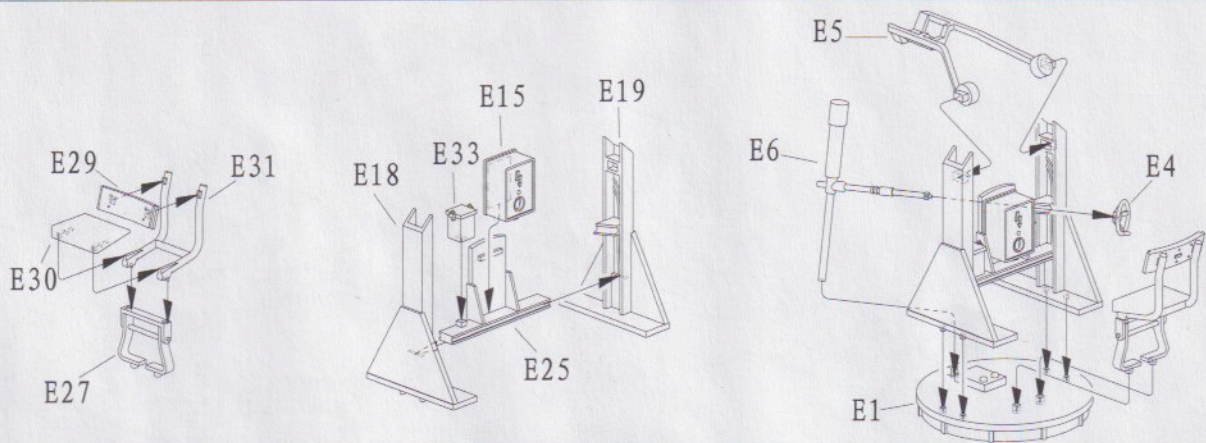

15

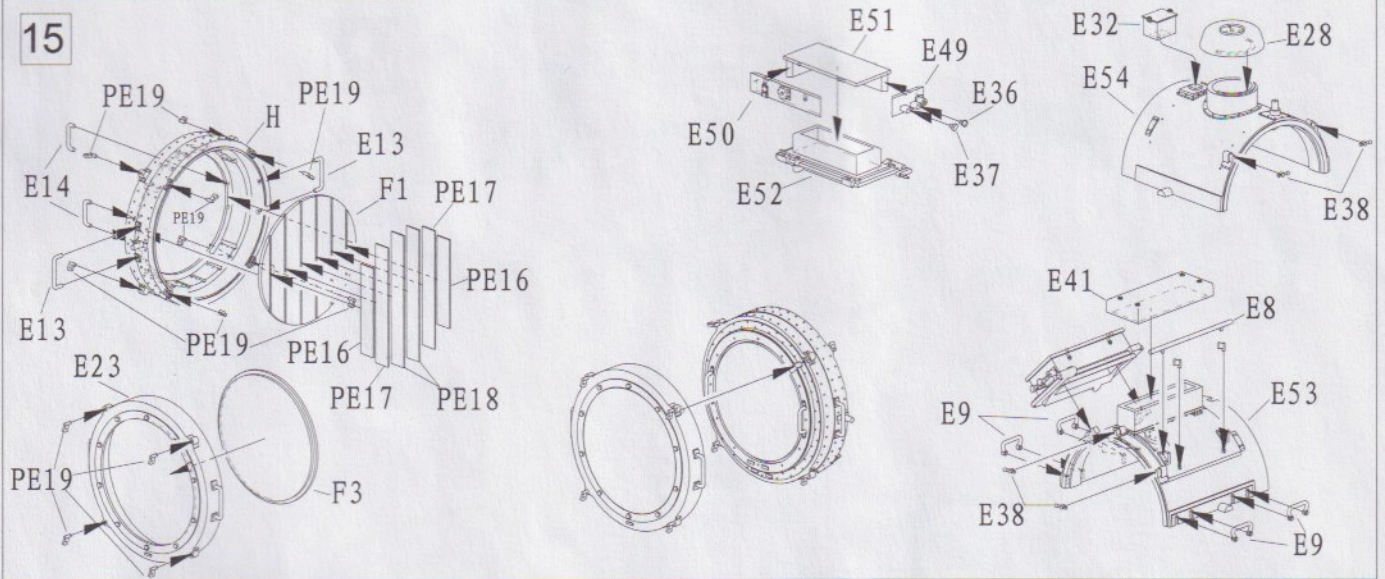

16

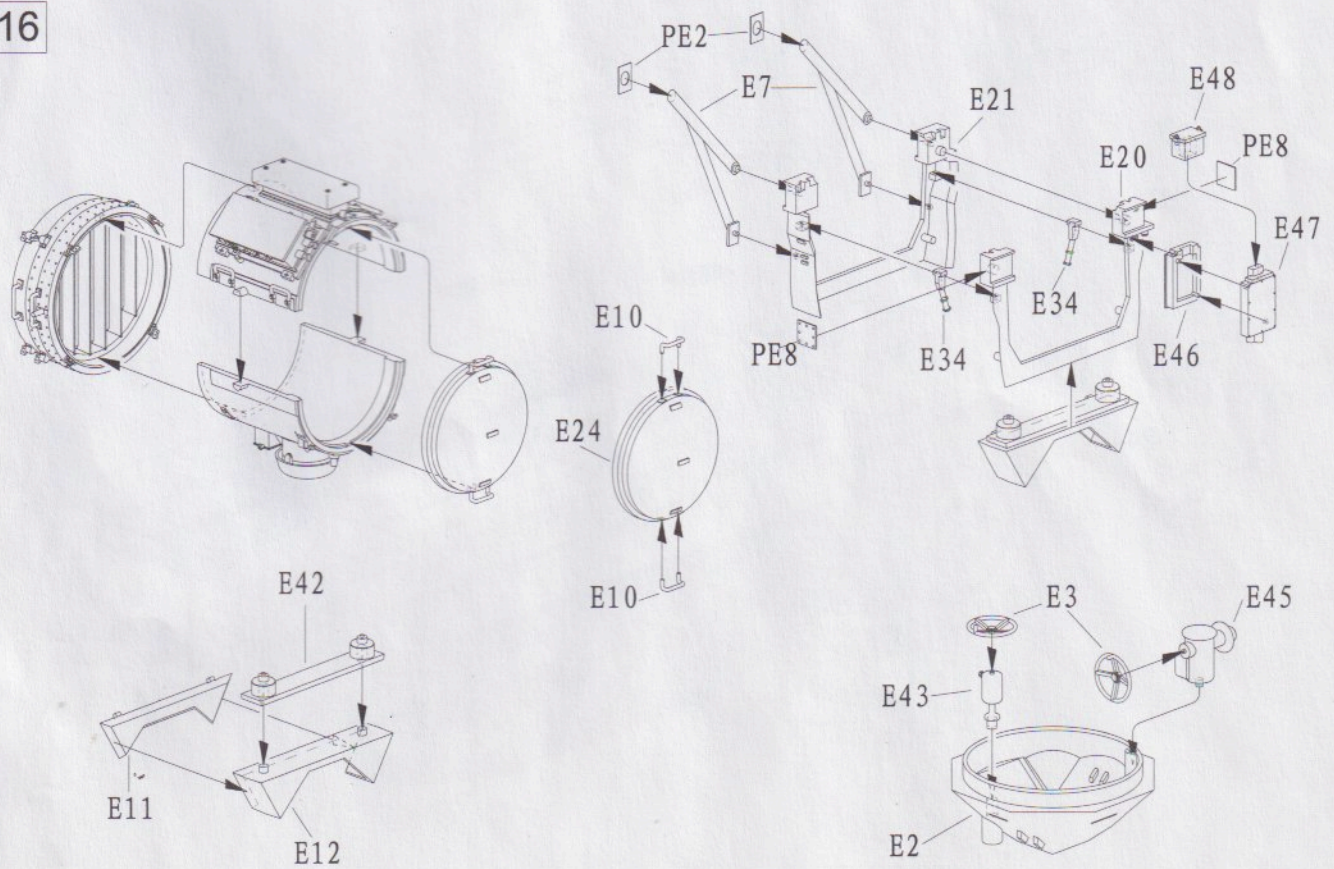

17

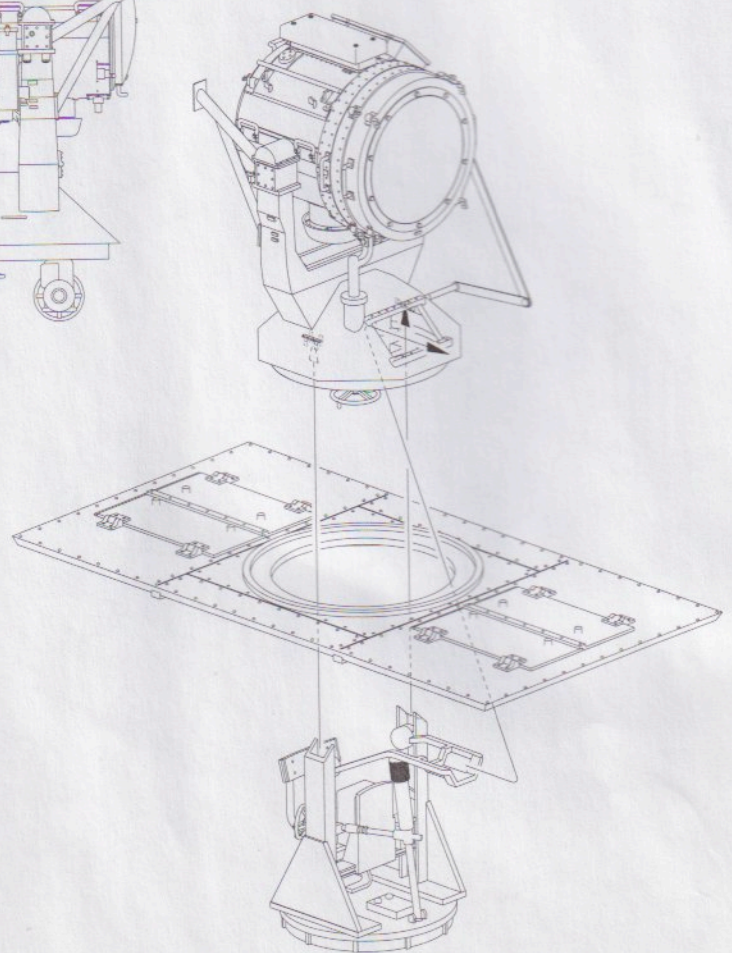
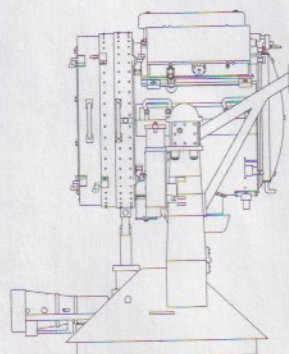
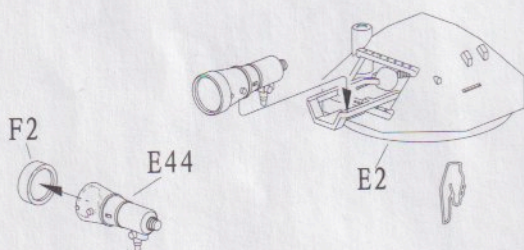
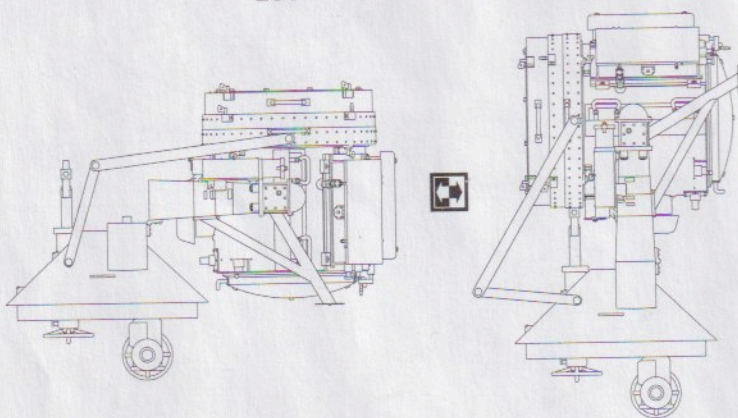
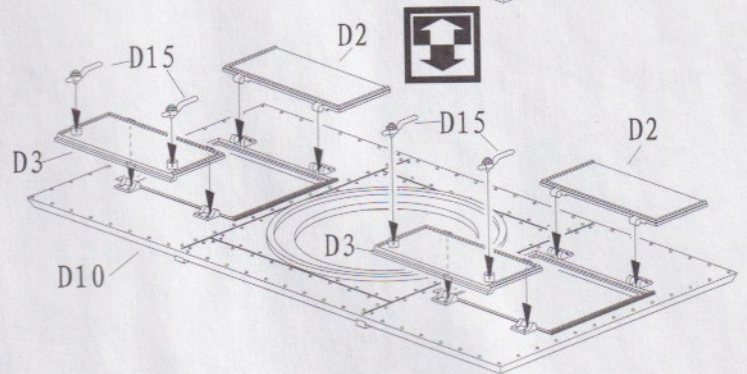
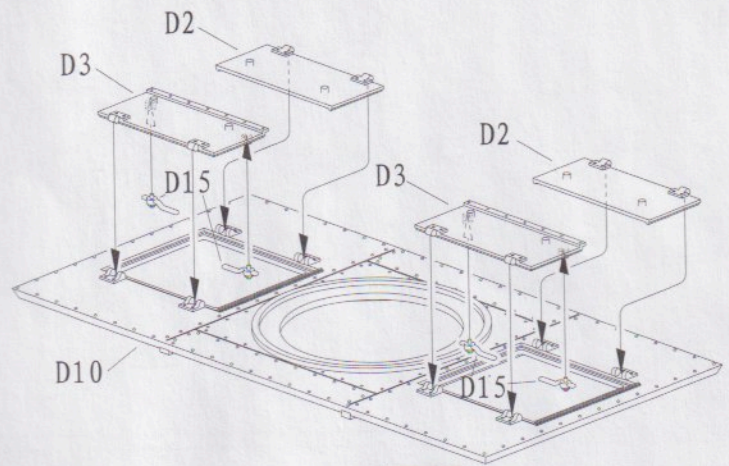
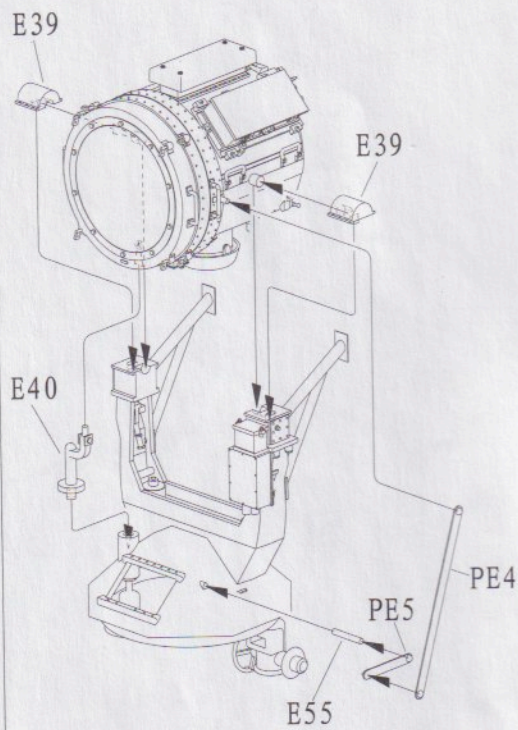

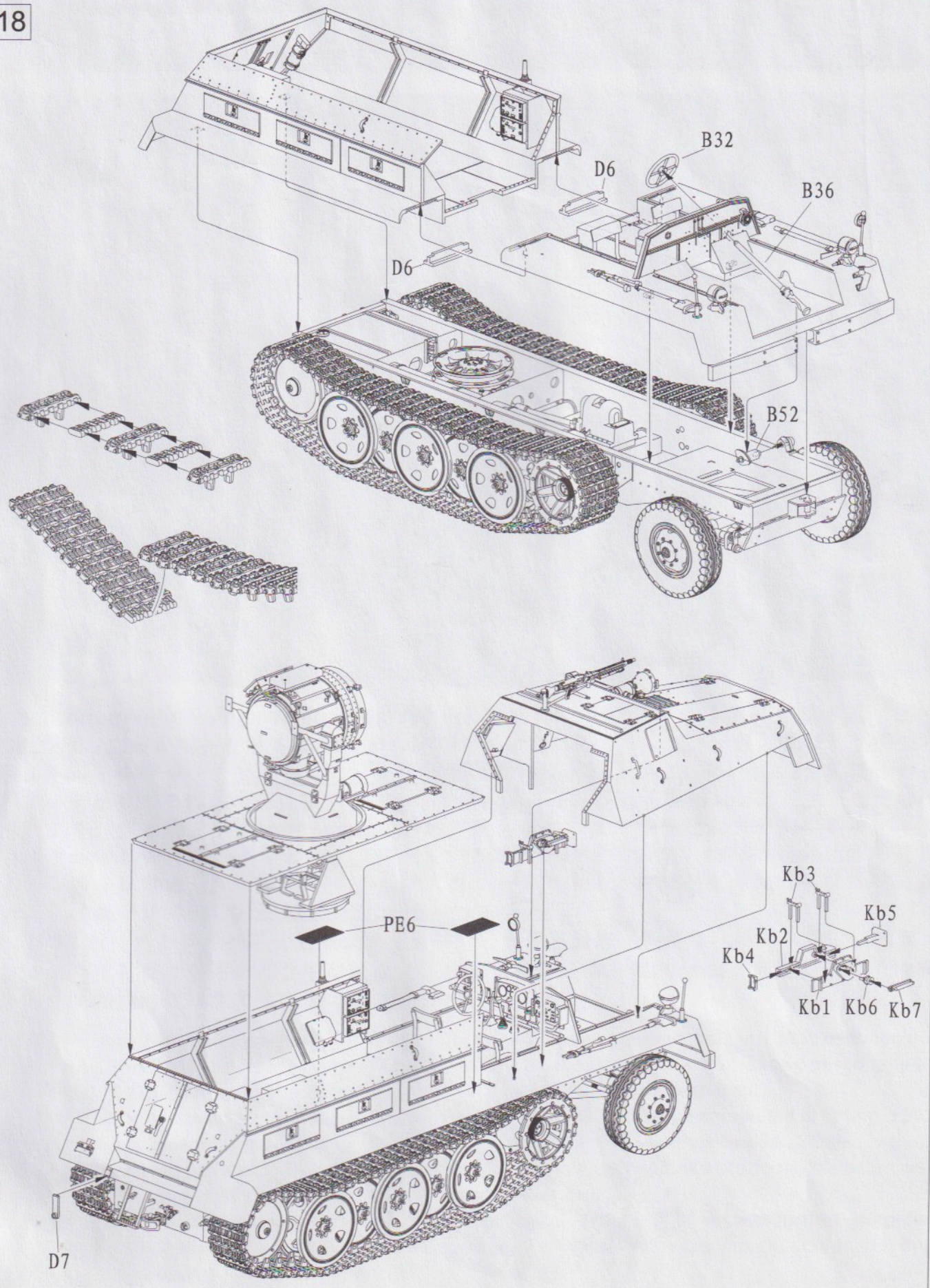

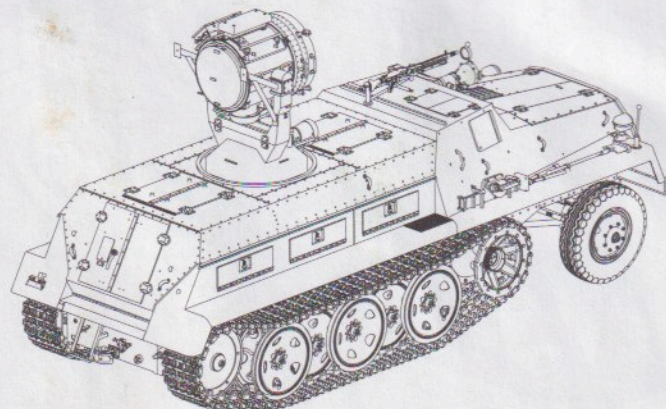
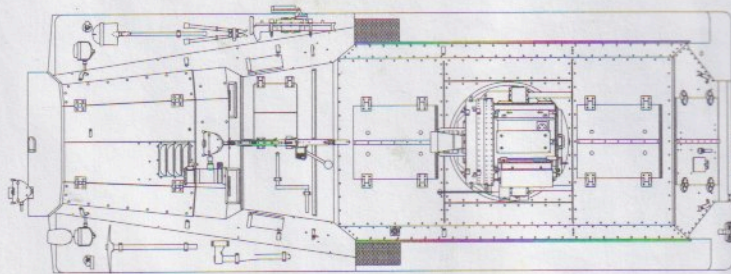
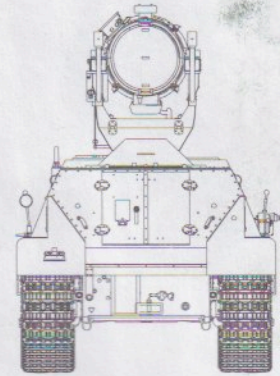
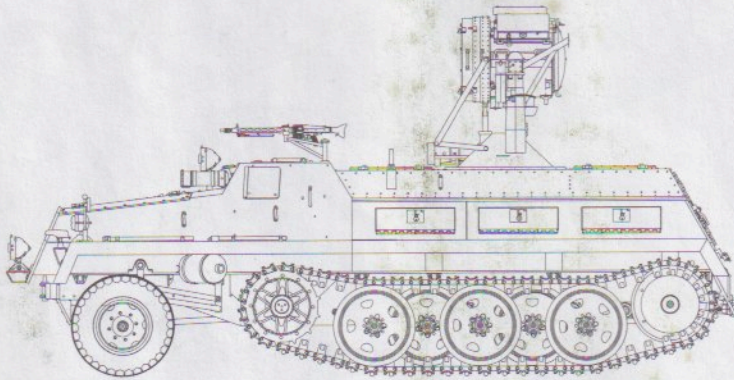
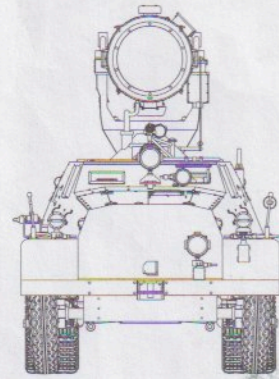
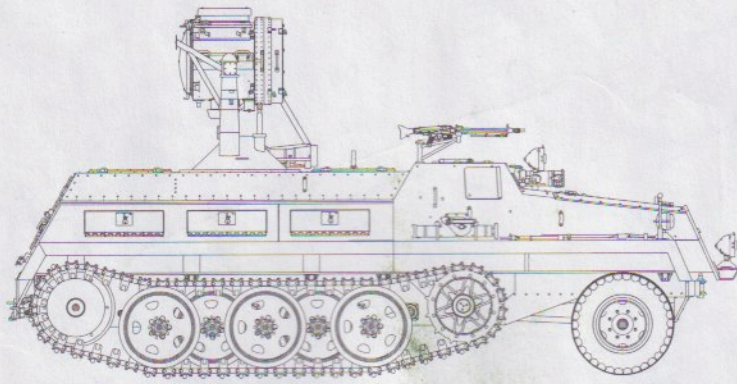

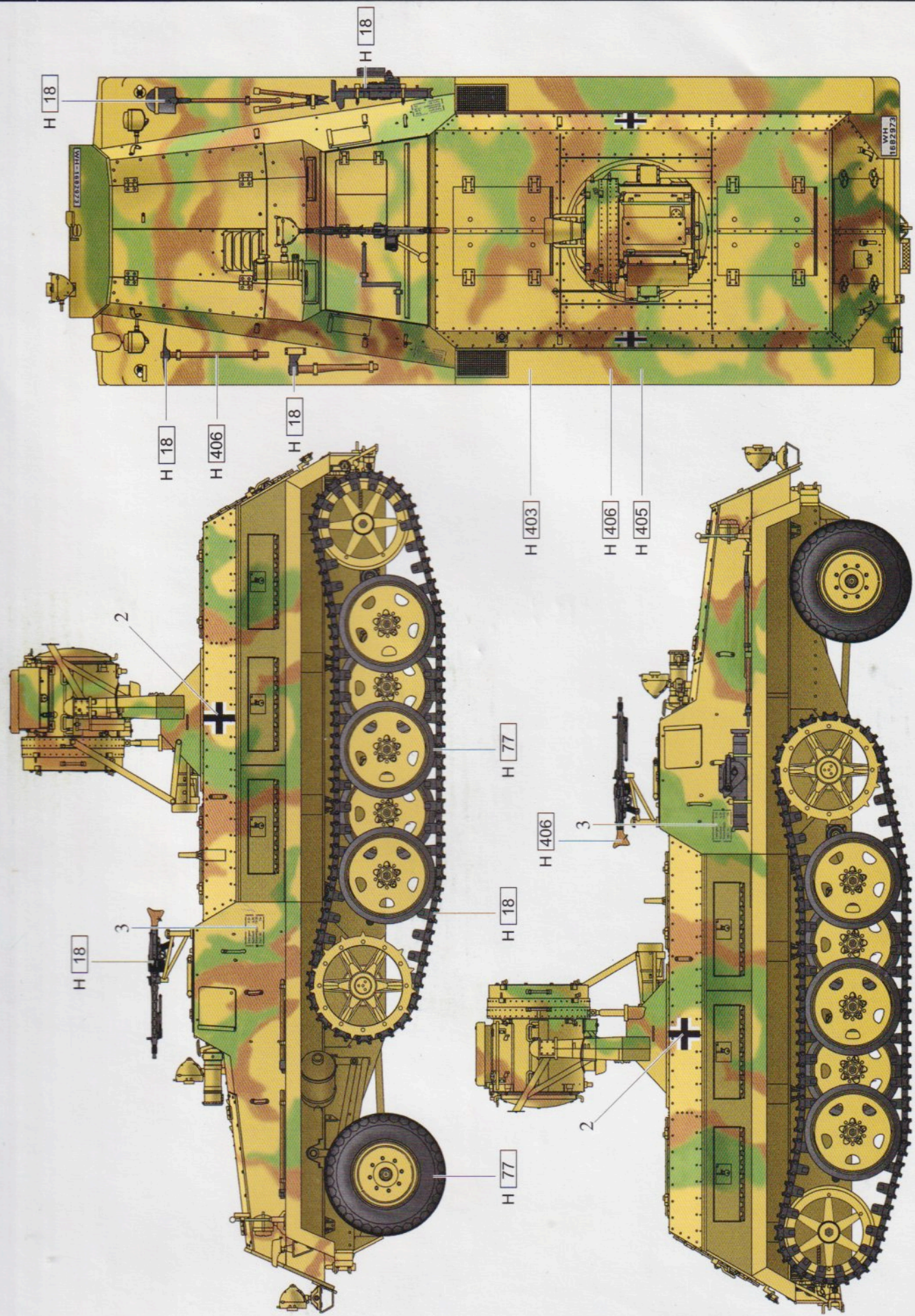

H 1 GSI CREOS CORP. HOBBY COLOUR

H 403 暗黄色 DARK YELLOW

H 405 橄榄绿 OLIVE GREEN

H 406 棕色 CHOCOLATE BROWN

H 77 轮胎黑 TIRE BLACK

H 18 黑铁色 STEEL

