

P72033 P-40 Wing Bomb Racks
(w/plywood support boards)
1/72 for Special Hobby kits

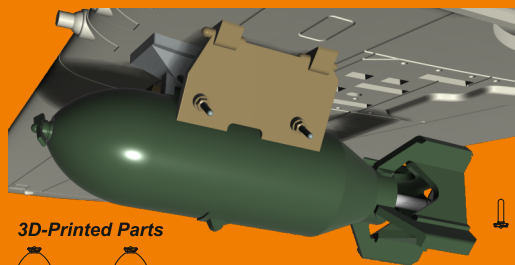

3D-Printed Parts

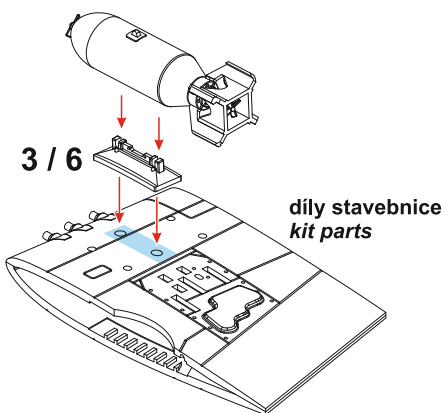
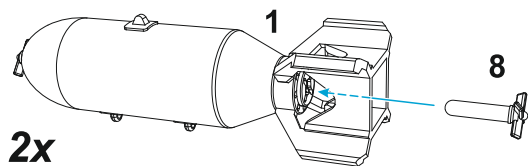
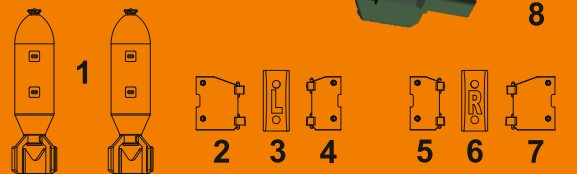

Ohnuté 3D tisky narovnejte ponořením do horké vody, srovnejte je a zchladte studenou vodou. K lepení použít kyanoakrylátové lepidlo! Kontaktní plochy doporučujeme před lepením odmastit. Různé drátky a tyčinky nejsou přiloženy.

Bent 3D printed parts: put them into hot water, straighten them and cool them in cold water. For best result use cyanoacrylate glue! Ungreasing contact areas is recommended before gluing. Wires and rods not included.

www.cmkkits.com
www.specialhobby.eu
www.facebook.com/specialhobby/



OTHER 1/72 CMK SETS

Special Hobby also offers 1/72 3D printed set P72012 Typhoon Mk.I Engine

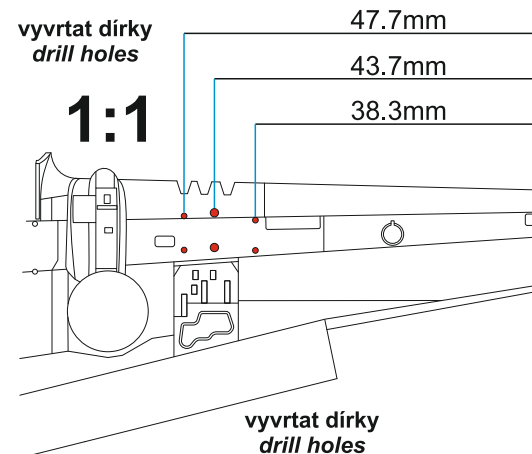
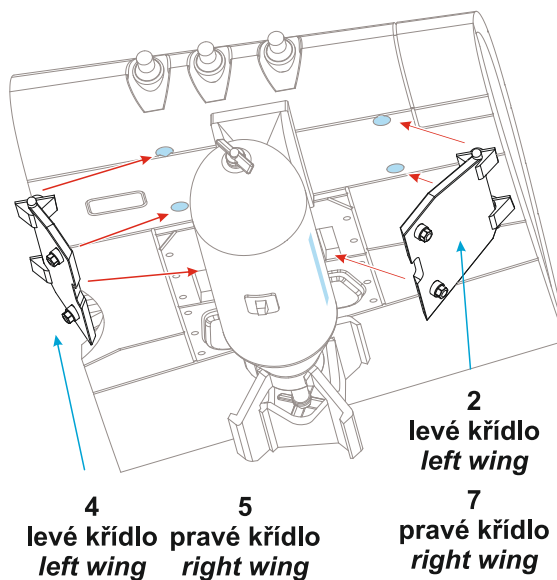
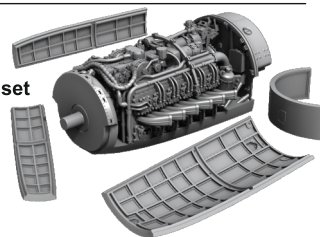

vyvrtat dírky
drill holes

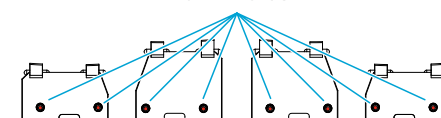

Special Hobby 2024

Special Hobby, Mezilesí 718, CZ - Praha 9, 193 00, e-mail: office@specialhobby.eu

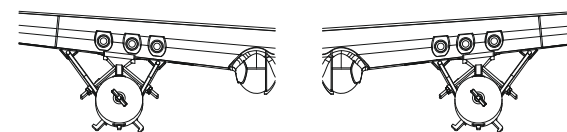
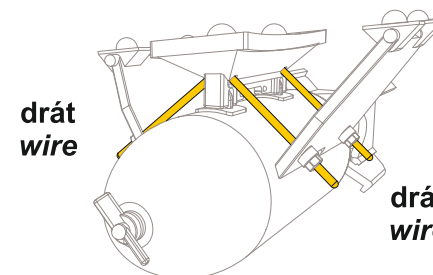

Visit our official website and e-shop at
www.cmkkits.com
www.specialhobby.eu
www.facebook.com/specialhobby/