

# CV3/33 Tankette Serie II (Early Production)

CV3/33轻战车系列II(前期型)

1/35 SCALE



The Italian government purchased four British Carden-Lloyd Tankettes in 1929 and produced their own vehicles in modified form. The first was the Carro Veloce CV-29 which served as a pilot model for the CV-33 which entered production in 1933. Fiat of Turin and Ansaldo of Genoa were chosen as the manufacturers, producing around 300 of the CV-33 model. The Tankette was usually referred to as a Light Tank in Italian service. Construction was of riveted rolled armour plate, frontal armour being 14mm. Combat weight was 3.2 tons. The CV-33 was armed by a single 6.5mm machine gun. Power was provided by a 43bhp Fiat SPA petrol engine giving a maximum speed of 46 km/h. The CV-33 was widely used and many were exported to friendly nations. It saw action with the Italian army during the North Africa campaign. The CV-33 was replaced by the CV-35 in 1936, the only major difference was bolted construction to ease manufacture and repair and twin 8mm machine gun mount. Most CV-33's were rebuilt to CV-35 standard from 1938 and were designated the CV-33 Serie II.

Short Story by Phil Greenwood

1929 erwarb die italienische Regierung vier British Carden Lloyd Tanketten und fertigte danach die Fahrzeuge eigenständig in abgewandelter Form. Zuerst kam der Carro Veloce CV-29 als Prototyp. Darauf folgte ab 1933 das Model CV-33. Von diesem Typ wurden bei Fiat (Turin) und Ansaldo (Genova) ungefähr 300 Stück hergestellt. Der Aufbau entstand aus genieteten Walzstahlplatten mit einer Frontpanzerung von 14mm. Das Gefechtsgewicht betrug 3,2 Tonnen. Als Bewaffnung diente ein 8mm MG. Mit dem 43 PS Fiat SPA Benzinmotor waren 46 km/h möglich. Der CV-33 war weitverbreitet und wurde häufig in befreundete Länder exportiert. Ab 1936 kam als Nachfolger der Typ CV-35. Dieser war zur Vereinfachung der Produktion und Wartung geschraubt und besaß ein 8mm Zwillings MG. Die meisten CV-33 wurden 1936 auf den CV-35 Standard gebracht und als CV-33 Serie II bezeichnet. Im italienischen Heer wurde die Tankette als leichter Panzer eingestuft. Der Haupteinsatz erfolgte bei der italienischen Panzertruppe während der Kämpfe in Nordafrika.

TRANSLATION © Michael Knoblich ACADEMY EURO

意大利政府于1929年购买了四辆英制的卡登·劳埃德超轻型战车，经修改后而生产了自己的产品。首先以卡洛·韦洛切公司的 CV-29 作为试点型号，其后在1933年正式生产命名为 CV-33。都灵的非亚特公司和热那亚的安萨尔多公司被选定为生产的厂家，约生产了 300 辆 CV-33 左右。意大利通常把这些轻型战车充当作轻型坦克使用。设计为铆接式冷轧钢板，前端装甲为 14 毫米。战斗重量为 3.2 吨。CV-33 装备了一挺 6.5 毫米机枪。动力由一台 43 匹马力的菲亚特汽油发动机提供可达最高 46 公里的时速。CV-33 被广泛出口到其他友好国家。这车均参与了意大利军队在二战北非的主要行动。CV-35 于 1936 年取代了 CV-33，其唯一的主要区别是安装了双联装的 8 毫米机枪和车身装甲的设计，用以纾缓生产和维修的压力。于 1938 年大多数的 CV-33 被修改，提升为 CV-35 的标准，被称作 CV-33 系列 II。

# ILLUSTRATION 图示说明:

## CORRECT METHOD FOR APPLYING DECALS : HINWEISE ZUM ANBRINGEN DER DECALS : 正确使用水贴纸的方法:

1. Clean model parts surface with wet cloth. Entsprechende Stellen am Modell feucht reinigen.  
将需要贴水贴之部位表面擦干净。
2. Cut out the decal parts and dip them in cold water for 15 ~20 seconds. Decal ausschneiden und für 15-20 Sek. ins Wasser legen.  
将所需之贴纸剪下泡在清水里约15至20秒。
3. Place it on correct position of the model kit. Decal an der richtigen Stelle auflegen.  
将湿透之贴纸取出置放于正确之位置旁。
4. Slide off the decal from the base paper on to the model kit surface with a cotton stick. Decal mit Wattestäbchen festhalten und Papier darunter wegziehen.  
用棉花棒轻推贴纸表面使其从底纸滑出至模型表面之正确位置。
5. When decal get dry then complete. Decal mit Papiertuch andrücken und trocknen.  
待其自然干透后即完成。

## ICON INSTRUCTION: 图标说明:



Open Hole  
Loch bohren  
钻孔



Remove  
Abtrennen  
切除



2 Sets needed  
Vorgang wiederholen  
同样的制作二组



Bend  
Biegen  
曲折



Optional  
Auswahl  
可以选择采用



Apply Decal  
Decal anbringen  
贴水贴纸



Instant Glue For Metal  
Sekundenkleber verwenden  
瞬间接着剂,金属用



Fill Hole  
Verspachteln  
把孔填平



Do not cement  
Nicht kleben  
不用粘合

## COLOR SUGGESTION: FARB-TABELLE: 涂装指引:

Color	涂料表	MR. Hobby	Hobby Color	Humbrol	Tamiya	
Steel	Stahl	黑铁色	H-18	C-28	53	/
Tyre black	Reifenschwarz	轮胎黑	H-77	C-137	85	/
Sand		沙黄色	H-78	C-38	66	XF-62
Rust	Rust	铁锈色	H-334	/	113	/
Dark Green		暗绿色	/	/	/	XF-1 20% + XF-5 80%
Clear blue	klar-Blau	透明蓝	H-93	C-50	/	X-23
Red Brown	Rotbraun	红棕色	H-47	C-41	160	XF-64

## READ BEFORE ASSEMBLING: VOR ZUSAMMENBAU LESEN: 组装必读:

- Carefully Study instruction before assembling. Anleitung studieren und verständlich machen. 组装前请阅读清楚制作指引。
- Keep plastic model glue and tools away from children. Kleber, Farben, Werkzeuge und Plastiktüten von Kindern fernhalten. 胶水,油漆及工具勿让小孩接触。
- Do not use cement or paint near open flame or sparks. Kleber/Farbe nicht in Nähe von offenen Flammen. 胶水及油漆勿接触火种。
- Do not work in closed room. Nur in ausreichend belüfteten Räumen arbeiten. 勿在密封地方制作模型。

# PARTS LIST 零件展示表:

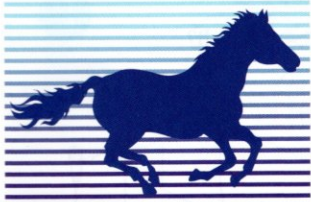

**BRONCO**

**Bronco Models**

Copyright © 2013

Made in China

中国制造

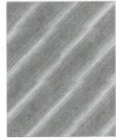

No use parts  
不要部件

ⓑ × 1

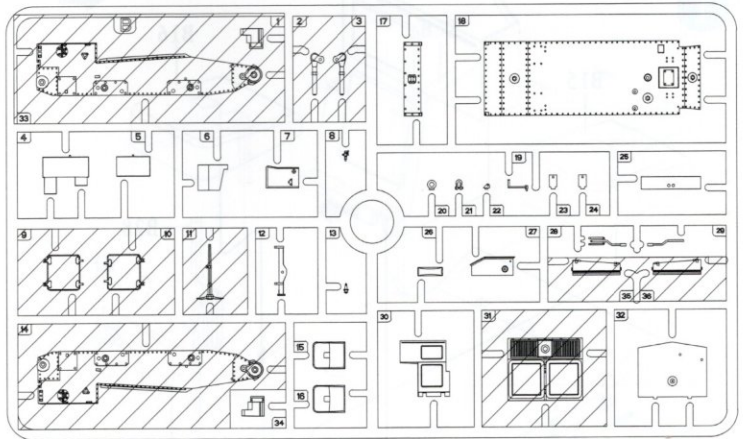

Ⓐ × 2

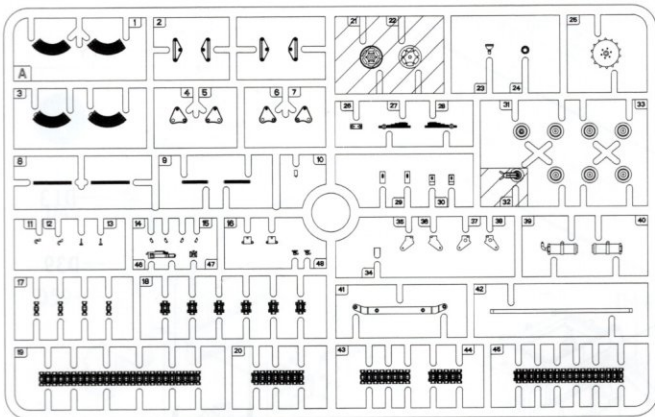

Ⓔ × 1

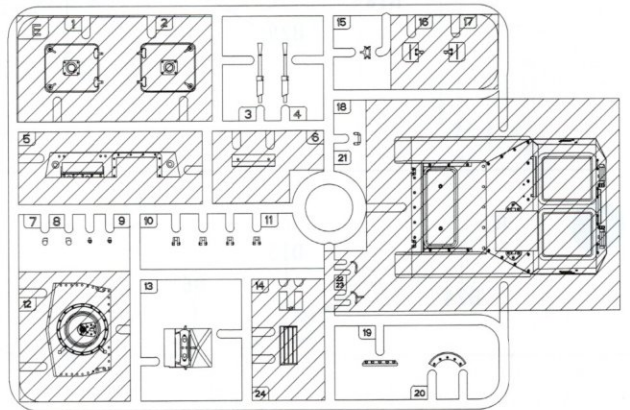

Ⓓ × 1

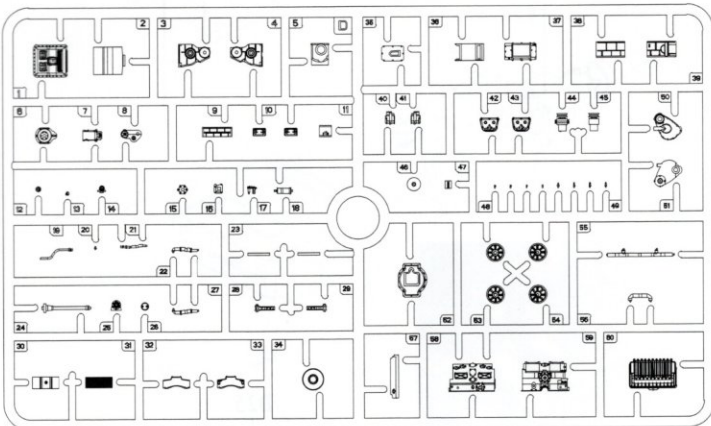

Ⓕ × 1

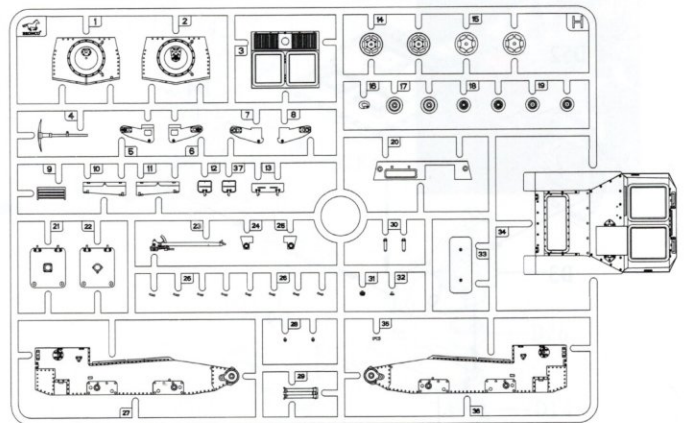

ⓒ × 1

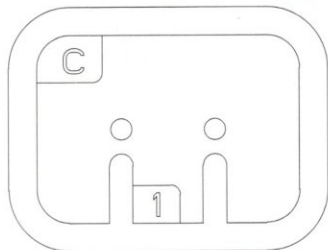

DECAL × 1

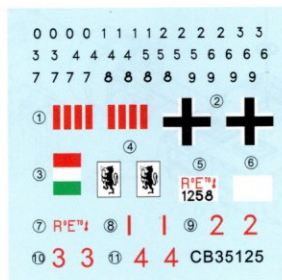

Ⓟ × 1

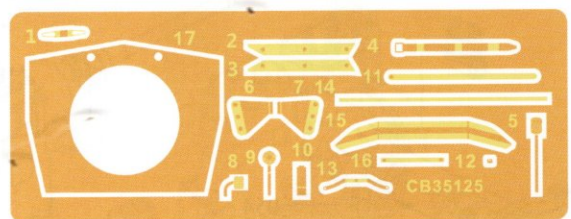

CB35125

# ILLUSTRATION 图示说明:

1

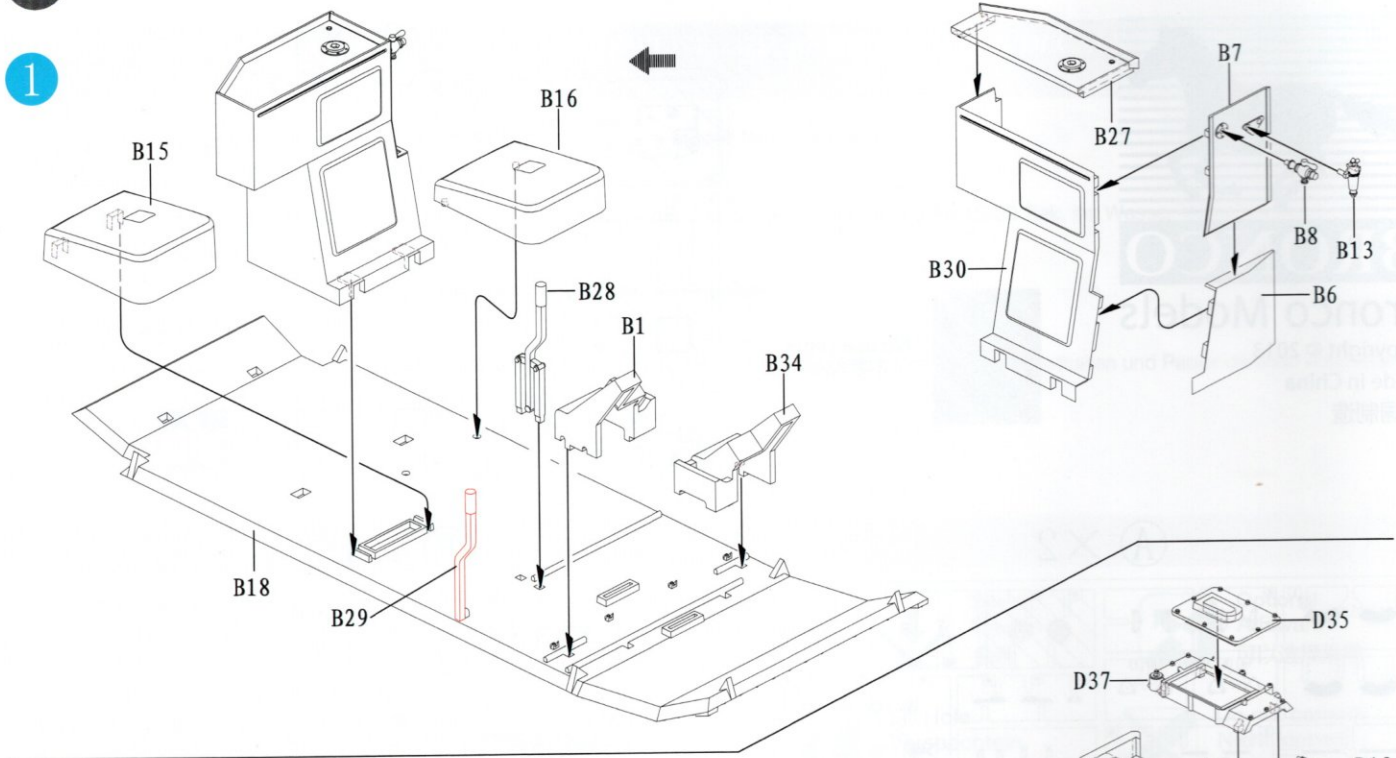

2

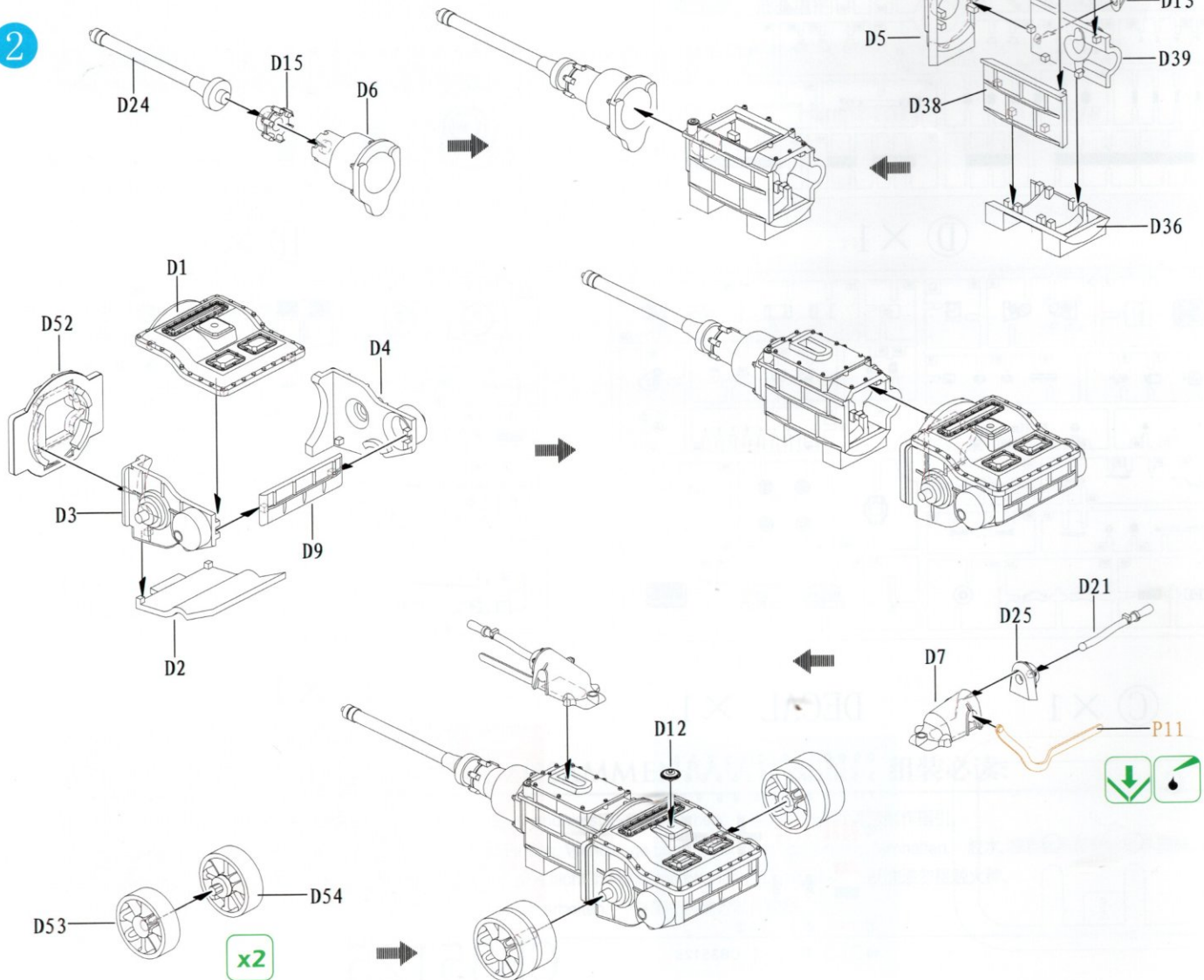

3

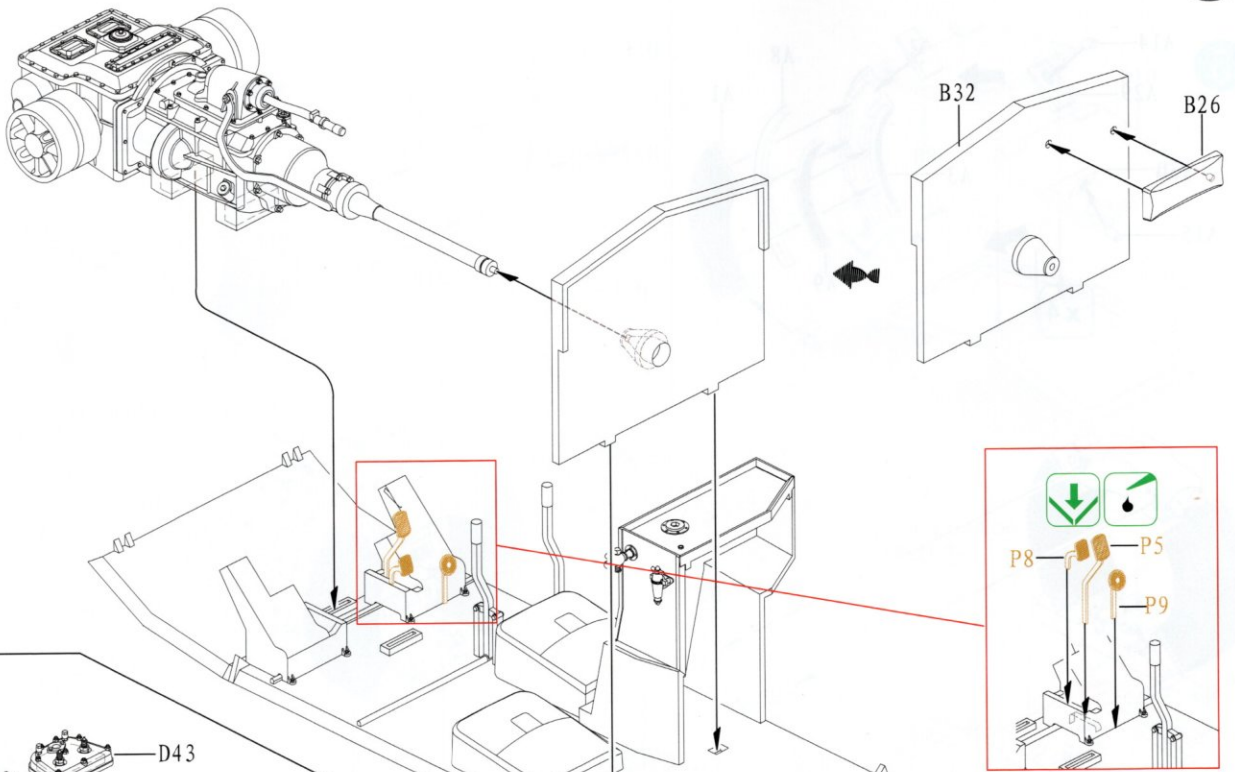

4

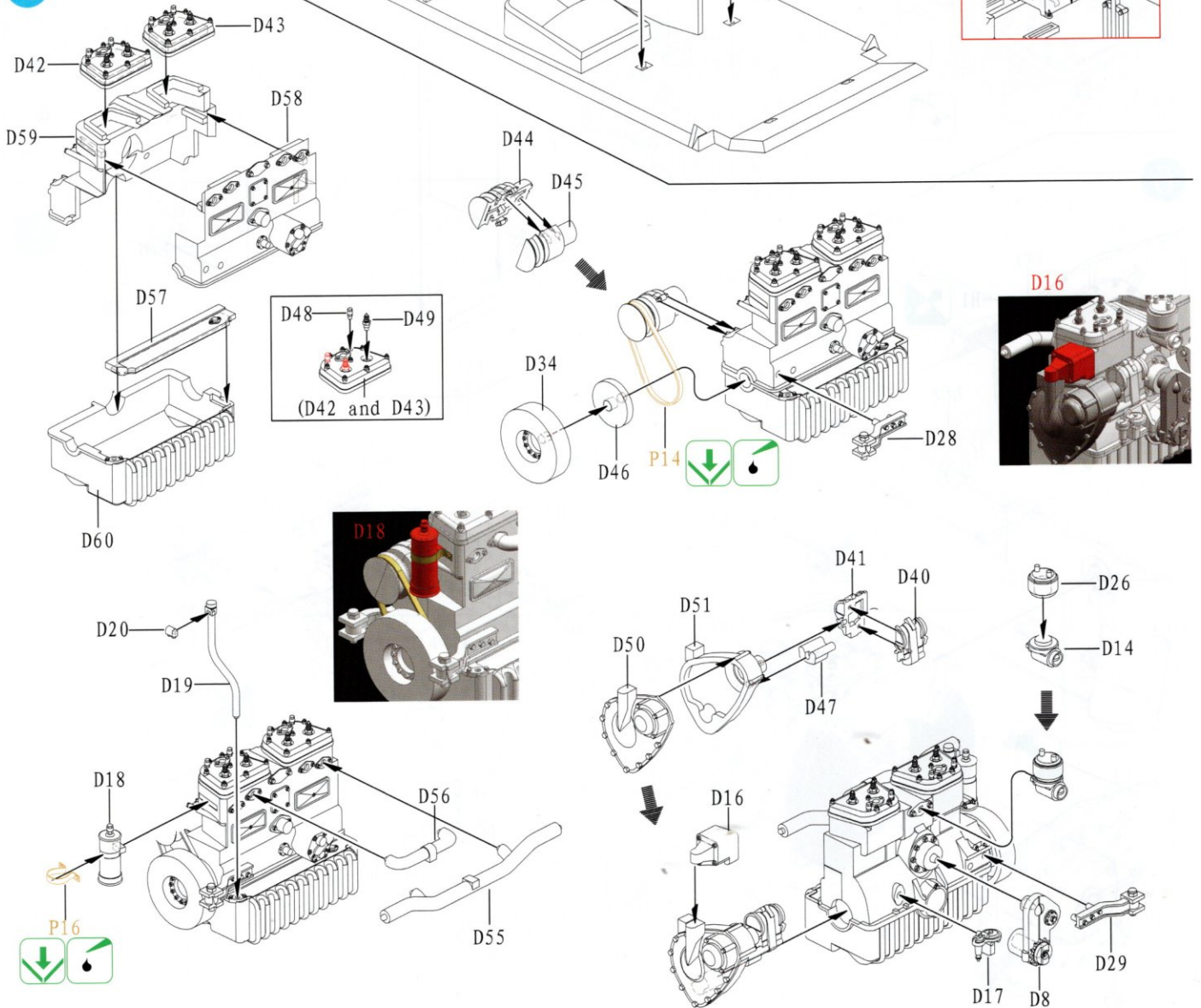

# ILLUSTRATION 图示说明:

5

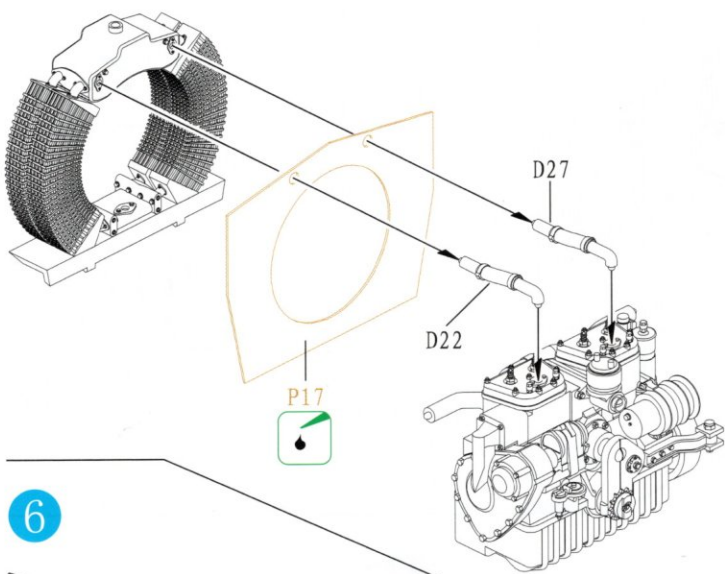
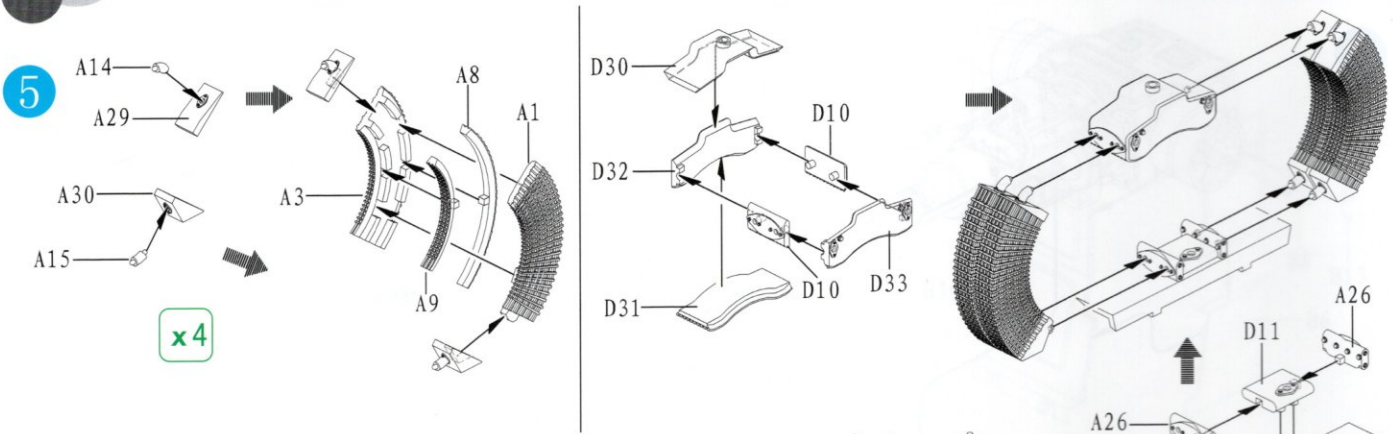

6

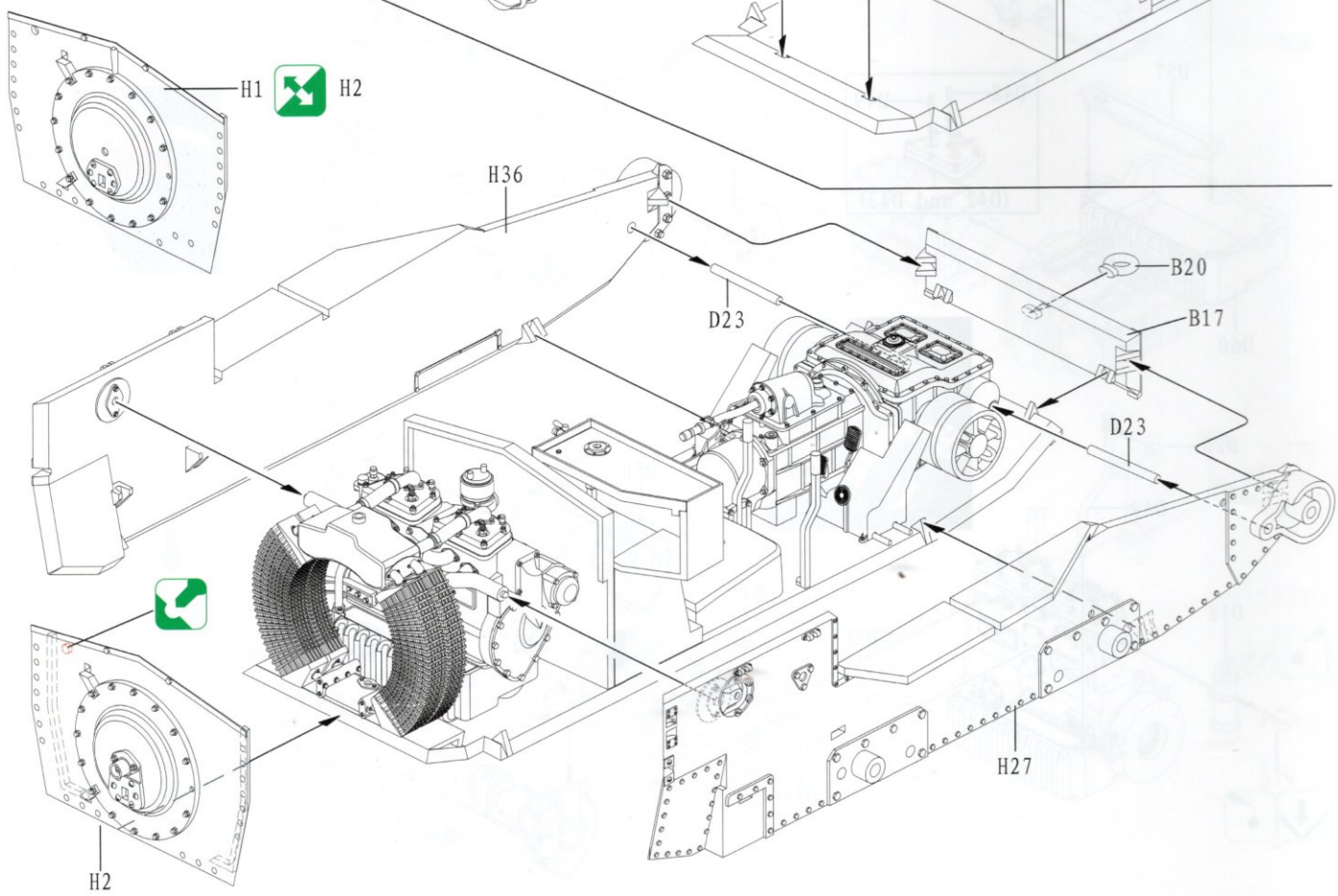

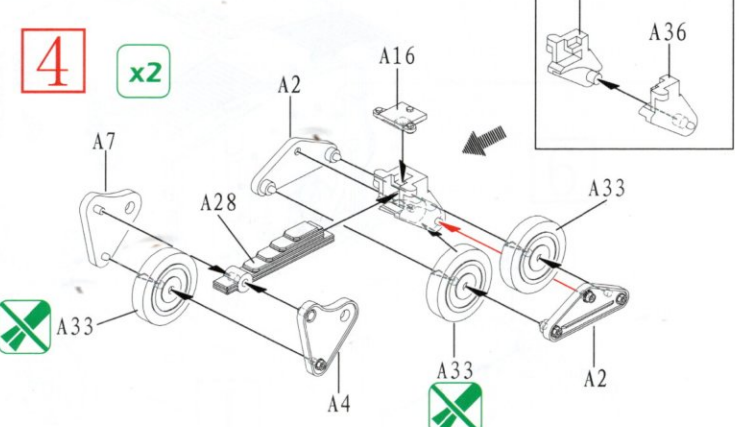
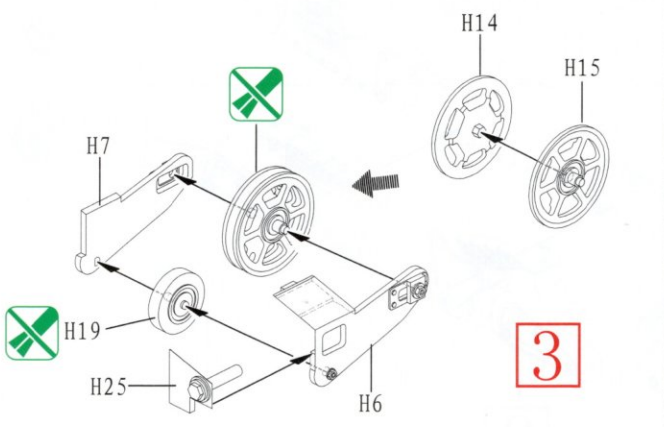
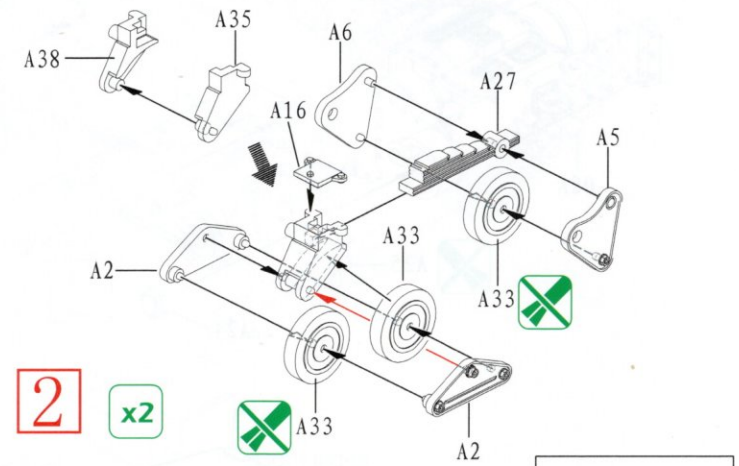
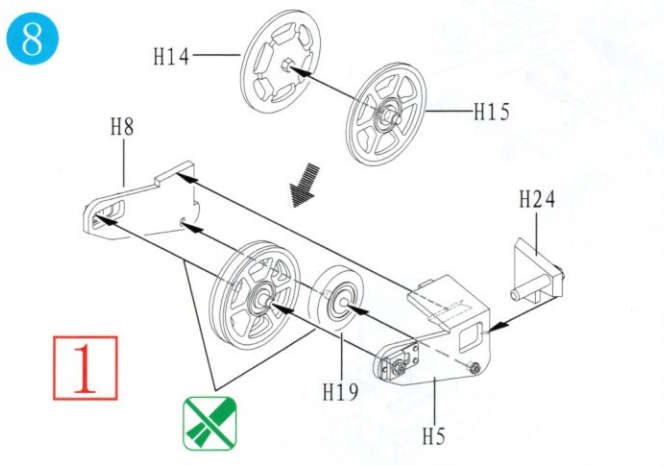
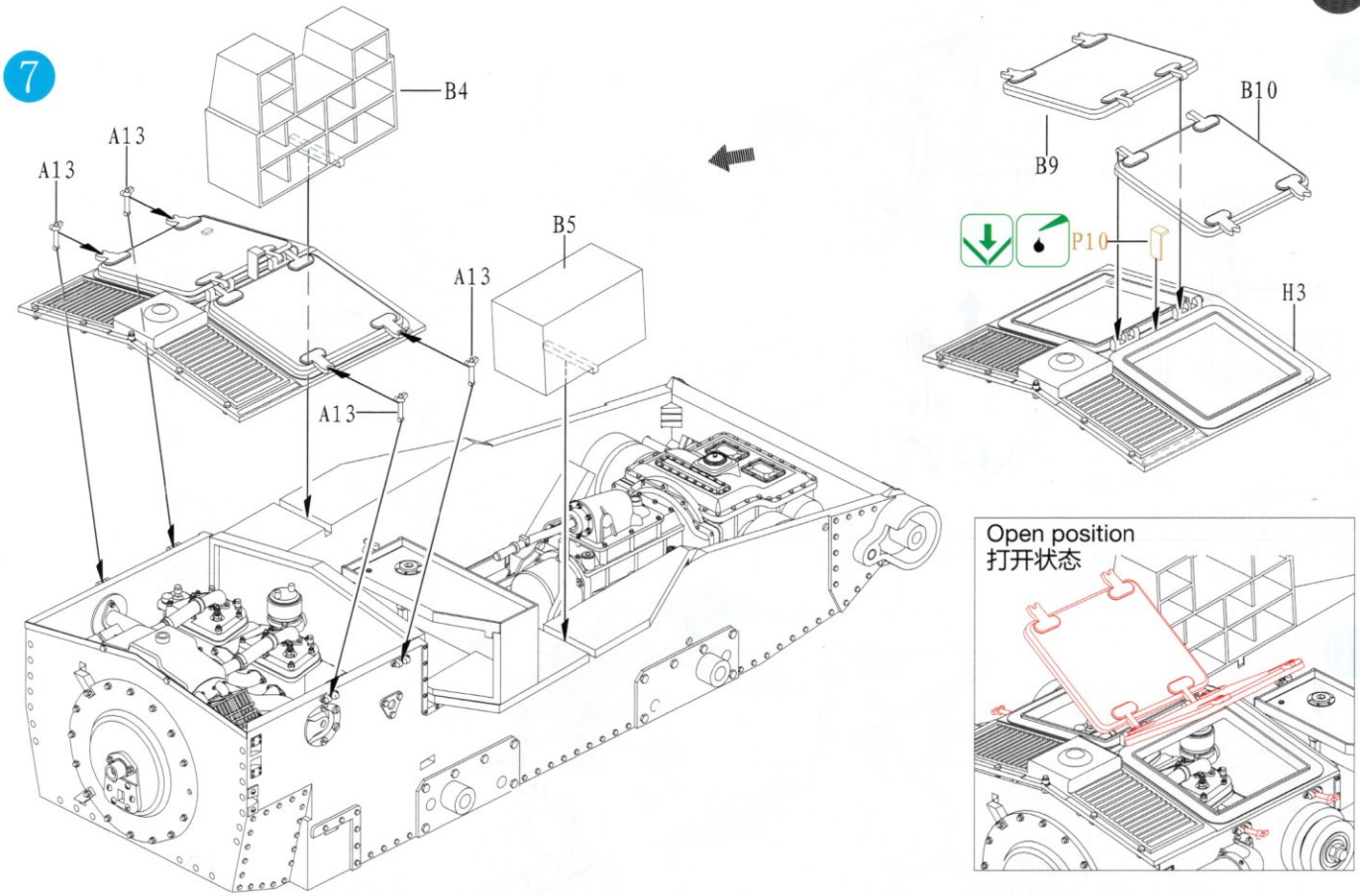

# ILLUSTRATION 图示说明:

9

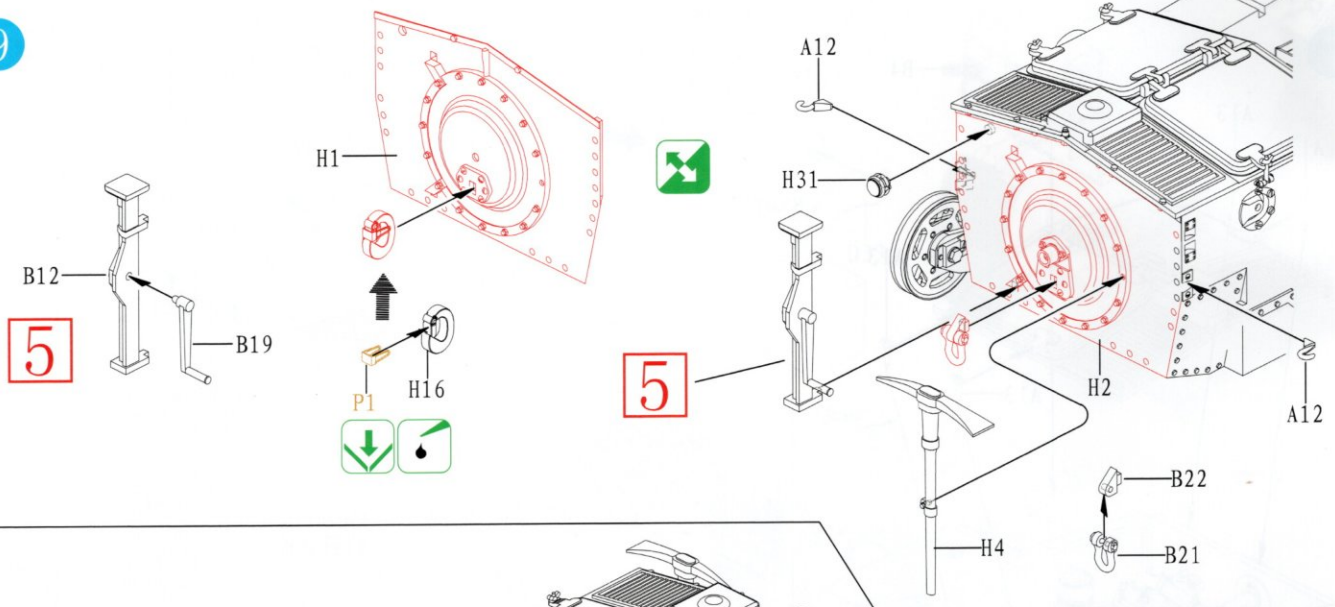

10

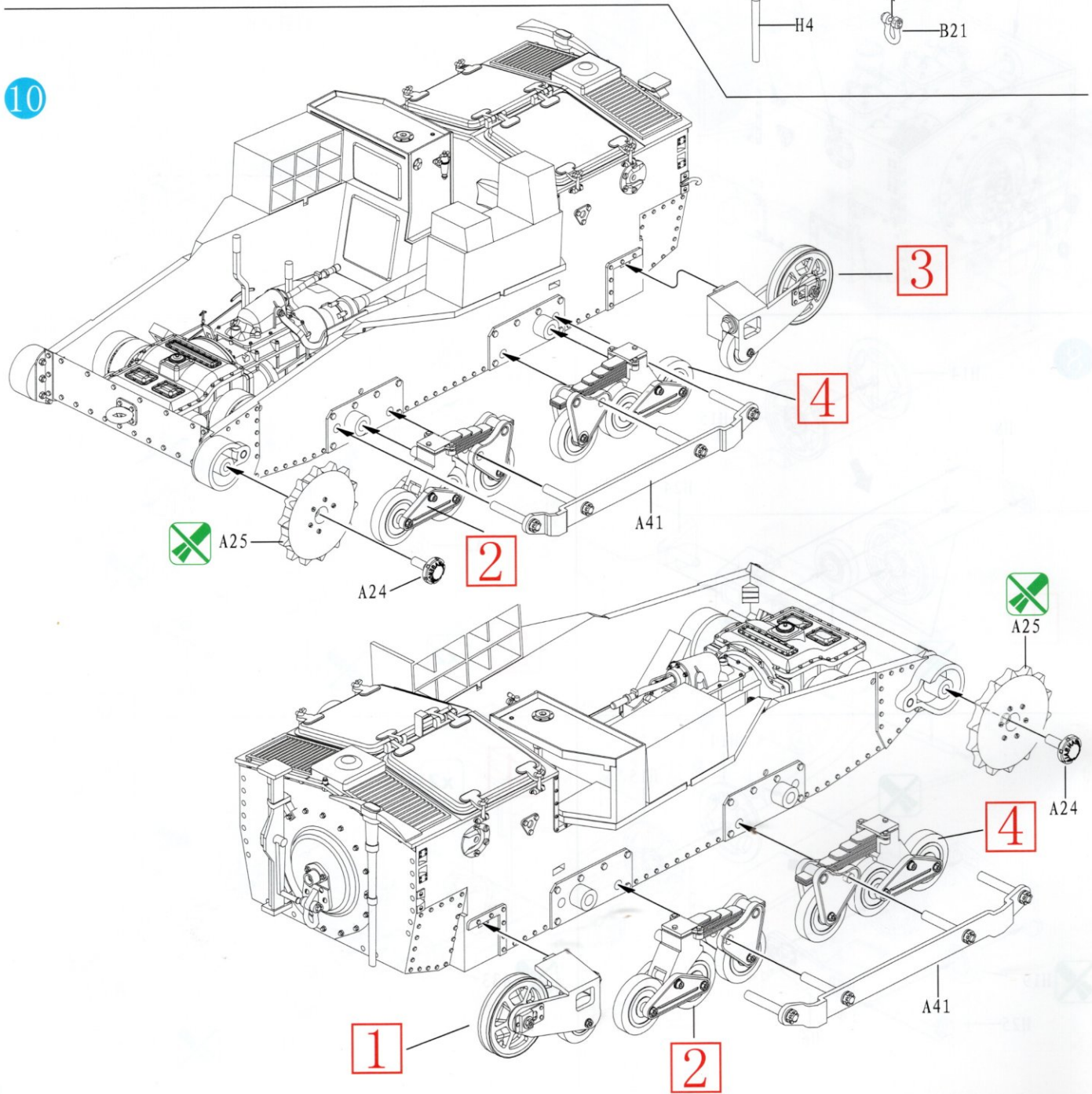



11

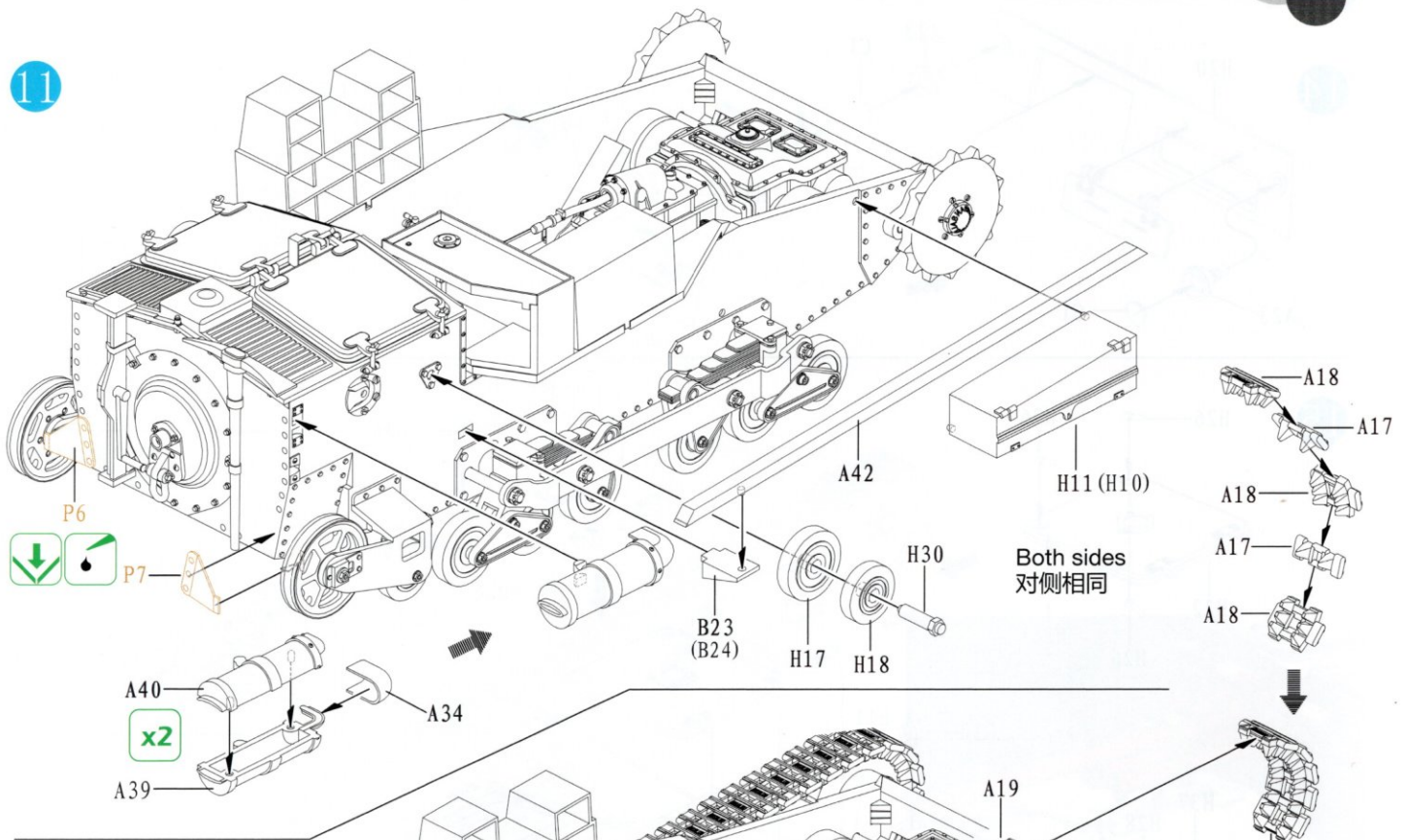

12

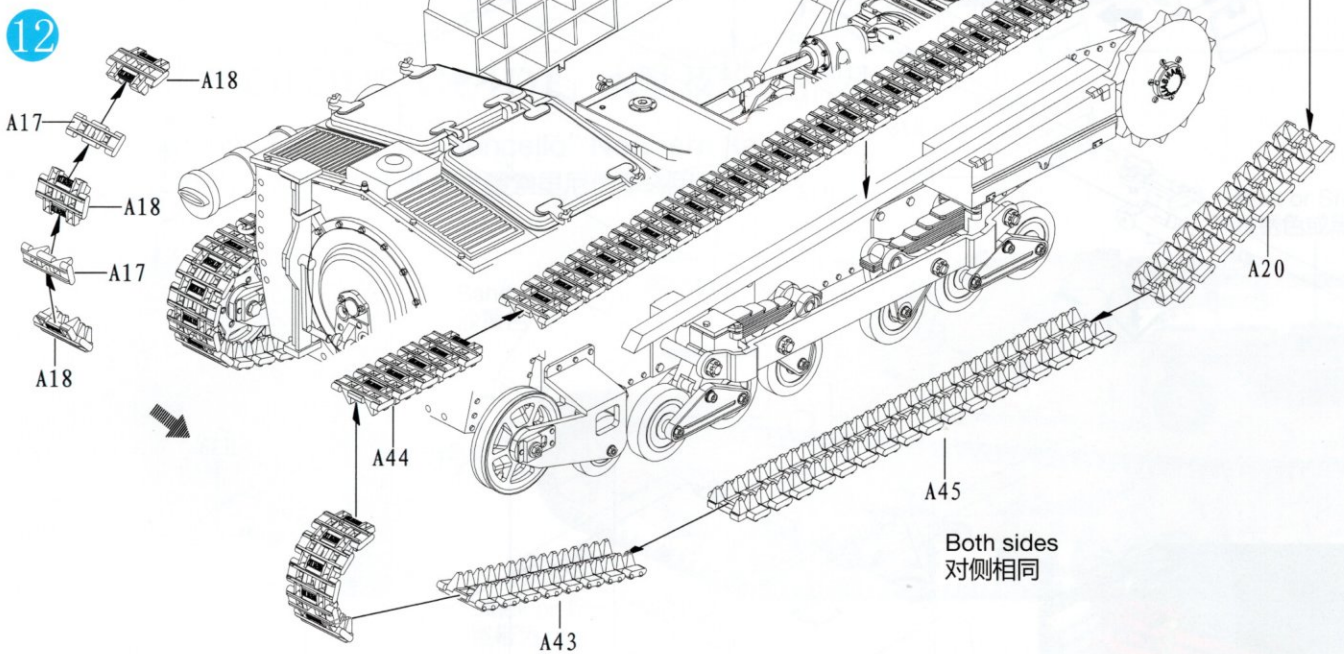

13

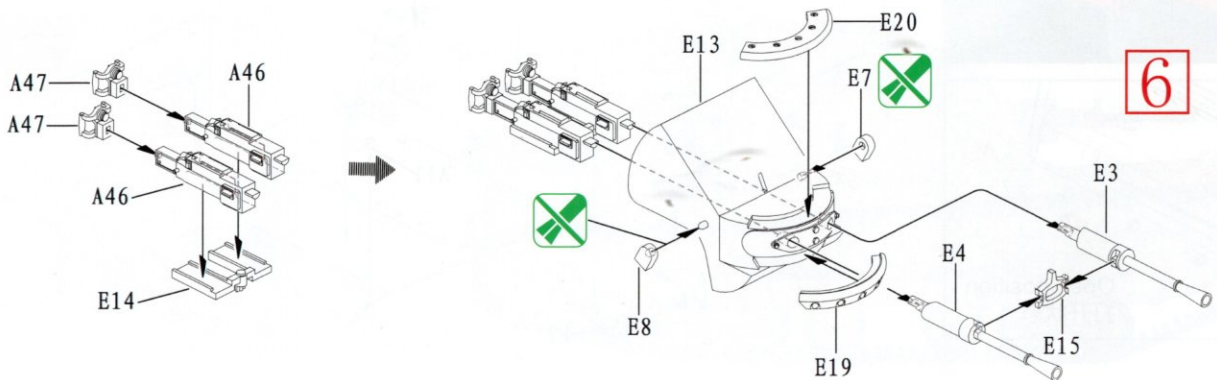

# ILLUSTRATION 图示说明:

14

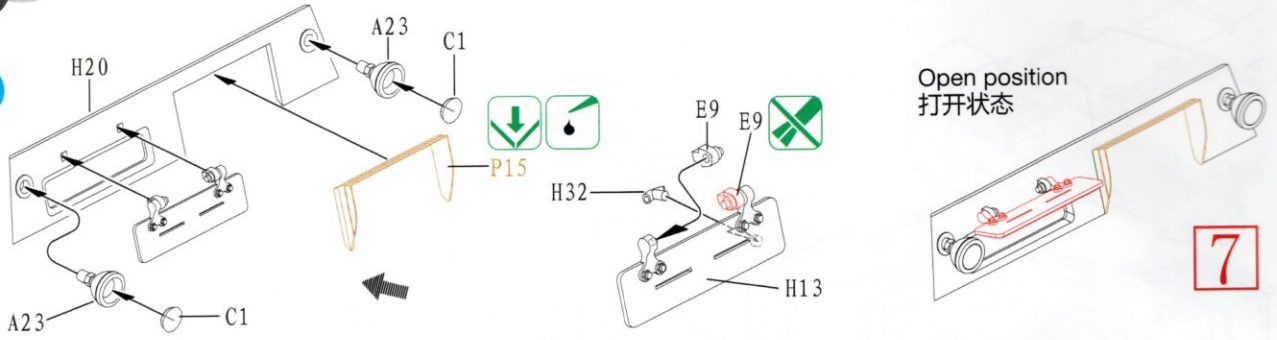

15

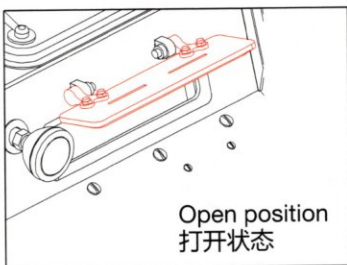
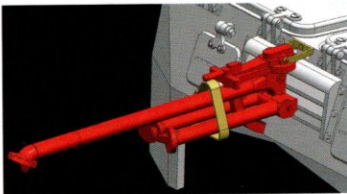
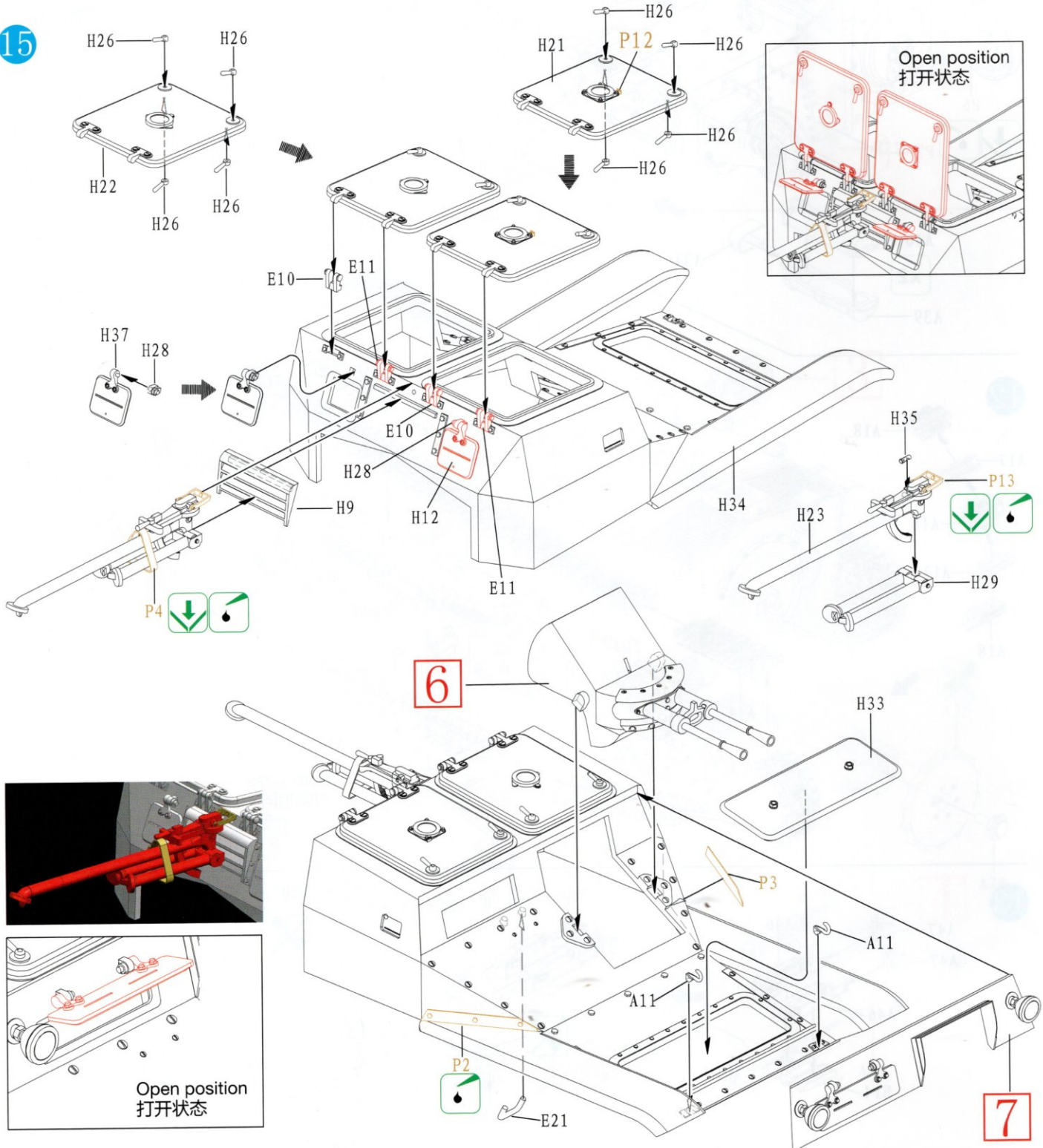

16

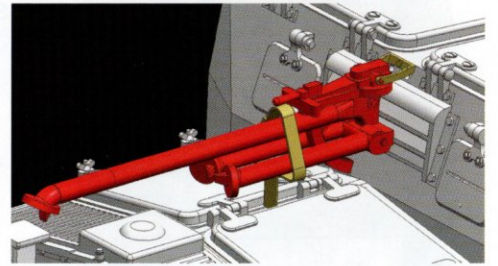
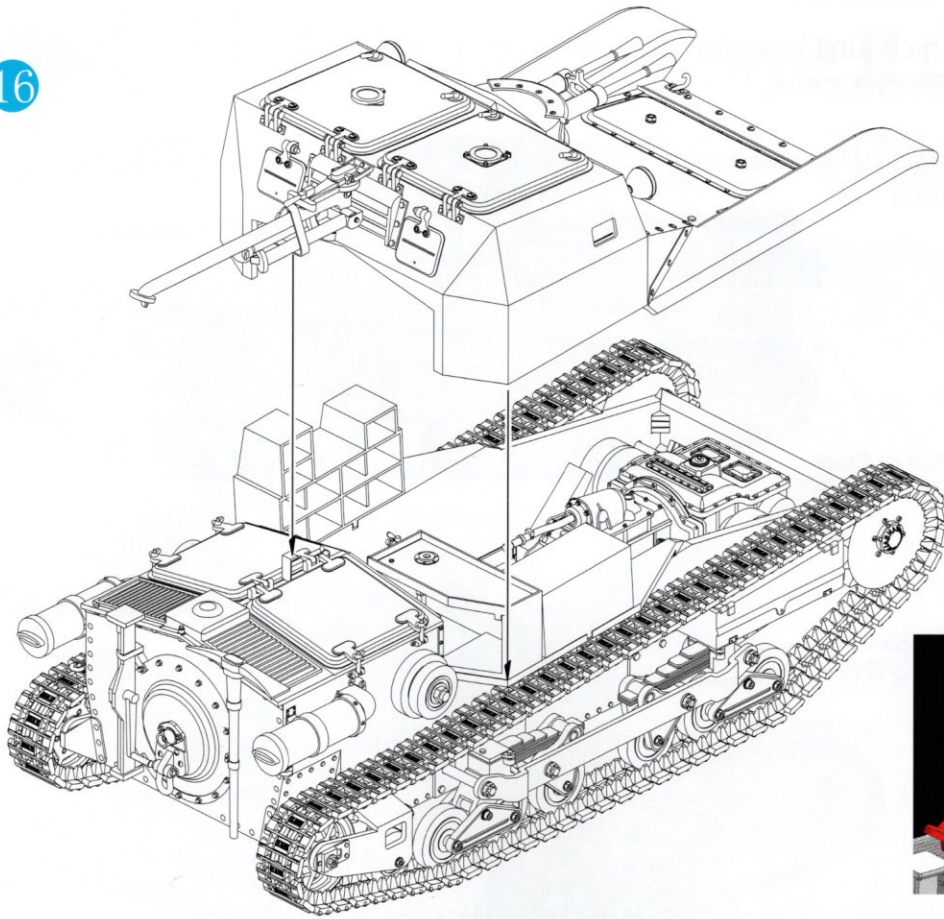

DECAL & COLOUR GUIDE 水贴及涂色指示:

Option 1: Gruppo Corazzata "Leoncello" Northern Italy, 1944.  
1944年控制着意大利北部之墨索里尼伪军装甲部队车辆。

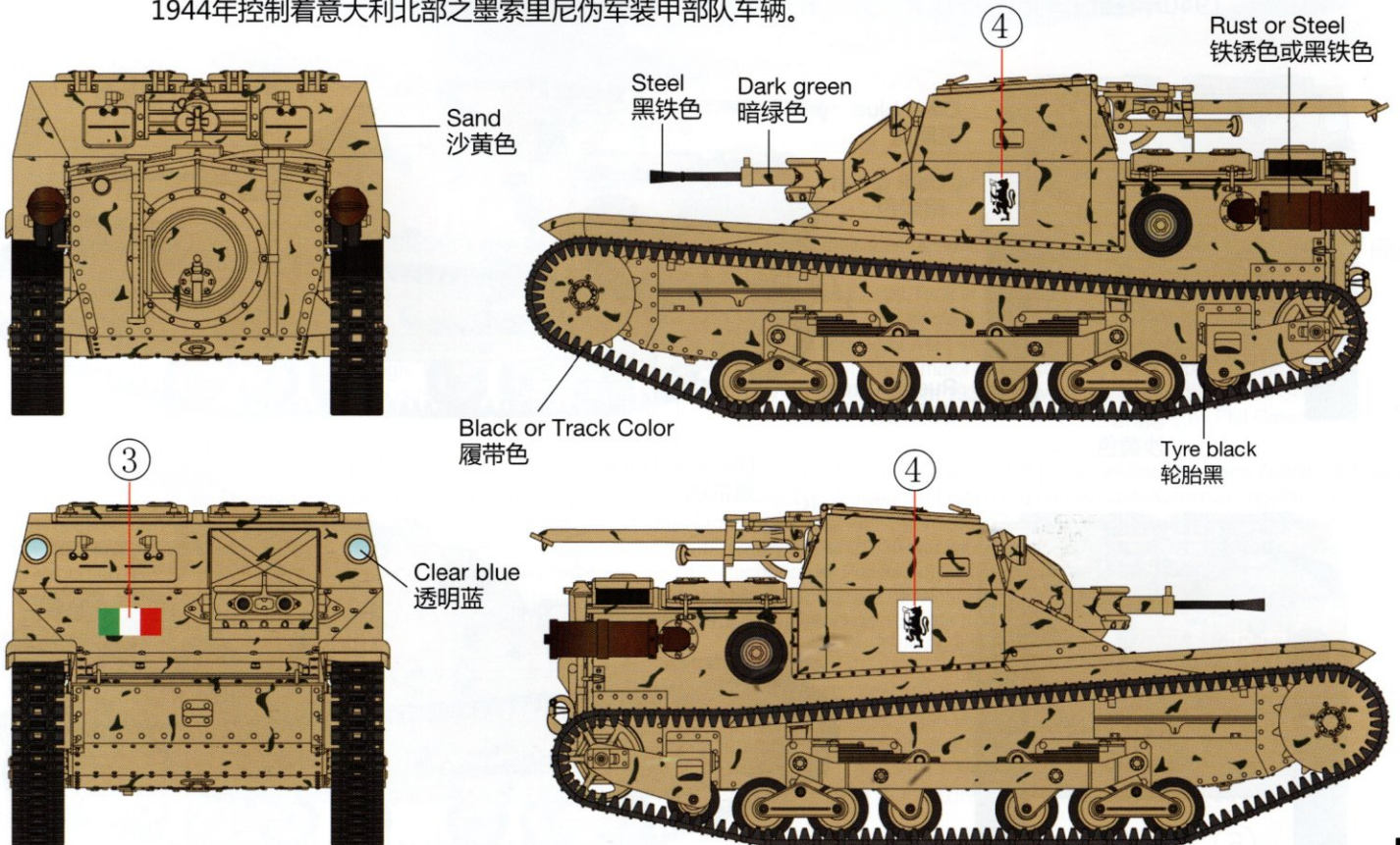

# DECAL & COLOUR GUIDE 水贴及涂色指示:

Option 2: German captured vehicle, unit unknown, Italy 1943.  
1943年间在意大利境内德军缴获之车辆。

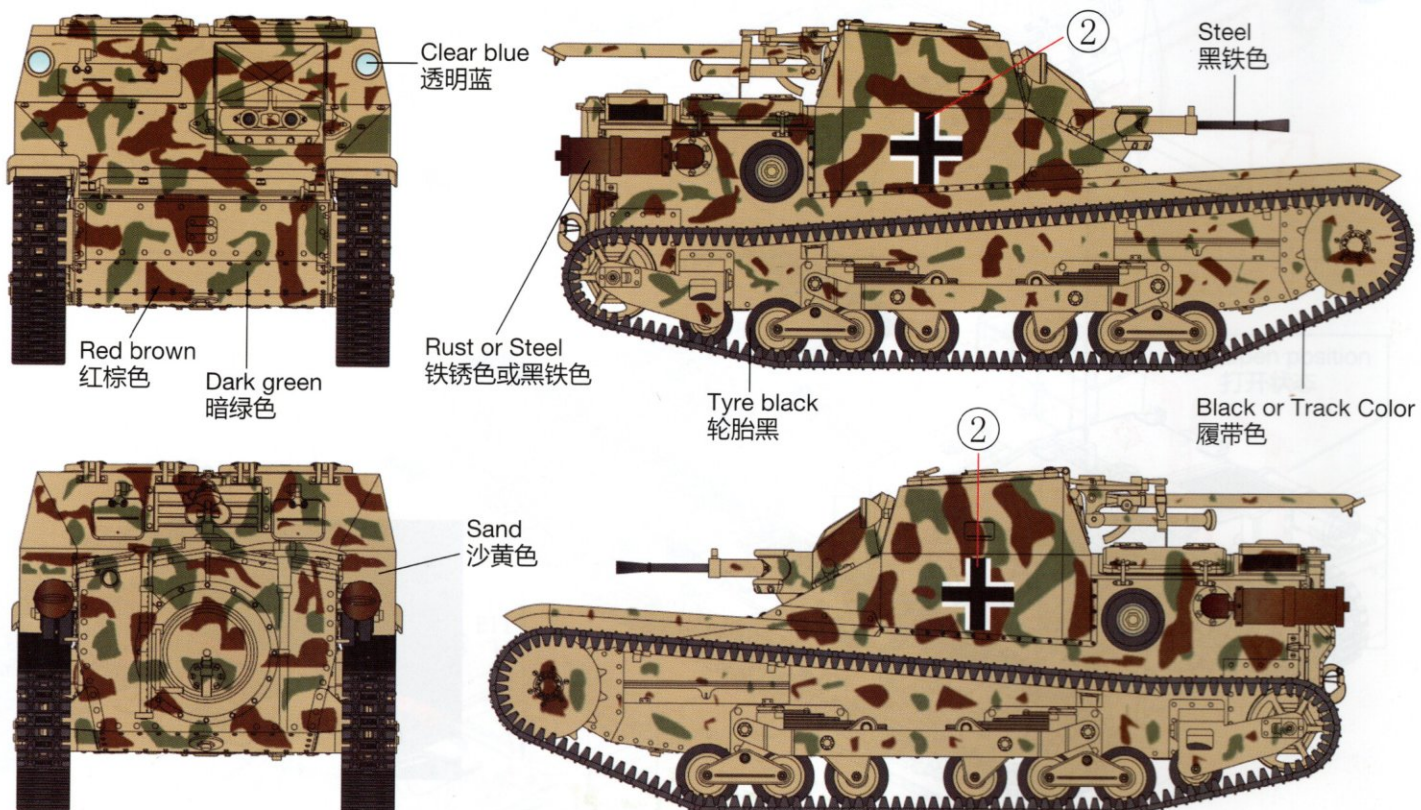

Option 3: The Special Armoured Brigade of the XXIIIrd Corps, 5th Army, Libya, 1940.  
1940年在北非利比亚作战之意大利第五军团第23兵团之特别装甲旅属下车辆。

