

MONOGRAM

KIT5611

85561110200

EA-6B PROWLER

Developed from the highly successful A-6 Intruder two-place attack aircraft, the four-seat Grumman EA-6B Prowler first saw combat in Vietnam during the early 1970s. It carried powerful and sophisticated electronic jamming* equipment intended to blind and confuse enemy radars that searched for and tracked U.S. aircraft for deadly surface-to-air missiles (SAMs). The Prowler quickly proved to be the best aircraft in the world at performing this dangerous but crucial mission. The crew of four consisted of a pilot in the left front seat and three electronic counter-measure officers (ECMOs) in the other three seats. The ECMOs operated the jamming equipment over a wide spectrum of the frequency bands used by enemy radars. Flown by both Navy and Marine squadrons from aircraft carriers and land bases, Prowlers have continued to protect American and allied aircraft in every combat operation since the war in Vietnam. Most recently, Prowlers flew

numerous missions during operation Iraqi Freedom. Today, two Navy squadrons are specifically designated to protect U.S. Air Force aircraft. Over the more than thirty years in which the Prowler has been in service, it has been continually upgraded to defeat new threats, and in addition to jamming enemy radars, it has also employed anti-radiation missiles that home in on the radars and destroy them. The Prowler remains in service to this day, but a replacement is scheduled to take its place in the next few years. When it is finally retired, the EA-6B will gain the distinction of being the last Grumman-built aircraft in service, thus closing out a long and proud tradition in Naval aviation. Your Revell kit comes with the colorful markings of an EA-6B assigned to VAQ-131 when that squadron operated aboard the USS AMERICA, CV-66



* REPEAT SEVERAL TIMES
* A REPETER PLUSIEURS FOIS



* OPTIONAL PARTS
* PIECES EN OPTION



* DECAL
* DECAL COMANIE



* ALTERNATIVE ASSEMBLY
* ENSEMBLAGE ALTERNATIVE



* CEMENT TOGETHER
* A COLLER



* REMOVE AND THROW AWAY
* A RETIRER ET JETER



* DO NOT CEMENT
* NE PAS COLLER

READ THIS BEFORE YOU BEGIN

- * Study the assembly drawings.
- * Each plastic part is identified by a number.
- * In the assembly drawings, some parts will be marked by a star (★) to indicate chrome plated plastic.
- * For better paint and decal adhesion, wash the plastic parts in a mild detergent solution. Rinse and let air dry.
- * Check the fit of each piece before cementing in place.
- * Use only cement for polystyrene plastic.
- * Scrape plating and paint from areas to be cemented.
- * Allow paint to dry thoroughly before handling parts.
- * Any unused parts may be discarded.

DECAL APPLICATION INSTRUCTIONS

1. Cut desired decal from sheet.
2. Dip decal in water for a few seconds.
3. Place wet decal on paper towel.
4. Wait until decal is movable on paper backing.
5. Place decal in position on model, face up and slide backing away.
6. Press out air bubbles with a soft damp cloth.
7. Milkyness that may appear is for better decal adhesion and will dry clear. Wipe away any excess adhesive.
8. Do not touch decal until fully dry.
9. Allow the decals 48 hours to dry before applying clear coat.

NOTE: Decals are compatible with setting solutions or solvents.

LIRE CE QUI SUIT AVANT DE COMMENCER

- * Etudier les schémas de montage.
- * Chaque pièce en plastique est identifiée par un numéro.
- * Sur les schémas de montage, certaines pièces sont marquées d'une étoile (★) pour indiquer qu'elles sont en plastique chromé.
- * Pour une meilleure prise de la peinture et des autocollants, laver les pièces en plastique avec une solution détergente peu concentrée. Les rincer et les laisser sécher à l'air.
- * Vérifier que chaque pièce s'ajuste bien avant de la coller en place.
- * N'utiliser que de la colle pour polystyrène.
- * Gratter les parties à coller pour enlever le chrome et la peinture.
- * Laisser la peinture bien sécher avant de manipuler les pièces.
- * Toute pièce inutilisée peut être jetée.

DIRECTIVES D'APPLICATION DES AUTOCOLLANTS

1. Découper l'autocollant désiré de la feuille.
2. Tremper l'autocollant dans de l'eau pendant quelques secondes.
3. Placer l'autocollant mouillé sur une serviette en papier.
4. Attendez que l'autocollant puisse être déplacé sur son support en papier.
5. Mettre l'autocollant en position sur le modèle face sur le dessus et faire glisser le support pour l'enlever.
6. Appuyer avec un chiffon doux humide pour éliminer les bulles d'air.
7. La substance laiteuse qui peut apparaître est destinée à améliorer l'adhésion de l'autocollant et devient incolore au séchage. Essuyer pour enlever tout excédent d'adhésif.
8. Ne pas toucher l'autocollant tant qu'il n'est pas bien sec.
9. Laisser l'autocollant sécher pendant 48 heures avant d'appliquer une couche transparente.

REMARQUE: Les autocollants sont compatibles avec les solutions de fixation ou les solvants.

This optional paint guide is provided if you choose to detail paint your model.

Ce guide de peinture vous sera fourni si vous choisissez de peindre votre modèle en détail.

Dark Green		Vert foncé
Flat Black	FS 17038	Noir mat
Flat Dk. Gull Gray	FS 36231	Gris cendré foncé mat
Flat Tan	FS 33613	Havane mat
Gloss Black	FS 17038	Noir brillant
Gloss Lt. Gull Gray	FS 16440	Gris cendré clair brillant
Gloss Yellow	FS 13538	Jaune brillant
Gloss White	FS 17875	Blanc brillant
Green		Vert
Light Gray	FS 16473	Gris clair
Medium Blue	FS 15180	Bleu moyen
Olive Drab	FS 34078	Gris vert
Olive Green		Olivet
Red		Rouge
Silver		Argent
Steel		Acier

If you have any questions or comments, call our hotline at: **(800) 833-3570** or, please write to:

Revell-Monogram Consumer Service Department, 8601 Waukegan Road, Morton Grove, Illinois 60053
Be sure to include the plan number (85561100200), part number, description, your return address and phone number.

Visit our website: www.revell-monogram.com

COCKPIT ASSEMBLY

140 FRONT BULKHEAD
DARK GULL GRAY

141 REAR BULKHEAD
DARK GULL GRAY

39 INTERIOR BUCKET
DARK GULL GRAY WITH FLAT BLACK CONSOLES, SILVER SWITCHES

PAINT SEAT CUSHION (SURVIVAL PACKS) OLIVE DRAB WITH LIGHT GRAY LAP BELTS AND SILVER BUCKLES (ALL FOUR SEATS)

139 FRONT INSTRUMENT PANEL
DARK GULL GRAY WITH BLACK PANELS, GRAY KNOBS AND SILVER SWITCHES

47 CONTROL STICK
DARK GULL GRAY (PAINT FLAT BLACK GRIP)

PAINT NOTE:
BLACK CONSOLE - WHITE DIALS

138 REAR INSTRUMENT PANEL
DARK GULL GRAY WITH FLAT BLACK PANELS, GRAY KNOBS AND SILVER SWITCHES

PILOT SEAT

45 SEAT TOP
FLAT BLACK (PAINT SHADED AREA YELLOW WITH BLACK STRIPES)

44 SEAT (RIGHT SIDE)
FLAT BLACK

LIGHT GRAY STRAPS

101 SEAT FRONT
OLIVE DRAB (PAINT SHADED AREA FLAT BLACK)

43 SEAT (LEFT SIDE)
FLAT BLACK

SILVER BUCKLES

3X ELECTRONIC WARFARE OFFICERS SEATS

45 SEAT TOP
FLAT BLACK (PAINT SHADED AREA YELLOW WITH BLACK STRIPES)

44 SEAT (RIGHT SIDE)
FLAT BLACK

LIGHT GRAY STRAPS

46 SEAT FRONT
OLIVE DRAB (PAINT SHADED AREA FLAT BLACK)

43 SEAT (LEFT SIDE)
FLAT BLACK

SILVER BUCKLES

3X 79 ELECTRONIC WARFARE OFFICER ARM

78 ELECTRONIC WARFARE OFFICER

77 PILOTS ARM

76 PILOT

?

PAINTING NOTE: FLIGHT SUITS AND GLOVES ARE OLIVE GREEN, BOOTS AND VISOR ARE BLACK. HELMETS ARE USUALLY WHITE, BUT CAN BE OF ANY COLOR

!

NOTE: IF YOU MUST OPEN UP SLOTS ON BOTH SIDES IN THIS STEP IF YOU DECIDE TO HAVE THE CANOPY OPEN. SEE STEP 5 FOR FURTHER DETAILS

2 RIGHT FUSELAGE HALF
(PAINT SHADED AREA DARK GULL GRAY (BOTH FUSELAGE HALVES))

COMPLETED INTERIOR ASSEMBLY

2

FUSELAGE AND WING ASSEMBLY

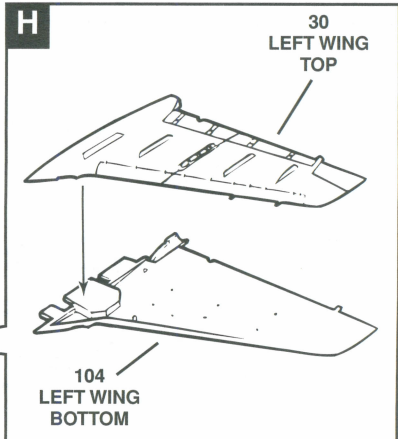
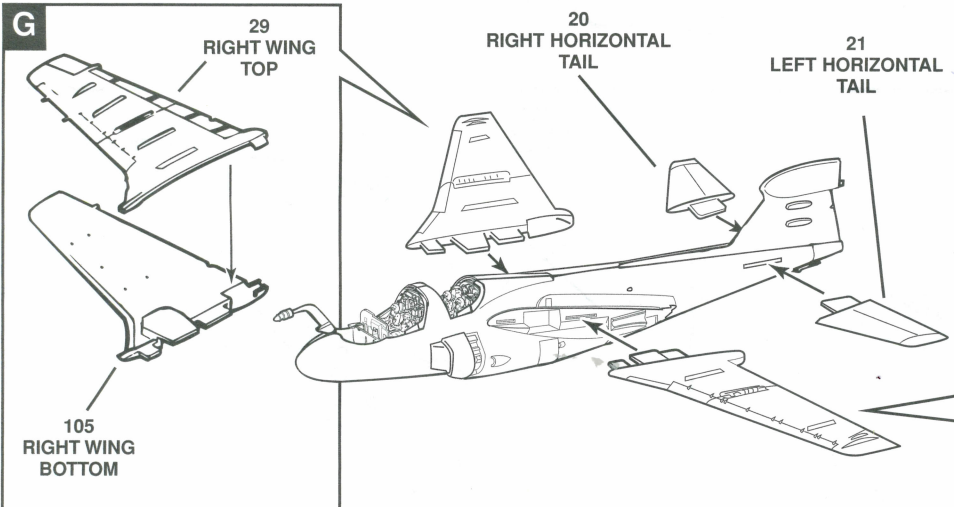
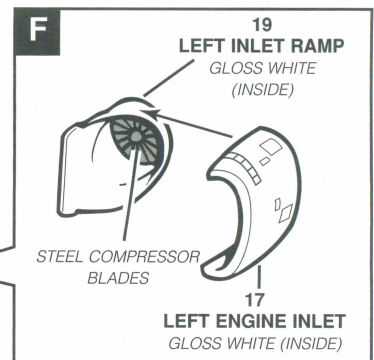
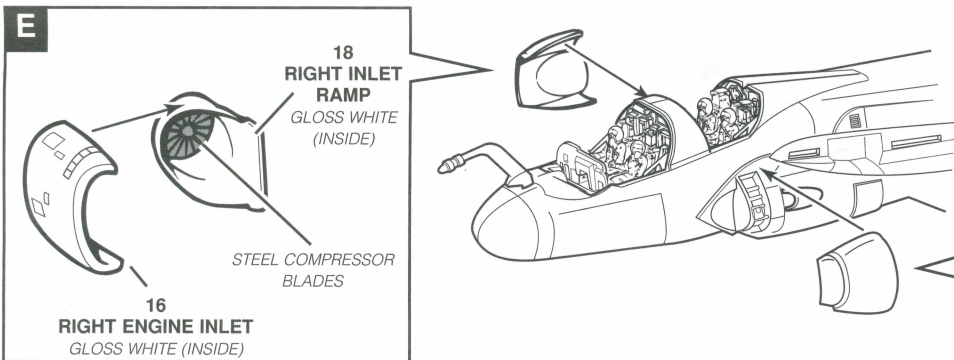
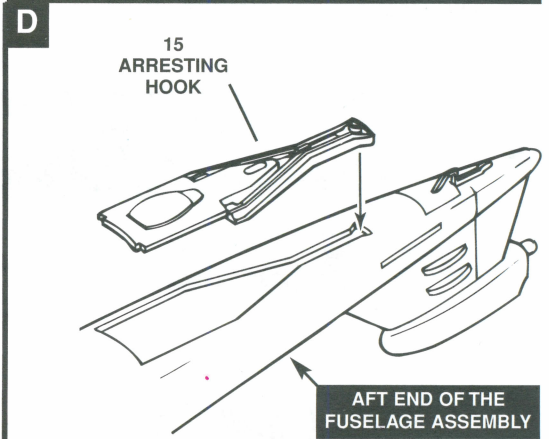
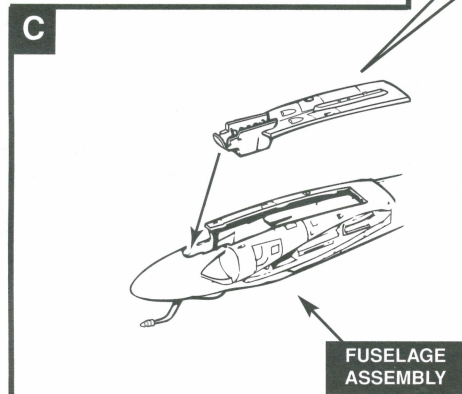
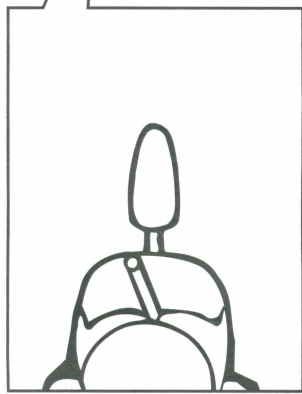
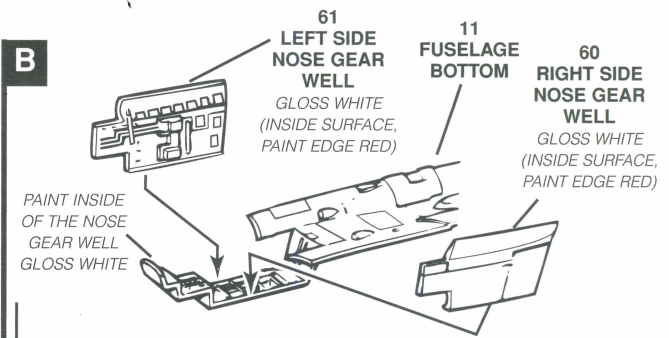
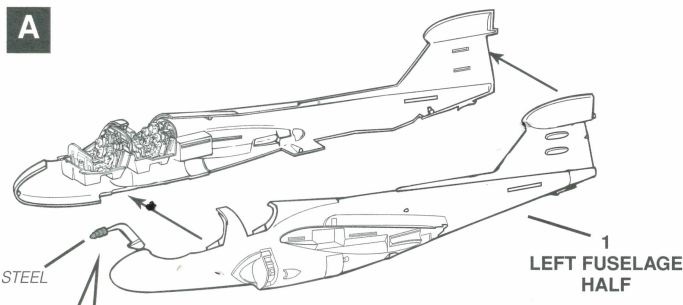

3

NOSE LANDING GEAR ASSEMBLY

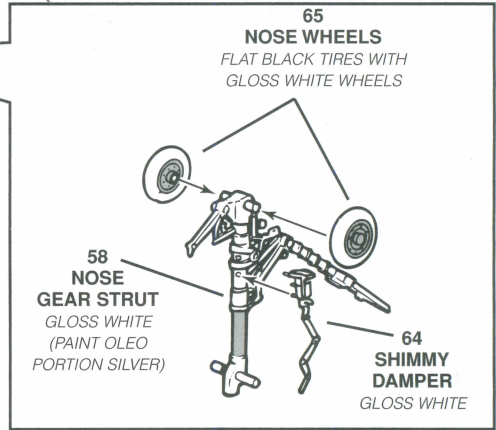
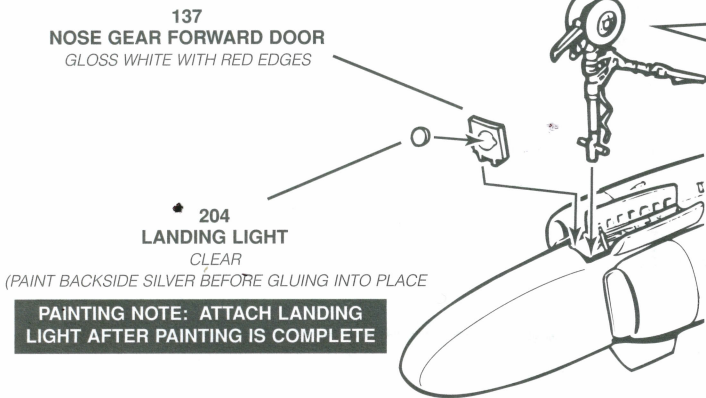

4

MAIN LANDING GEAR ASSEMBLY

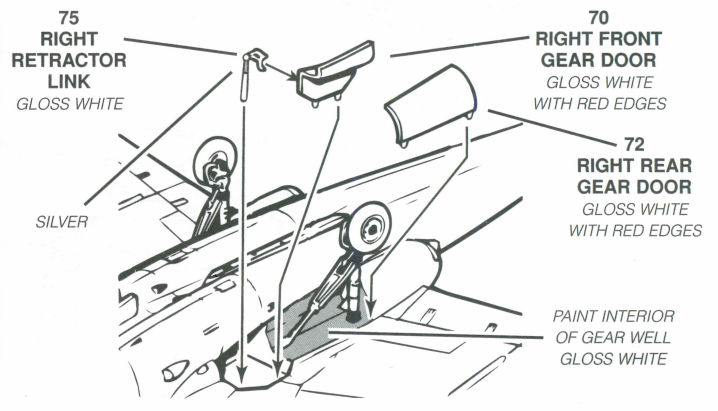
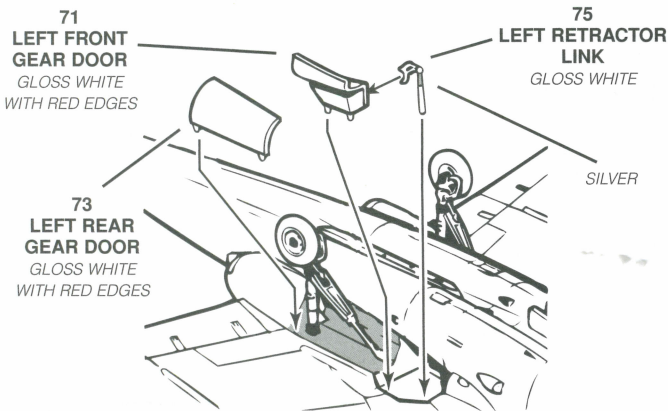
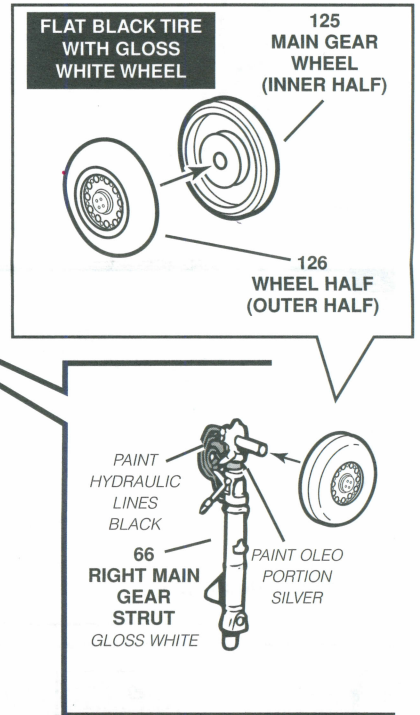
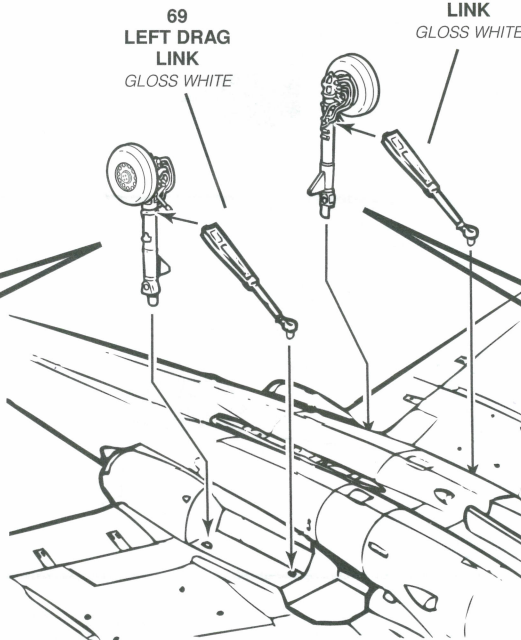
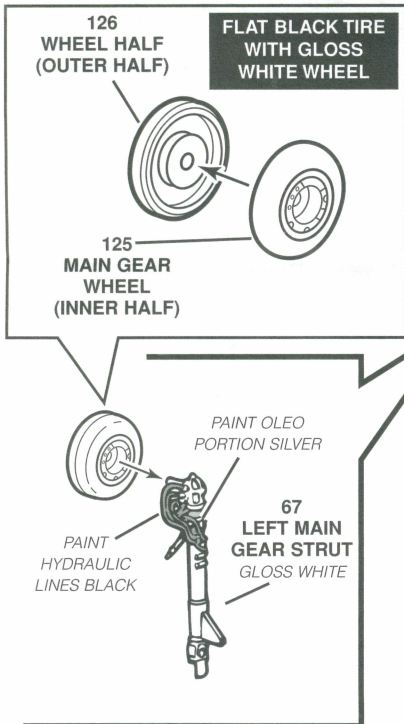

CANOPY ASSEMBLY

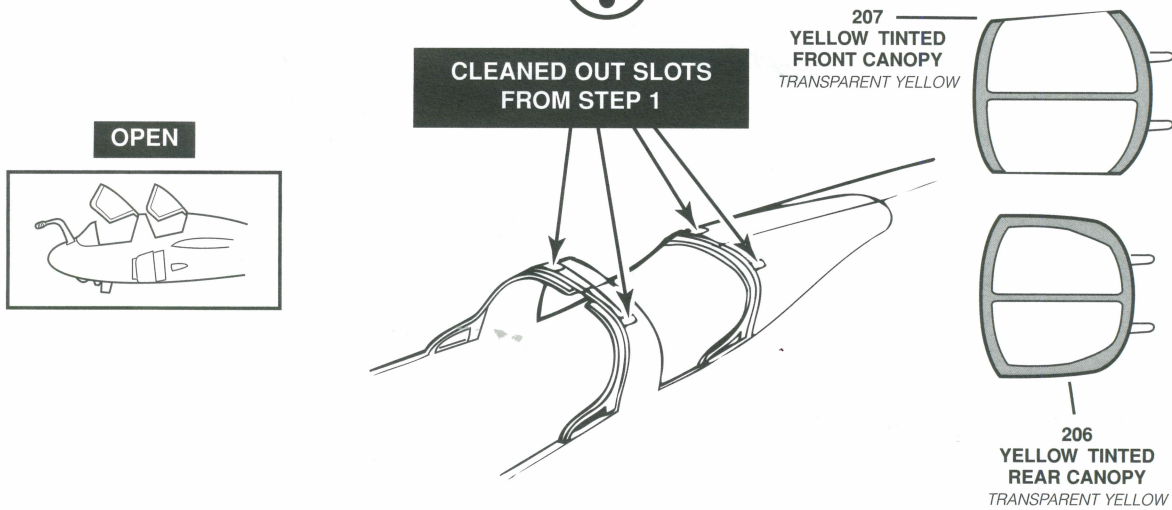
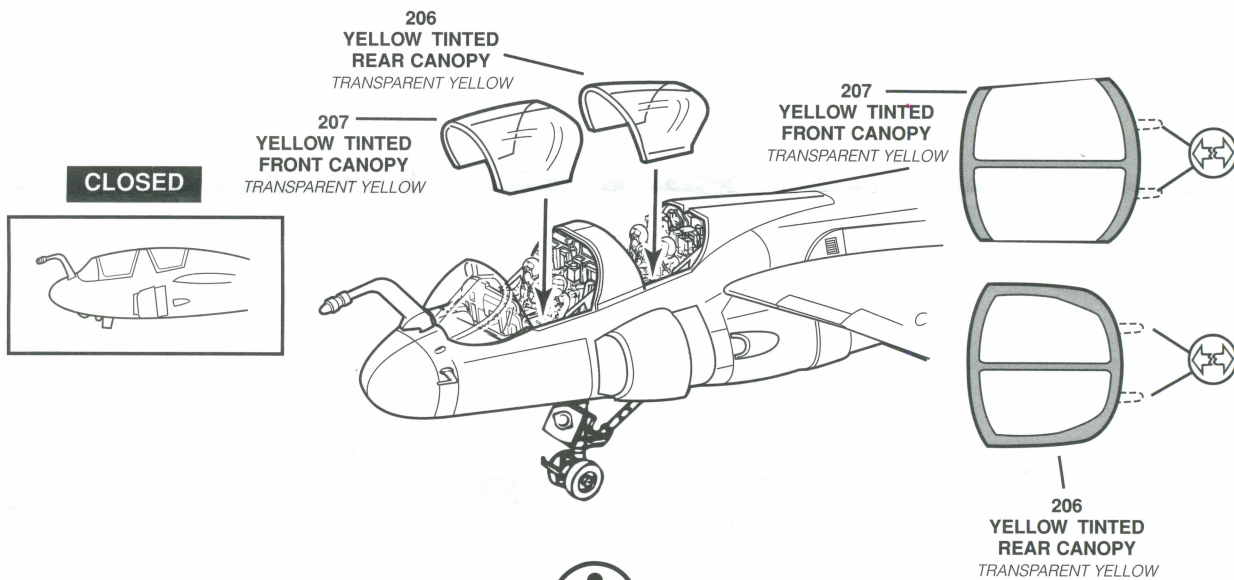
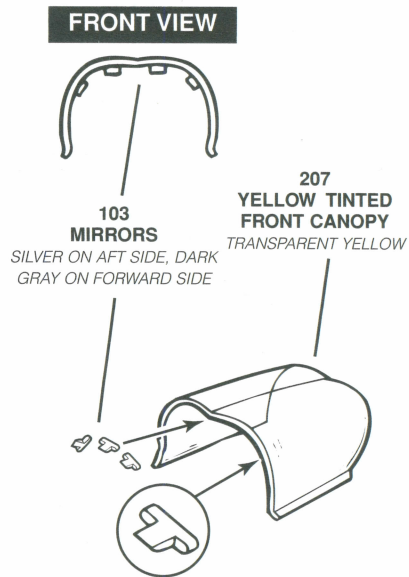
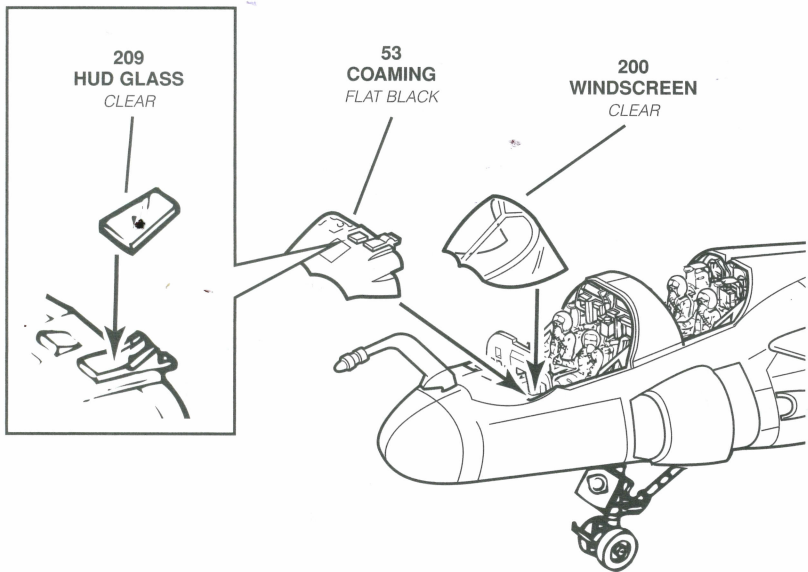

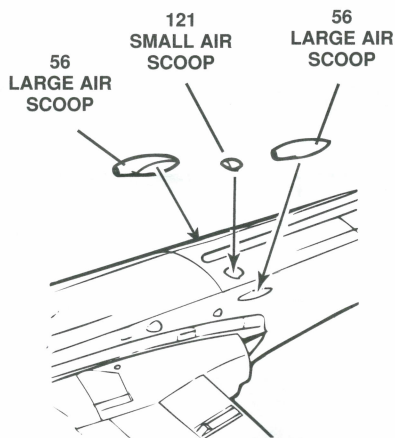
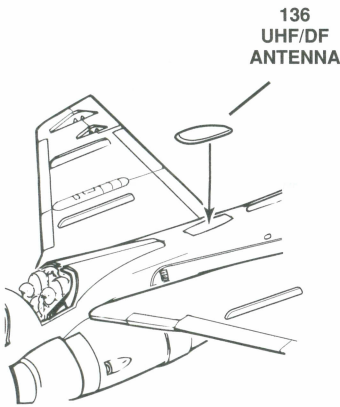
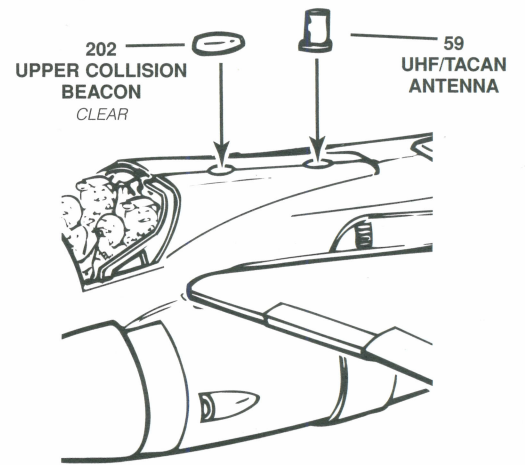
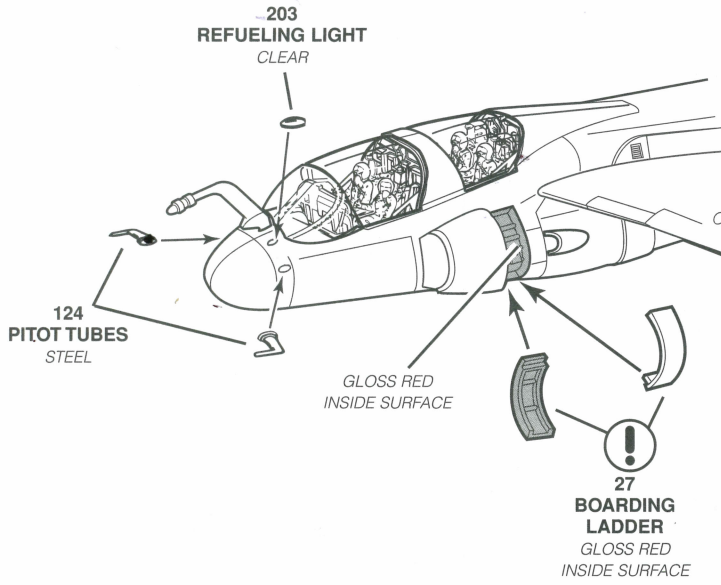

TOP OF FUSELAGE

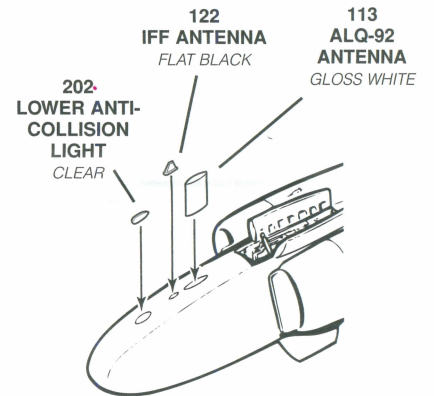

NOTE SOME PARTS OMITTED FOR CLARITY

FORWARD UNDERSIDE SECTION OF FUSELAGE

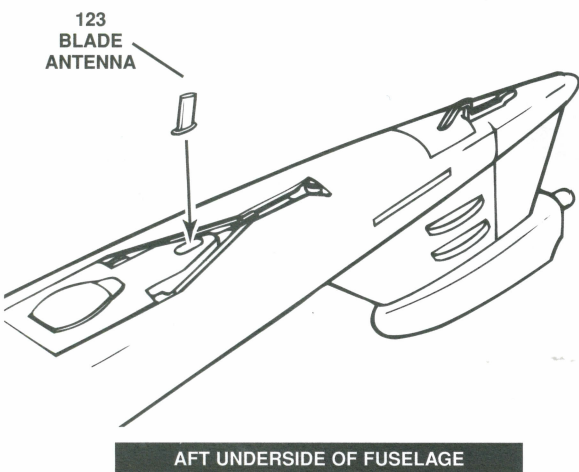

AFT UNDERSIDE OF FUSELAGE

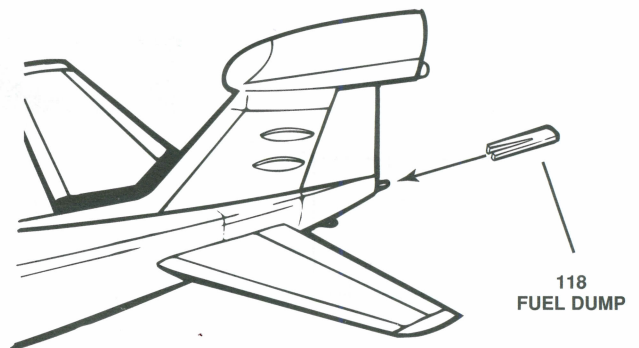

POD AND TANK ASSEMBLY

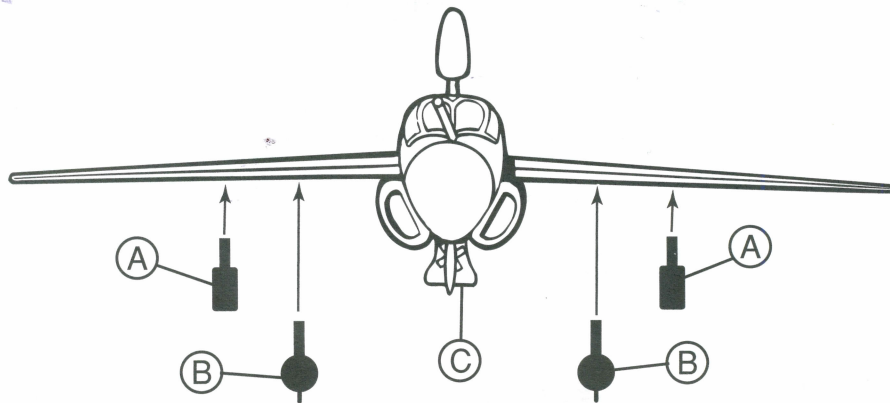

(A)

RIGHT SIDE

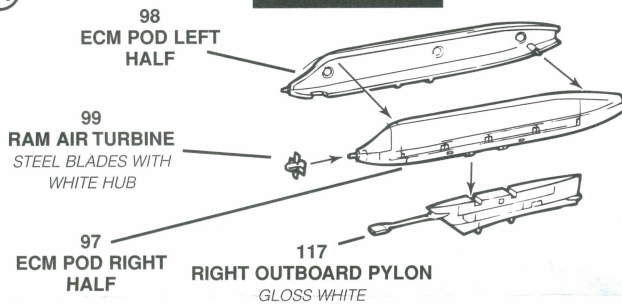

LEFT SIDE

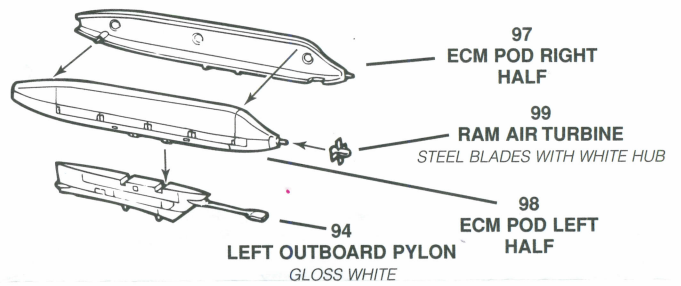

(B)

RIGHT SIDE

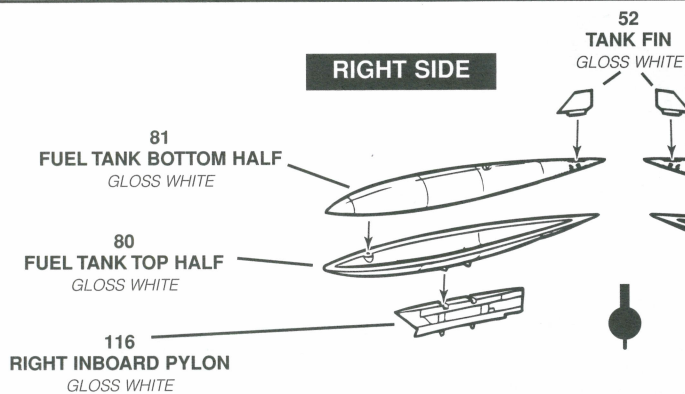

LEFT SIDE

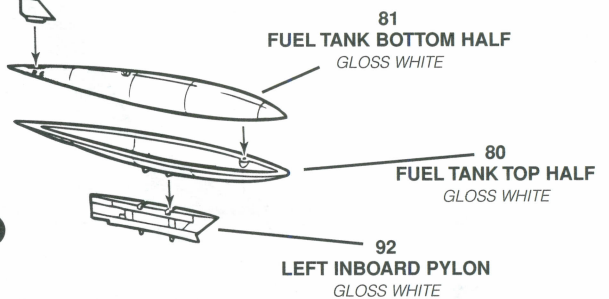

(C)

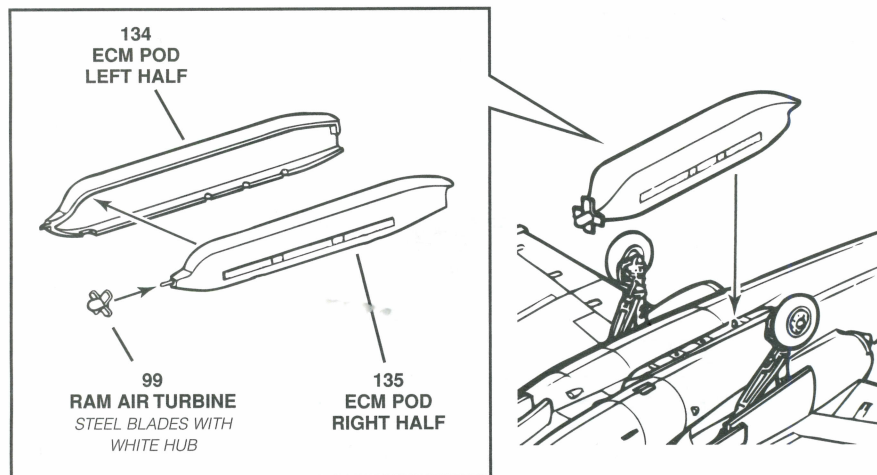

DECAL PLACEMENT

EA-6B PROWLER

- GLOSS WHITE
- FLAT DARK GULL GRAY FS 36231
- GLOSS LIGHT GULL GRAY FS 16440
- FLAT TAN FS 33613

(LETTERS IN PARENTHESIS INDICATE DECALS WHICH ARE PLACED IN THE SAME POSITION ON THE RIGHT SIDE ONLY)

