

BRONCO

Bronco Models

Sturmgeschütz III Ausf D (SdKfz 142) in North Africa

二战德国三号D型突击炮北非战场

1/35 SCALE

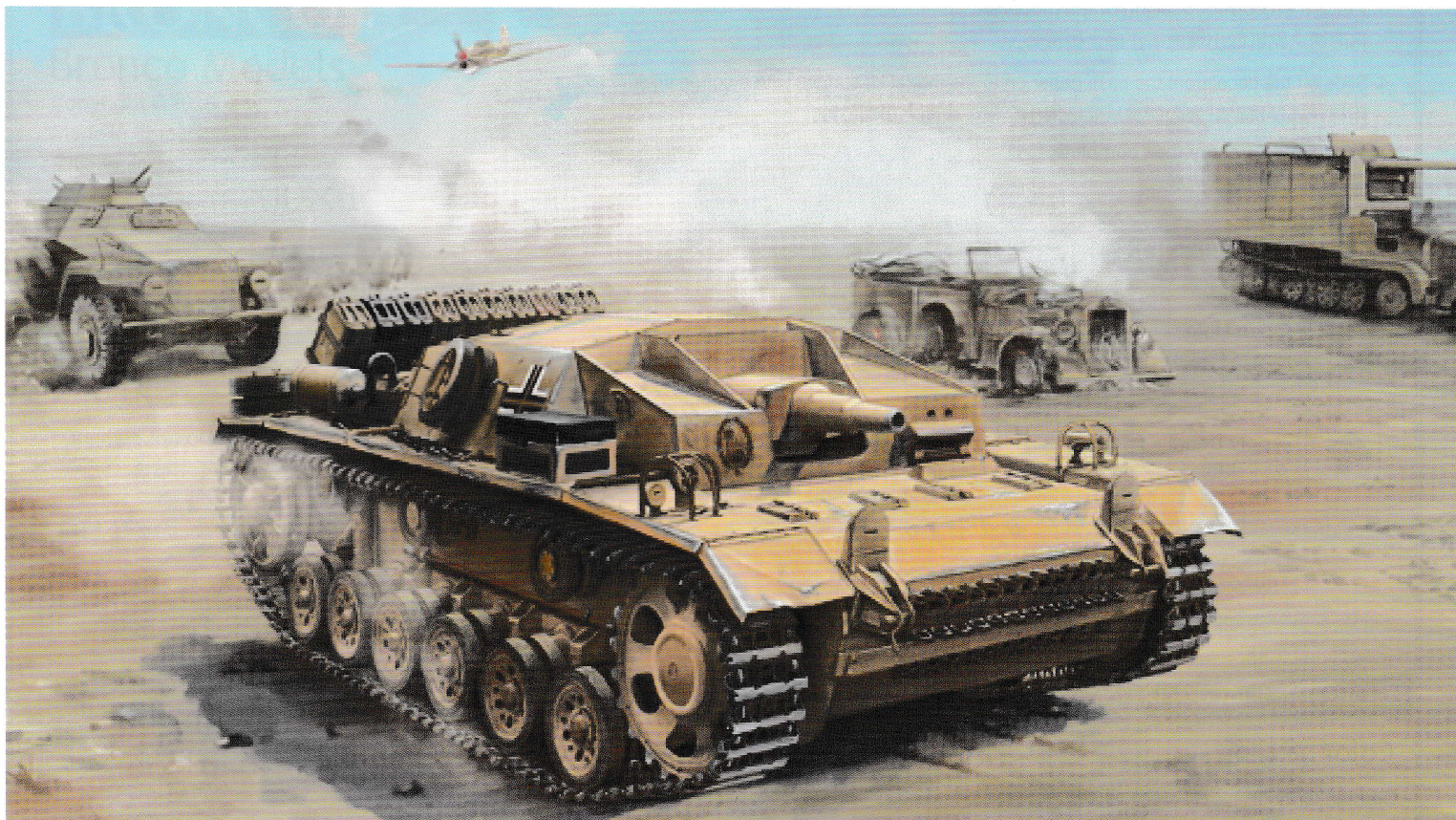

In early 1941, two new model of the StuG III introduced. There are StuG III Ausf C and Ausf D. There is  no external difference between the two types. Ausf C and Ausf D re-designed superstructure which eliminated the front aperture for the gunner's sight.

Only three StuG D served in north Africa with Sonder Verband 288. This was a tropicalised vehicle with additional air in takes cut into the rear deck access hatches that were covered by armour cowls.

Gepanzerter Selbstfahrlafette für Sturmgeschütz 7.5cm Kanone Ausf.D. in numbers:

Length: 5.40m

Hull Width: 2.93m

Height: 1.98m

Crew: 4

Weight: 20.8 tons

1941年的早期，德军研制出了一个新型的III号突击炮。改进了前面装甲的耐久性和简化了车身的制造。即为III号C/D型突  击炮。D型使用了III号坦克H型的底盘，在上部车体外形也有所变化，在车体右侧增加了装填手舱口，德国人于是把这些突击炮统称为III号C/D型突击炮。III号C/D型突击炮从1941年5月至12月共生产了200辆。在1941年夏天，III号C/D型突击炮参加了首次战斗，直至在冬天还有一些突击炮仍在使用的。甚至在1945年德军装甲部队严重缺少的情况下，III号C/D型突击炮换装长型火炮后被再一次地投入战斗。一些D型随隆美尔军团的特种装备营参加了北非的战斗。并参与了攻克托布鲁克的坦克战。

ILLUSTRATION 图示说明：

CORRECT METHOD FOR APPLYING DECALS : 正确使用水贴纸的方法：

1. Clean model parts surface with wet cloth.
将需要贴水贴之部位表面擦干净。
2. Cut out the decal parts and dip them in cold water for 15 ~20 seconds.
将所需之贴纸剪下泡在清水里约15至20秒。
3. Place it on correct position of the model kit.
将湿透之贴纸取出置放于正确之位置旁。
4. Slide off the decal from the base paper on to the model kit surface with a cotton stick.
用棉花棒轻推贴纸表面使其从底纸滑出至模型表面之正确位置。
5. When decal get dry then complete.
待其自然干透后即完成。

ICON INSTRUCTION: 图标说明：



Open Hole
钻孔



Remove
切除



Make 2 pics
同样的制作二组



Bend
曲折



Optional
可以选择采用



Apply Decal
贴水贴纸



Instant Glue For Metal
瞬间接着剂,金属用



Fill Hole
把孔填平



Do not cement
不用粘合

COLOR SUGGESTION: 涂装指引：

Color 涂料表		Hobby Color	MR. Hobby	Humbrol	Tamiya
German Gray	德国灰	H-32	C-40	92	XF-63
Tyre Black	轮胎黑	H-77	C-137	85	XF-1
Steel	黑铁色	H-18	C-28	53	/
Flat Black	消光黑	H-12	C-33	33	XF-1
Wood Brown	木棕色	H-37	C-43	/	/
Brunt Iron	烧铁色	H-76	C-61	/	/
Dark Yellow	暗黄色	H-79	C-39	83/93	XF-60

READ BEFORE ASSEMBLING: 组装必读：

- Carefully Study instruction before assembling. 组装前请阅读清楚制作指引。
- Keep plastic model glue and tools away from children. 胶水,油漆及工具勿让小孩接触。
- Do not use cement or paint near open flame or sparks. 胶水及油漆勿接触火种。
- Do not work in closed room. 勿在密封地方制作模型。

Printed in China

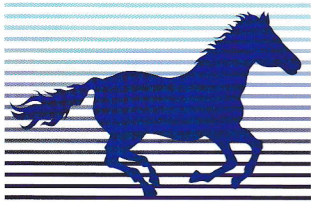

BRONCO

Bronco Models

Copyright ©2016

Made in China

中国制造

No use parts
不要部件

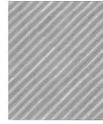

Metal barrel

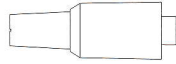

Copper wire × 2
铜丝



Ⓐ × 1

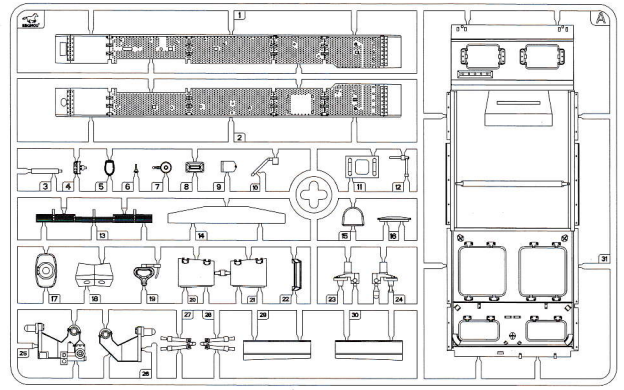

Ⓑ × 1

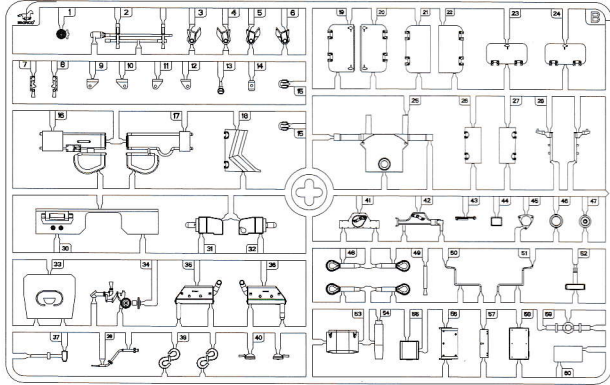

Ⓒ × 1

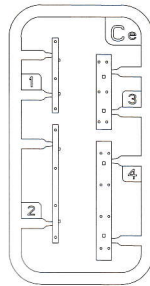

Ⓕ × 1

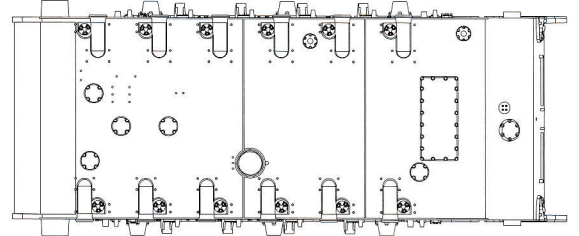

Ⓜ × 1

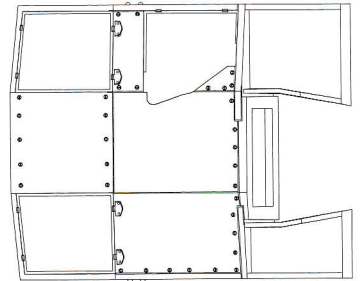

Ⓒ_b × 2

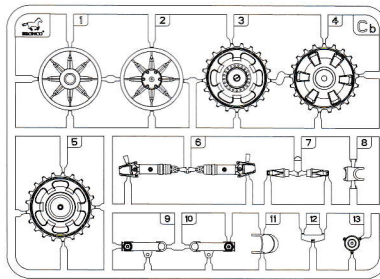

Ⓒ_a × 2

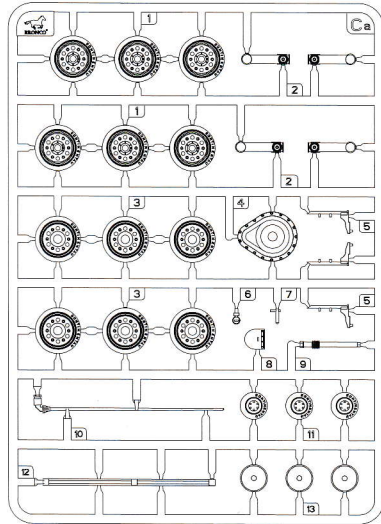

Ⓕ × 1

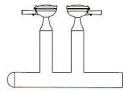

Ⓕ × 1

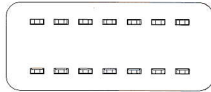

Ⓒ_a × 1

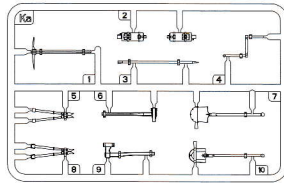

Ⓜ_a × 1

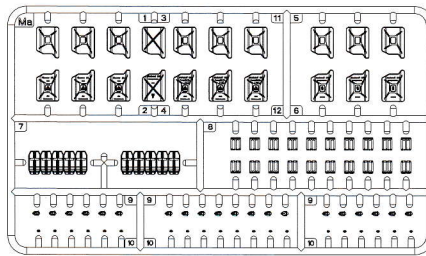

Ⓒ_a × 1

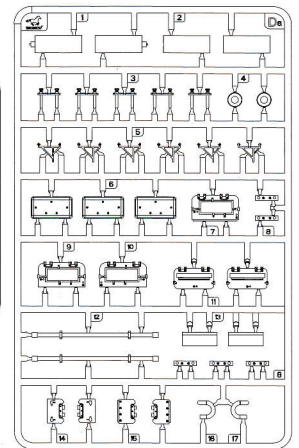

Ⓖ × 4

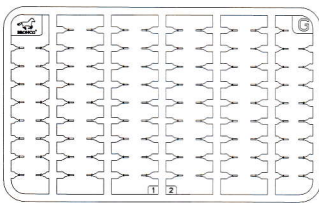

Ⓒ_b × 1

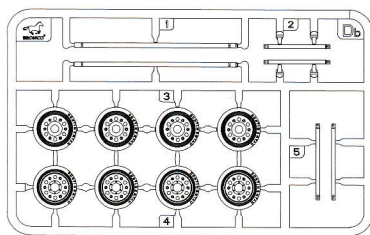

Ⓒ_c × 1

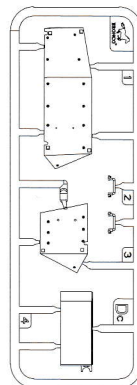

Ⓟ × 1

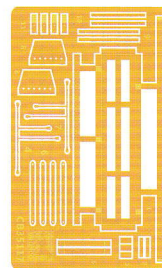

Ⓒ_c × 1

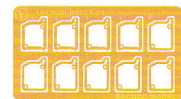

Ⓒ_a × 1

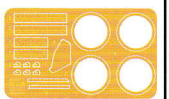

Ⓝ × 1

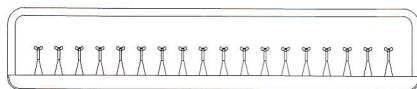

Ⓒ_b × 1

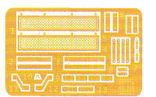

Ⓢ × 18

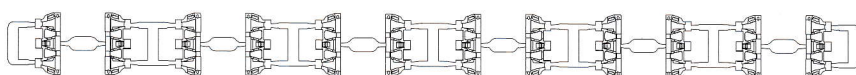

DECAL × 1



CB35117

ILLUSTRATION 图示说明：

Caution: This kit contents a lot of small accurate parts, please carefully to read before to assembly.

此套件包含不少精细零件，请在制作前先翻阅说明书了解清楚。

1

Wheels assembly 轮子组装

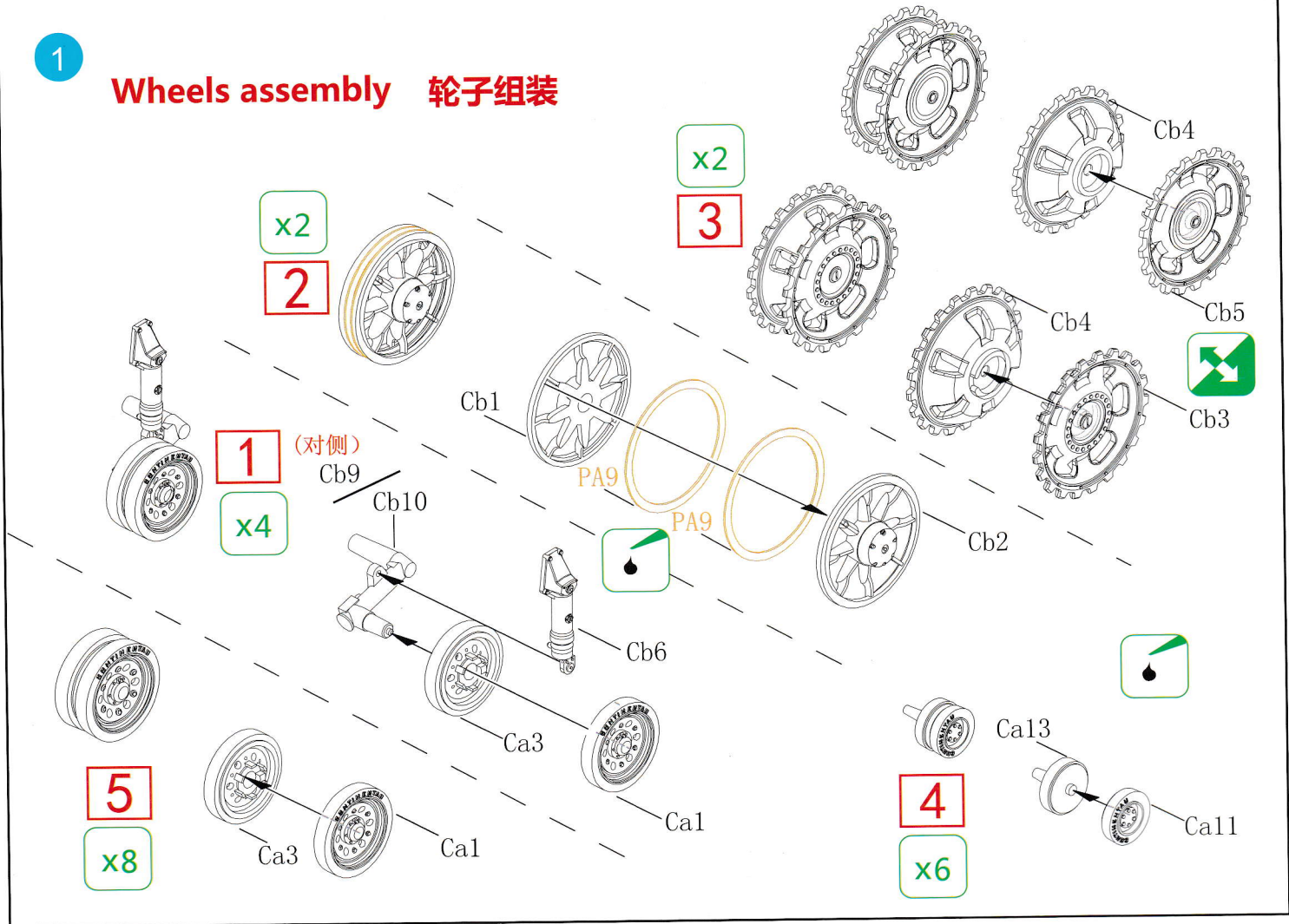

2

Making Hull & Suspension Arms 底盘组装

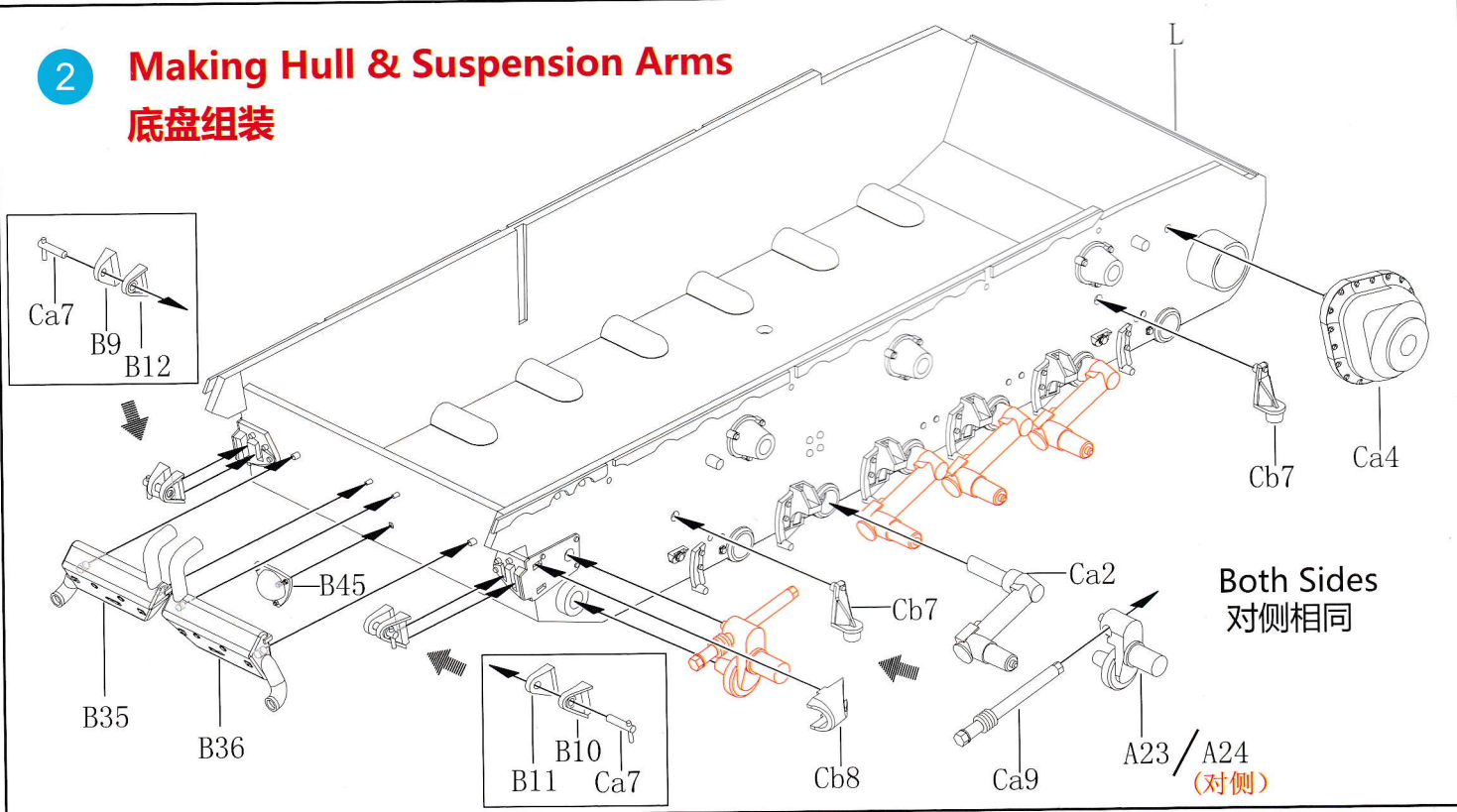

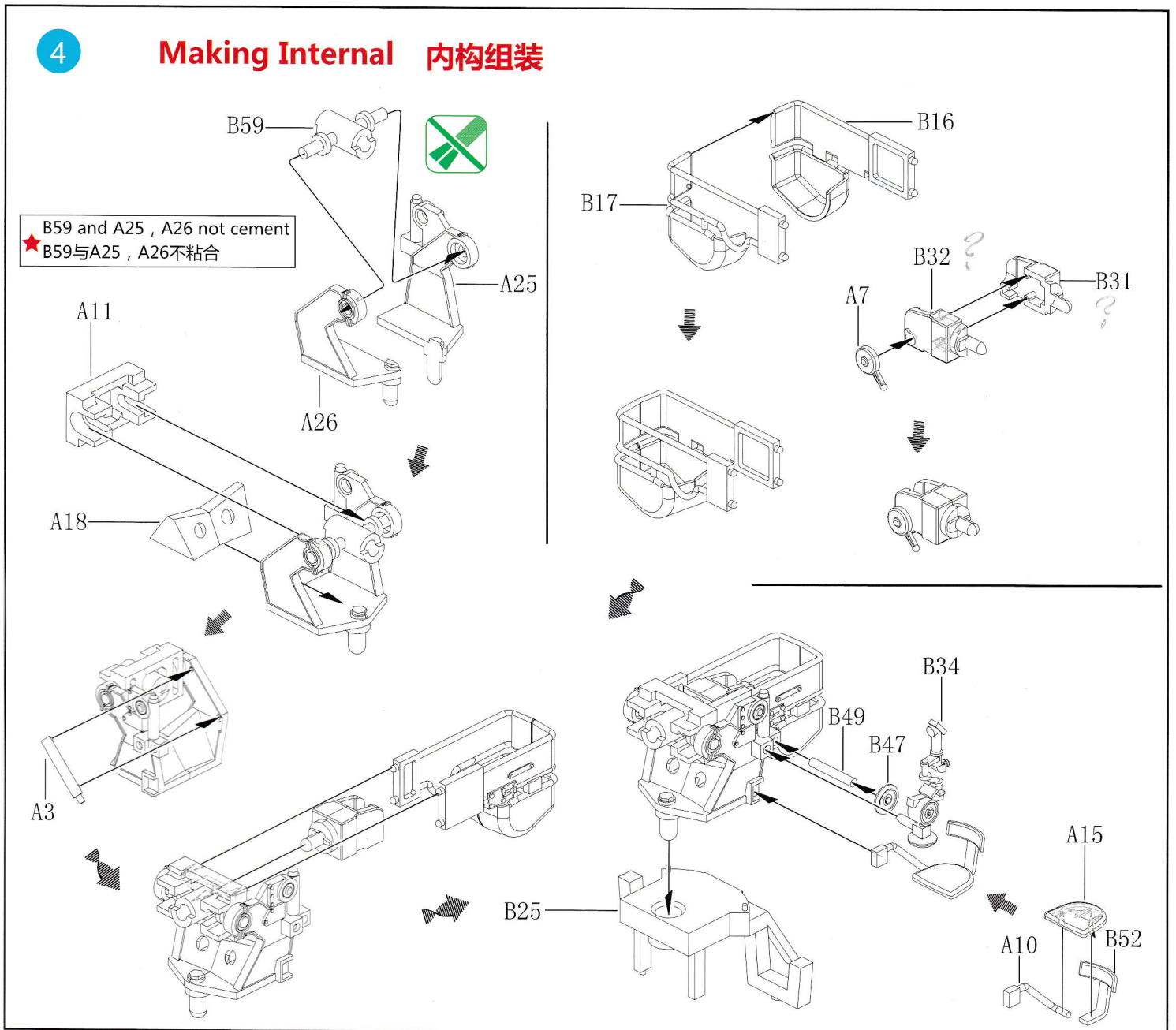
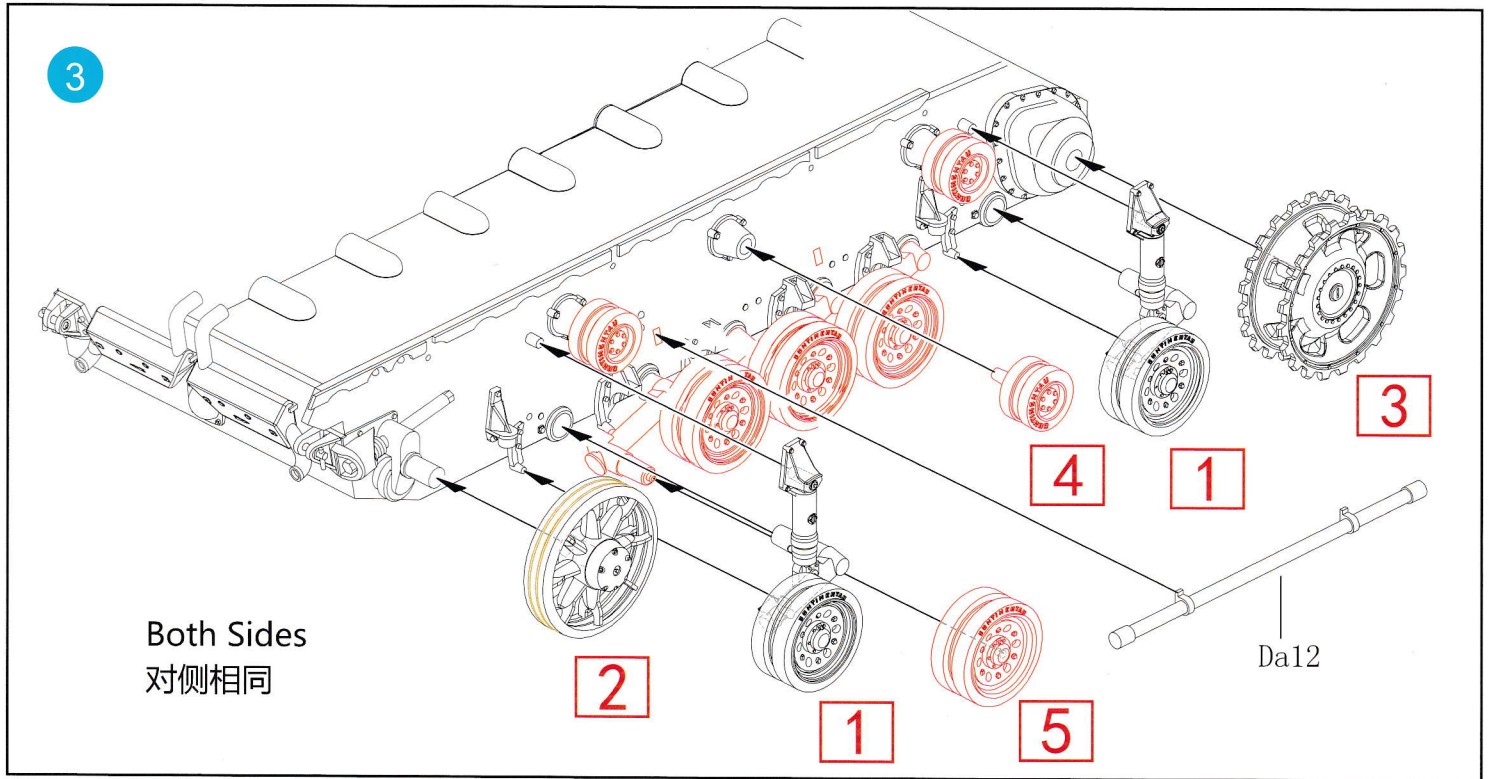

5

Glue The Parts and Select The
Appropriate Location
选择适当的位置粘合

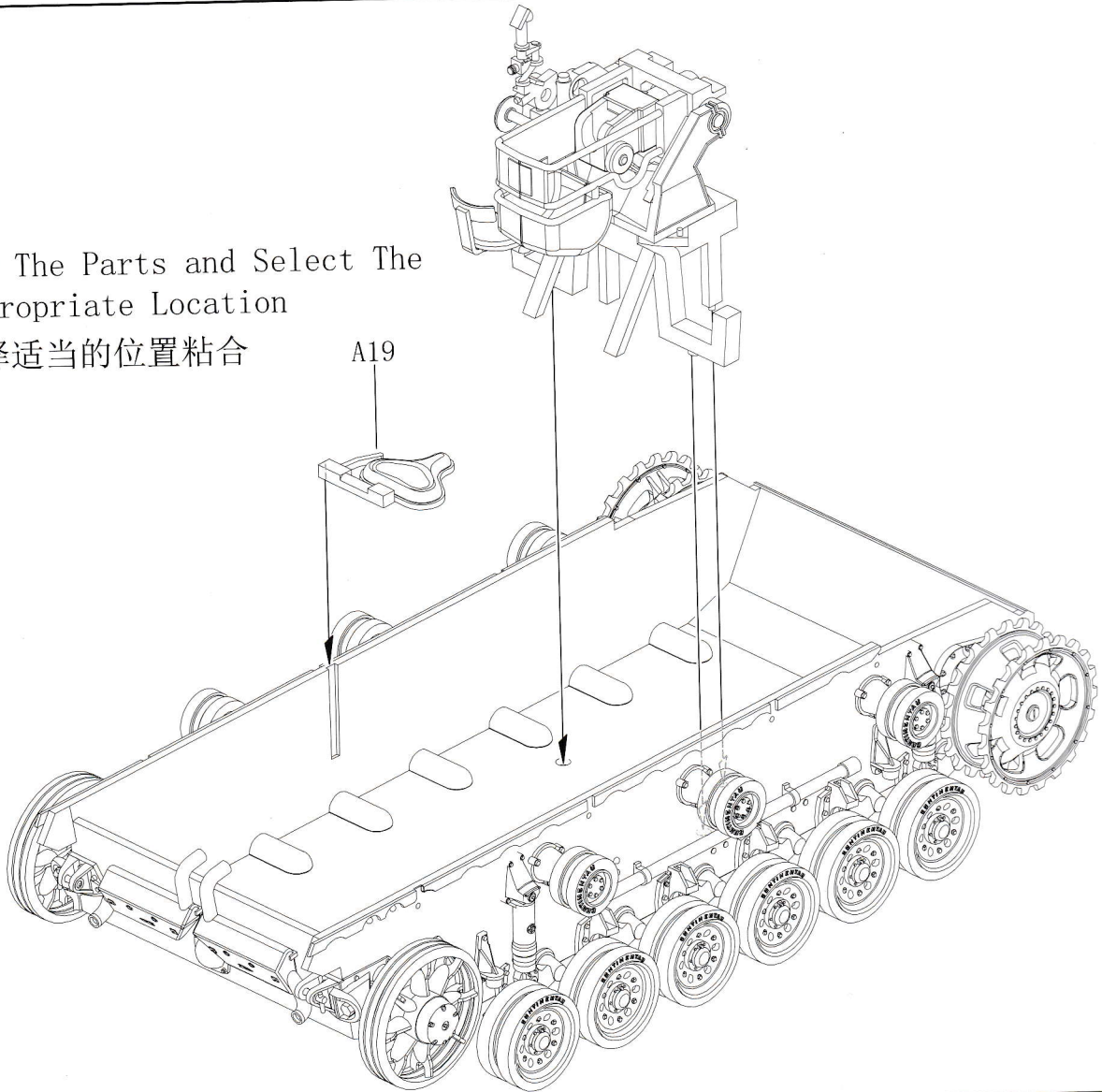

6

**Making Upper Hull
Installation**
车身组装

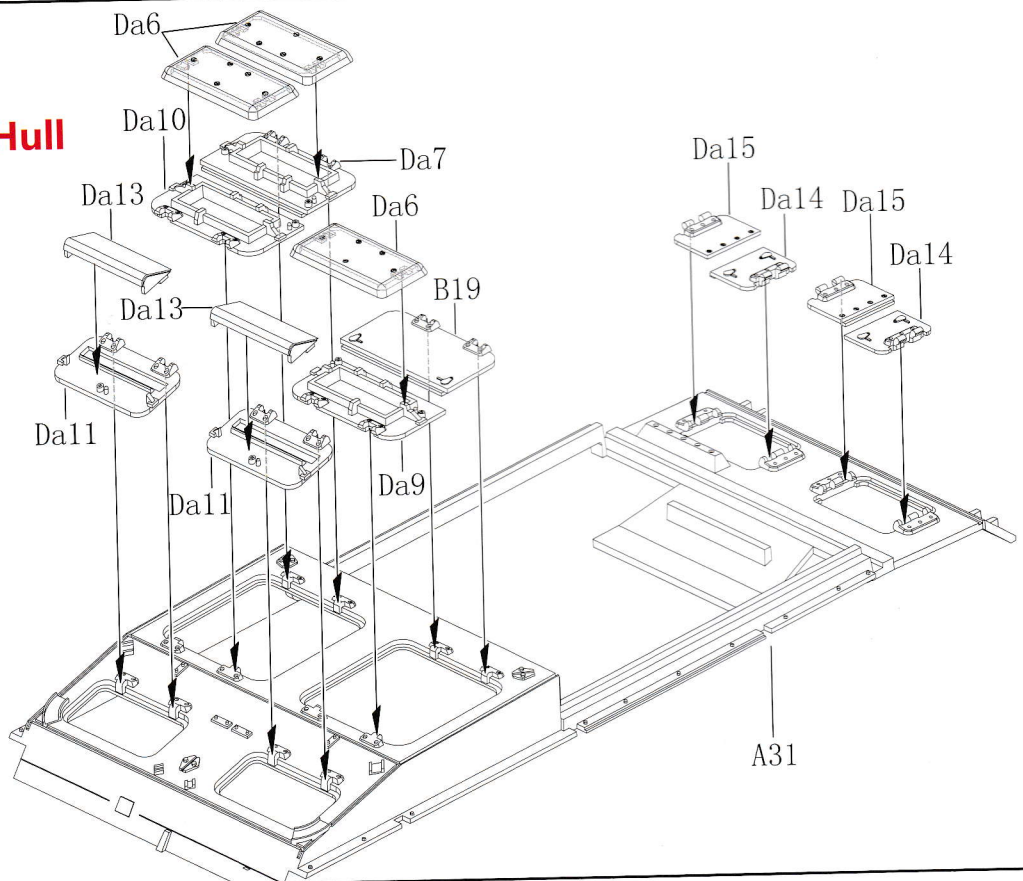

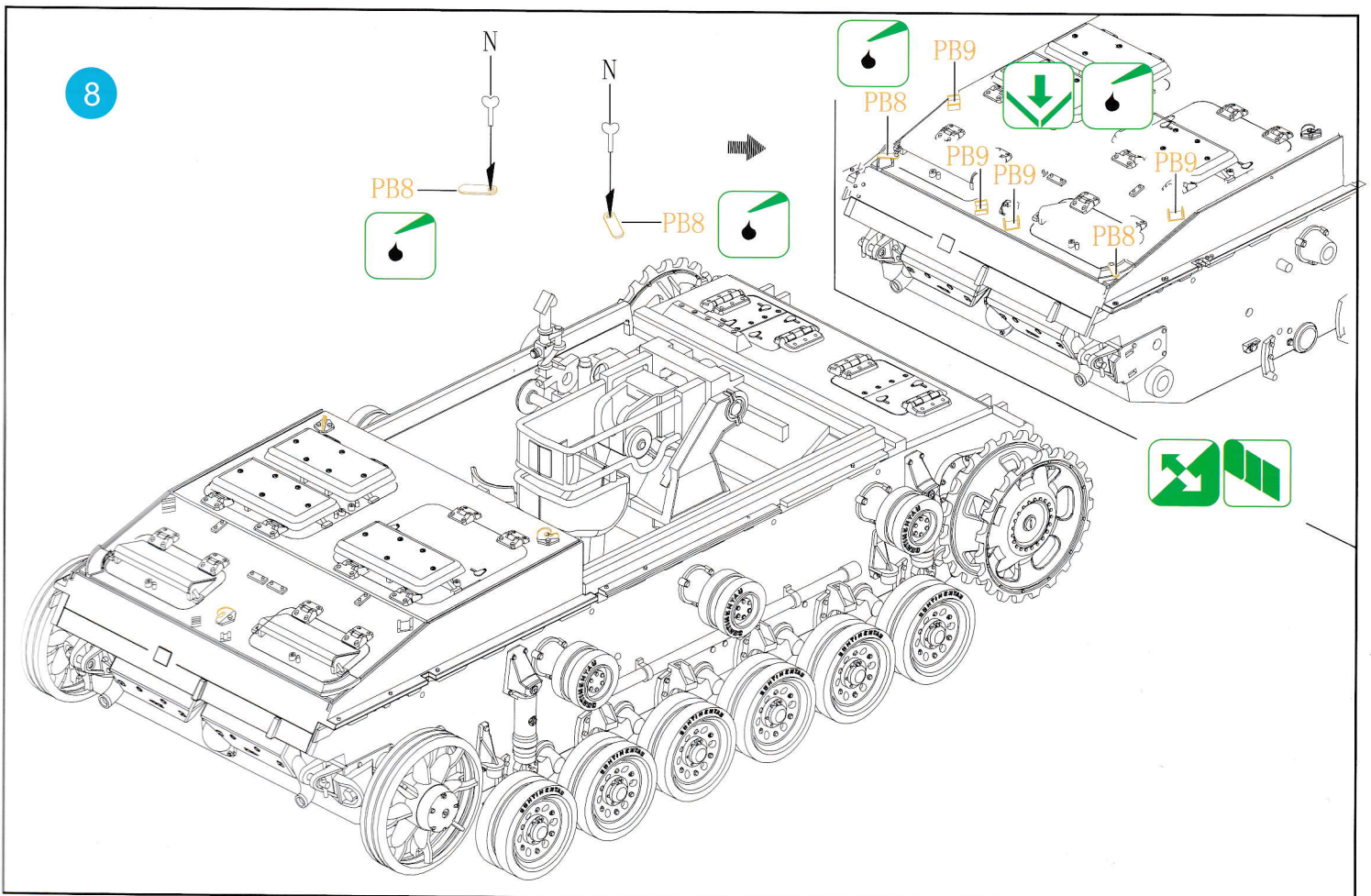
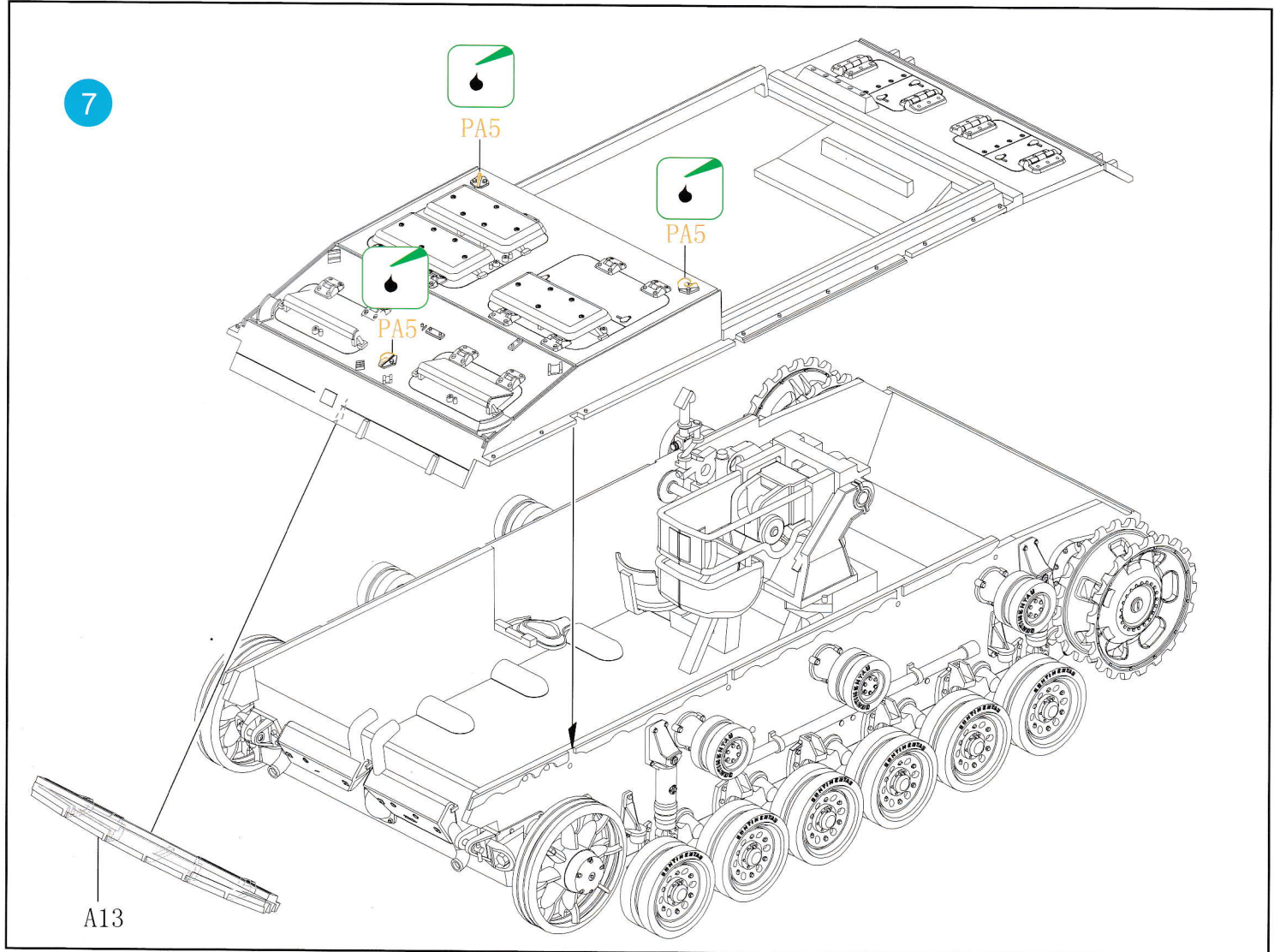

**9 Making Fighting Compartment
战斗室组装**

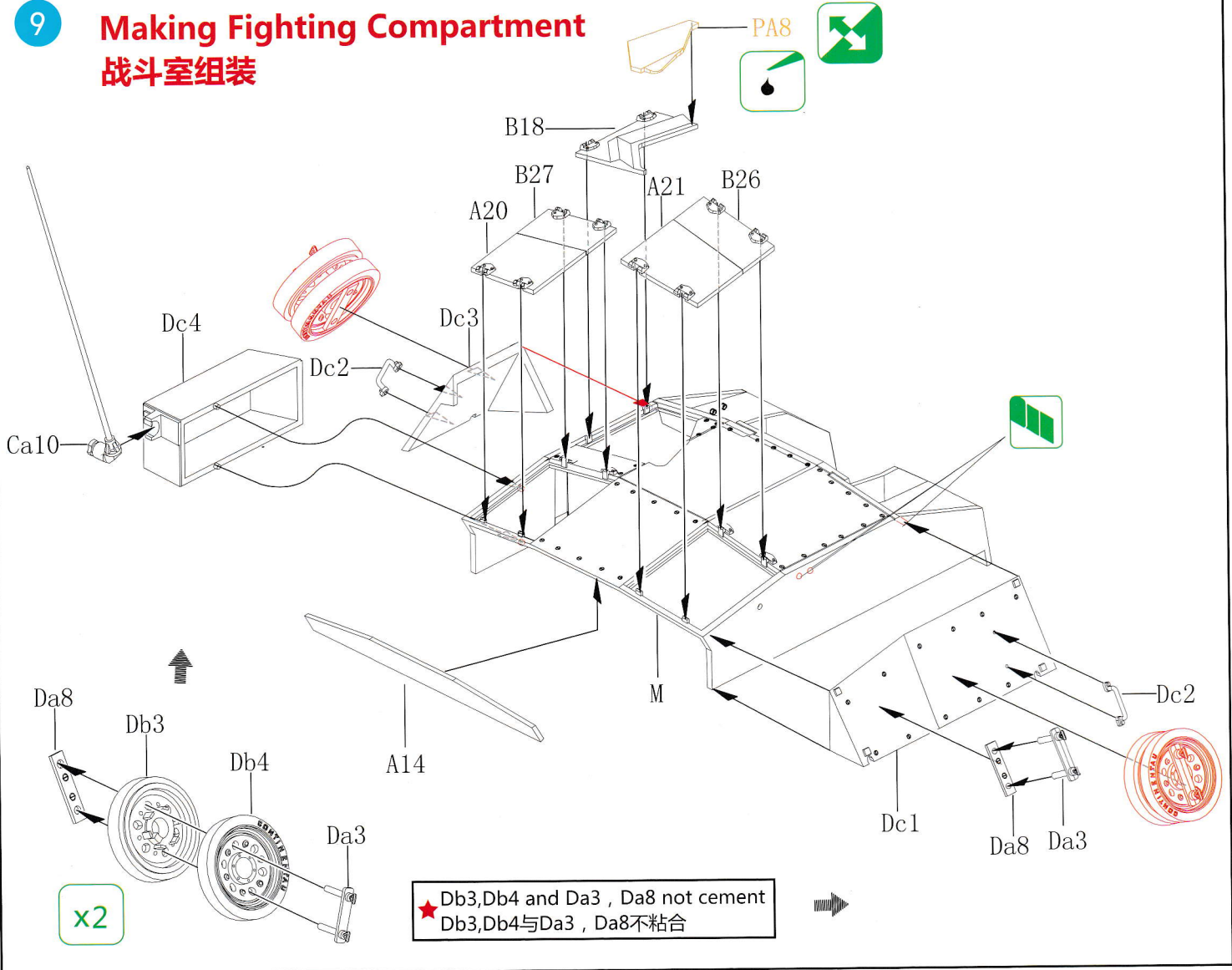

10

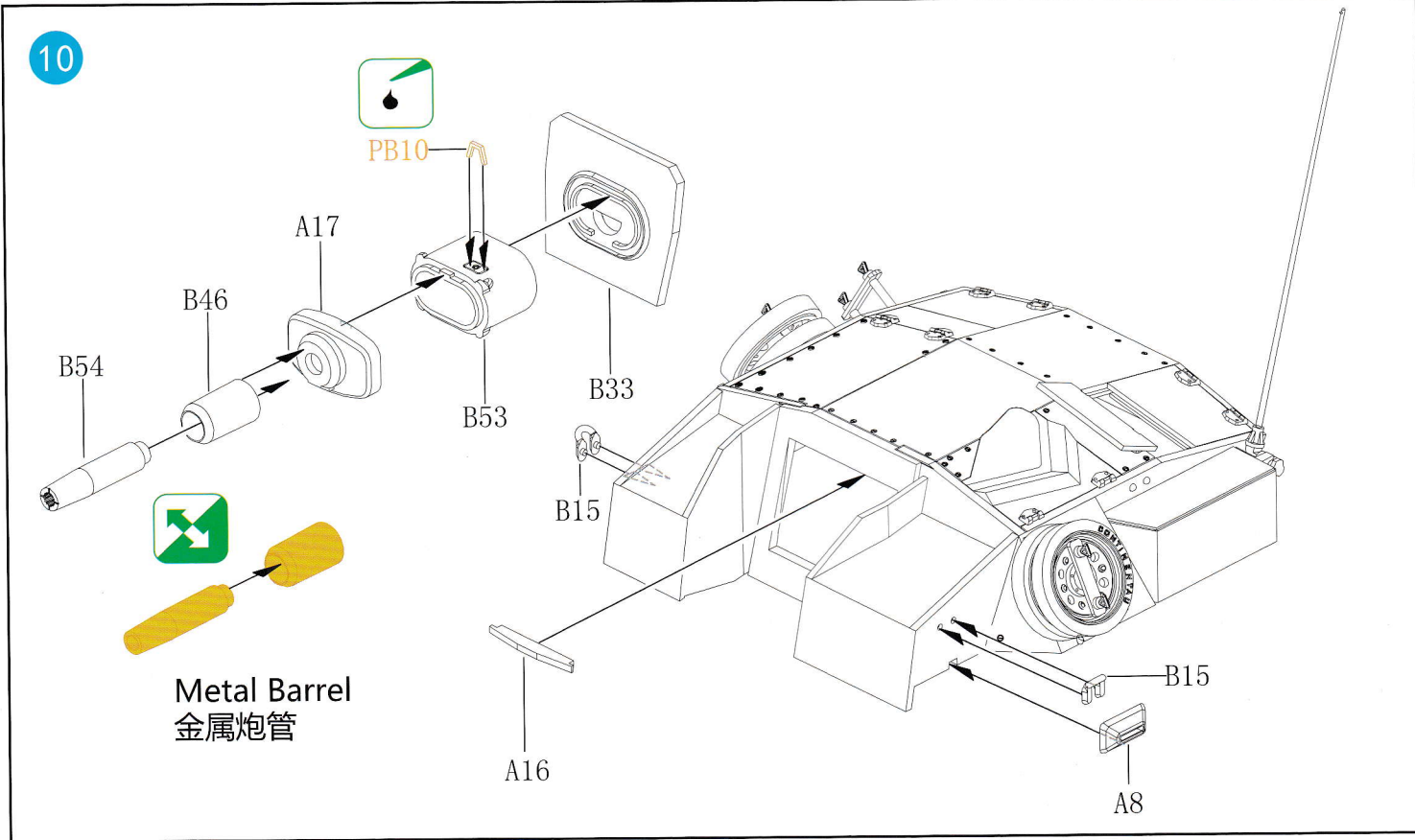
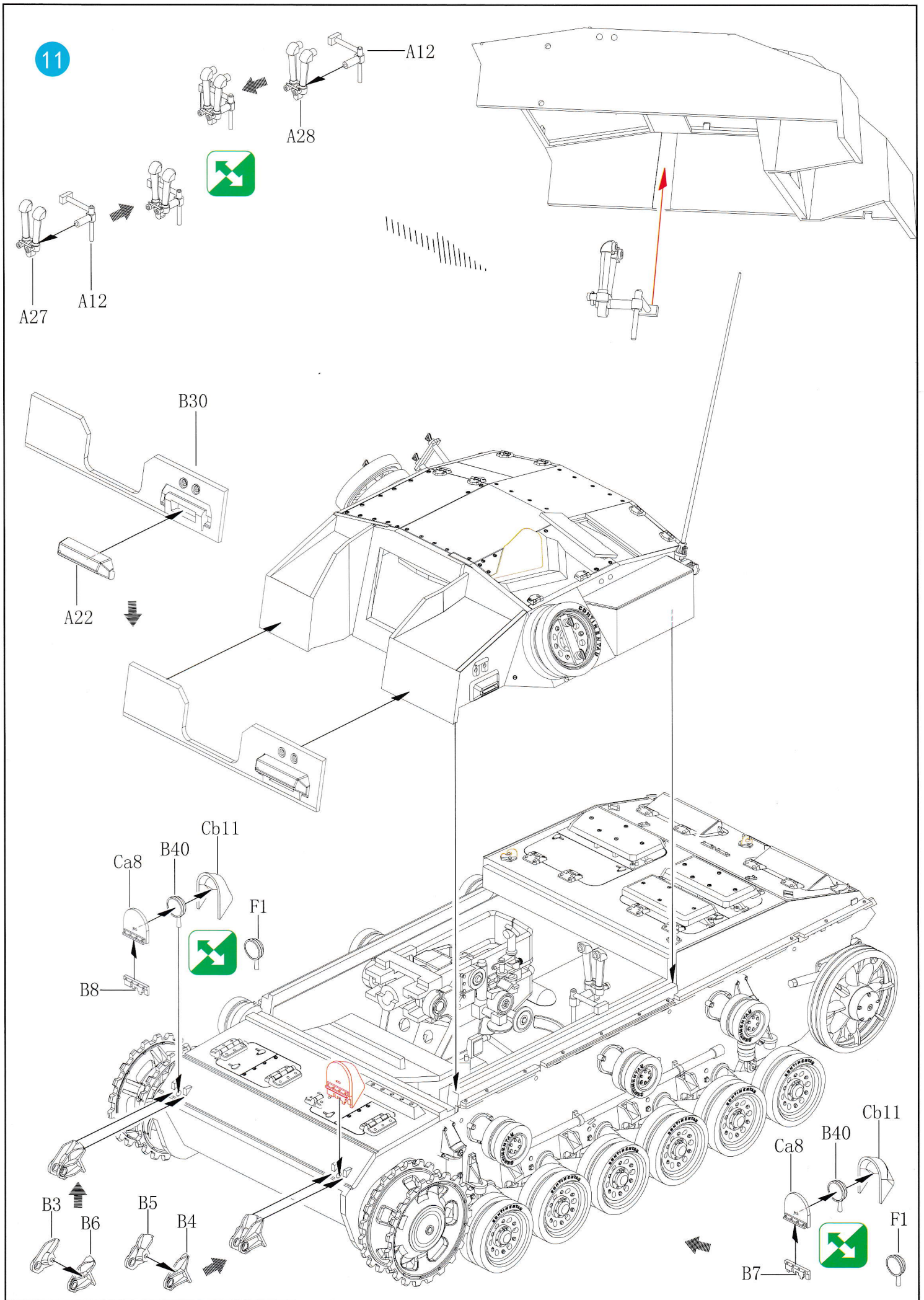

ILLUSTRATION 图示说明：



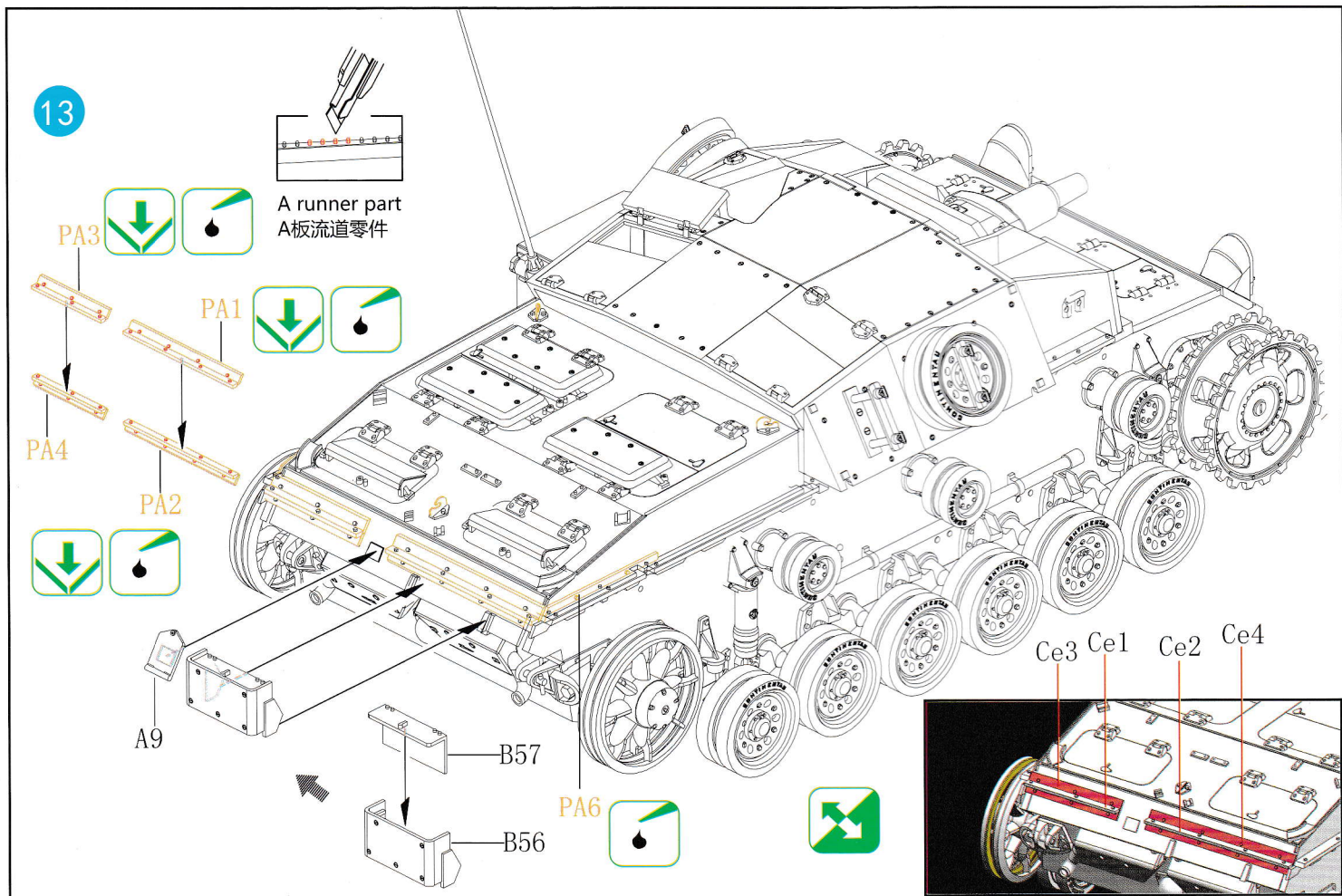
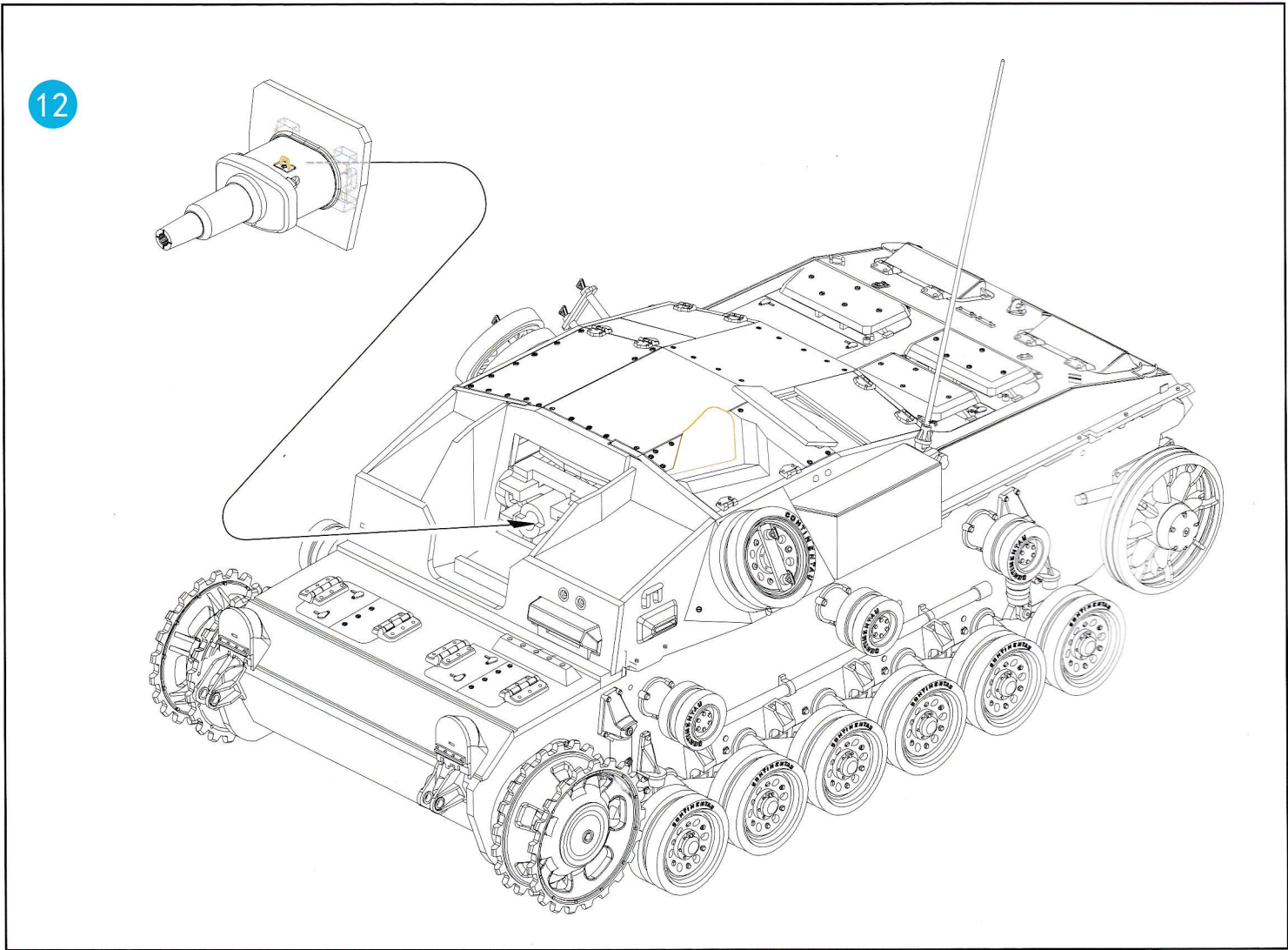
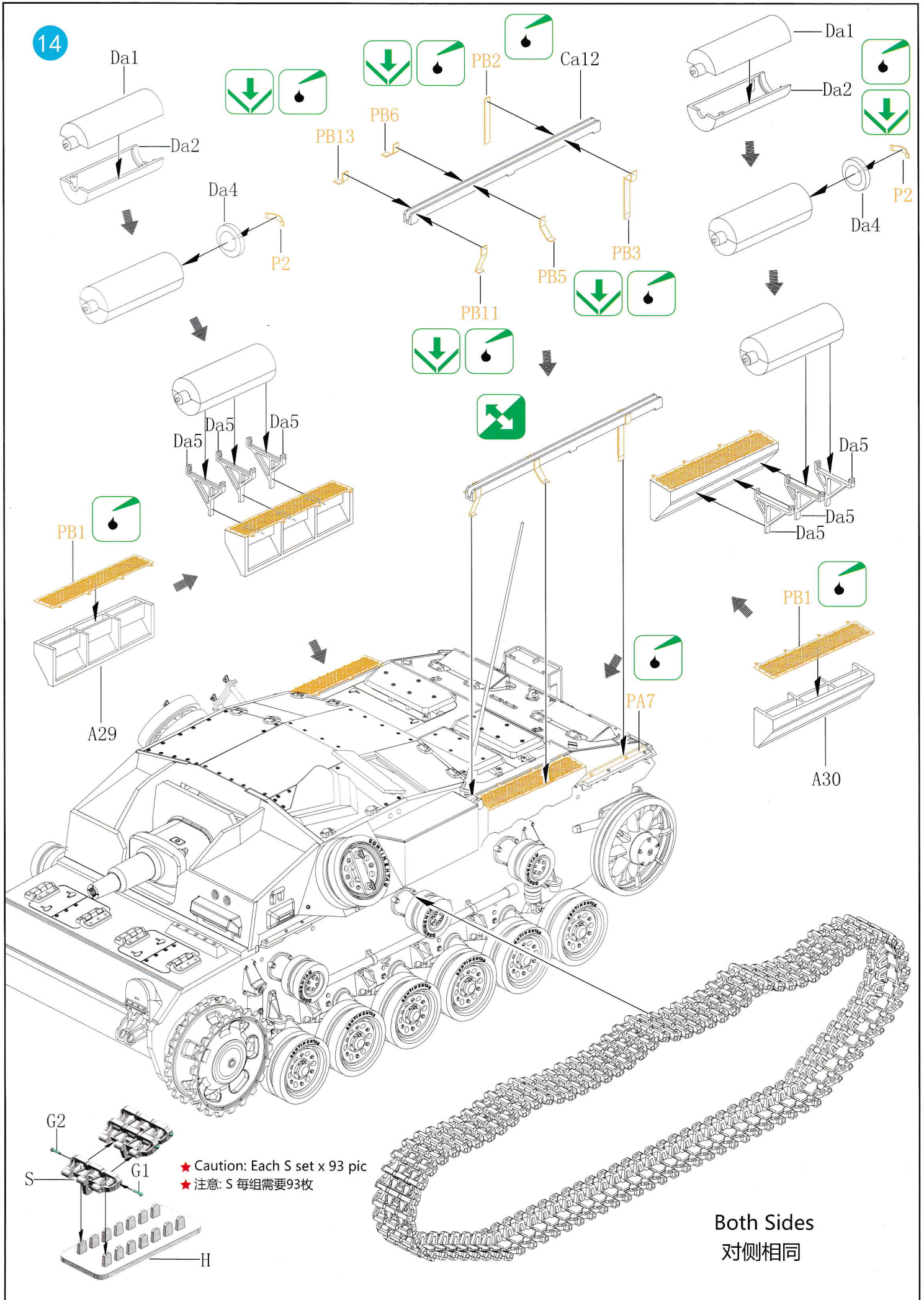

ILLUSTRATION 图示说明：



14

★ Caution: Each S set x 93 pic
 ★ 注意: S 每组需要93枚

Both Sides
 对侧相同

15 Making Angles and Tools 翼子板及车载工具组装

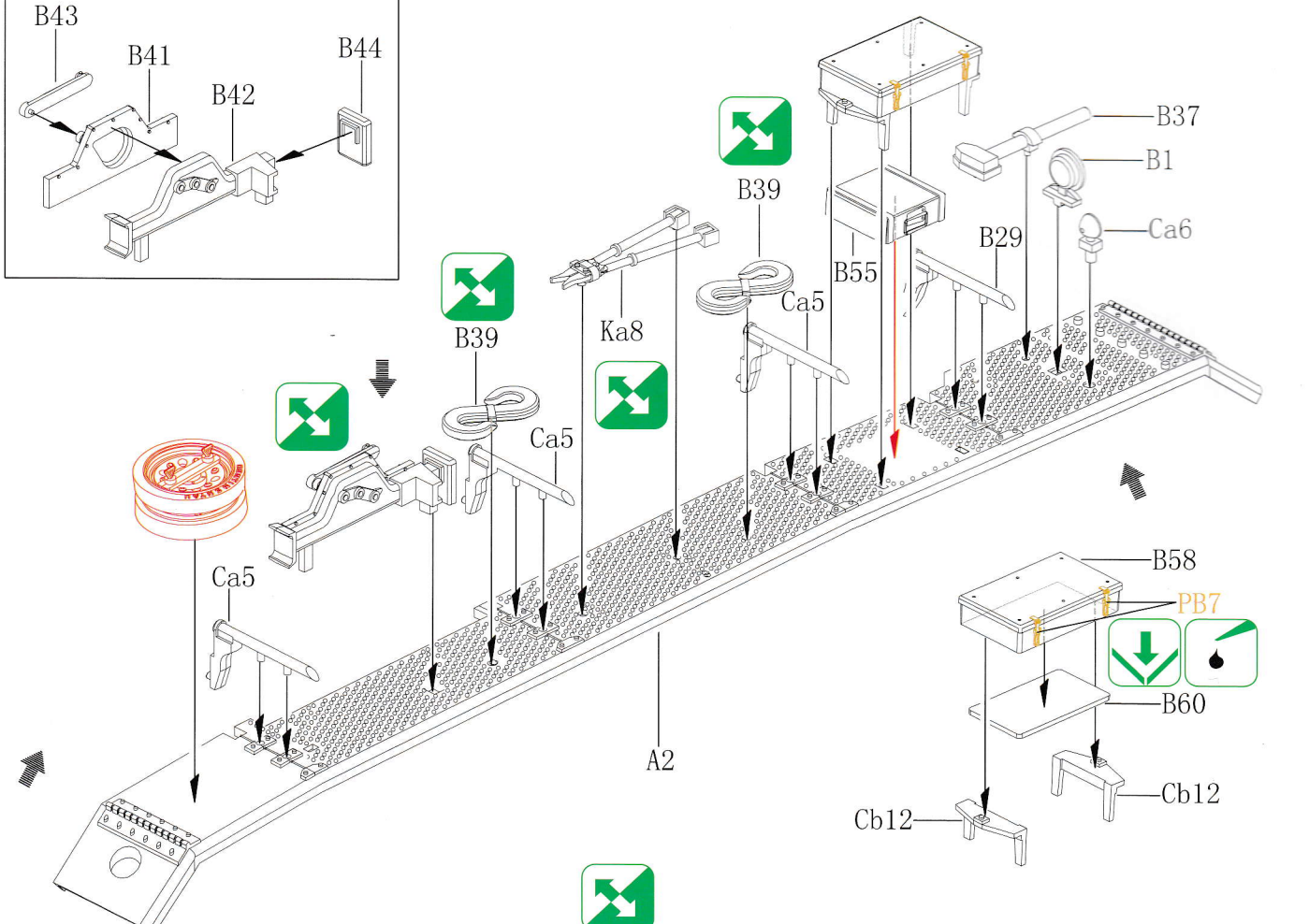
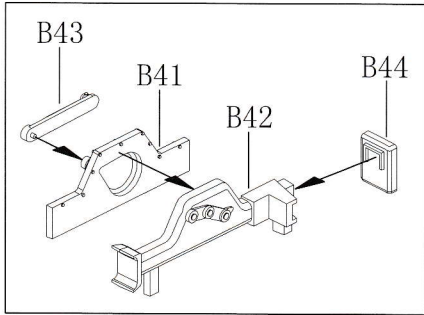

★ Db3, Db4 and Da3, Da8 not cement
Db3, Db4与Da3, Da8不粘合

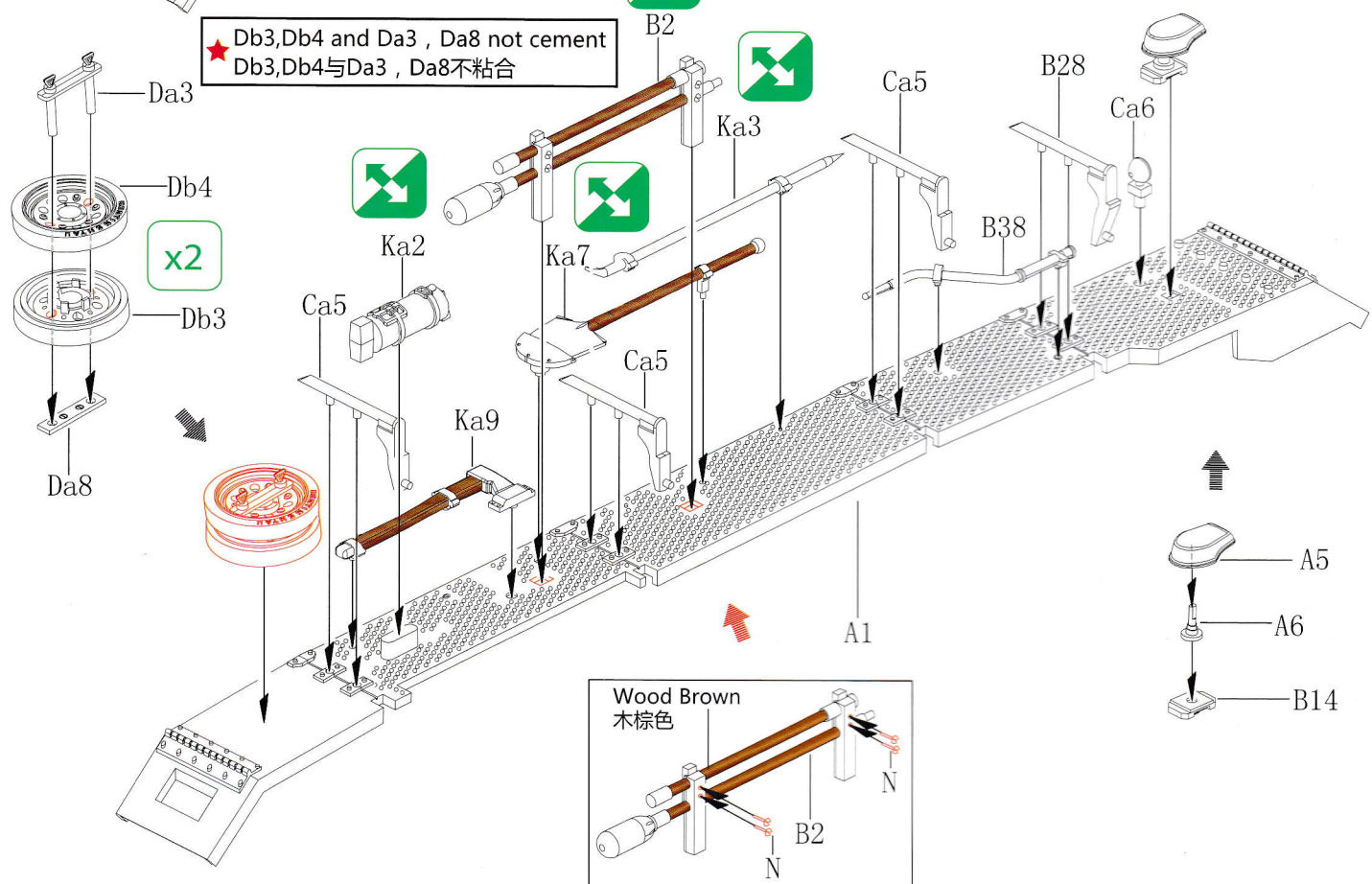

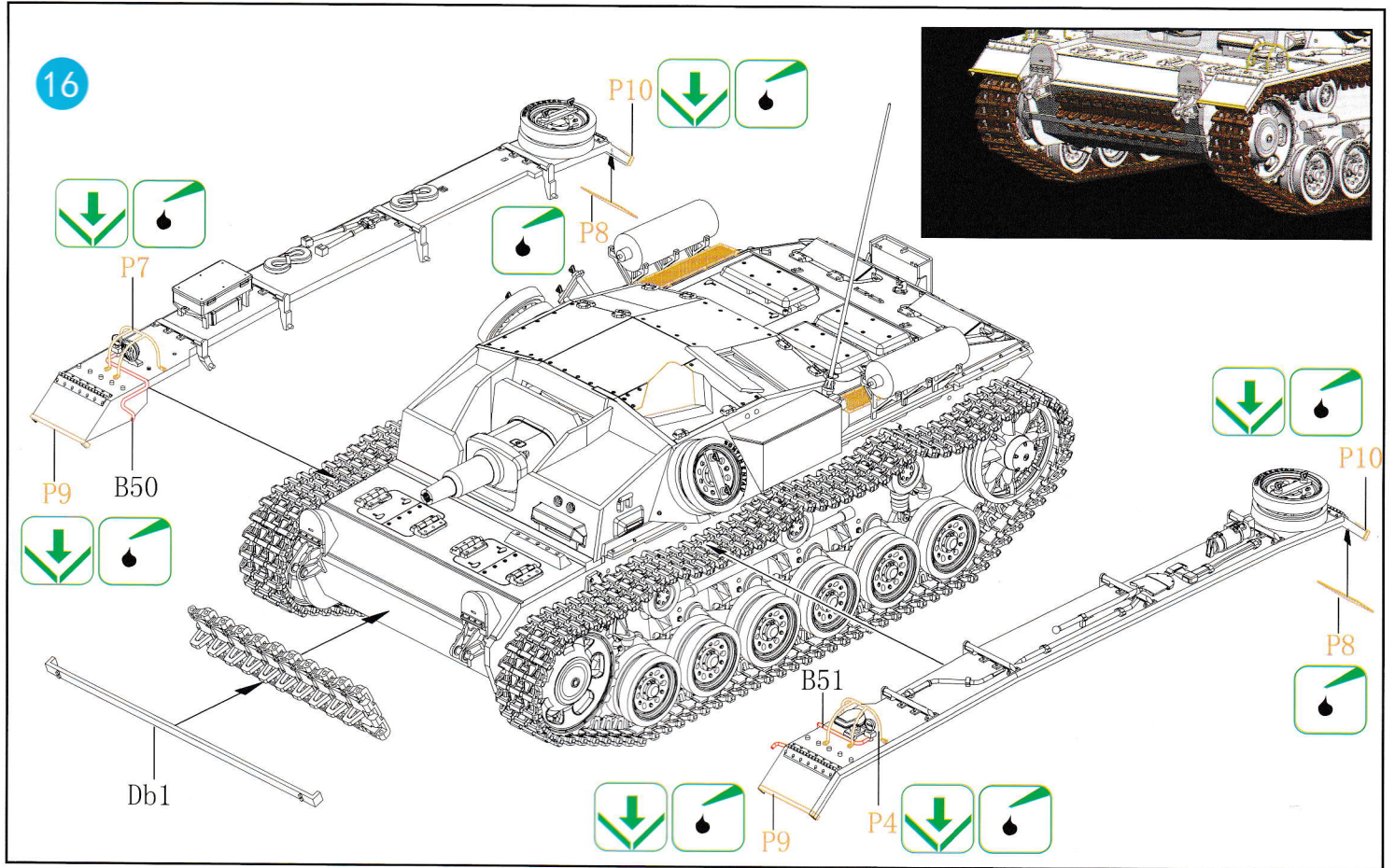

17 Oil and Water Jerrycans Assembly

油箱，水箱组装

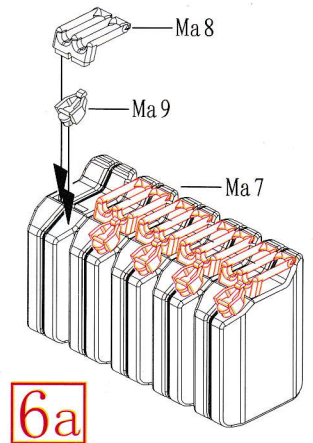
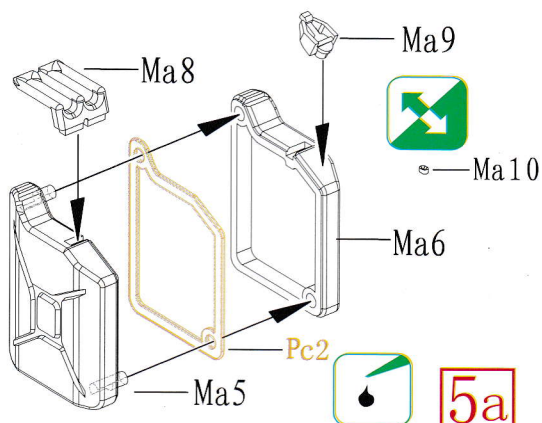
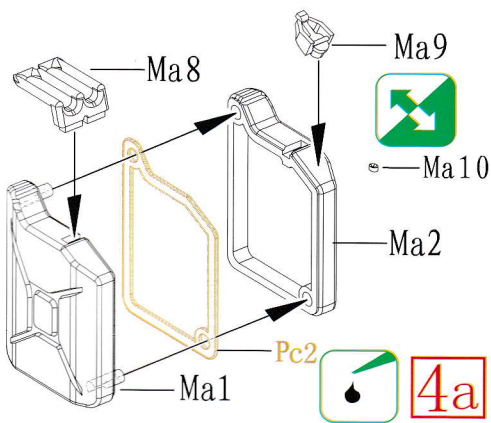
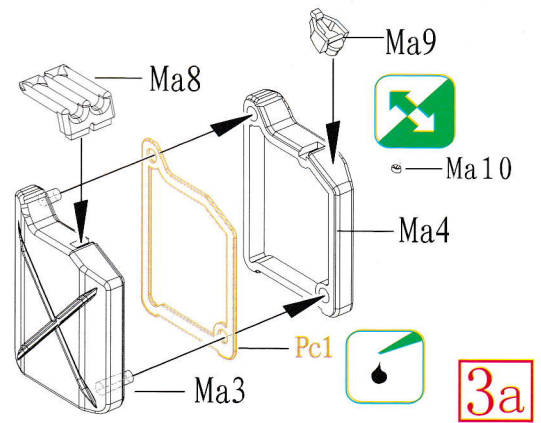
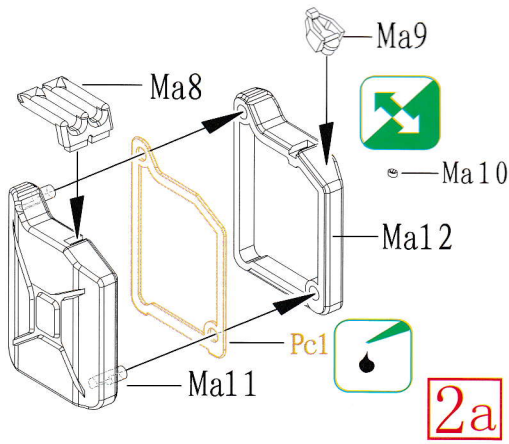

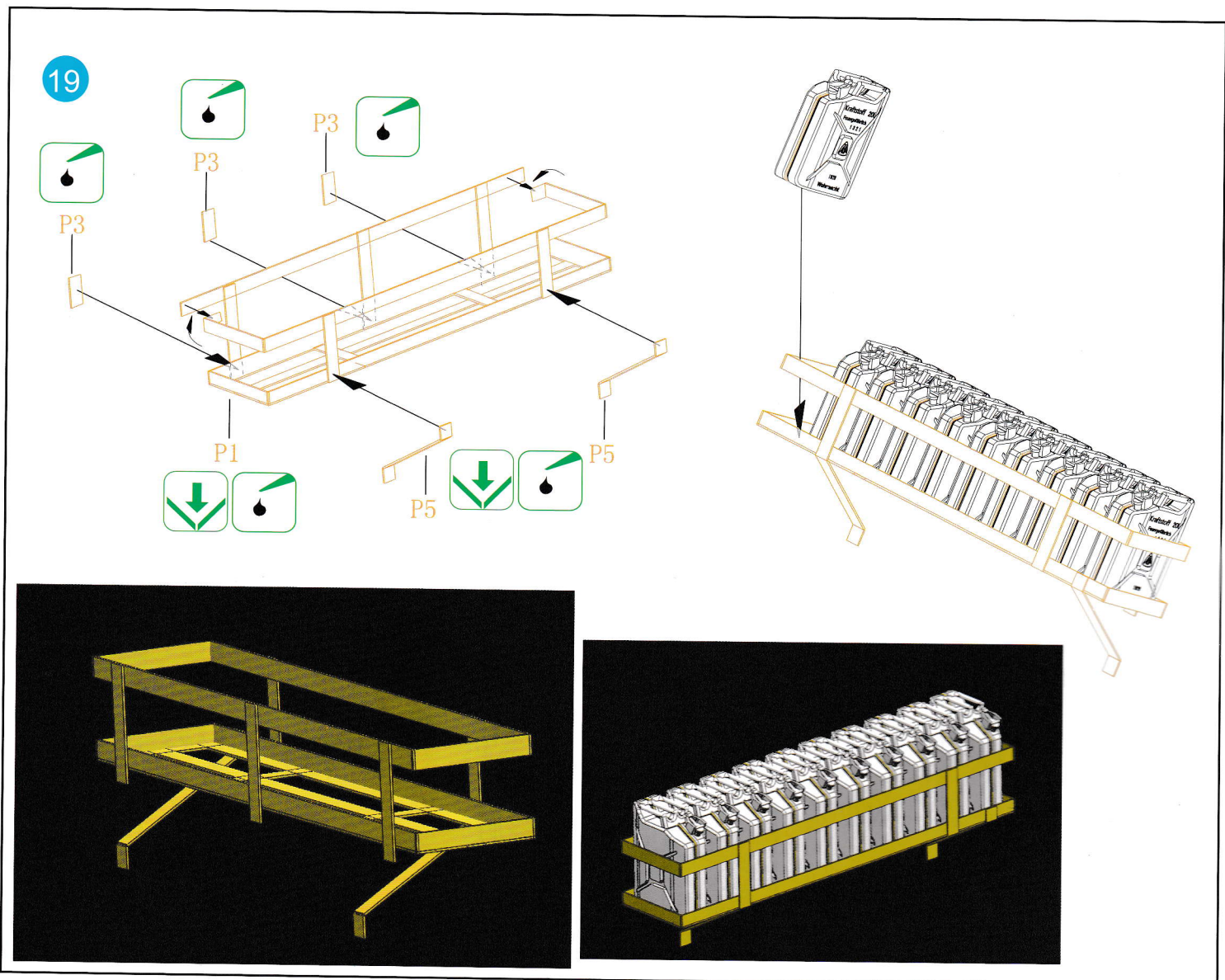
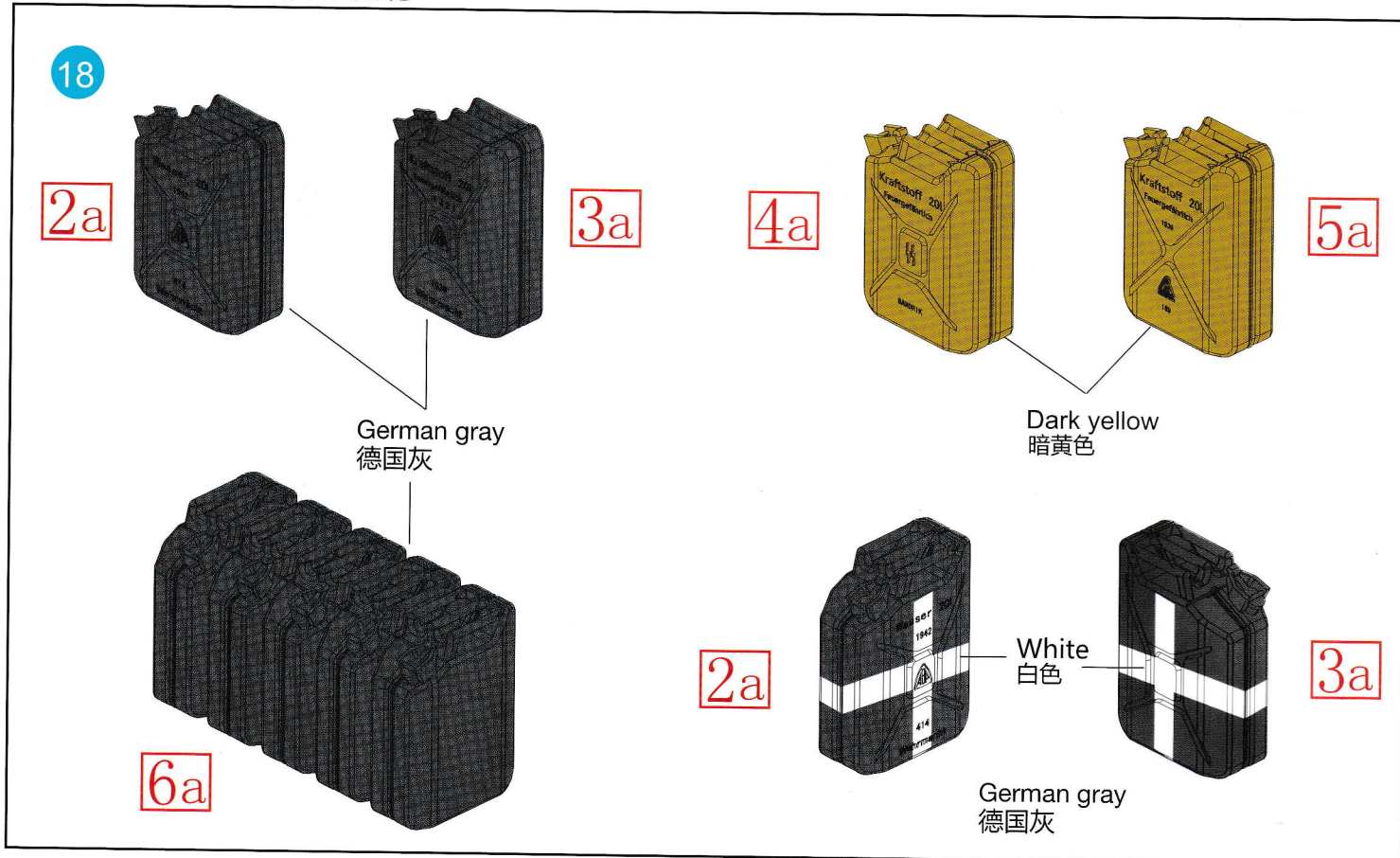

20 Option 1:
选装1

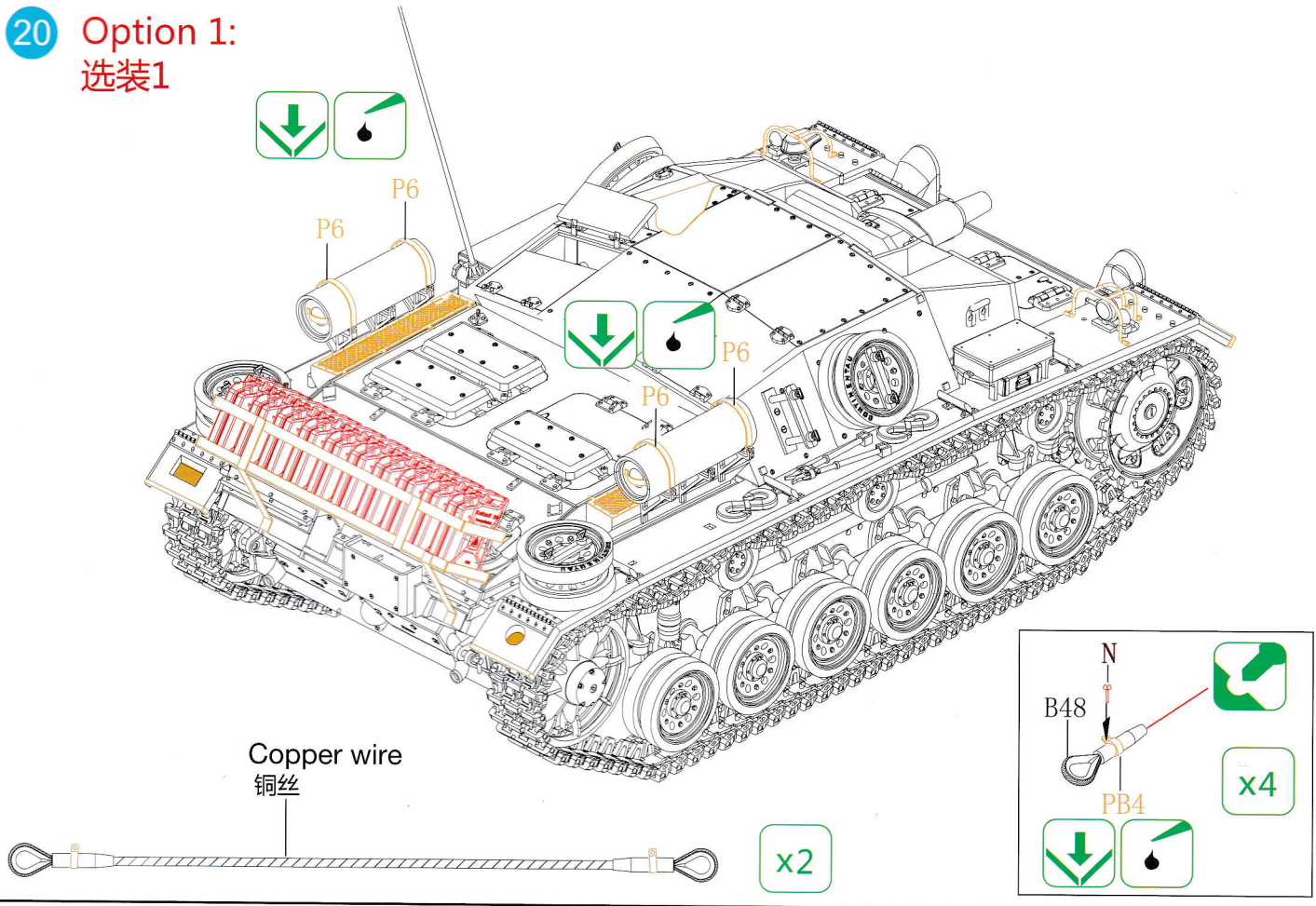

21 Option 2:
选装2

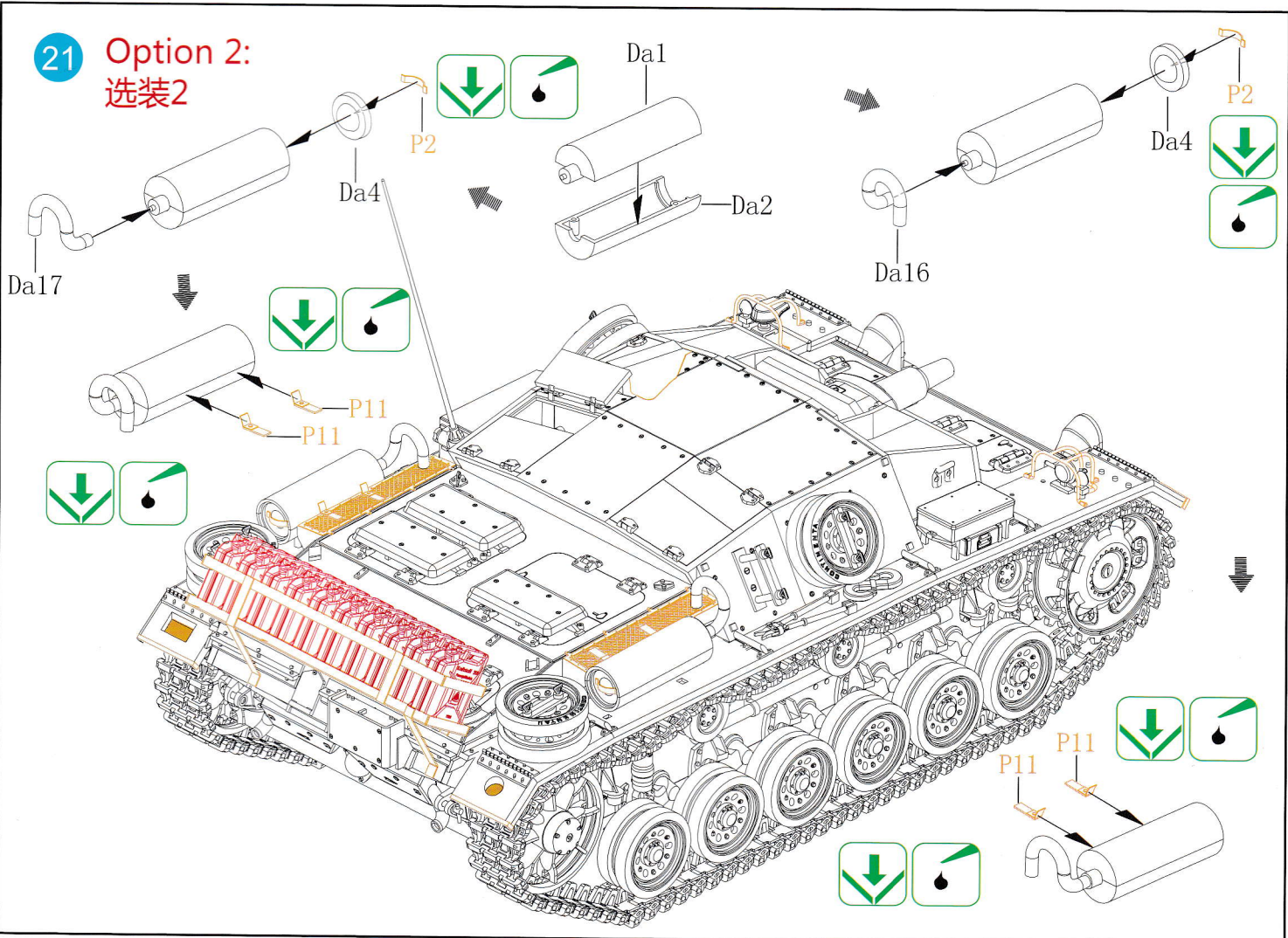

Option1: Sonder Verband 288. North Africa.1942

二战德国非洲军团第288特种装备营北非战场1942年.

