



BRITISH ARMY

SCOUT CAR DAIMLER Mk II

1/35 MILITARY MINIATURE SERIES



Tanks appeared first in World War I as an epoch-making new weapon. In the course of time, effective anti-tank weapons were produced one after another by powers of the world. In mid 1930's, anti-tank guns for infantry were developed. These were effective measures especially against light tanks at that time. When fighting against tanks, infantry of those days generally adopted tactics of building a roadblock and shooting and stopping a tank approaching at the head of a tank corps to keep following tanks from advancing. It was the Scout Car that the British Army developed for the main purpose of defending tank corps from such attacks. The main duty that the Scout Car was supposed to do was to go along the expected road of advance far ahead of the tank corps and, when finding an enemy roadblock, move back at a high speed to warn the tank corps of it. Some armour protection of the hull, satisfactory reverse speed and complete manoeuvrability, and four-wheel drive system in view of mobility on rough roads were required to realize the basic plan. The development was started in about 1937 and the first design was submitted by Riley Car Co. which was well known as a motorcar manufacturer. A mock-up was made on the basis of the design at the Army Proving Ground. After various tests made there, it was decided that the crew should be two, armour plates should be added also to the sides and the rear, and the driver seat should be fixed aslant toward the inside so that the driver could easily look back. Manufacturing permit was granted to Riley Car, but this company had already become bankrupt. Instead, Alvis, Ltd. was requested to make a prototype and a prototype called Dingo was completed in March 1938. It was a very small vehicle which mounted an Alvis 4-cylinder 12 hp engine on the rear and had excellent climbing ability.

About the time when the Alvis prototype was completed, a director of B.S.A., manufacturer of motorcycles and front drive cars, visited the War Office. He made an offer to design a new reconnaissance car, which was to compete with the Alvis Dingo. A B.S.A. prototype was completed as early as September 1938. It mounted a 2.5 l engine which was used in the Daimler Limousine, a high-class car of those days, and employed wishbone-type independent suspension with coiled spring for each wheel. The gear box was a special one and the reverse gear had the same gear ratio as the forward gear. The vehicle could move both forward and backward at a maximum speed of about 90 km/h. To make the most of the reverse speed, steering mechanism which could be controlled by a single steering wheel was employed for the front and rear wheels. The driver seat was fixed aslant toward the inside in the same way as the Alvis Dingo so that the driver could easily look back. Thus, the B.S.A. prototype could move backward at the same speed and with the same manoeuvrability as when moving forward. It is needless to say how this point was important considering the original use of the Scout Car. Comparative tests between the B.S.A. prototype and the Alvis Dingo were made at the end of 1938 to January 1939. The former was officially designated Car Scout Mk I and the first mass production order for 52 was placed with B.S.A. Subsequently, B.S.A. was merged into Daimler and the official designation was changed to Car Scout Daimler Mk I. After the decision of the mass production, it was decided that the Scout Car should be used not only in the reconnaissance role but also as a vehicle for com-

munication. As a result, further equipment was added and the weight of the mass production vehicle reached three tons, nearly two times the weight of the prototype. The increase in weight had an evil effect on performance and especially the rear steering became very difficult to control.

At the beginning of 1940, the first mass production vehicle was completed. In April of that year, the Daimler Scout Car was delivered to the 50th Motorcar Division and first saw battle in France. Having excellent speed and satisfactory cross-country ability, the Scout Car was very favorably accepted by fighting units. Two other manufacturers than Daimler, i.e. Humber Motor and Canada Ford, also manufactured their own Scout Cars. The Daimler Scout Car developed into the Mk II and the Mk III. The Scout Car was recognized as a really effective vehicle for reconnaissance and communication on the battlefield.

As mentioned above, the addition of equipment made it very difficult to control the rear steering of the Daimler Scout Car. In about 1941, it joined battle in North African deserts, where the rear steering mechanism was not much needed and was not employed in the Mk II or the Mk III. The Mk III, which appeared at the beginning of 1945, had a commander seat called "jury seat" at the rear of the fighting compartment and the roof was made of canvas. The Mk III was made water proof for the first time and screws fastening the front sand channel were replaced with larger ones. The later Mk III was equipped with smoke shell dischargers.

The Daimler Scout Cars Mk I-III were used by all corps including engineer, artillery, as well as infantry and tank corps, and showed activity in all battlefields until the end of the war. They were still active also after the war and used as the really indispensable "eye" of the corps in all fields of British operations such as Korea, Malaya, Cyprus, Germany and Egypt. The total production of the Mk I-III during World War II reached 6,626.

Essential Specifications of Daimler Scout Car Mk II

| | |
|--------------------------------------|-----------------------|
| Overall length: 3.17 m | Overall width: 1.71 m |
| Overall Height: 1.50 m | |
| Weight: 3.00 t | |
| Armament: One Bren light machine gun | |
| Engine: Daimler 2.5 l engine | |
| Output: 55 hp | |
| Maximum speed: 90 km/h | |
| Crusing range: 320 km/h | |

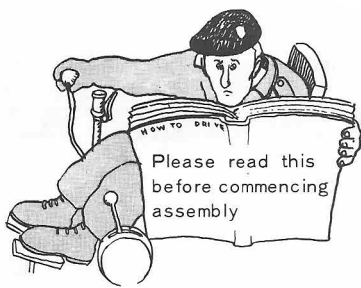

★You will required a pair of tweezers, a file and a sharp hobby knife to build your kit.

★As this kit is composed of fine parts, take good care when removing parts from the plastic sprues.

★Always use glue very sparingly. Too much glue will spoil your finished model.

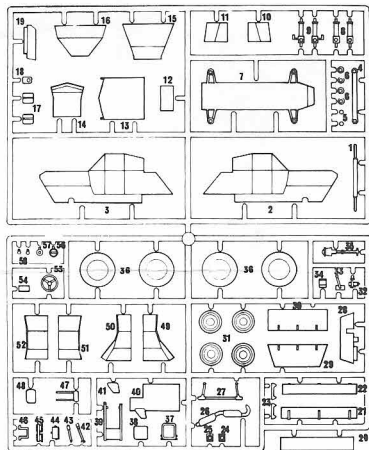

⑤ Construction of Body Rear Fender

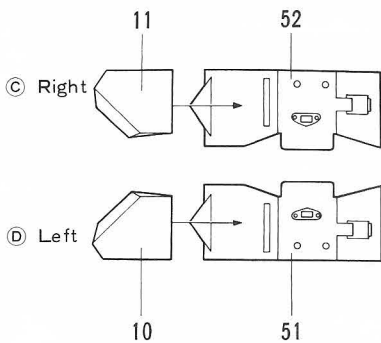

《Assembly of Figures》

Officer

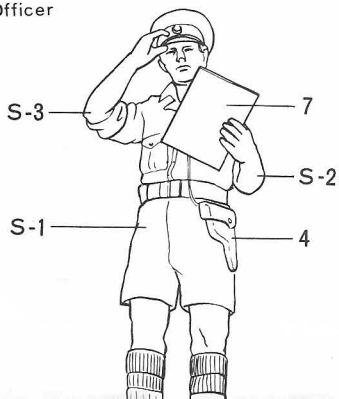

① Construction of Driver's Seat

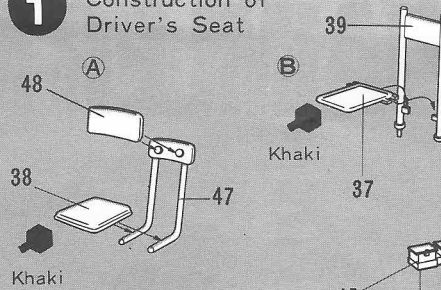

② Installation of Driver's Seat Parts

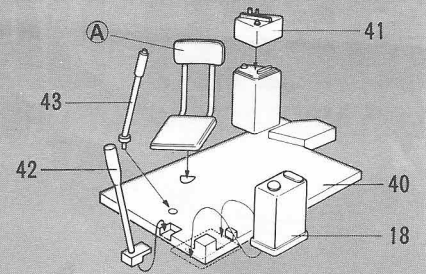

③ Construction of Body (1)

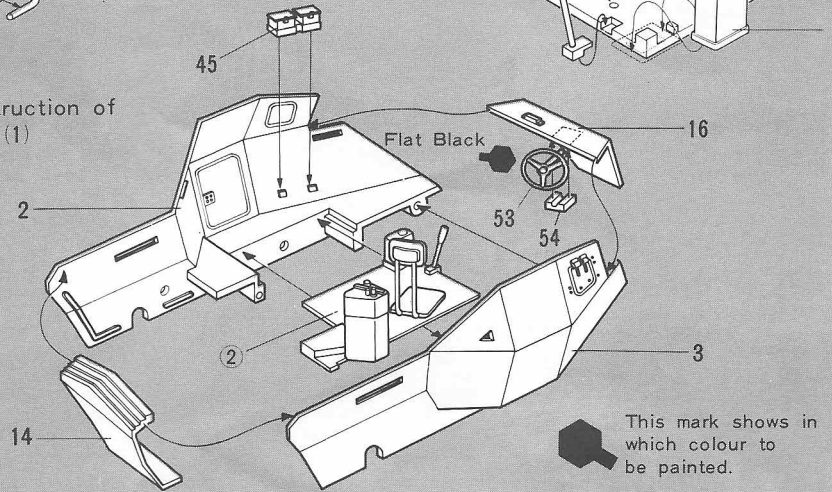

④ Construction of Body (2)

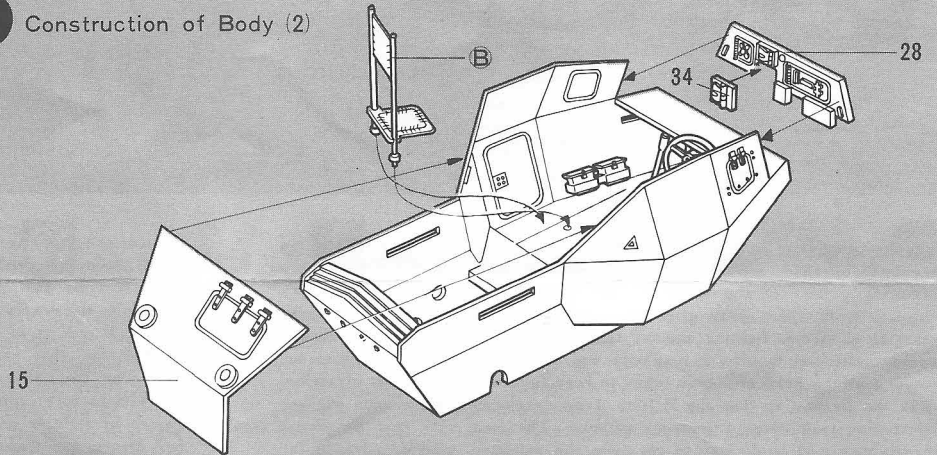

⑤ Construction of Body (3)

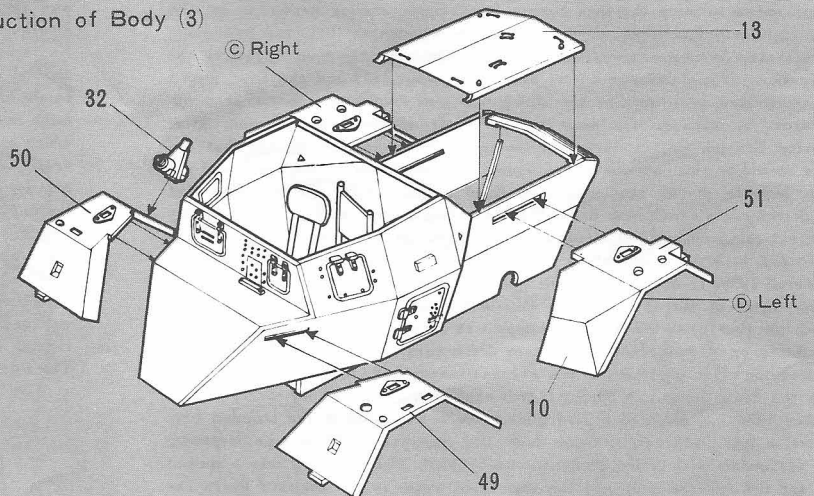

⑥ Assembly of Chassis

When installing tyres, insert Pins (Part No.1 & 5) into Suspension (Part No.8 & 9), do not cement.

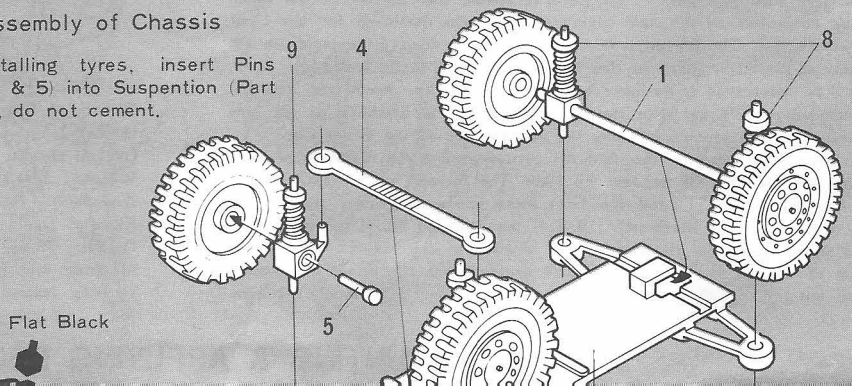

Driver



Infantryman

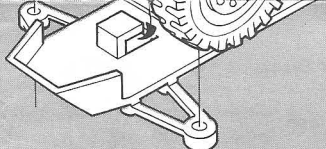
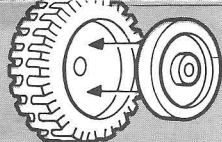
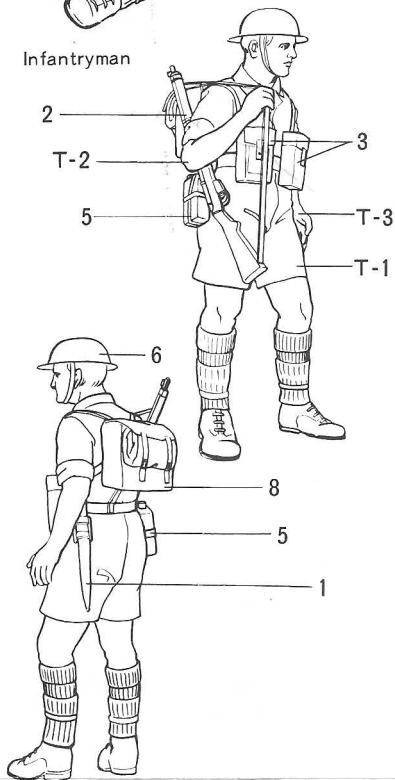

7 Installation of Chassis onto Body

Install Chassis constructed in ⑥ onto Body constructed in ⑤.

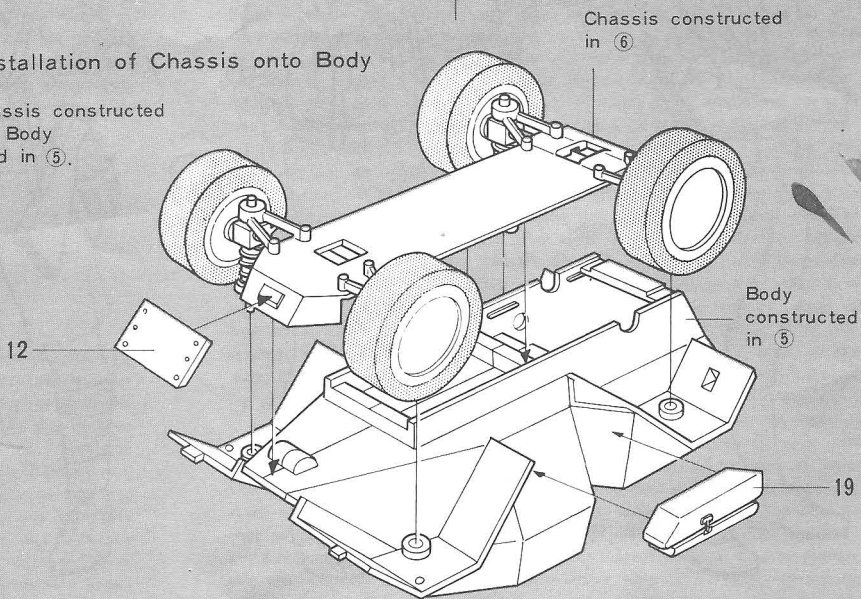

8 Installation of Spare Parts

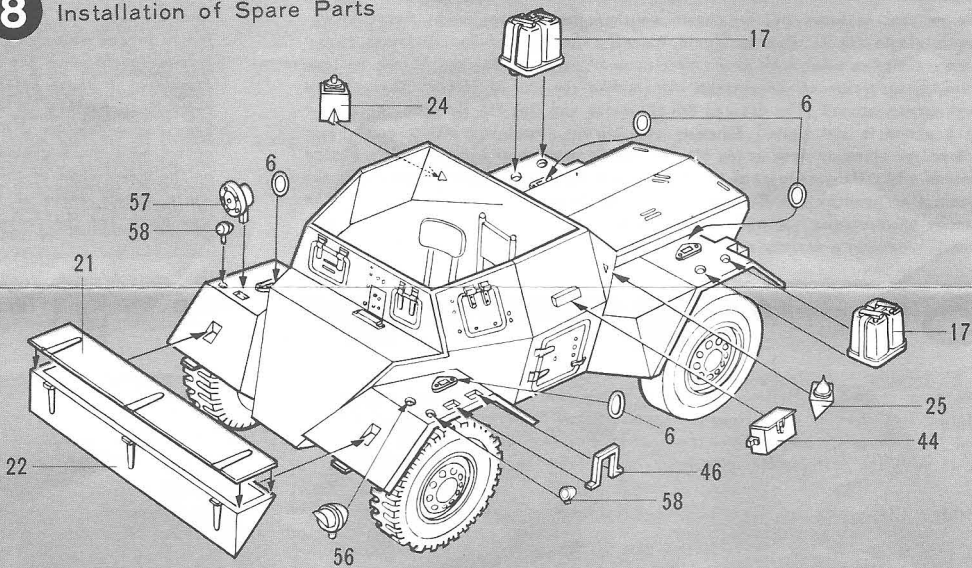

9 Completion of Scout Car

Usually, roofs (Part No.29 & 30) are hardly used.

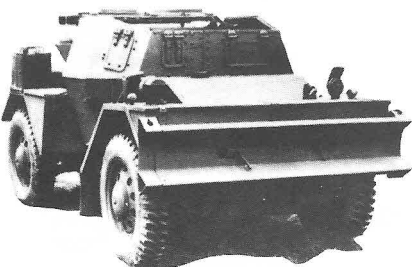
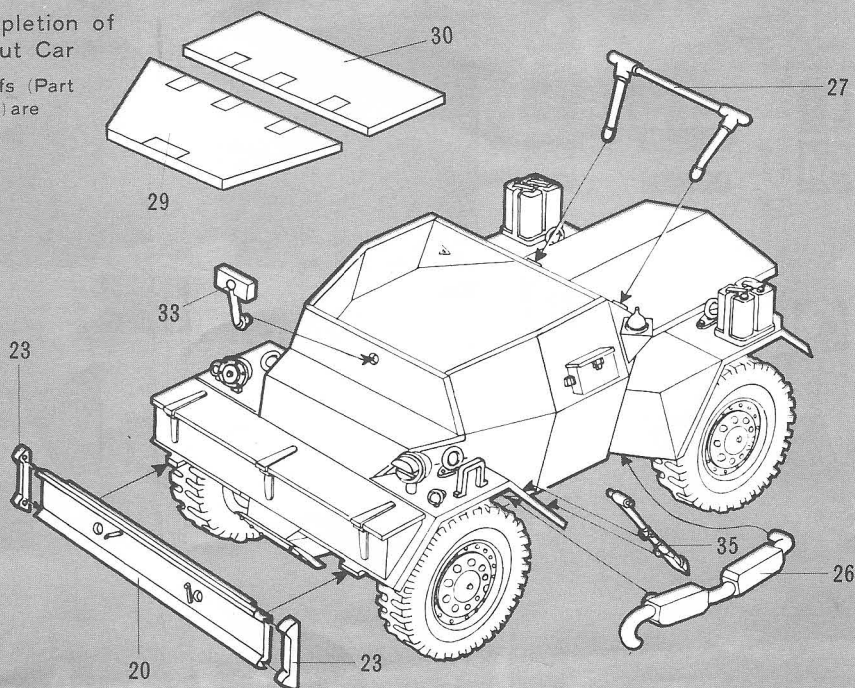

TAMIYA COLOUR CATALOGUE

The latest in cars, boats, tanks and ships. Motorized, radio controlled and museum quality models are all shown in full colour in Tamiya's latest catalogue. At your nearest hobby supply house.

Tamiya Acrylic Paints

Need precise colour matching? Try the new Tamiya acrylic paints. Engineered by modelers for modelers' use. The final cover for the finest models. Insist on Tamiya for perfect results.

Like to detail your models?

Tamiya has a fine line of photo albums that will help you in the super detailing of your tank models or diorama construction. See them at your nearest Tamiya supply house, or order direct from the factory.



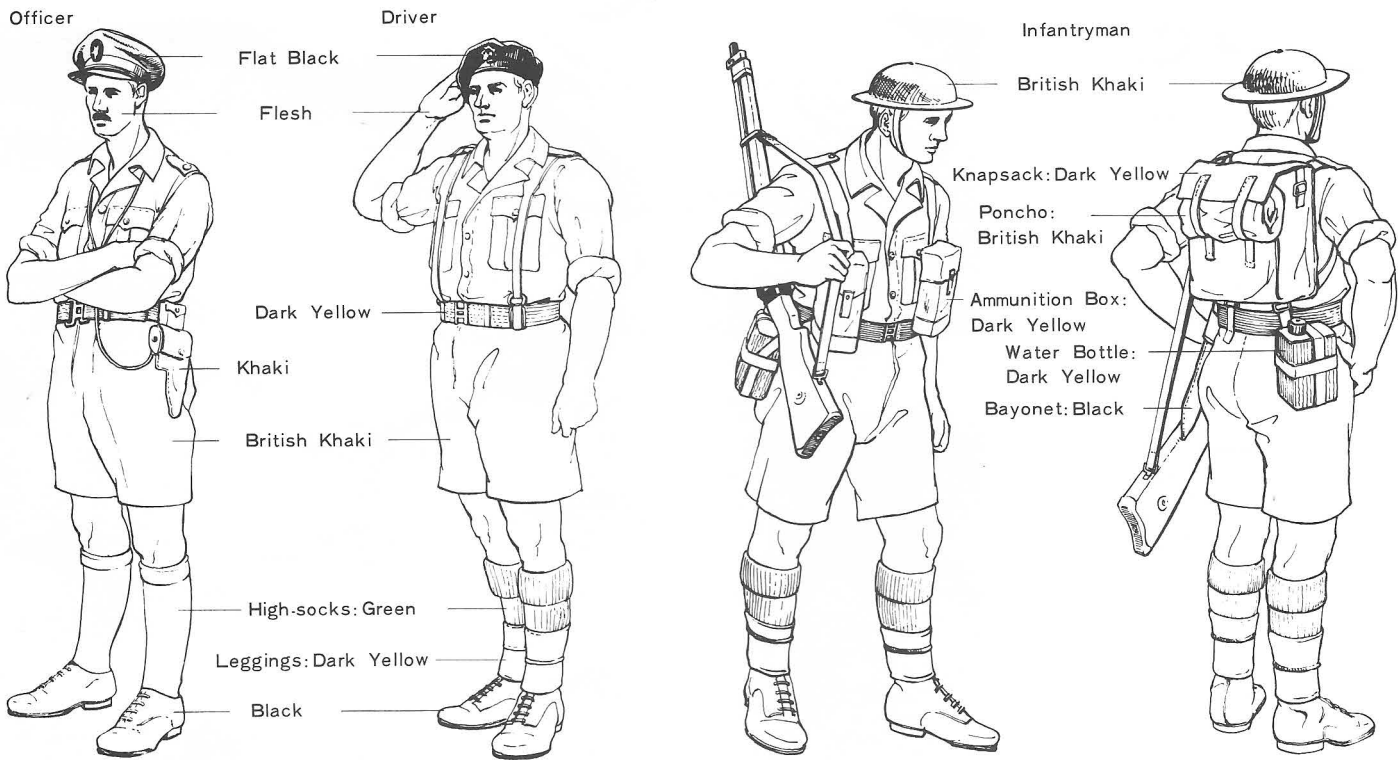

Painting of Scout Car

Military vehicles including the Scout Car used camouflage painting matching the natural features of the region so that the vehicles might merge imperceptibly into them. During World War II, the 1st and 2nd Divisions in the United Kingdom used dark green basic colour or black Mickey Mouse pattern (cloud-shaped camouflage pattern looking like the ear of Mickey Mouse) on a dark green ground. The 6th and 8th Divisions and the 7th Brigade, which use dark green in the United Kingdom and Europe, employed either sand basic colour, or black or dark green Mickey Mouse pattern and ink spots on a sand ground when they were sent to the African front. The above applies to the Scout Car used by the British forces. The Scout Car was also used by the forces of Australia, New Zealand, Canada, India and so on in the Commonwealth, and had a variety of painting. The Australian and New Zealand forces

used either dark green uniform painting or black camouflage pattern on a sand ground. The Canadian forces used dark green uniform painting and the Indian forces whitish sand uniform painting. The Australian and New Zealand forces fought with the Japanese in New Guinea, Guadalcanal and so on and came also to Japan after the war, when many of their Scout Cars had black camouflage pattern on a sand ground. The Australian forces used a white kangaroo design on a blue ground and the New Zealand forces a white fern design on a black ground, which were respectively painted on a plate bolted on the upper right of the front tool box. The inside (driver seat) was painted white, cream white or the same colour as the outside. The steering wheel was black and the seats were covered with Khaki cloth.

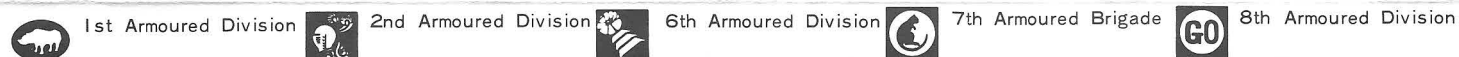

Marking applied to British military vehicles generally consisted of the formation sign showing the division, brigade or the like, the unit sign representing the unit in the corps, and the number meaning the vehicle number. Also used were the bridging classification sign (vehicle weight classification sign

to be used when crossing a bridge, e.g. "3" means three tons and "5" five tons) which was peculiar to Britain as well as nicknames and so on. Choose and apply divisional and unit signs as shown below.

Bridge Classification Sign

- 3
- 5

Unit Number

- 47
- 54

Nickname

- OTRANTA
- DEMON

Unit Sign

- 67

Divisional Sign

- 1st Armoured Division
- 2nd Armoured Division
- 6th Armoured Division
- 7th Armoured Brigade
- 8th Armoured Division (GO)

Vehicle Number

- F17441
- F14828
- F19377

Divisional Sign

- 1st Armoured Division
- 2nd Armoured Division
- 6th Armoured Division
- 7th Armoured Brigade
- 8th Armoured Division (GO)