



Based on the commercial DC-10 airliner, the new KC-10A Extender can be used as a cargo and personnel transport simultaneously with its role as an airborne filling station. The KC-10A is the largest aerial tanker ever placed in service and is capable of refueling most military aircraft, using both the flying boom and probe/drogue methods. In addition, the Extender itself can be refueled from another tanker in flight.

The first KC-10 was delivered to the Strategic Air Command at Barksdale AFB in March, 1981, and the type is now fully operational with SAC. A crew of five operate the huge tanker, and up to

69 mission support personnel can be carried, along with the necessary gear for the maintenance and service of the squadron.

The Extender can carry up to 200,000 lbs. of fuel and 170,000 lbs. of cargo 2,200 miles from its base and return, or escort and refuel a flight of fighters for 4,370 miles.

The F-15 Eagle is an air superiority fighter, designed for USAF's Tactical Air Command. The Eagle entered service in November, 1974, and has been in combat with the Israeli Air Force with notable success. It has also been ordered by Japan and Saudi Arabia.

ENGLISH: ASSEMBLY DRAWINGS SHOULD BE REVIEWED BEFORE PROCEEDING WITH CONSTRUCTION. A NUMBER IDENTIFIES EACH PLASTIC PART FOR YOUR CONVENIENCE. PAINT SMALL PARTS ON RUNNER BEFORE REMOVING. ALLOW PAINT TO DRY THOROUGHLY BEFORE CONTINUING ASSEMBLY OF KIT. SCRAPE CHROME OR PAINT AT AREA TO BE GLUED. WASH PLASTIC IN MILD DETERGENT SOLUTION. RINSE AND LET AIR DRY FOR BETTER PAINT AND DECAL ADHESION.

FRANCAIS: EXAMINER LES SCHEMAS D'ASSEMBLAGE AVANT DE COMMENCER LA CONSTRUCTION. UN NUMERO IDENTIFIE CHAQUE PIECE DE PLASTIQUE POUR PLUS DE FACILITE. PEINDRE LES PETITES PEICES SUR LE SUPPORT AVANT DE LES ENLEVER. LAISSER LA PEINTURE SECHER COMPLETEMENT AVANT DE CONTINUER L'ASSEMBLAGE

DU KIT. GRATTER LE CHROME OU LA PEINTURE SUR LES SURFACE A COLLER. LAVER LE PLASTIQUE DANS UNE SOLUTION DE DETERGENT LEGERE, RINCER ET LAISSER SECHER A L'AIR POUR UNE MEILLEURE ADHERENCE DE LA PEINTURE ET DES DECALS.

ESPAÑOL: DIBUJOS DE ENSAMBLAJE DEBEN SER REPASADOS ANTES DE SEGUIR CON LA CONSTRUCCION. UN NUMERO IDENTIFICA CADA PARTE DEL PLASTICO PARA SU CONVENIENCIA. PINTA PARTES PEQUENAS DEL KIT ANTES DE QUITARLAS. DEJE SECAR BIEN LA PINTURA ANTES DE SEGUIR EL ENSAMBLAJE. RASPE EL CROMO O LA PINTURA DEL SITIO ANTES DE SER PEGADO. LAVE EL PLASTICO EN UNA SOLUCION SUAVE DETERGENTE. ENJUAGUE. Y DEJE SECAR EN EL AIRE PARA MEJOR ADHESION DE LA PINTURA Y CALCOMANIA.



GLUE
COLLE
PEGA



NO GLUE REQUIRED
LA COLLE N'EST PAS NECESSAIRE
NO NECESITA PEGA



DO IT THIS MANY TIMES
LE FAIRE CE NOMBRE DE FOIS
HAGALO ESTA CANTIDAD DE VECES



OPTIONAL
FACULTATIF
OPCIONAL



APPLY DECALS
COLLER LES DECALCOMANIES
APLICAR CALCAS



SHOWN ASSEMBLED
VU ASSEMBLE
MOSTRADO ARMADO



CLEAR
TRANSPARENT
TRANSPARENTE



WHITE
BLANC
BLANCO



SILVER
ARGENT
PLATA

A <	SILVER	ARGENT	PLATA
B <	GRAY	GRIS	GRIS
C <	MATT BLACK	NOIR MAT	NEGRO MATE
D <	MATT OLIVE	OLIVE MAT	MATE VERDE OLIVIA
E <	MATT DARK BLUE	FONCE BLEU MAT	AZUL OSCURO MATE
F <	WHITE	BLANC	BLANCO
G <	STEEL	ACIER	ACERO

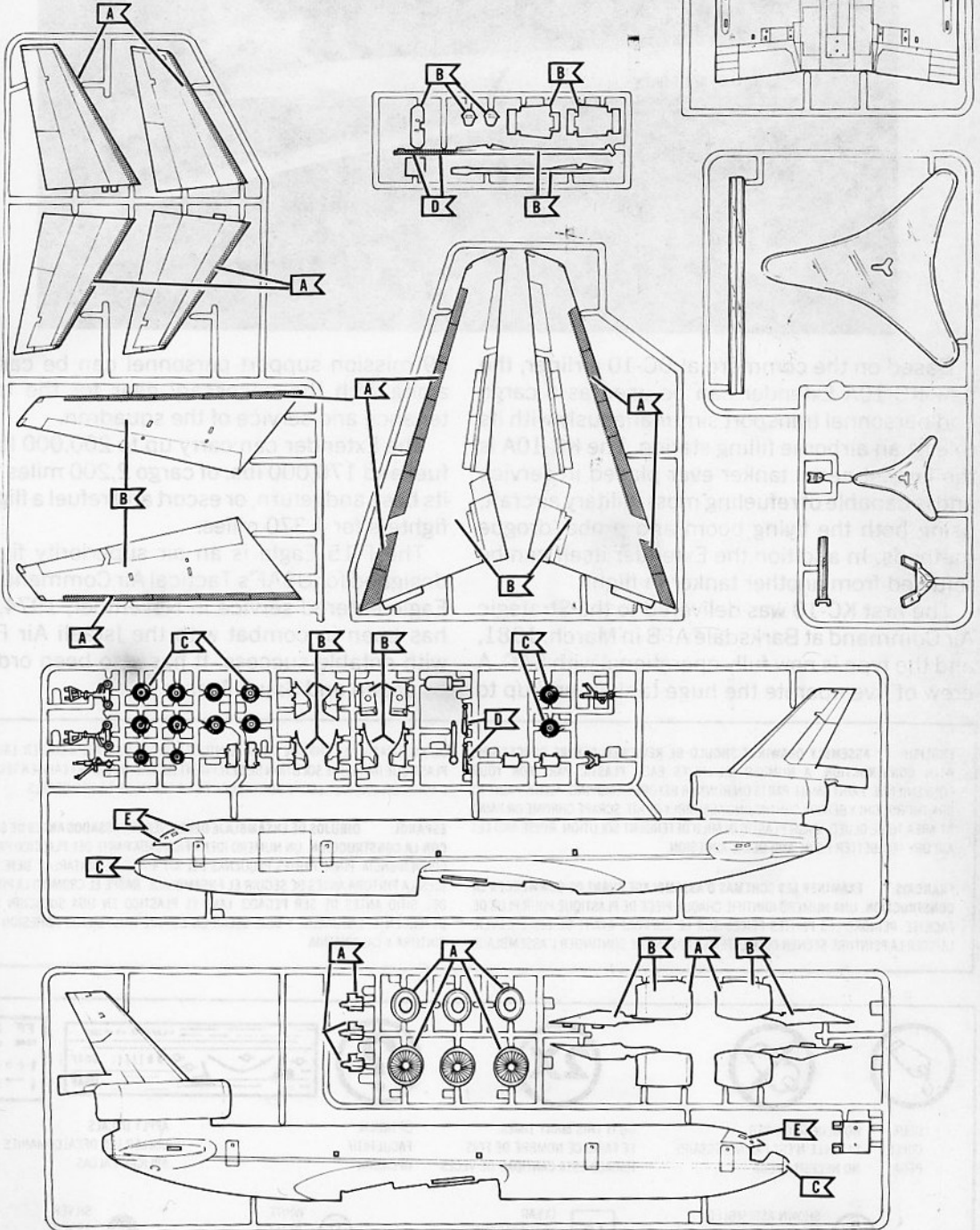

1
60 F-15 SUPPORT POST
61 F-15 BASE
62 SUPPORT PLATE

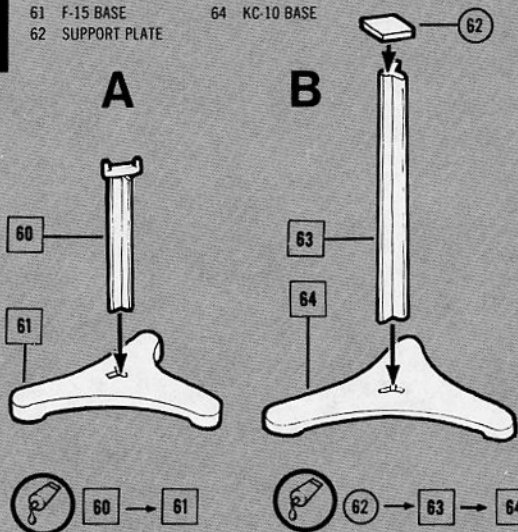

2
12 EXHAUST CONE SEPARATOR (3 PARTS)
13 EXHAUST CONE (3 PARTS)

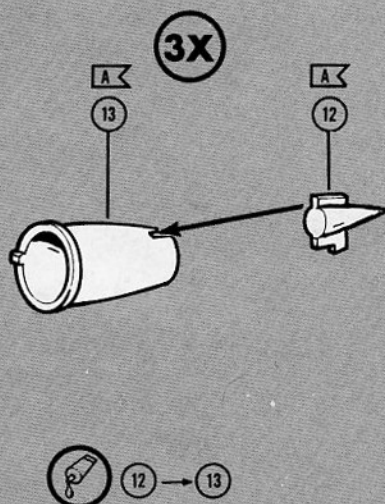

3

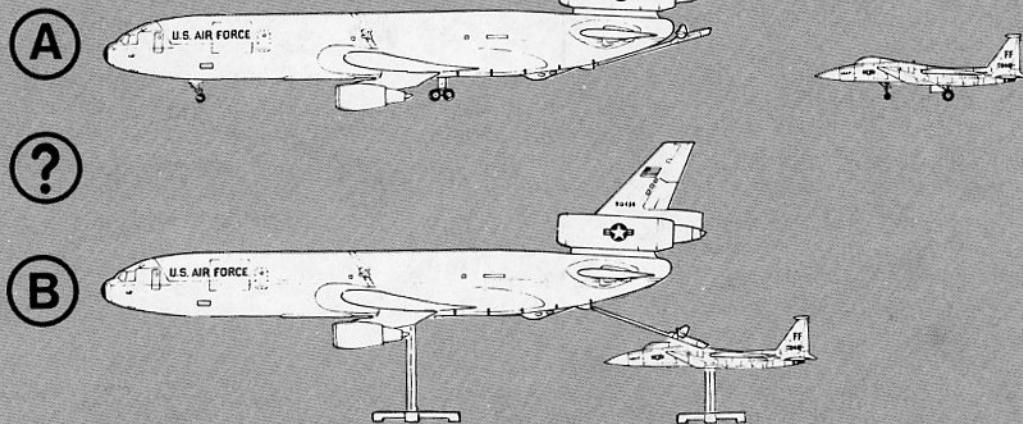

4

A
2 RIGHT FUSELAGE HALF
11 ENGINE FAN
65 MIRROR FAIRING — RAISED

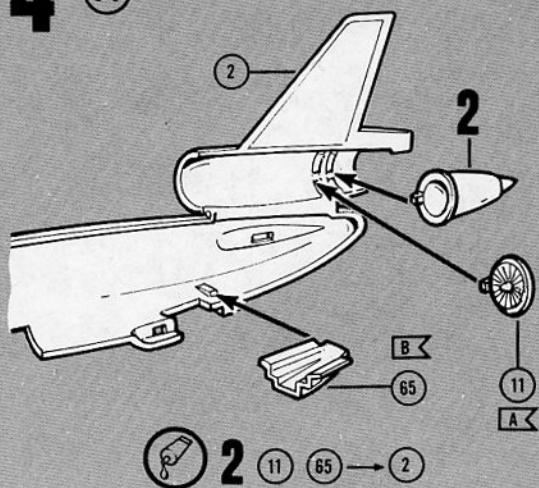

5

B
2 RIGHT FUSELAGE HALF
11 ENGINE FAN
66 MIRROR FAIRING — LOWERED
67 OPERATOR WINDOW

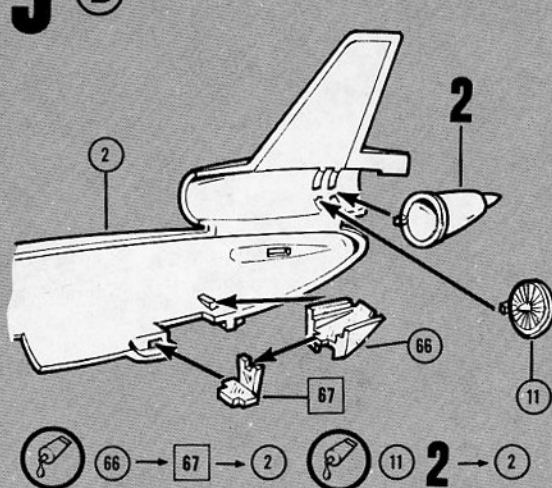

6

- 1 LEFT FUSELAGE
- 10 NOSE GEAR PLATFORM
- 14 WINDSHIELD (CLEAR)

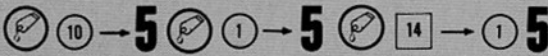
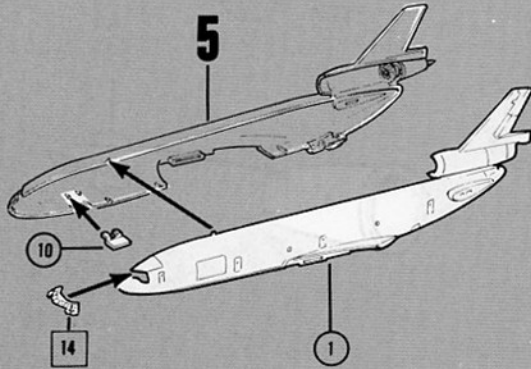

7

- 17 ENGINE FAN
- 18 ENGINE COWLING-OUTBOARD
- 19 ENGINE COWLING-INBOARD
- 22 ENGINE FAN
- 23 ENGINE COWLING-OUTBOARD
- 24 ENGINE COWLING-INBOARD

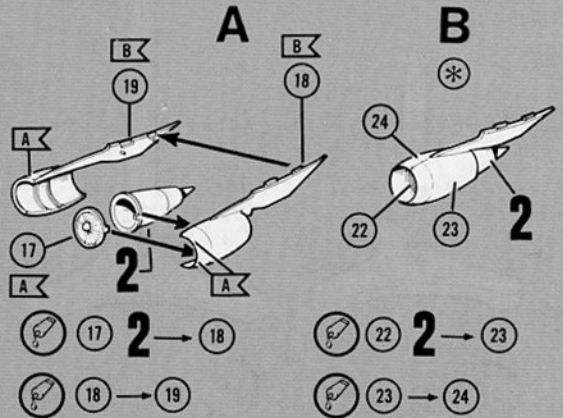

8

- 25 LEFT WING — TOP
- 26 RIGHT WING — TOP
- 28 LEFT WING — LOWER
- 29 RIGHT WING — LOWER

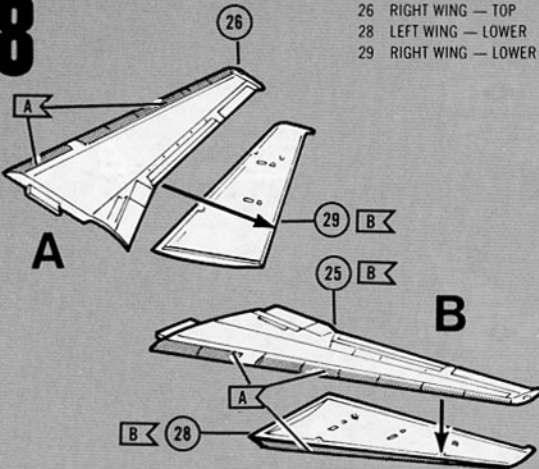

9

- 30 LEFT STABILIZER — TOP
- 31 LEFT STABILIZER — BOTTOM
- 32 RIGHT STABILIZER — TOP
- 33 RIGHT STABILIZER — BOTTOM

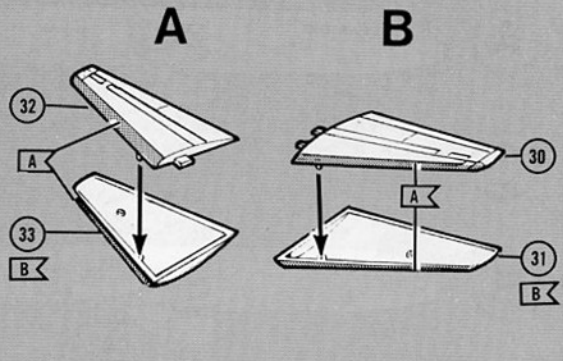

10

- 27 CENTER WING — LOWER SECTION

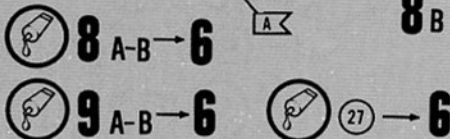
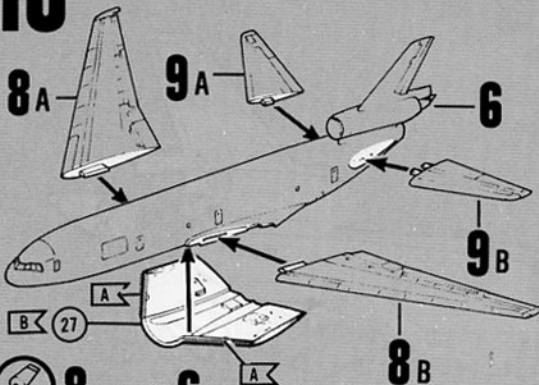

11

- 34 LEFT FLAP HINGE — INBOARD
- 35 LEFT FLAP HINGE — CENTER
- 36 LEFT FLAP HINGE — OUTBOARD
- 37 RIGHT FLAP HINGE — INBOARD
- 38 RIGHT FLAP HINGE — CENTER
- 39 RIGHT FLAP HINGE — OUTBOARD

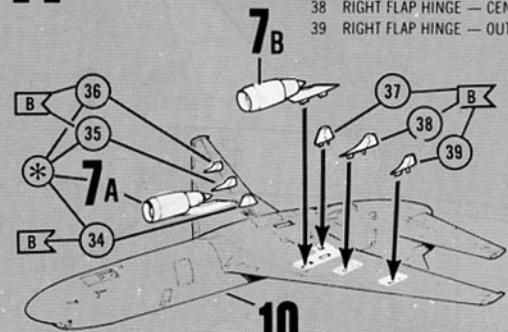

12 (B)

- 43 RIGHT MAIN GEAR DOOR
- 47 LEFT MAIN GEAR DOOR
- 49 NOSE WHEEL DOOR L.H.
- 50 NOSE WHEEL DOOR R.H.

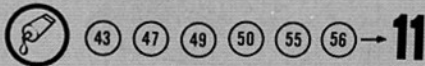
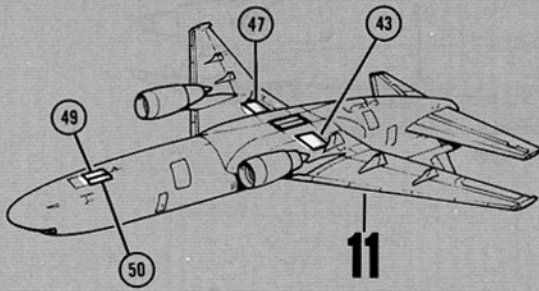

13 (A)

- 40 NOSE GEAR STRUT
- 41 NOSE WHEEL WITH AXLE
- 42 NOSE WHEEL

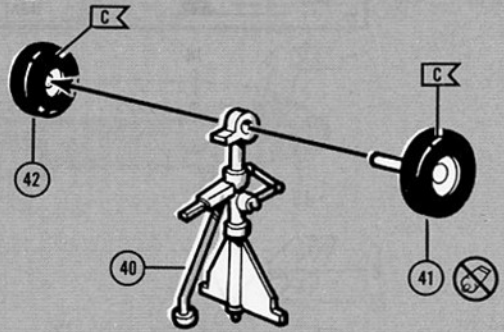

14

- 49 NOSE WHEEL DOOR L.H.
- 50 NOSE WHEEL DOOR R.H.

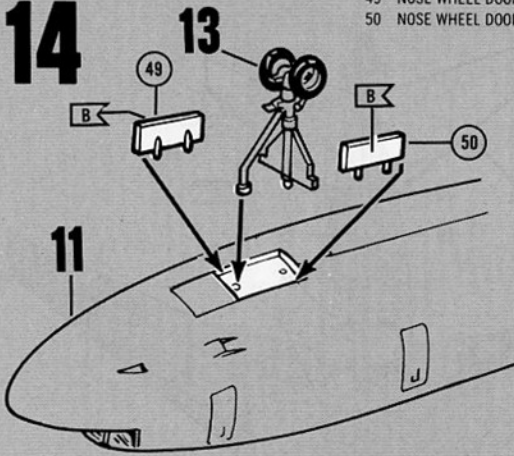

15

- 44 RIGHT MAIN GEAR STRUT
- 45 WHEEL WITH AXLE (4 PARTS)
- 46 WHEEL (4 PARTS)
- 48 LEFT MAIN GEAR STRUT

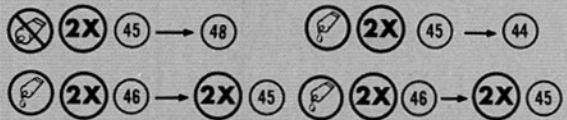
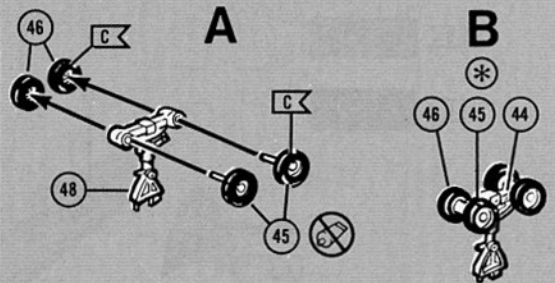

16

- 52 CENTER GEAR STRUT
- 53 CENTER GEAR STRUT BRACE
- 54 WHEEL WITH AXEL
- 55 CENTER GEAR DOOR — LEFT
- 56 CENTER GEAR DOOR — RIGHT
- 43 RIGHT MAIN GEAR DOOR
- 47 LEFT MAIN GEAR DOOR
- 51 GEAR RETRACT LINK (2 PARTS)

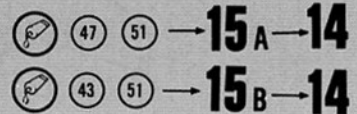
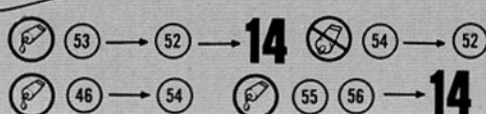
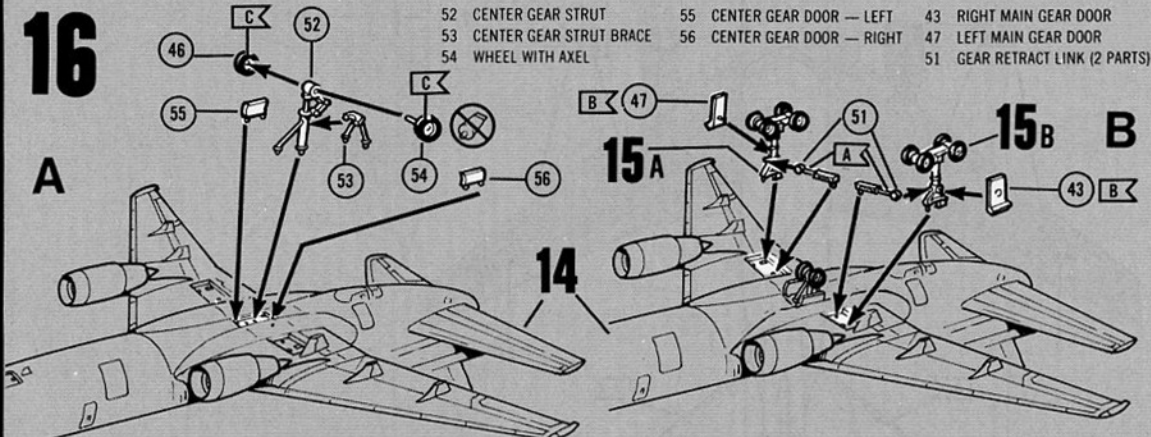

17

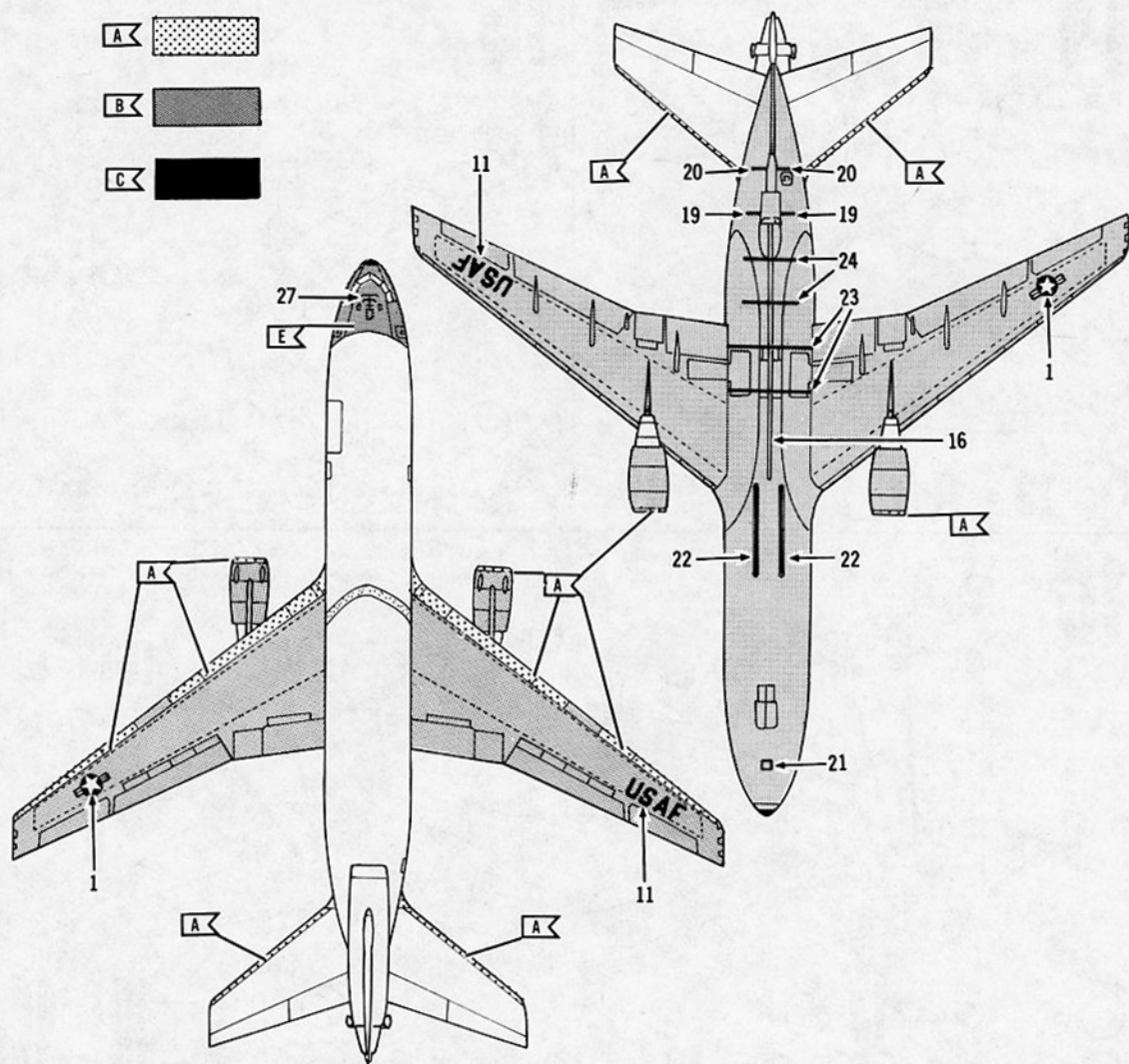
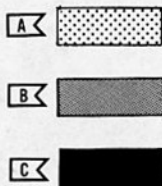
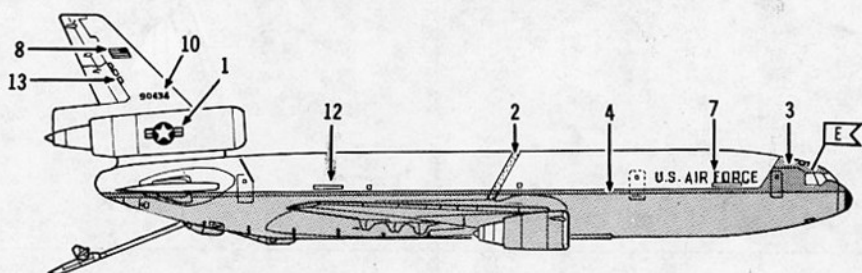
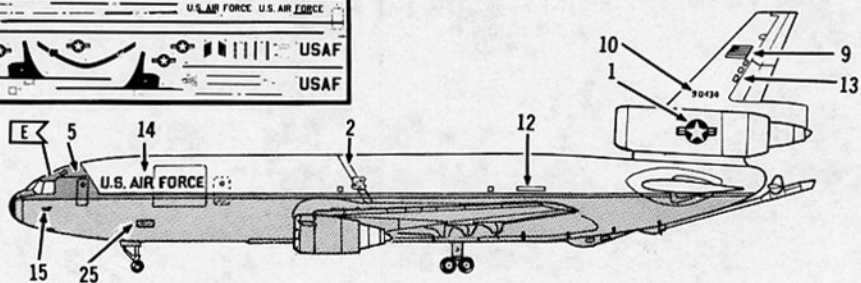

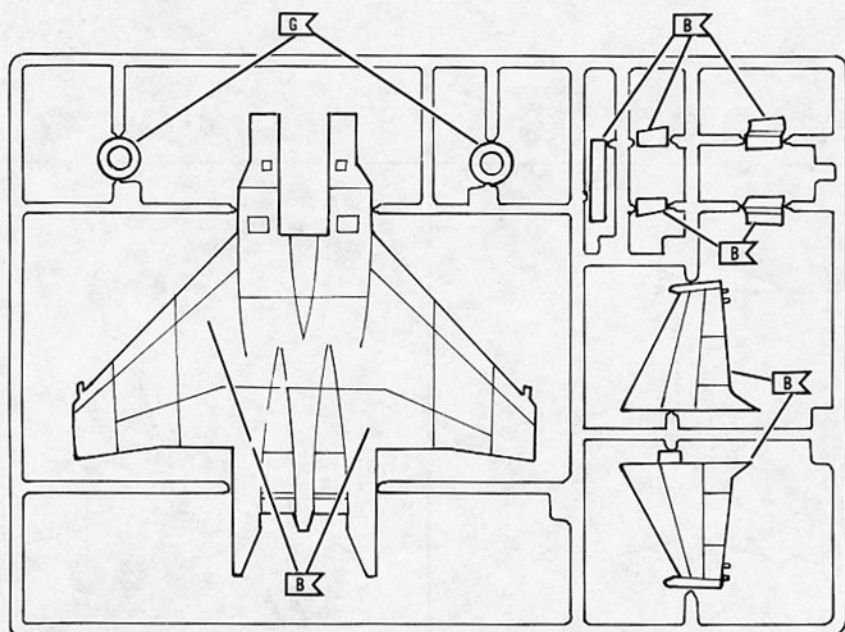
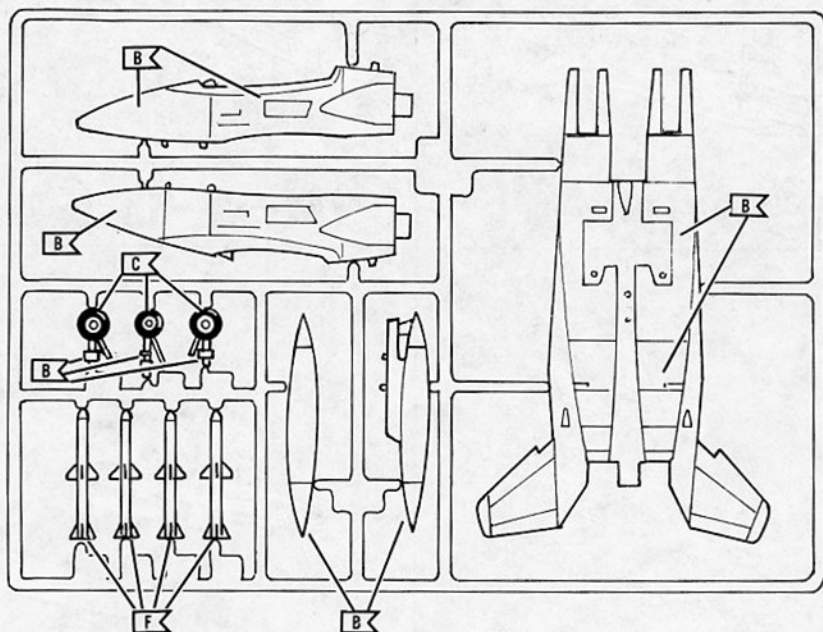
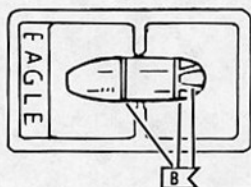
18

- 1 FUSELAGE — TOP HALF
2 FUSELAGE — BOTTOM HALF

**19**

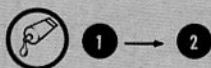
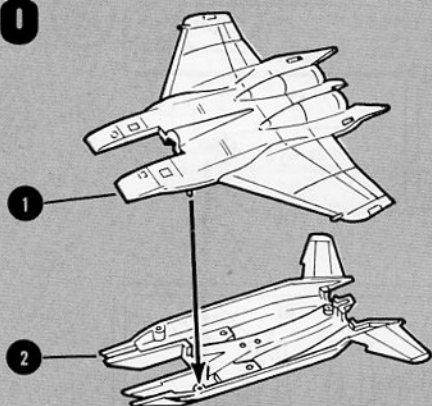
- 3 NOSE — LEFT HALF
4 NOSE — RIGHT HALF

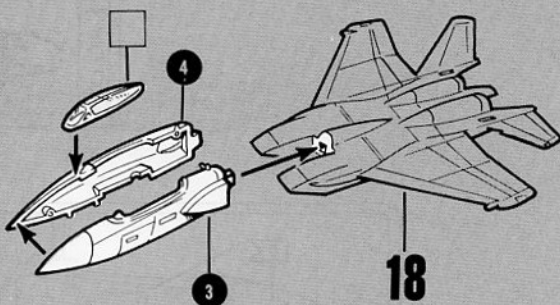
**20**

- 11 RUDDER — RIGHT
12 RUDDER — LEFT
18 EXHAUST CONES (2 PARTS)

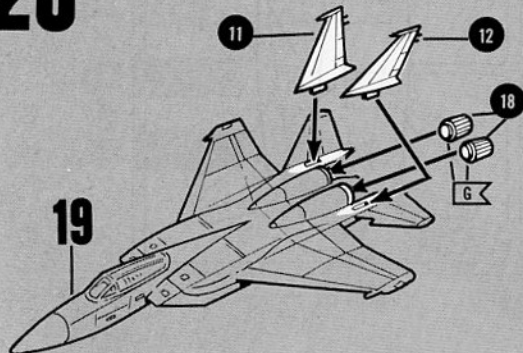
**21**

- 5 FUEL TANK — RIGHT HALF
6 FUEL TANK — LEFT HALF

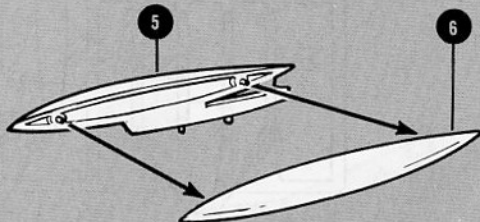
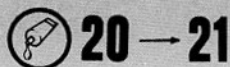
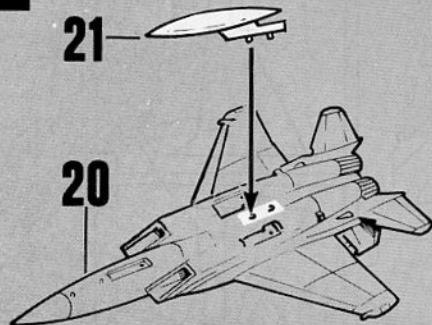
**22****23**

- 13 LEFT MAINGEAR DOOR FRONT 16 LEFT MAINGEAR DOOR BACK
14 RIGHT MAINGEAR DOOR FRONT 17 NOSEWHEEL DOOR
15 RIGHT MAINGEAR DOOR BACK

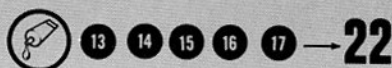
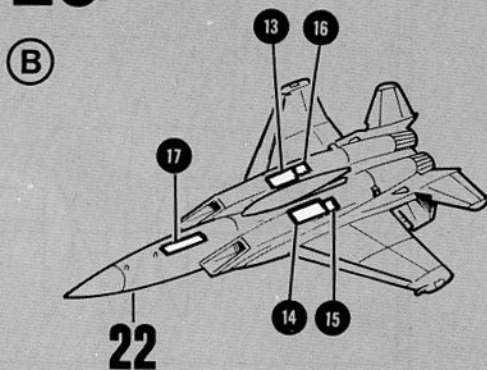

24

- 8 NOSE LANDING GEAR
- 17 NOSEWHEEL DOOR

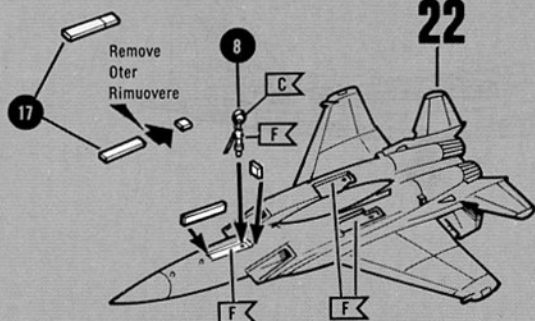

25

- 7 LEFT MAIN LANDING GEAR
- 13 LEFT MAINGEAR DOOR FRONT
- 16 LEFT MAINGEAR DOOR BACK

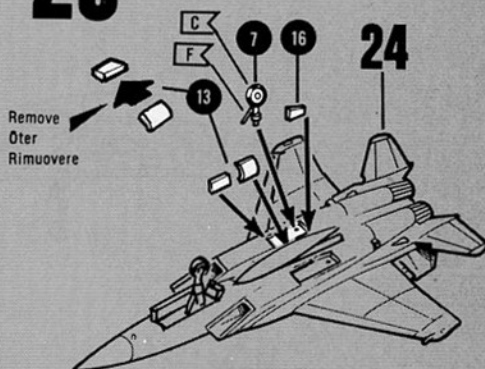

26

- 9 RIGHT MAIN LANDING GEAR
- 14 RIGHT MAINGEAR DOOR FRONT
- 15 RIGHT MAINGEAR DOOR BACK

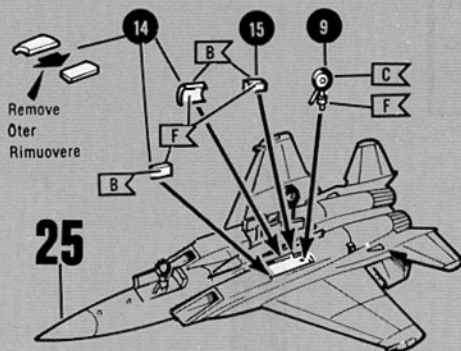

27

- 10 AIR-TO-AIR SPARROW MISSILES (4 PARTS)

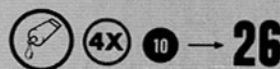
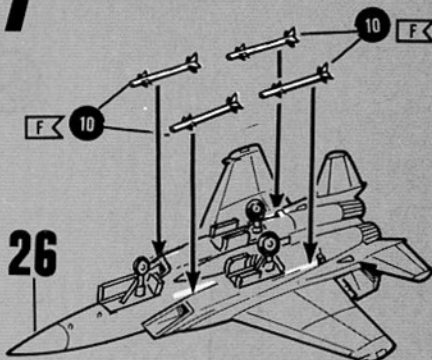

28

- 67 BOOM VERTICAL STABILIZER — RIGHT
- 68 BOOM VERTICAL STABILIZER — LEFT
- 69 BOOM HORIZONTAL STABILIZER
- 70 AERIAL REFUELING BOOM — EXTENDED
- 71 AERIAL REFUELING BOOM — RETRACTED

