

REICHsverTEIDIGUNG

Fw 190A-8/R2 & Bf 109G-6/14



1/48

LIMITED EDITION DUAL COMBO

eduard

11119 - NAV1

Fw 190A-8/R2

ATTENTION *

UPOZORNĚNÍ *

ACHTUNG *

ATTENTION *

注意



Carefully read instruction sheet before assembling. When you use glue or paint, do not use near open flame and use in well ventilated room. Keep out of reach of small children. Children must not be allowed to suck any part, or pull vinyl bag over the head.



Před započetím stavby si pečlivě prostudujte stavební návod. Při používání barev a lepidel pracujte v dobře větrané místnosti. Lepidla ani barvy nepoužívejte v blízkosti otevřeného ohně. Model není určen malým dětem, mohlo by dojít k požití drobných dílů.

INSTRUCTION SIGNS * INSTR. SYMBOL * INSTRUKTION SINNBILDEN * SYMBOLES * 記号の説明



OPTIONAL
VOLBA



BEND
OHNOUT



OPEN HOLE
VYVRTAT OTVOR



SYMETRICAL ASSEMBLY
SYMETRICKÁ MONTÁŽ



REMOVE
ODRÍZNOUT



REVERSE SIDE
OTOČIT



APPLY EDUARD MASK
AND PAINT
POUŽIT EDUARD MASK
NABARVIT

PARTS *

DÍLY *

TEILE *

PIÈCES *

部品

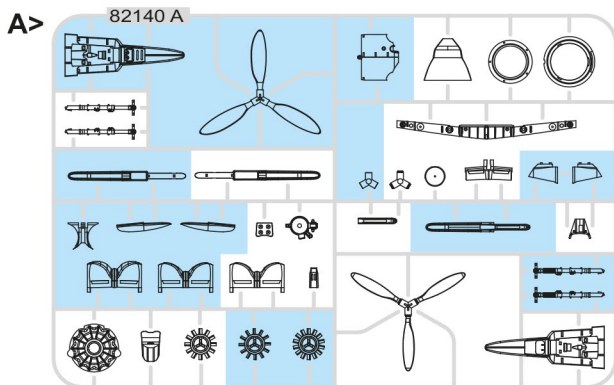

PLASTIC PARTS

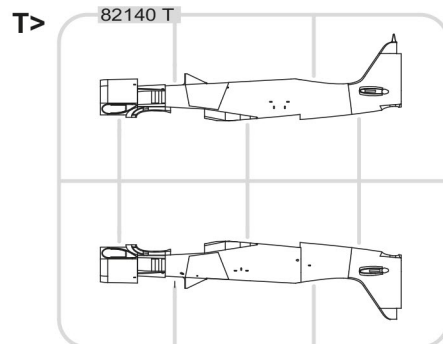
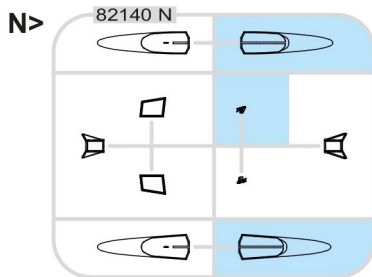
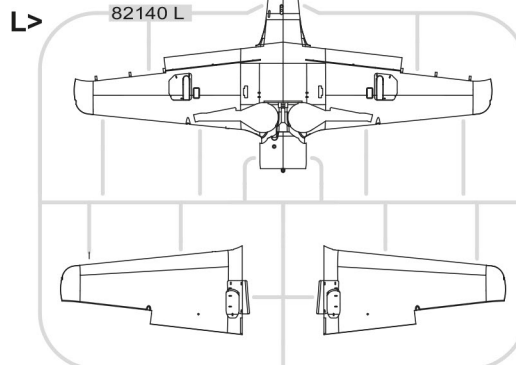
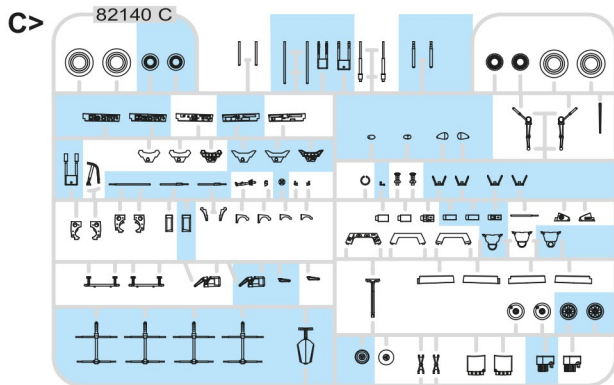
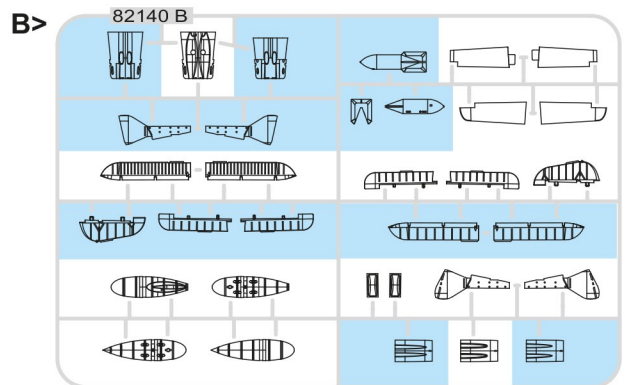

PE - PHOTO ETCHED DETAIL PARTS

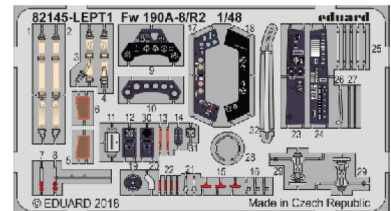

-Parts not for use. -Teile werden nicht verwendet. -Pièces à ne pas utiliser. -Tyto díly nepoužívejte při stavbě. - 使用しない部品

COLOURS *

BARVY *

FARBEN *

PEINTURE *

色

GSI Creos (GUNZE)		MISSION MODELS	
AQUEOUS	Mr.COLOR	PAINTS	
H1	C1	MMP-001	WHITE
H2	C2	MMP-047	BLACK
H5	C5	MMP-048	BLUE
H11	C62	MMP-001	FLAT WHITE
H12	C33	MMP-047	FLAT BLACK
H15	C65		BRIGHT BLUE
H33	C81		RUSSET
H47	C41	MMP-012	RED BROWN
H65	C18	MMP-088	RLM70 BLACK GREEN
H68	C36	MMP-049	RLM74 DARK GRAY
H69	C37	MMP-050	RLM75 GRAY
H70	C60	MMP-056	RLM02 GRAY

GSI Creos (GUNZE)		MISSION MODELS	
AQUEOUS	Mr.COLOR	PAINTS	
H77	C137	MMP-040	TIRE BLACK
H90	C47		CLEAR RED
H94	C138		CLEAR GREEN
H413	C113	MMP-090	RLM04 YELLOW
H414	C114		RLM23 RED
H416	C116	MMP-089	RLM66 BLACK GRAY
H417	C117	MMP-051	RLM76 LIGHT BLUE
Mr.METAL COLOR		METALLICS	
MC213		MMM-006	STEEL
MC214		MMM-001	DARK IRON
Mr.COLOR SUPER METALLIC		METALLICS	
SM01		MMC-001	SUPER CHROME

A

PE24

C71

H416/MMP
C116 089
RLM 66
BLACK GRAY

decal 68

C75

H416/MMP
C116 089
RLM 66
BLACK GRAY

C20

H416/MMP
C116 089
RLM 66
BLACK GRAY

C59

C43

PE14

C60

C45

B

C41

PE20

H416/MMP
C116 089
RLM 66
BLACK GRAY

PE23

C72

H416/MMP
C116 089
RLM 66
BLACK GRAY

decal 67

C77

H416/MMP
C116 089
RLM 66
BLACK GRAY

C15

H416/MMP
C116 089
RLM 66
BLACK GRAY

C39

H2 MMP
C2 047
BLACK

A34

H416/MMP
C116 089
RLM 66
BLACK GRAY

A38

H416/MMP
C116 089
RLM 66
BLACK GRAY

PE13

H416/MMP
C116 089
RLM 66
BLACK GRAY

ball pen

PE11

A38

H416/MMP
C116 089
RLM 66
BLACK GRAY

C39

H2 MMP
C2 047
BLACK

A38

H416/MMP
C116 089
RLM 66
BLACK GRAY

A38

H416/MMP
C116 089
RLM 66
BLACK GRAY

A38

H416/MMP
C116 089
RLM 66
BLACK GRAY

C

PE7

C67

H416/MMP
C116 089
RLM 66
BLACK GRAY

PE18

C70

PE15

PE17

PE12

C48

H416/MMP
C116 089
RLM 66
BLACK GRAY

decal 63

C69

PE15

C50

H416/MMP
C116 089
RLM 66
BLACK GRAY

D

2 pcs.

PE29

PE3

PE6

A14

H47 MMP
C41 012
RED BROWN

H416/MMP
C116 089
RLM 66
BLACK GRAY

A28

PE1

PE2

PE4

PE5

C49

H416/MMP
C116 089
RLM 66
BLACK GRAY

C49

PE1

PE2

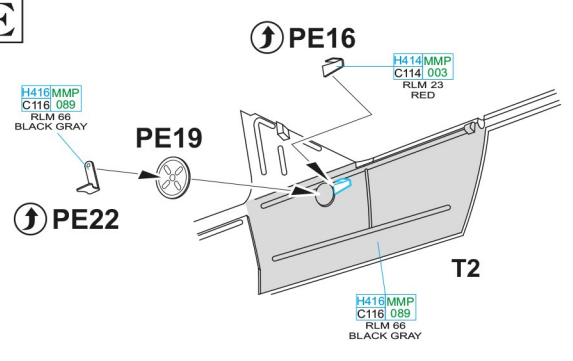
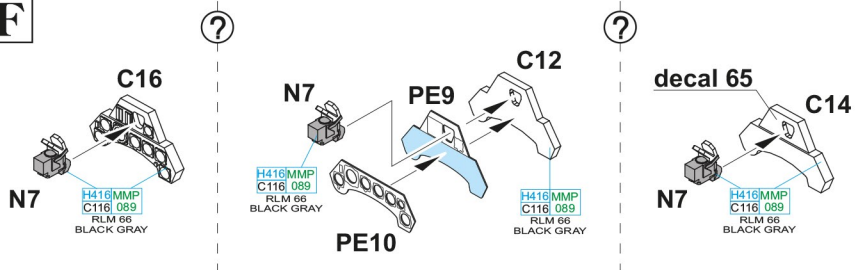
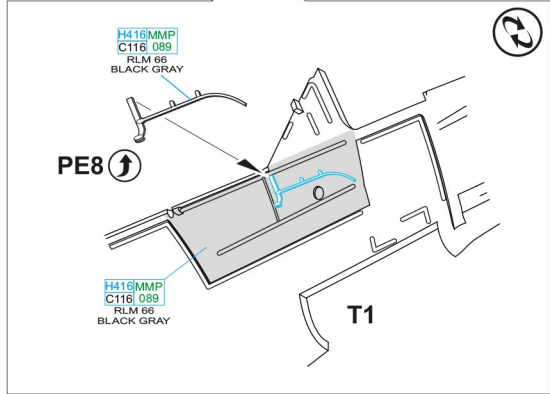
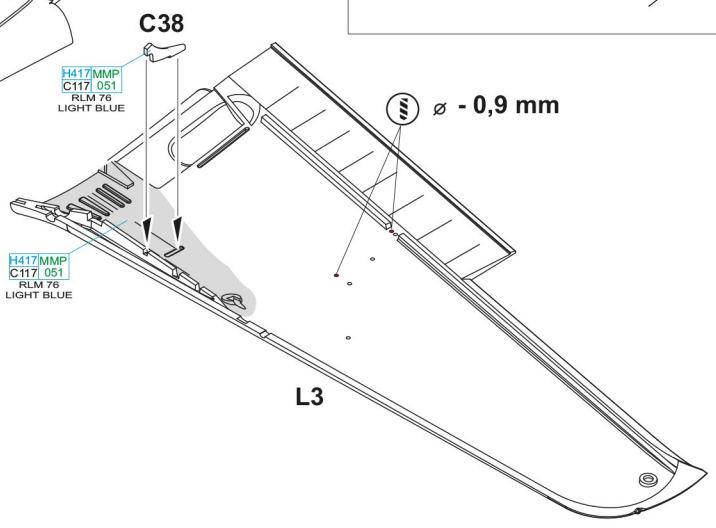
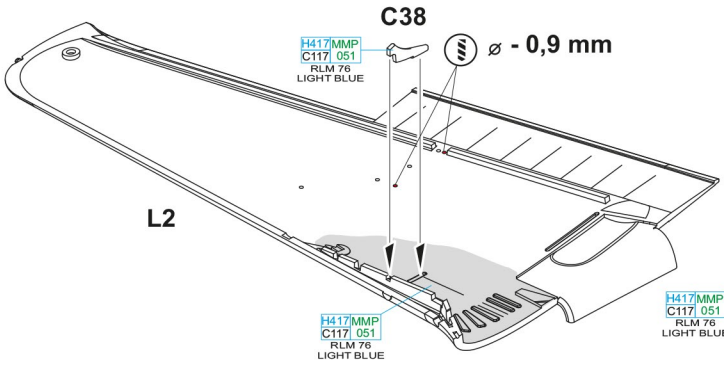
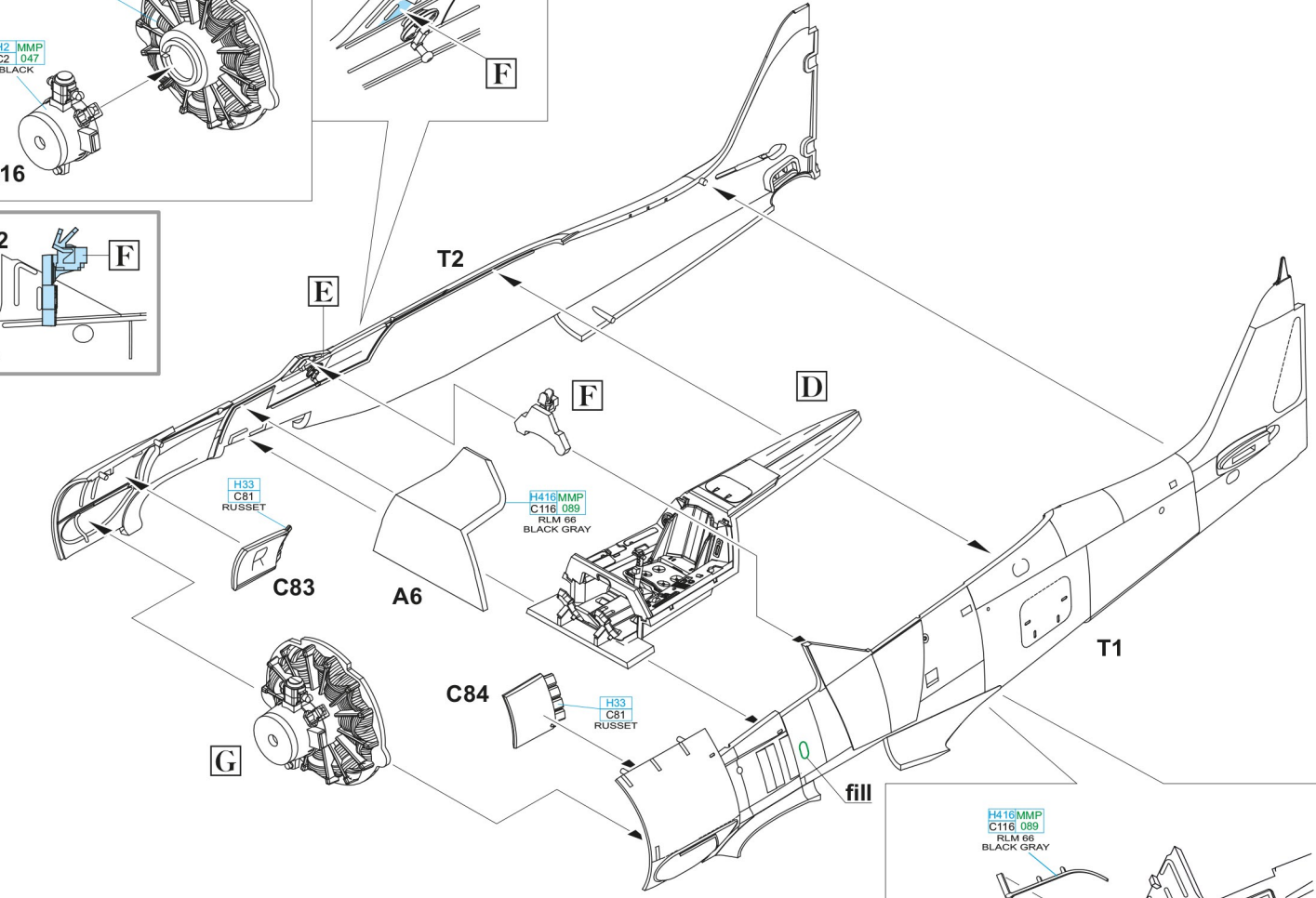
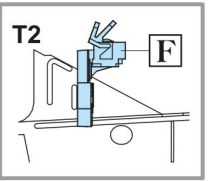
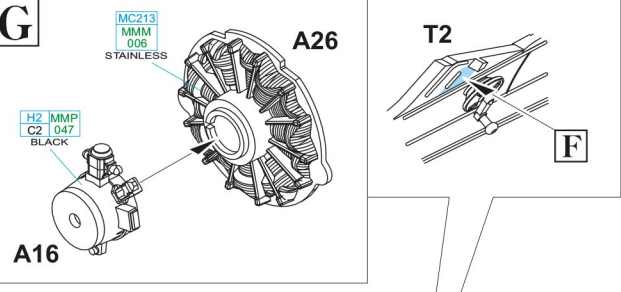
E**F****G**

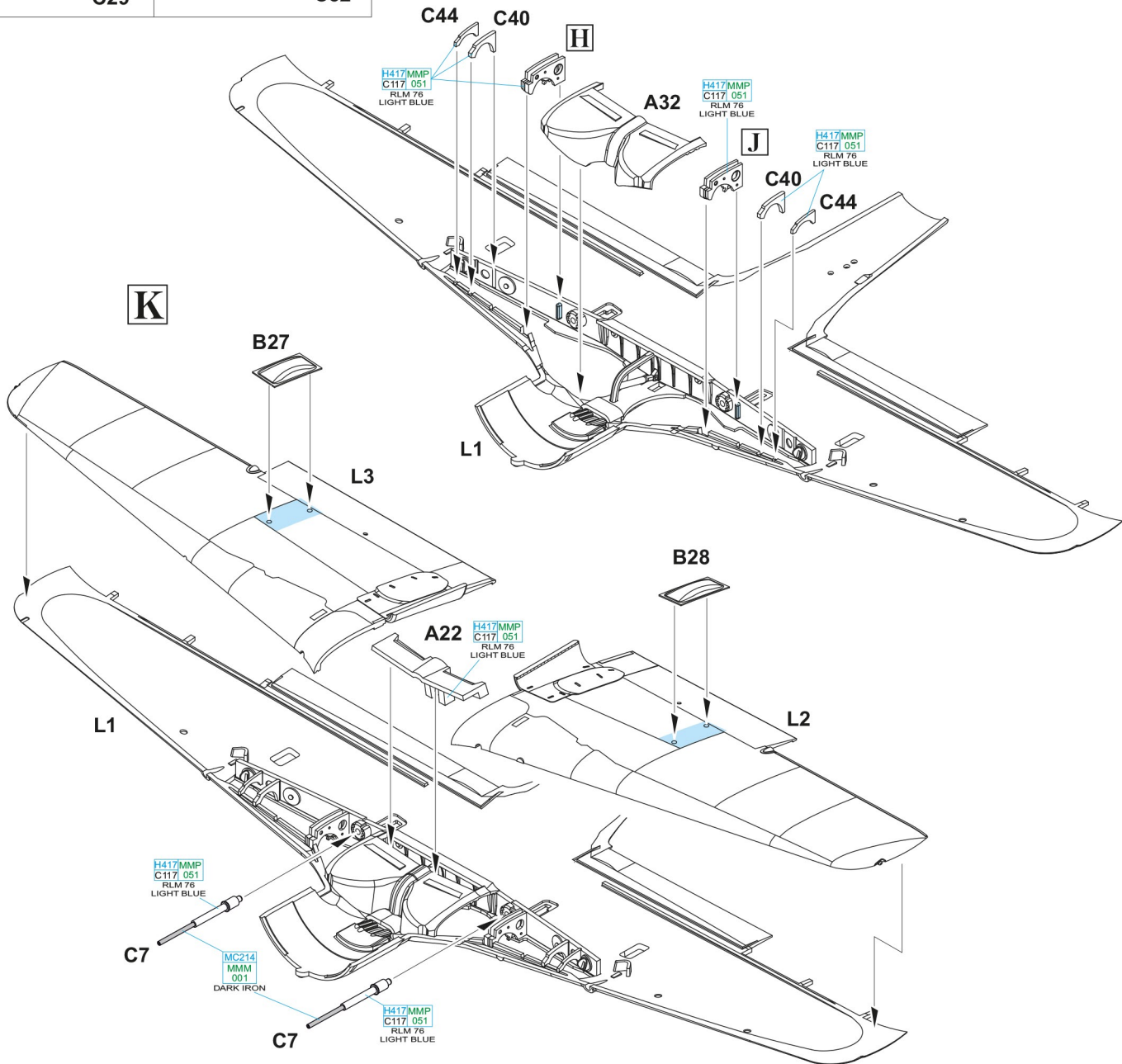
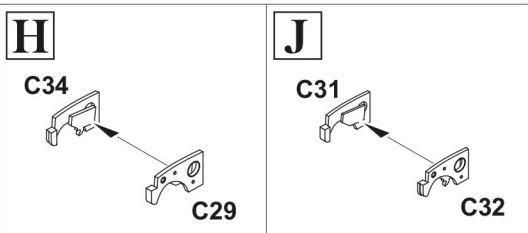
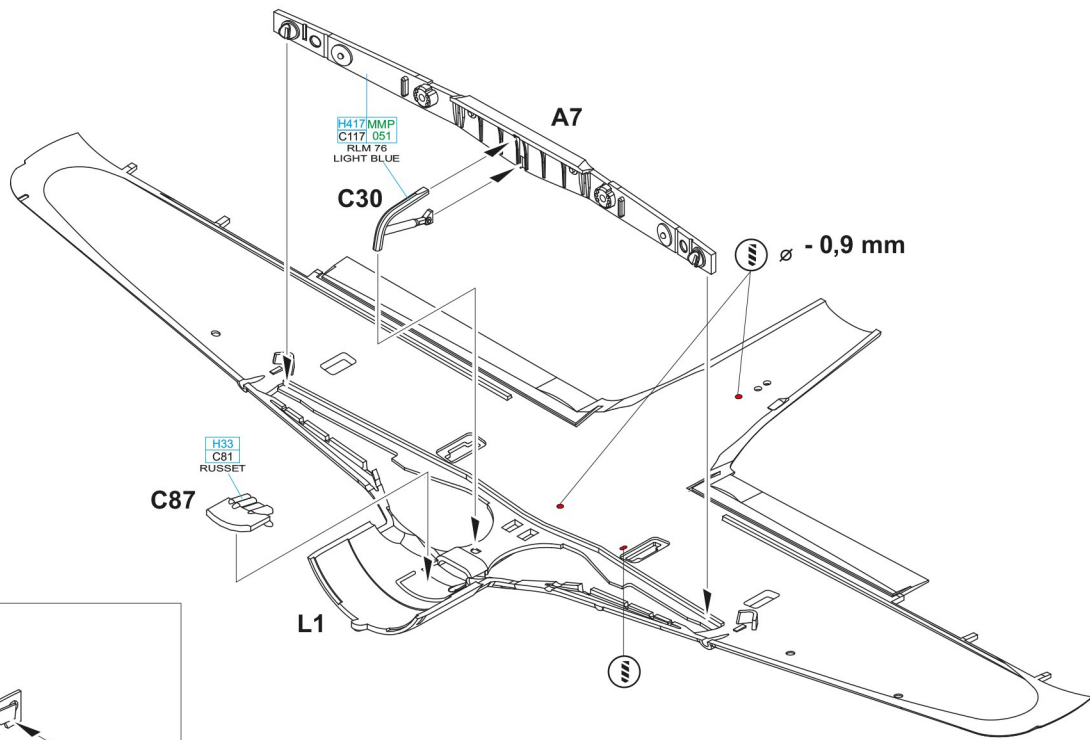

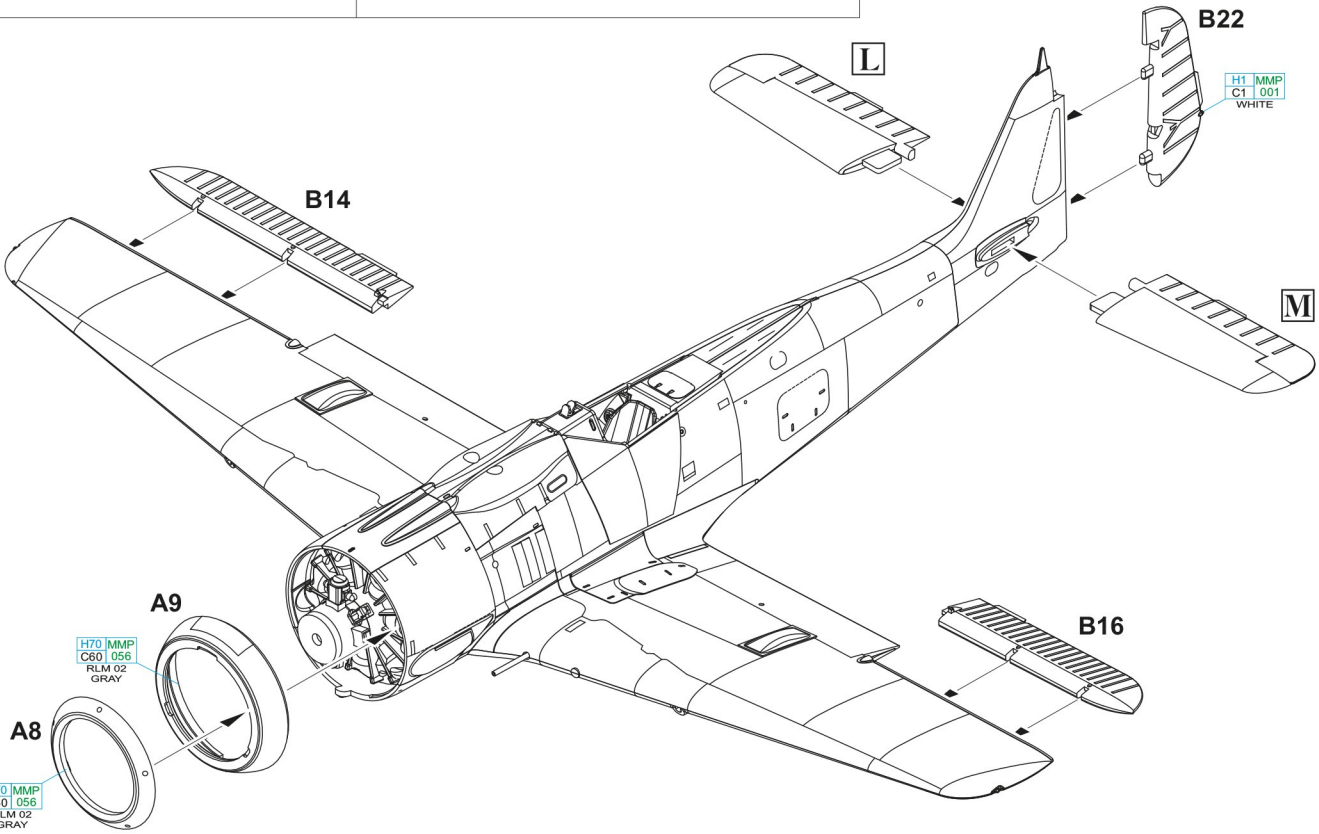
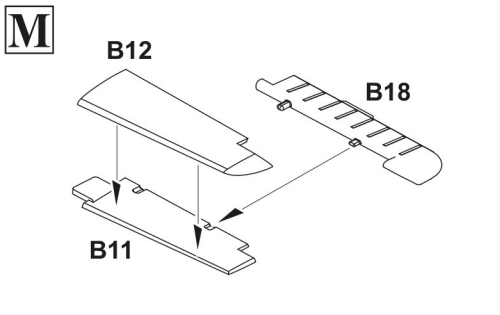
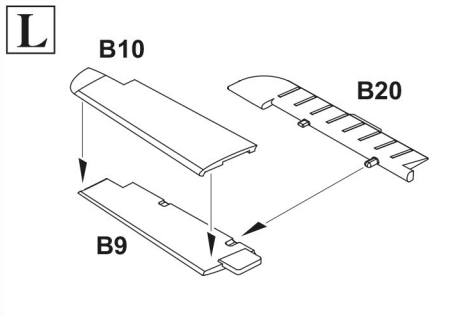
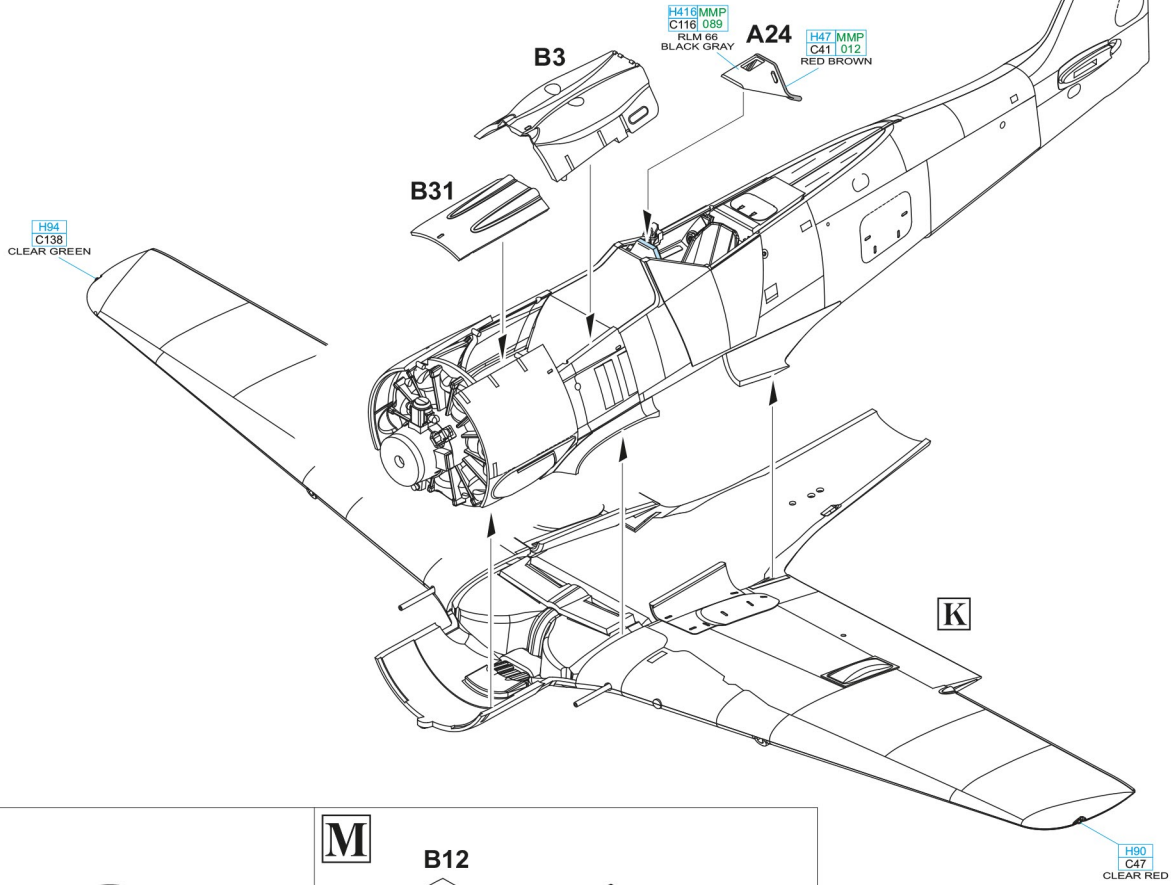
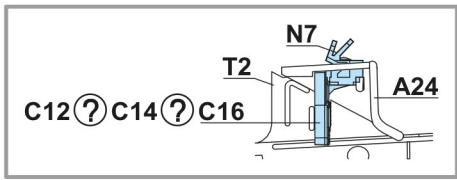

N

O

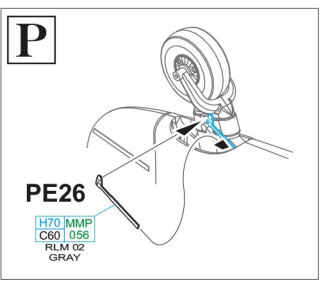
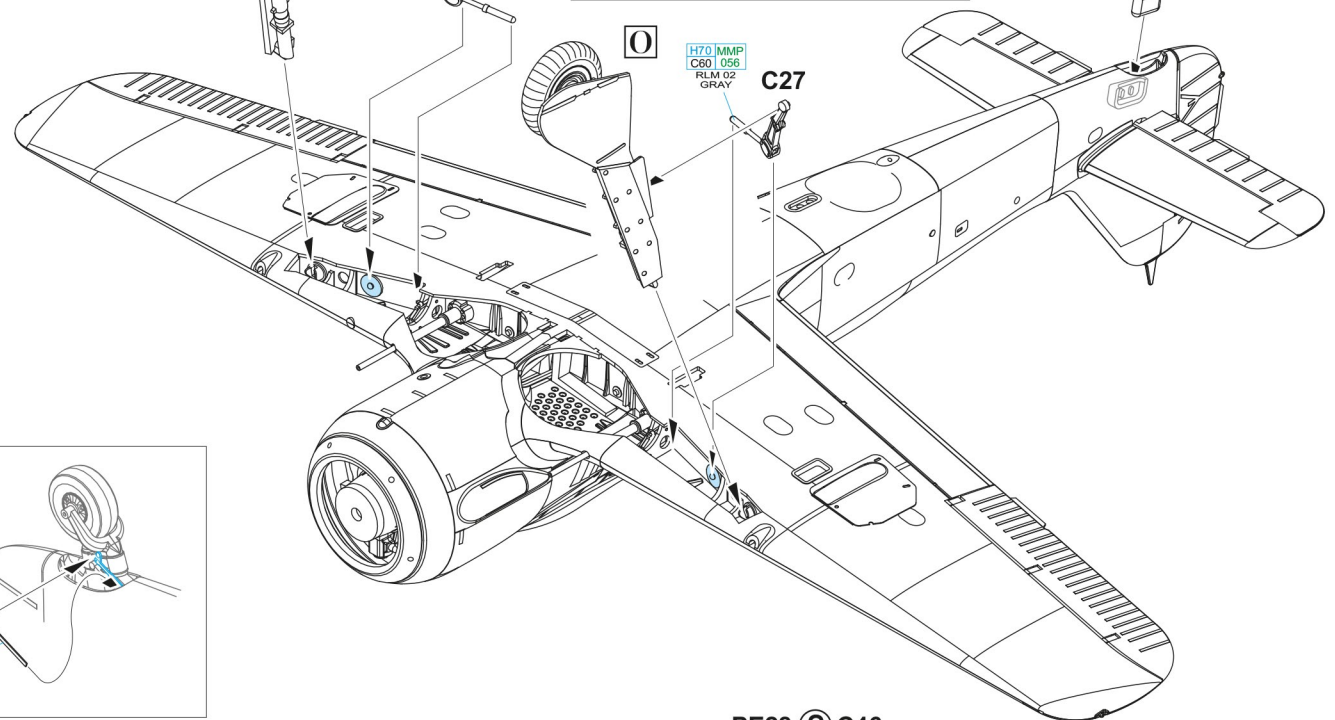
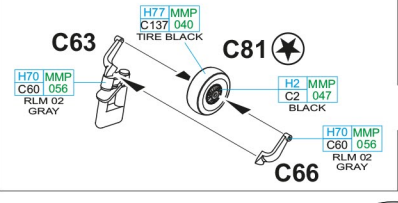
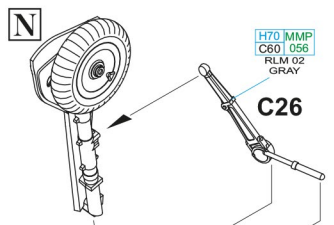
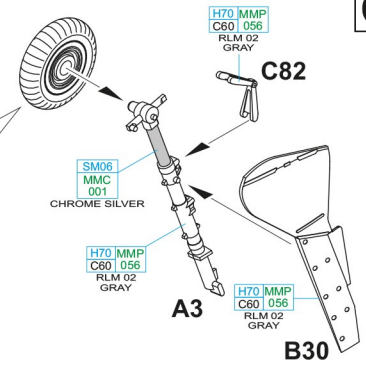
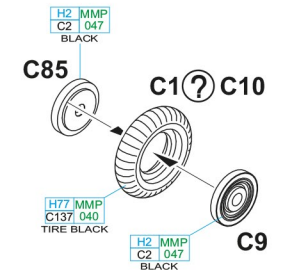
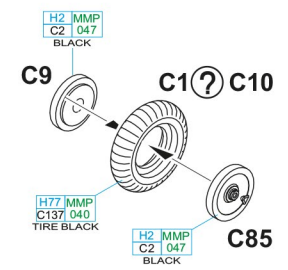
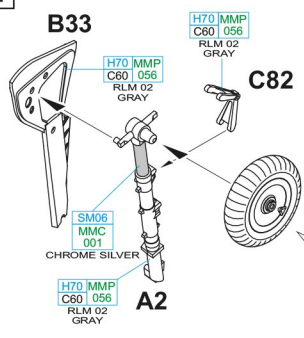

PE28 ? C46

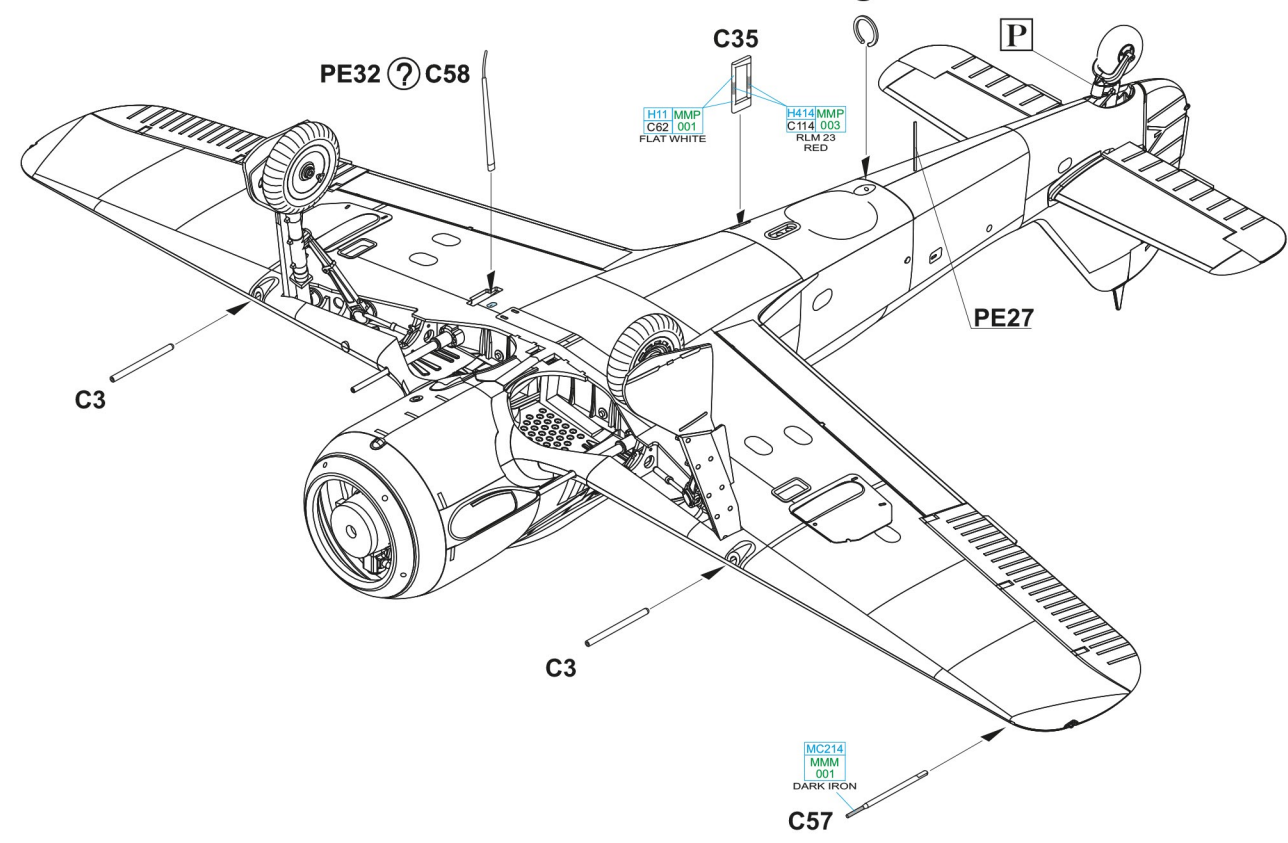

Q

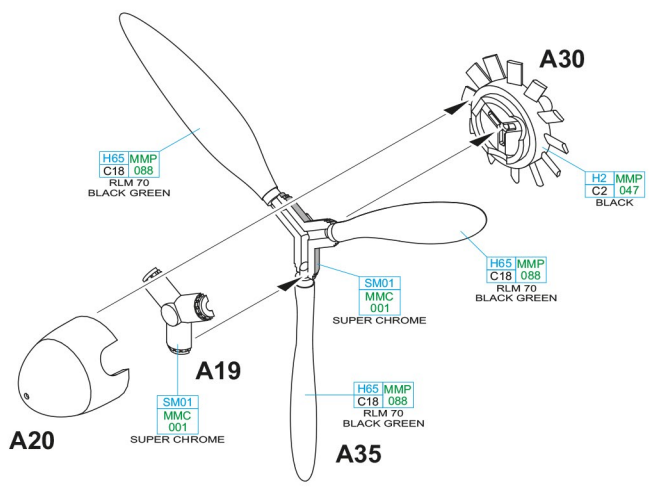

R

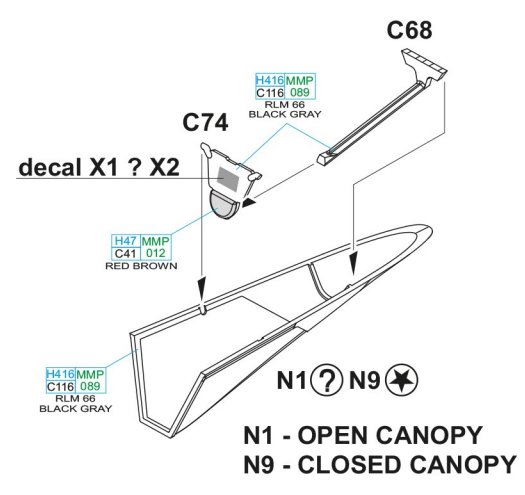

OPEN CANOPY

N4, N5 - MARKINGS A; B ONLY

N3 - MARKINGS B; C; D; E; F
N8 - MARKING A

H416 MMP C116 089 RLM 66 BLACK GRAY

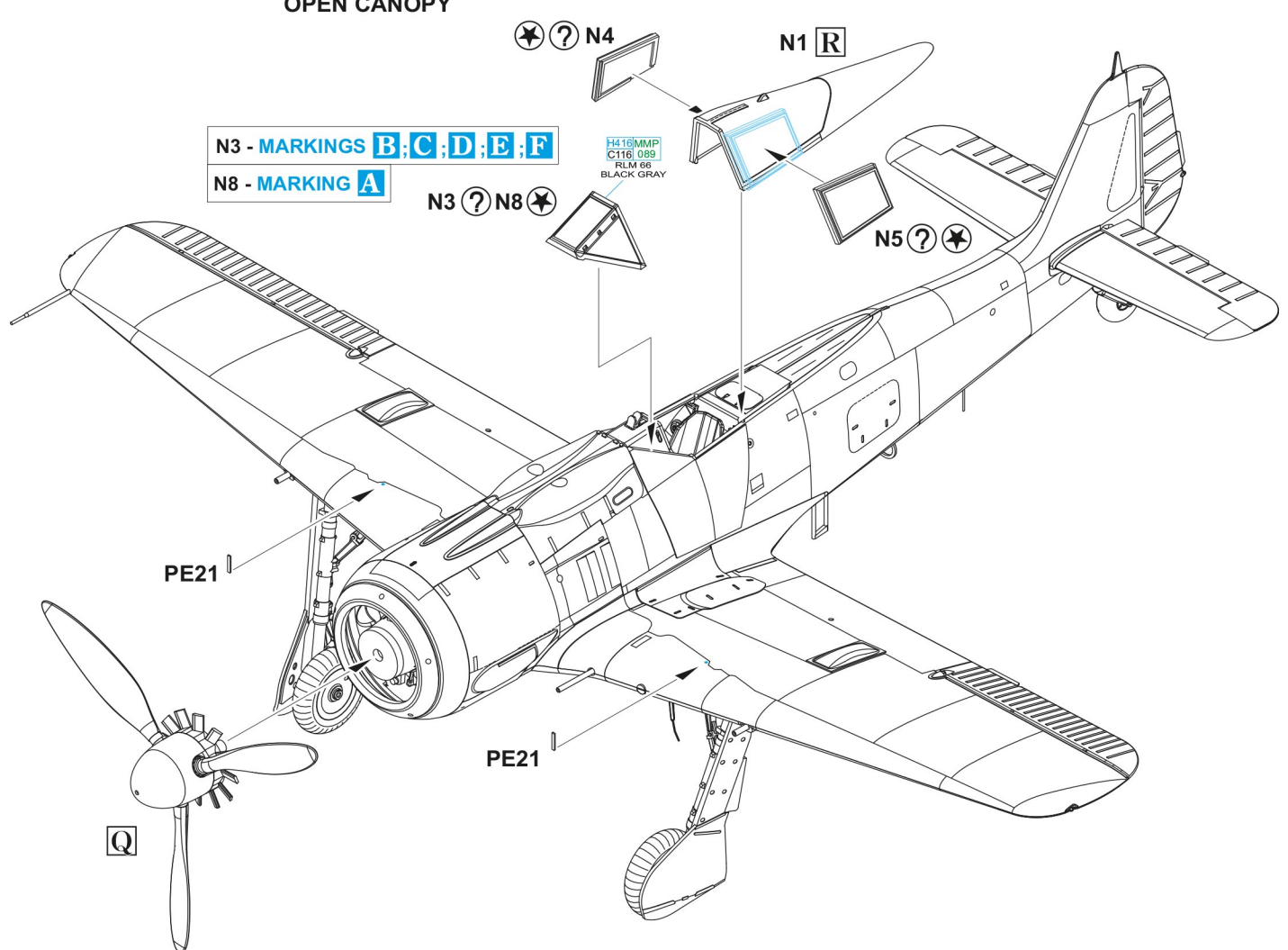

Q

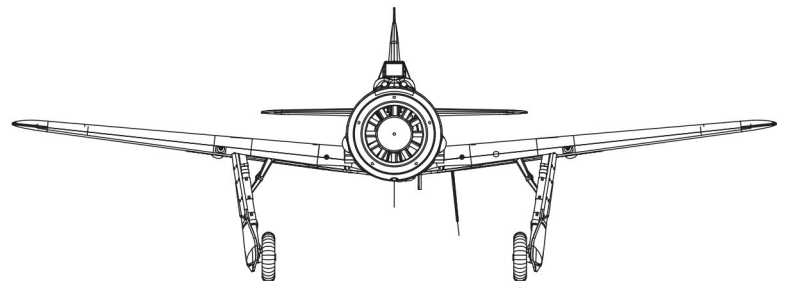
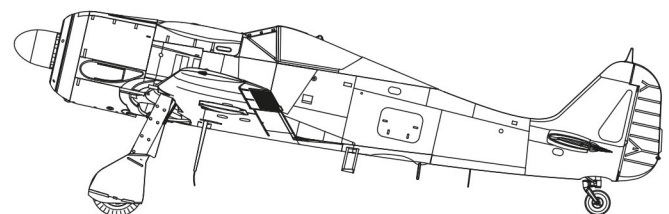

N4, N5 - MARKINGS A; B ONLY

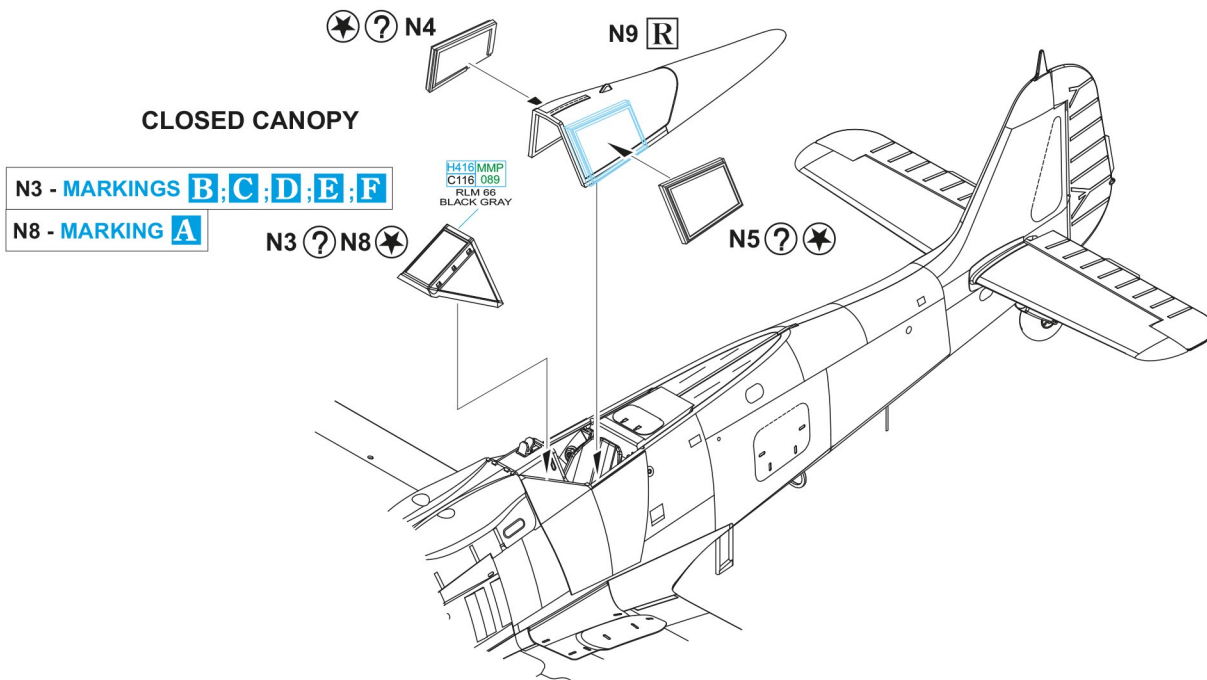

eduard
MASK
11119-A

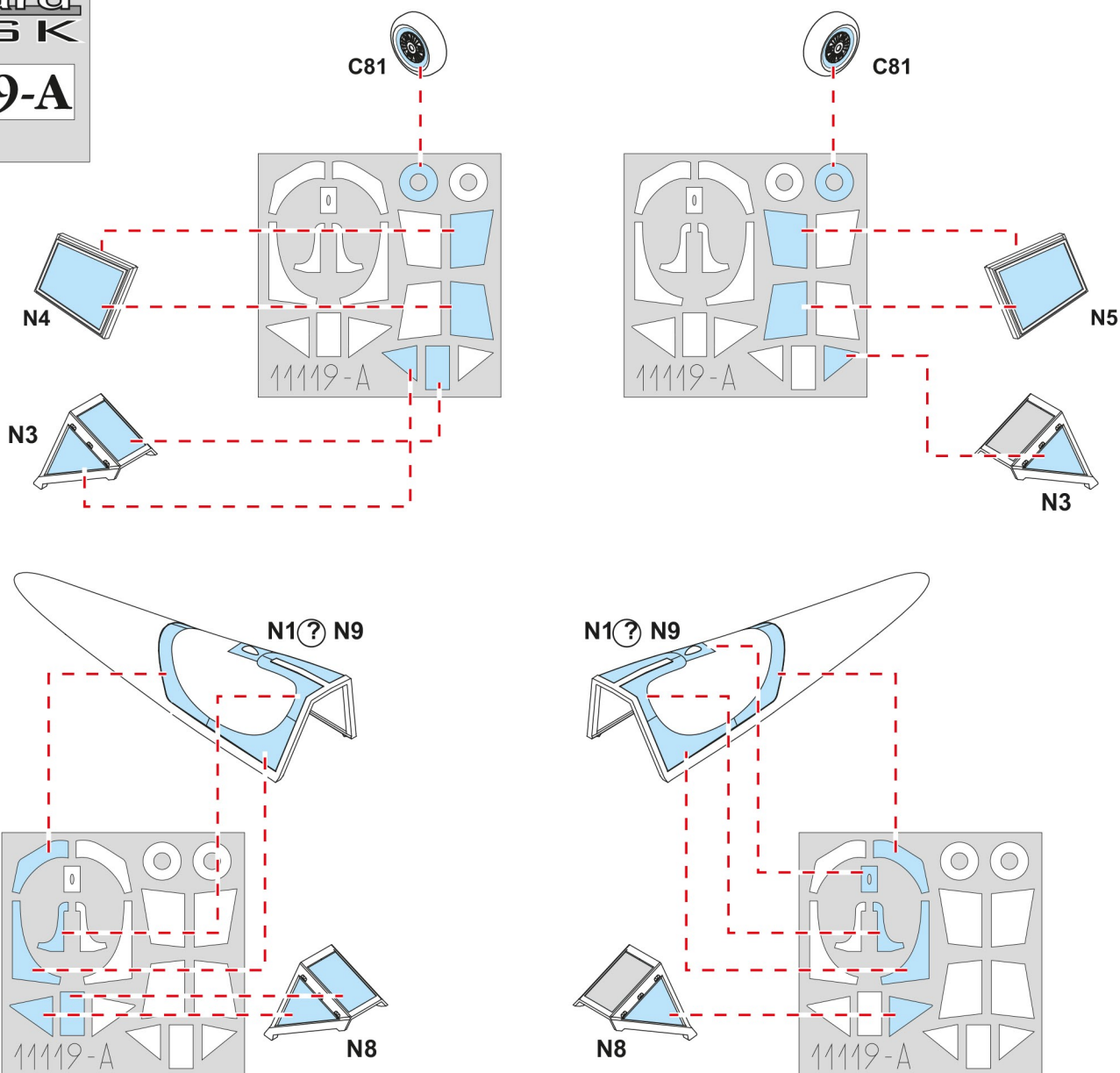

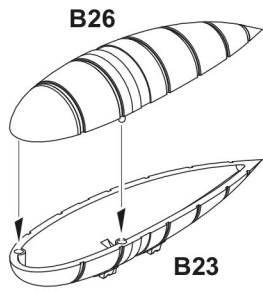

?

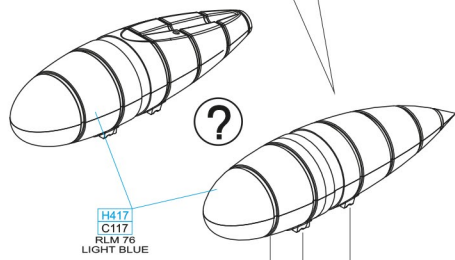
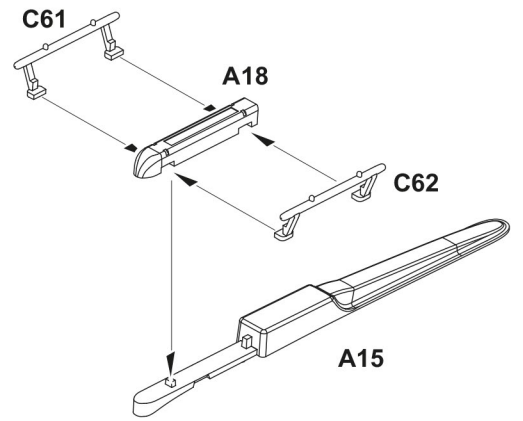
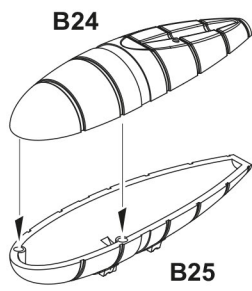

H417
C117
RLM 76
LIGHT BLUE

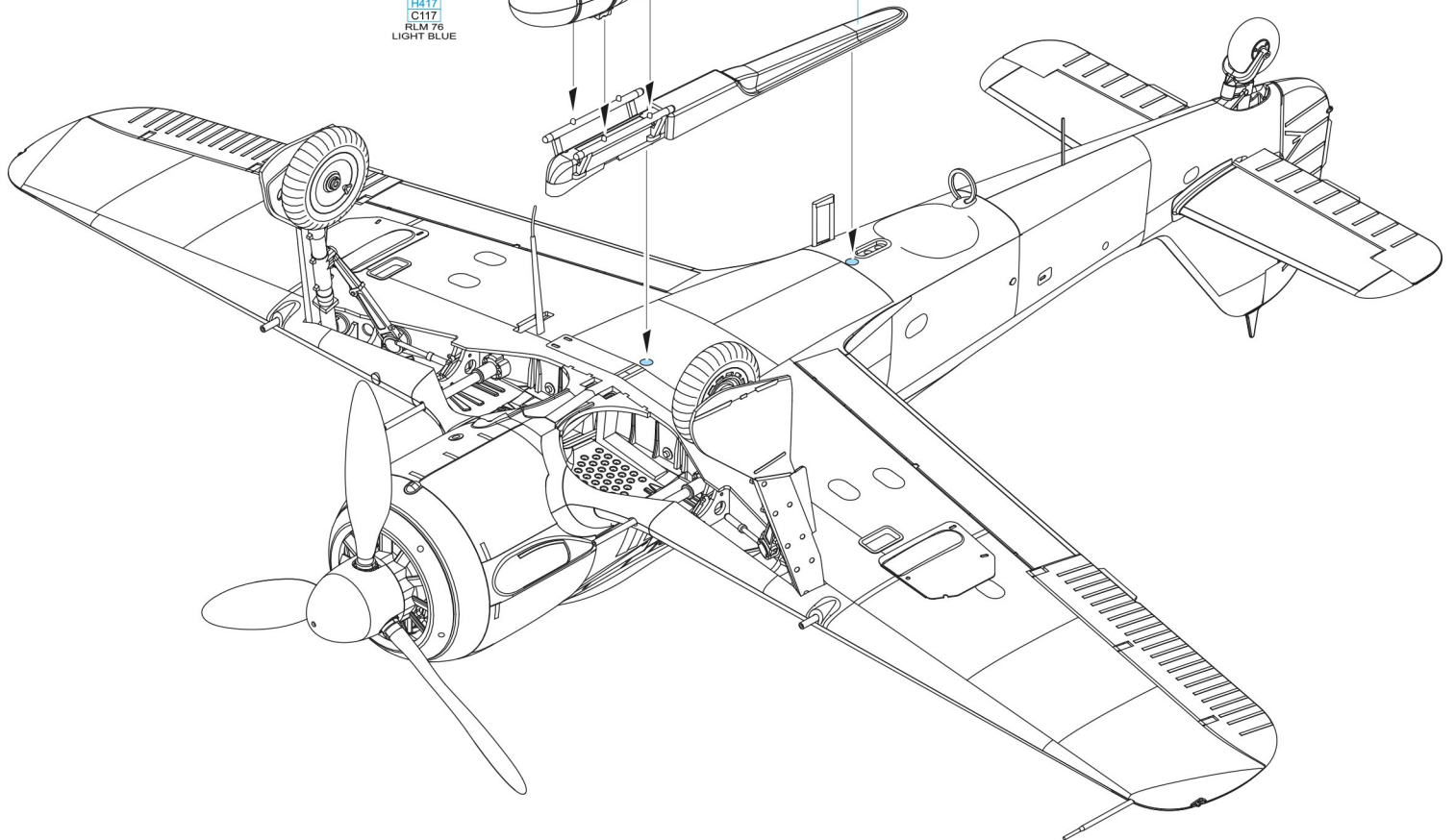

Bf 109G-6/14

ATTENTION *

UPOZORNĚNÍ *

ACHTUNG *

ATTENTION *

注意



Carefully read instruction sheet before assembling. When you use glue or paint, do not use near open flame and use in well ventilated room. Keep out of reach of small children. Children must not be allowed to suck any part, or pull vinyl bag over the head.



Před započatím stavby si pečlivě prostudujte stavební návod. Při používání barev a lepidel pracujte v dobře větrané místnosti. Lepidla ani barvy nepoužívejte v blízkosti otevřeného ohně. Model není určen malým dětem, mohlo by dojít k požití drobných dílů.

INSTRUCTION SIGNS * INSTR. SYMBOLY * INSTRUKTION SINNBILDEN * SYMBOLES * 記号の説明



OPTIONAL
VOLBA



BEND
OHNOU



OPEN HOLE
VYVRTAT OTVOR



SYMETRICAL ASSEMBLY
SYMETRICKÁ MONTÁŽ



REMOVE
ODRÍZNOUT



REVERSE SIDE
OTOČIT



APPLY EDUARD MASK
AND PAINT
POUŽIT EDUARD MASK
NABARVIT

PARTS *

DÍLY *

TEILE *

PIÈCES *

部品

PLASTIC PARTS

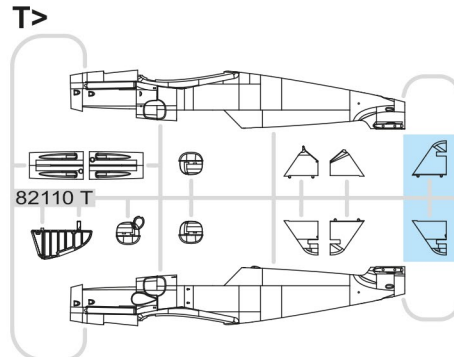
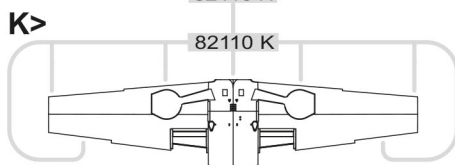
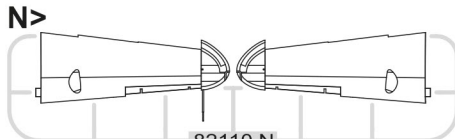
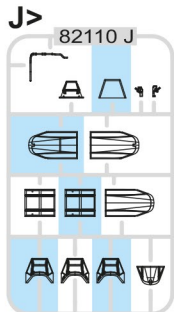
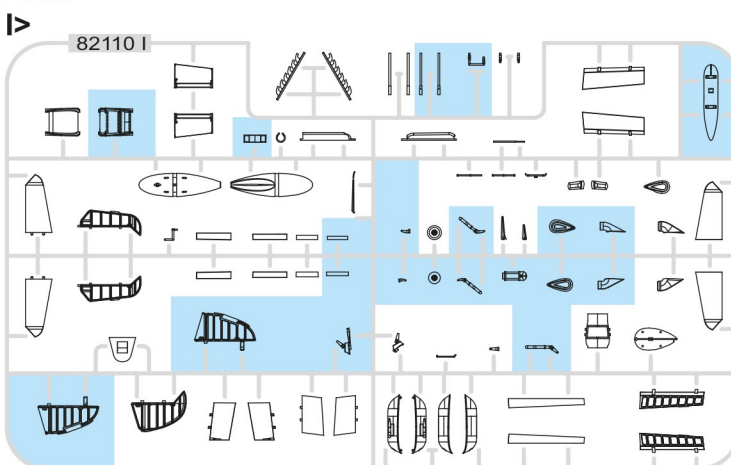
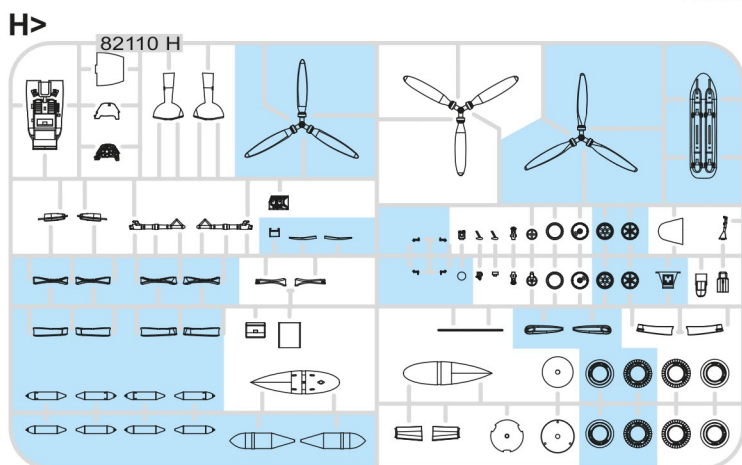

eduard
MASK

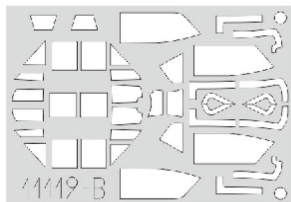

PE - PHOTO ETCHED DETAIL PARTS

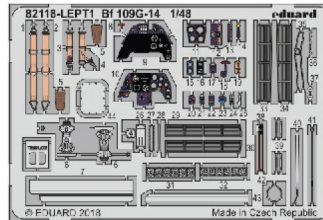

-Parts not for use. -Teile werden nicht verwendet. -Pièces à ne pas utiliser. -Tyto díly nepoužívejte při stavbě. - 使用しない部品

COLOURS *

BARVY *

FARBEN *

PEINTURE *

色

GSI Creos (GUNZE)		MISSION MODELS	
AQUEOUS	Mr.COLOR	PAINTS	
H2	C2	MMP-047	BLACK
H5	C5	MMP-048	BLUE
H11	C62	MMP-001	FLAT WHITE
H12	C33	MMP-047	FLAT BLACK
H15	C65		BRIGHT BLUE
H47	C41	MMP-012	RED BROWN
H65	C18	MMP-088	RLM70 BLACK GREEN
H68	C36	MMP-049	RLM74 DARK GRAY
H69	C37	MMP-050	RLM75 GRAY
H70	C60	MMP-056	RLM02 GRAY
H77	C137	MMP-040	TIRE BLACK
H90	C47		CLEAR RED

GSI Creos (GUNZE)		MISSION MODELS	
AQUEOUS	Mr.COLOR	PAINTS	
H94	C138		CLEAR GREEN
H319	C319		LIGHT GREEN
H413	C113	MMP-090	RLM04 YELLOW
H414	C114		RLM23 RED
H416	C116	MMP-089	RLM66 BLACK GRAY
H417	C117	MMP-051	RLM76 LIGHT BLUE
Mr.METAL COLOR		METALLICS	
MC213		MMM-006	STEEL
MC214		MMM-001	DARK IRON
Mr.COLOR SUPER METALLIC		METALLICS	
SM01		MMC-001	SUPER CHROME

MARKINGS **K**, **L**, **M** ONLY

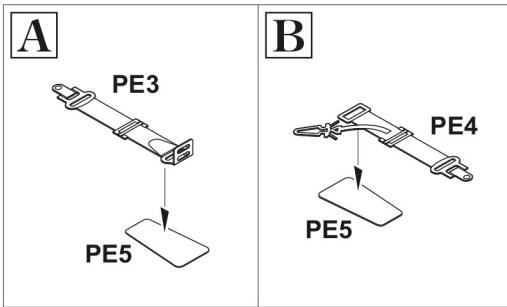
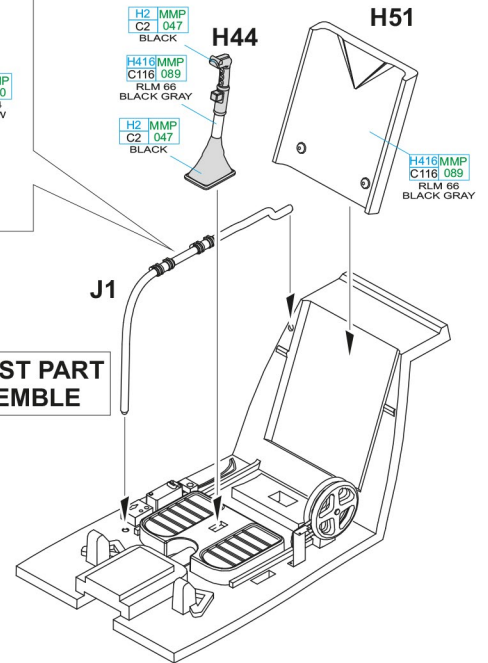
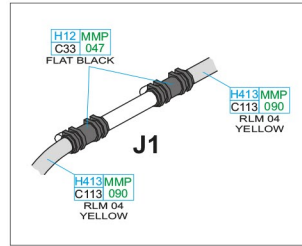
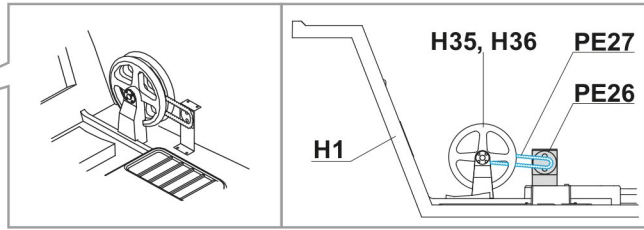
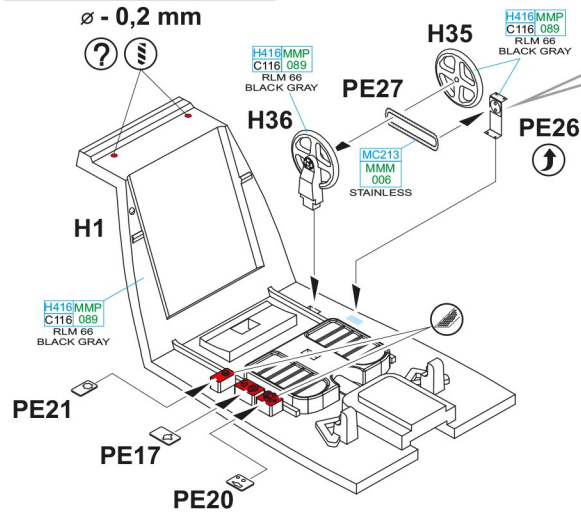

THE LATEST PART TO ASSEMBLE

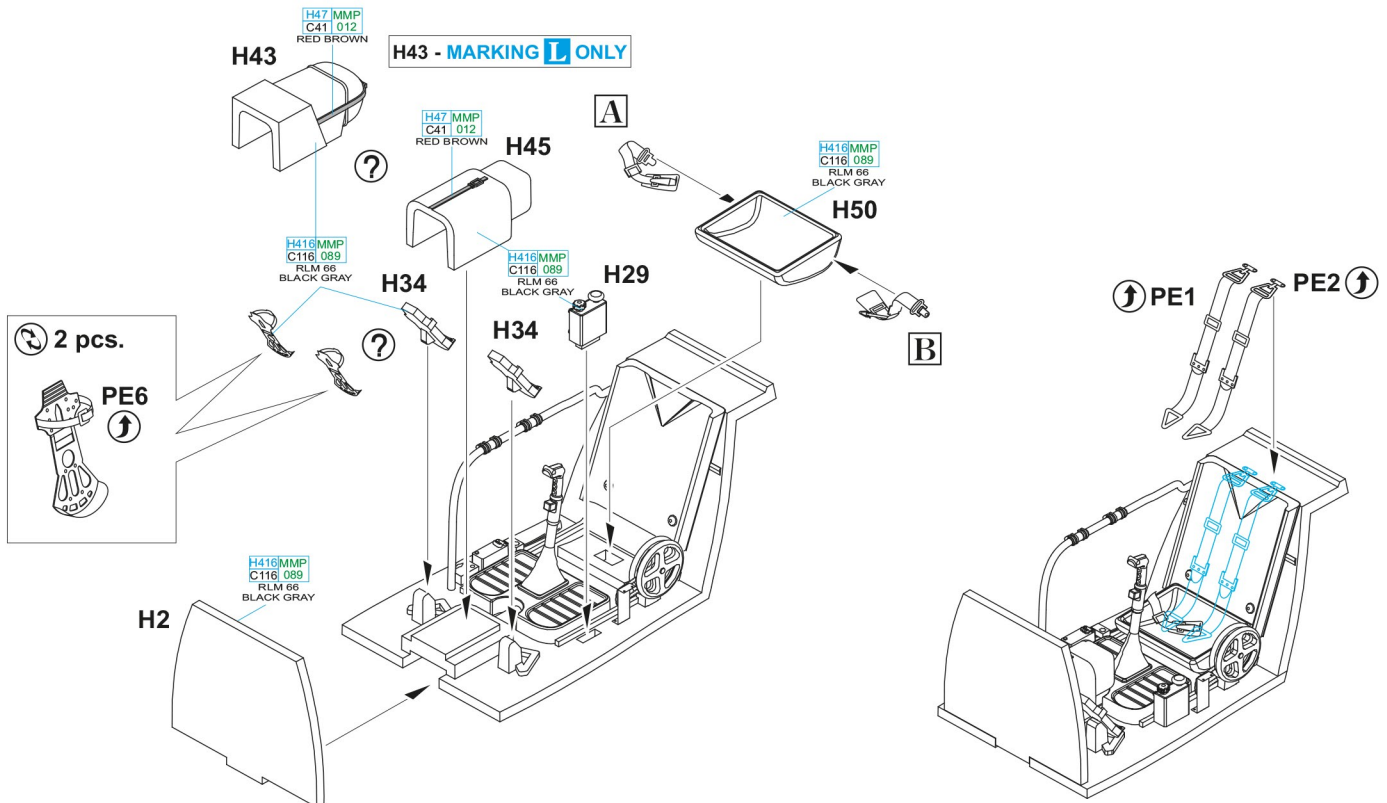

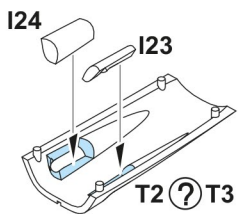

T2 ? T3

T2 - MARKINGS I, K, L, M

T3 - MARKINGS G, H, J

H41 - MARKINGS G, H, I, J, K

I57 - MARKINGS L, M

H41 ? I57

T5 - MARKINGS I, K, L, M

T6 - MARKINGS G, H, J

T5 ? T6

H41 MMP
C116 089
RLM 66
BLACK GRAY

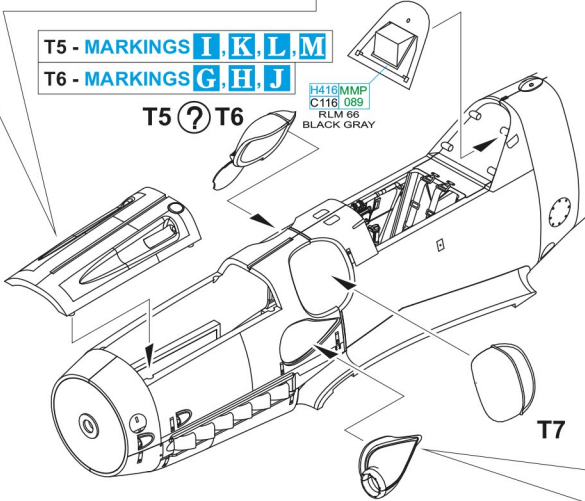

I55

I54

I26

T7

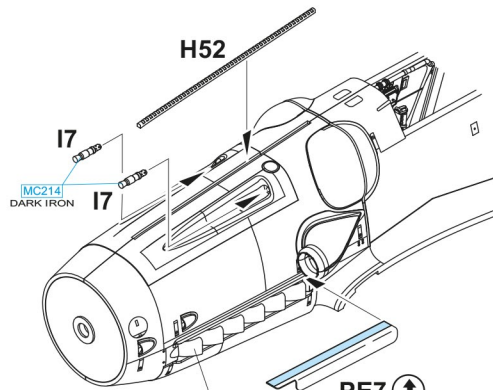

PE7 ↑
PE7 with I2 only

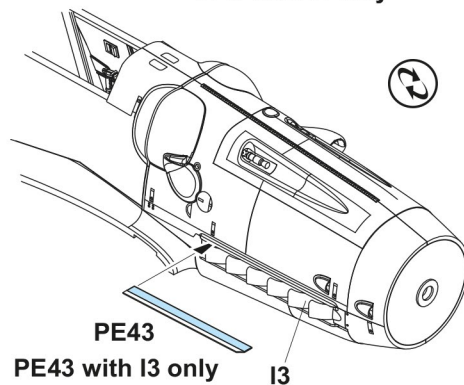

PE43
PE43 with I3 only

MARKINGS G, H, I, L

MARKINGS J, K, M

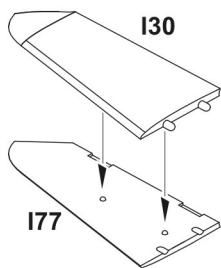

I30

I77

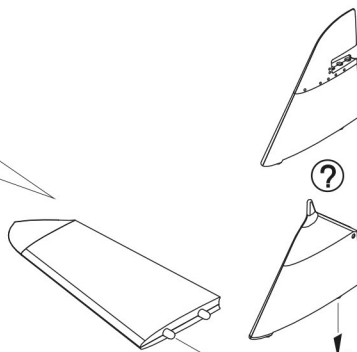

?

T10

?

T9

T11

T8

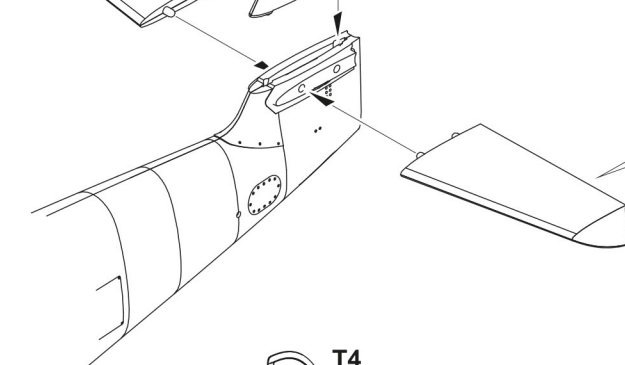

I29

I28

T4

I58 - MARKINGS G, H, I, L

T4 - MARKINGS J, K, M

I66

H70 MMP
C60 056
RLM 02
GRAY

H2 MMP
C2 047
BLACK

H70 MMP
C60 056
RLM 02
GRAY

I67 MMP
C137 040
TIRE BLACK

I43

I71

I32

I58

I31

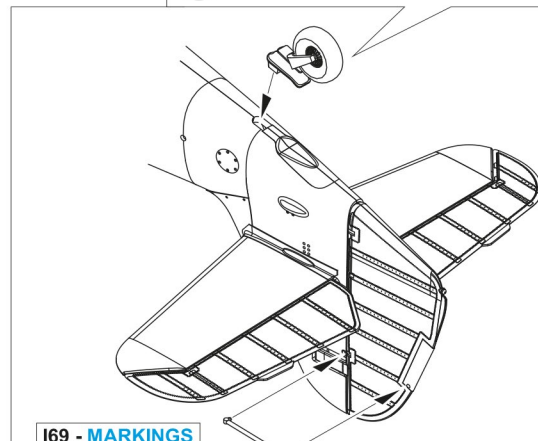
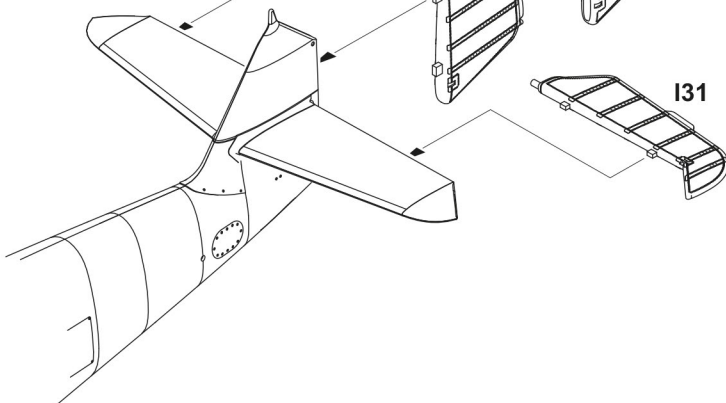

I69 - MARKINGS J, K, M ONLY

I69

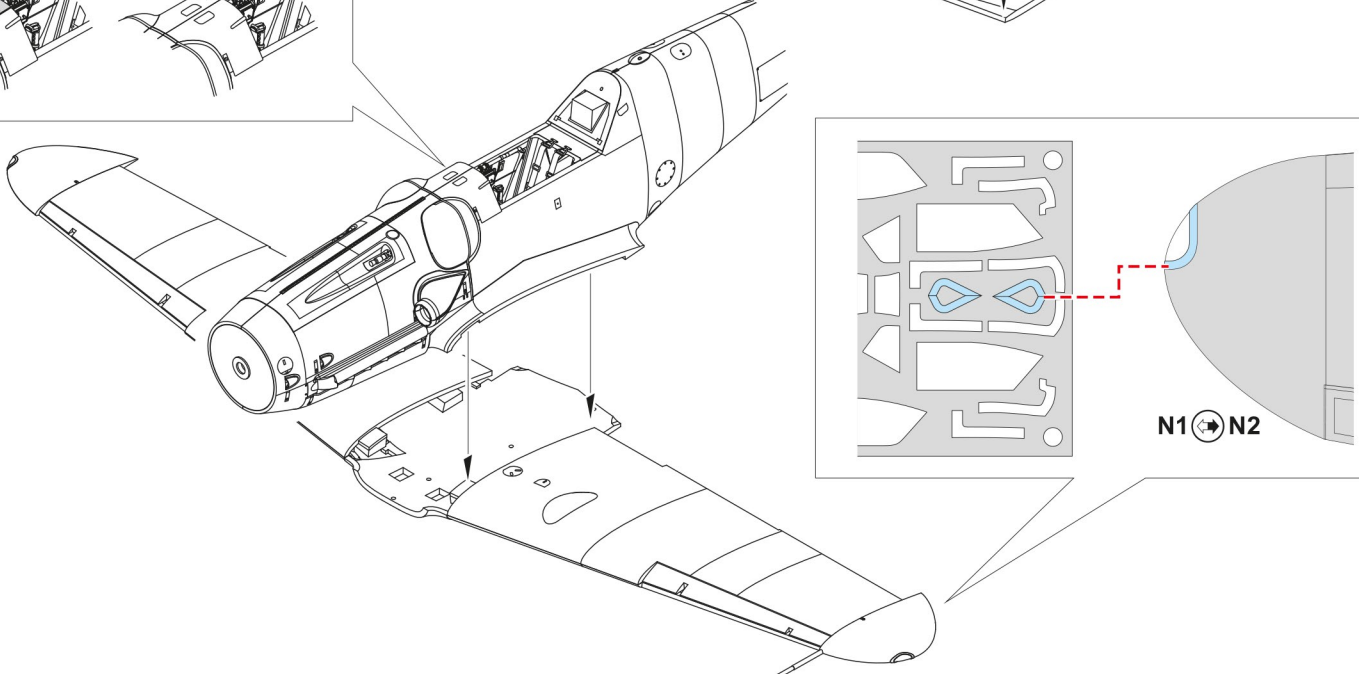
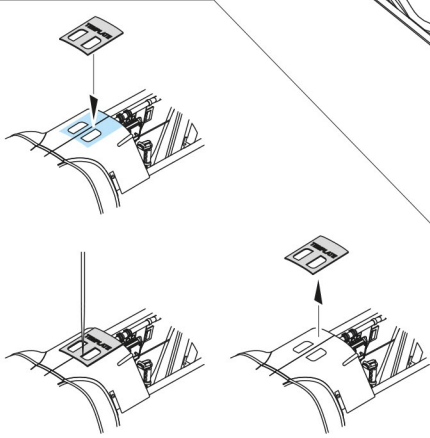
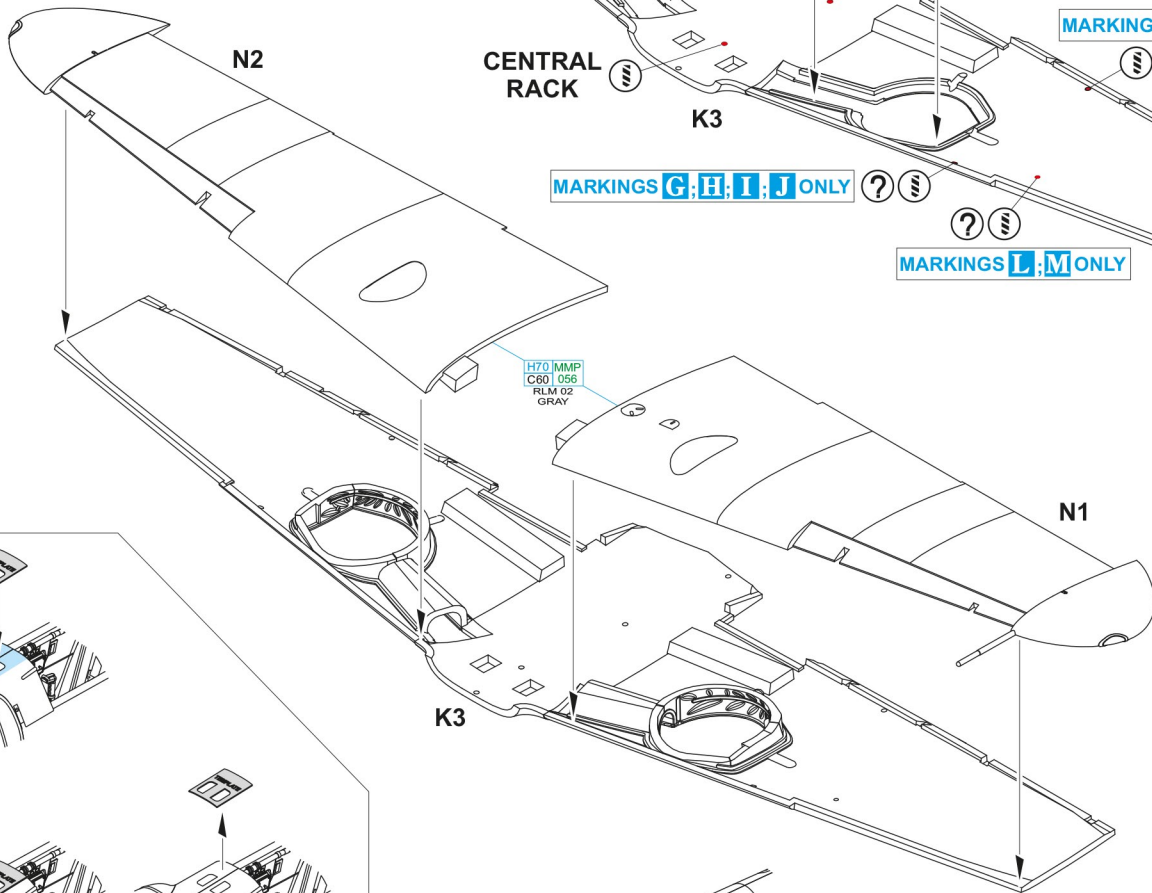
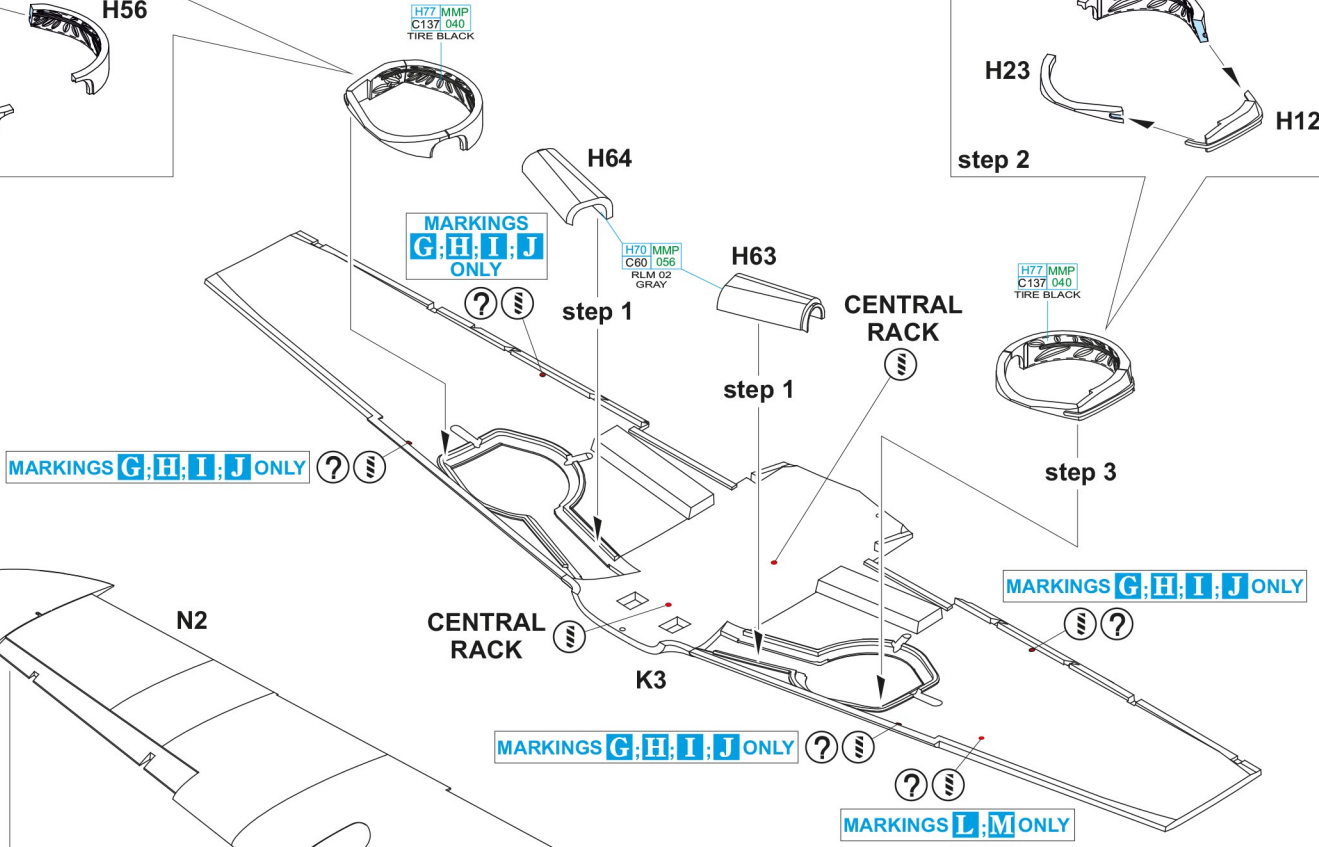
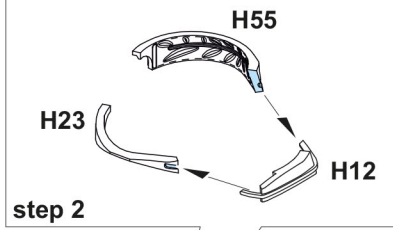
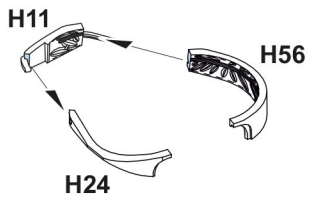

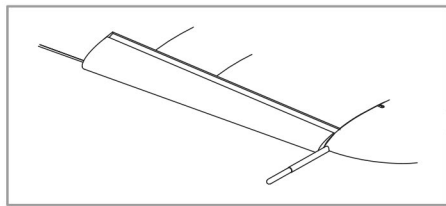
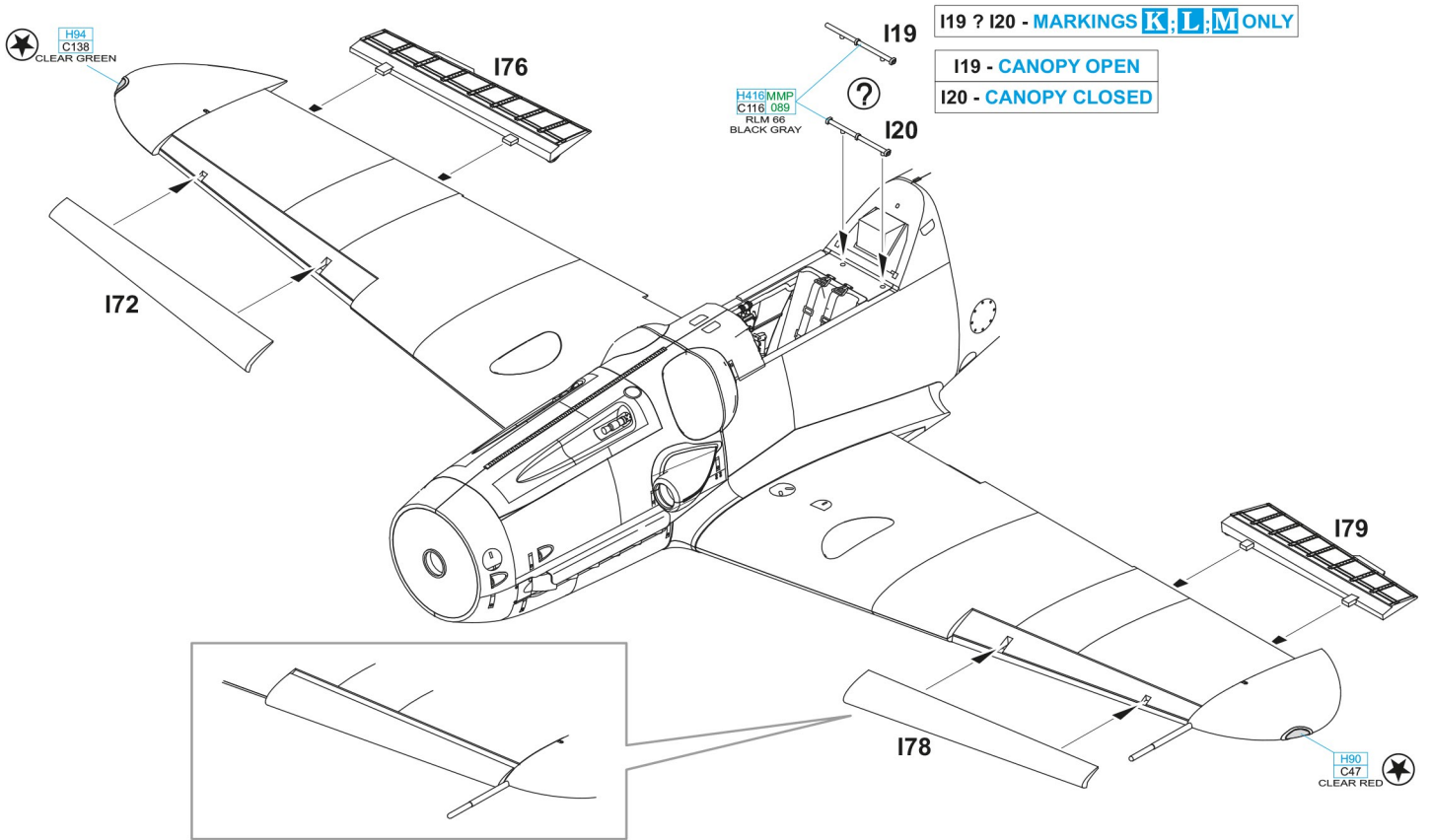

FRONT VIEW

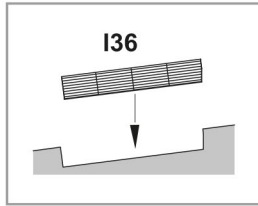

FRONT VIEW

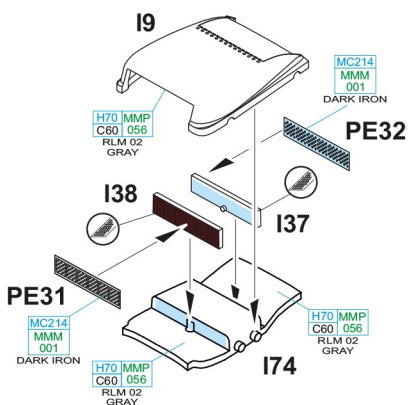
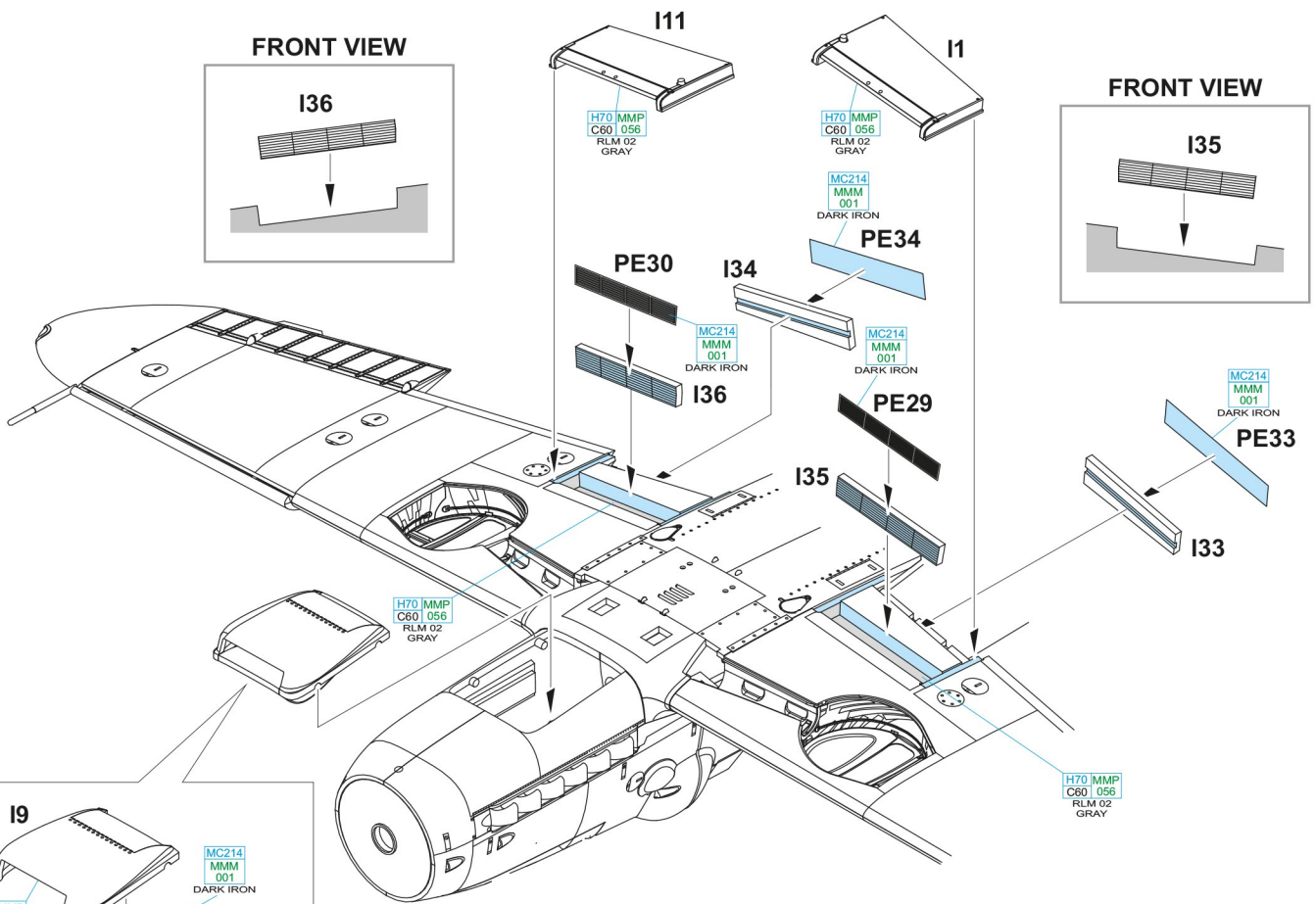
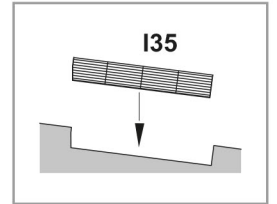

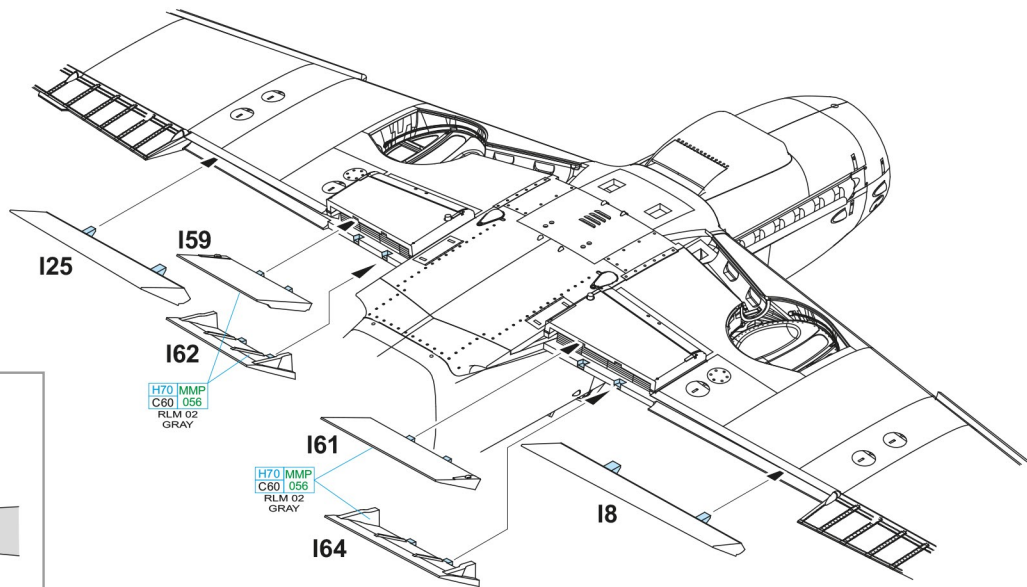

CORRECT POSITION OF RADIATOR FLAPS

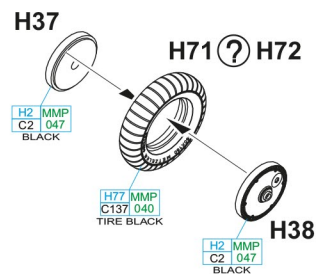
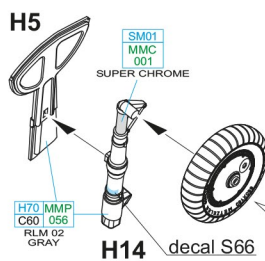
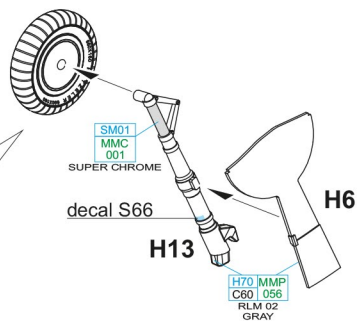
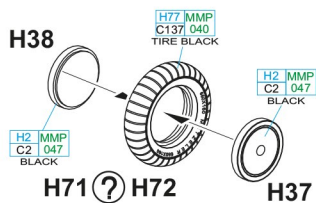
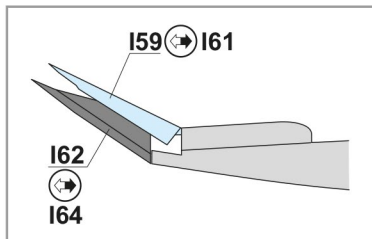

**I17 ? PE40 - MARKINGS
L; M ONLY**

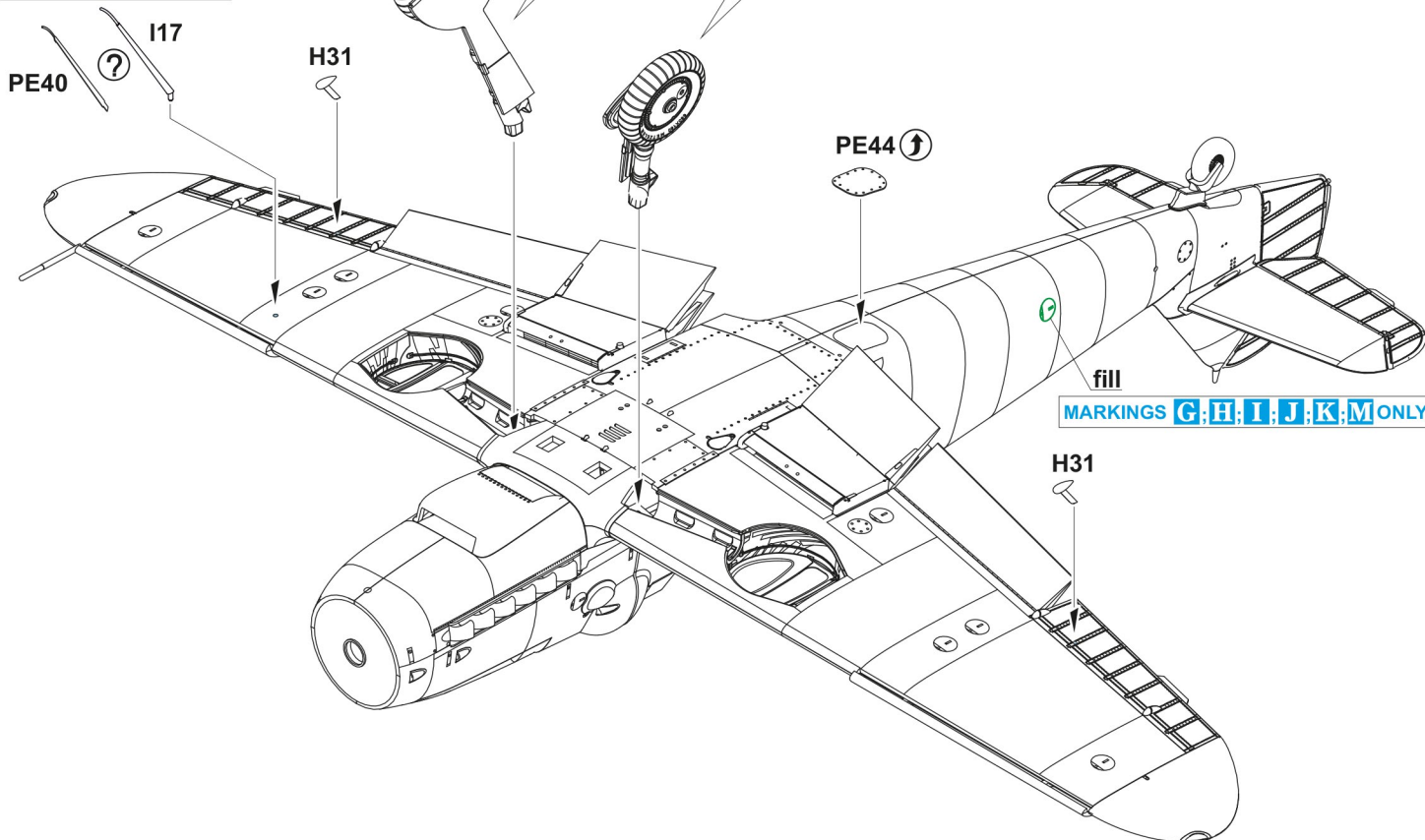

J4 ? J5

J5 - MARKINGS L; M ONLY

C

H12 MMP
C33 047
FLAT BLACK

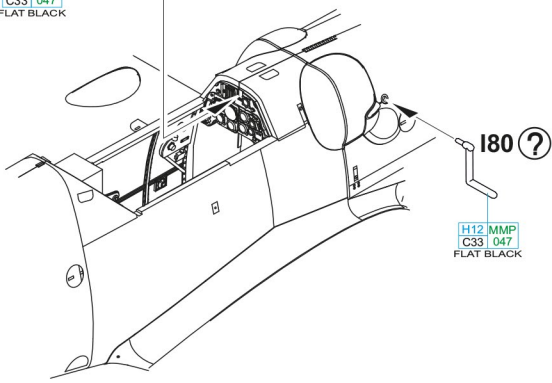

H12 MMP
C33 047
FLAT BLACK

D

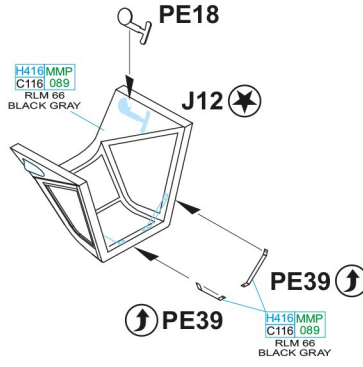

H416 MMP
C116 089
RLM 66
BLACK GRAY

H416 MMP
C116 089
RLM 66
BLACK GRAY

E

J10 - MARKING K ONLY

J9 ? J10

- 0,2 mm
l - 0,5 mm
plastic

H416 MMP
C116 089
RLM 66
BLACK GRAY

H416 MMP
C116 089
RLM 66
BLACK GRAY

PE25



J9 ? J10

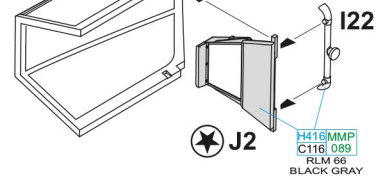

H416 MMP
C116 089
RLM 66
BLACK GRAY

F

PE36

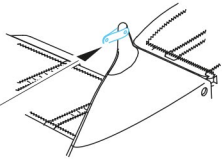

I49 - MARKINGS K, M

I49 ?

I49 - MARKING L

I49 ?

MARKINGS K; L; M ONLY

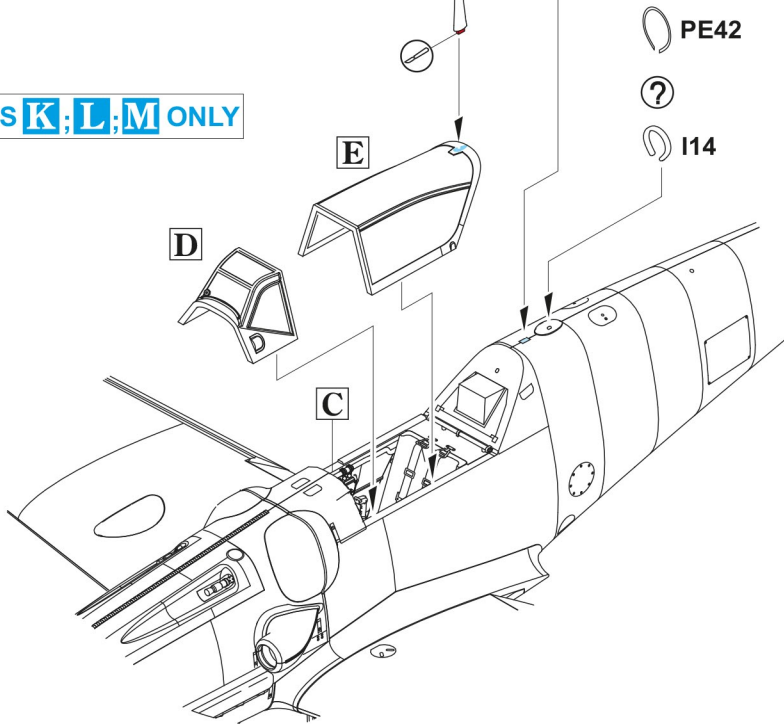

PE42

?

I14

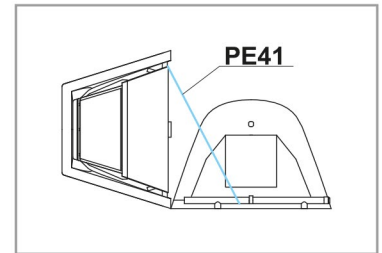

PE41

OPEN CANOPY

G

H68

H8

H66

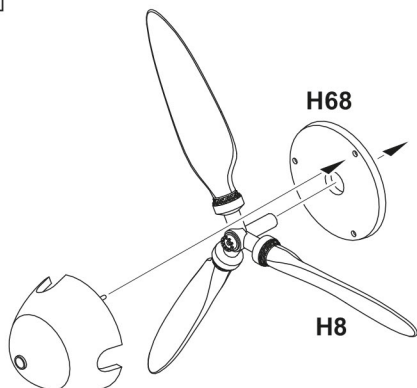

H416 MMP
C116 089
RLM 66
BLACK GRAY

PE41

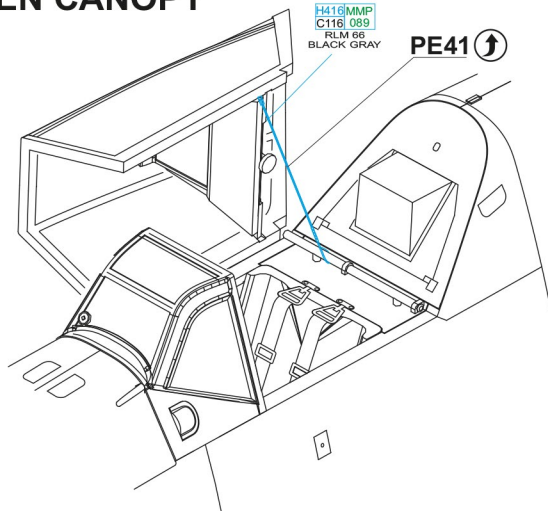

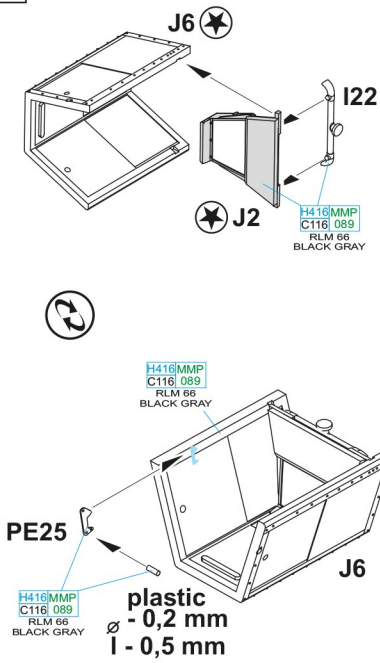
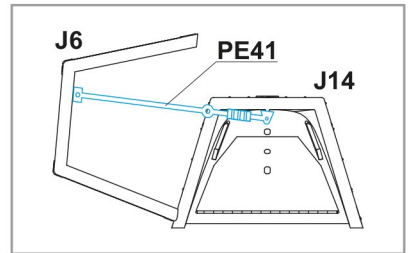
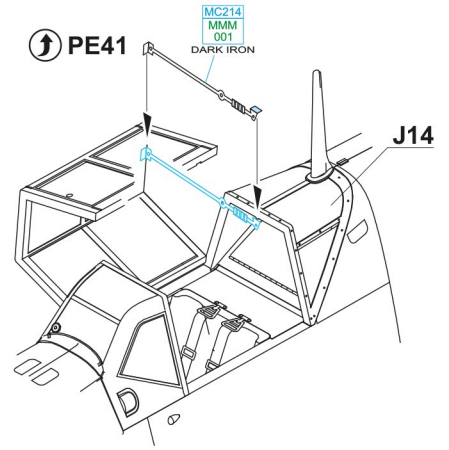
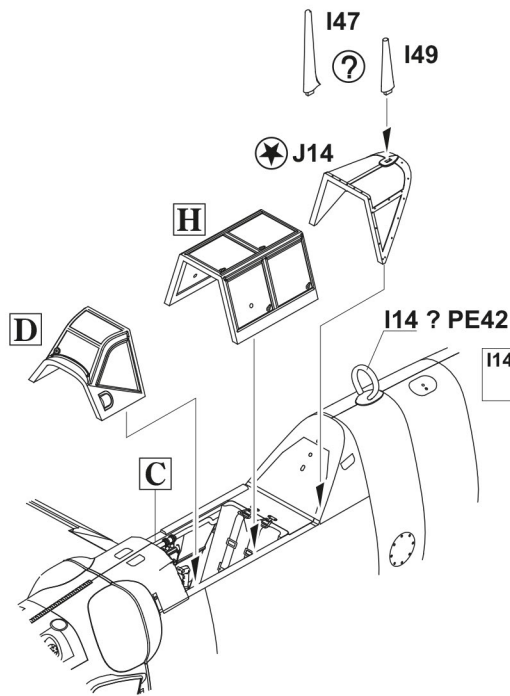
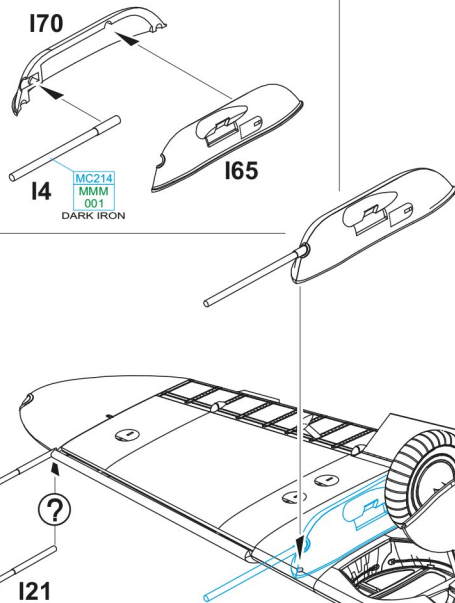
H**MARKINGS G; H; I; J ONLY****OPEN CANOPY**I47 - MARKING **H**I49 - MARKINGS **G; I; J****MARKINGS G; H; I; J ONLY**H417MMP
C117 051
RLM 76
LIGHT BLUE

?

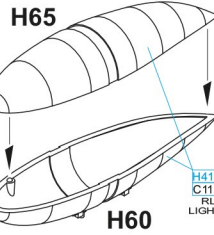
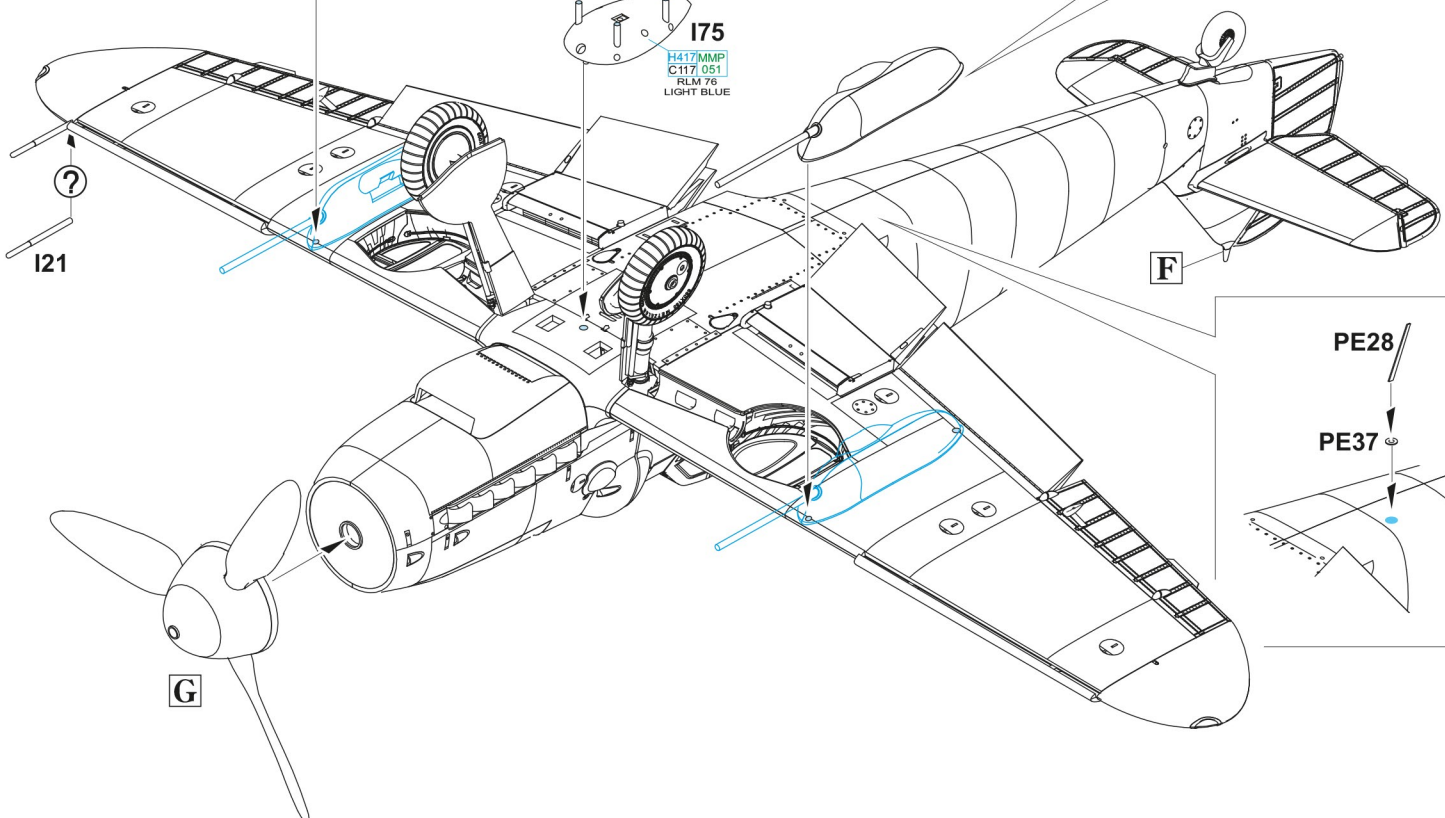
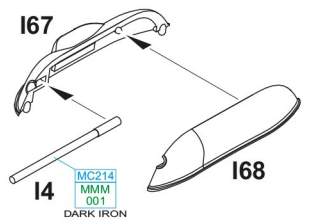
**MARKINGS G; H; I; J ONLY**

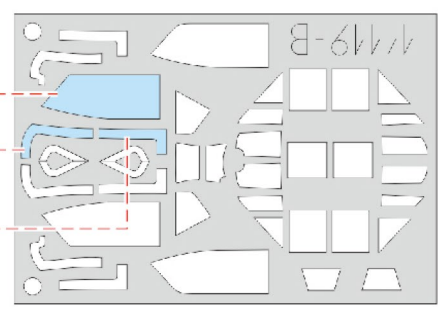
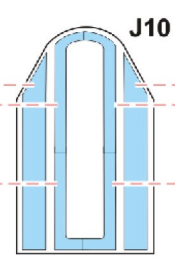
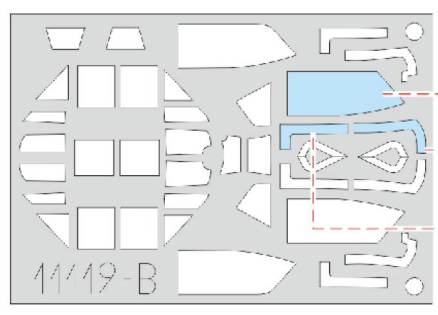
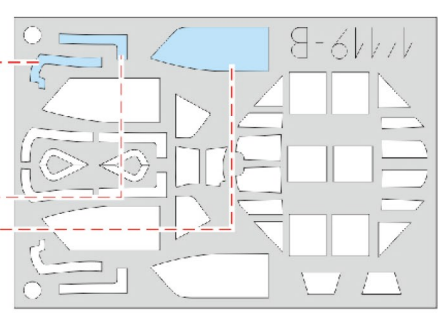
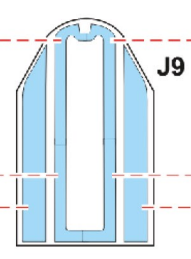
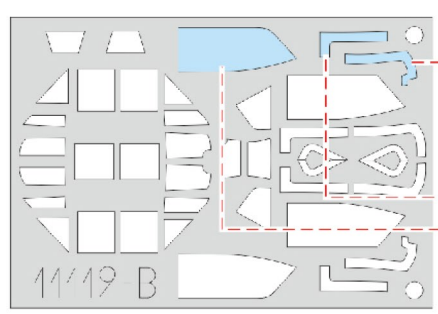
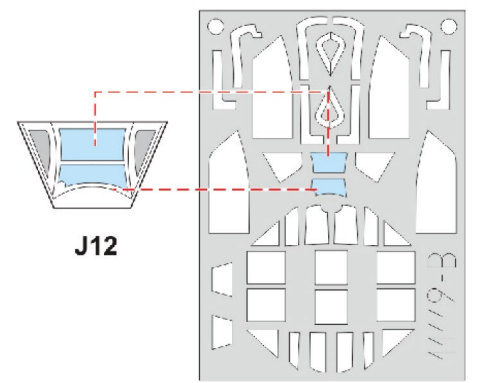
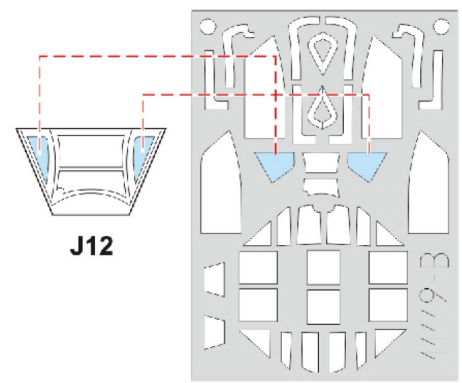
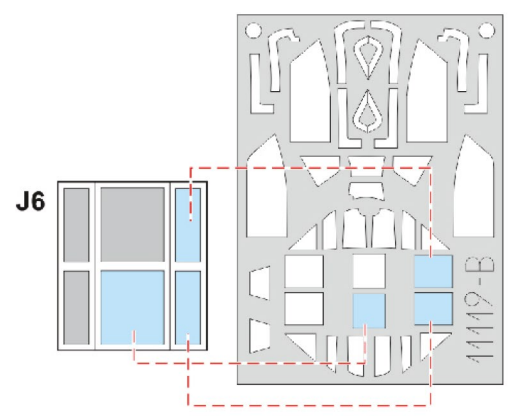
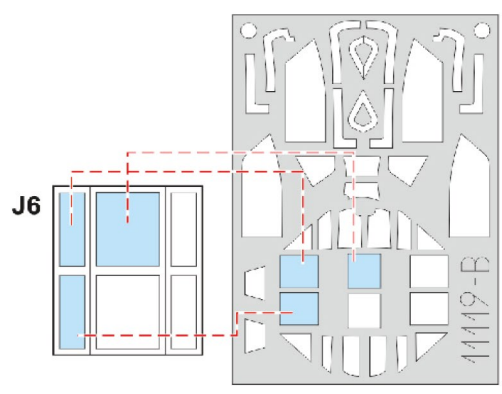
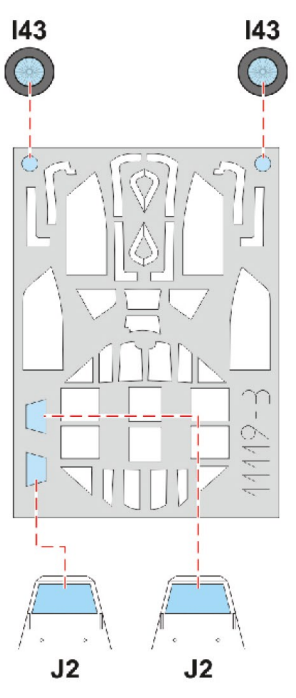
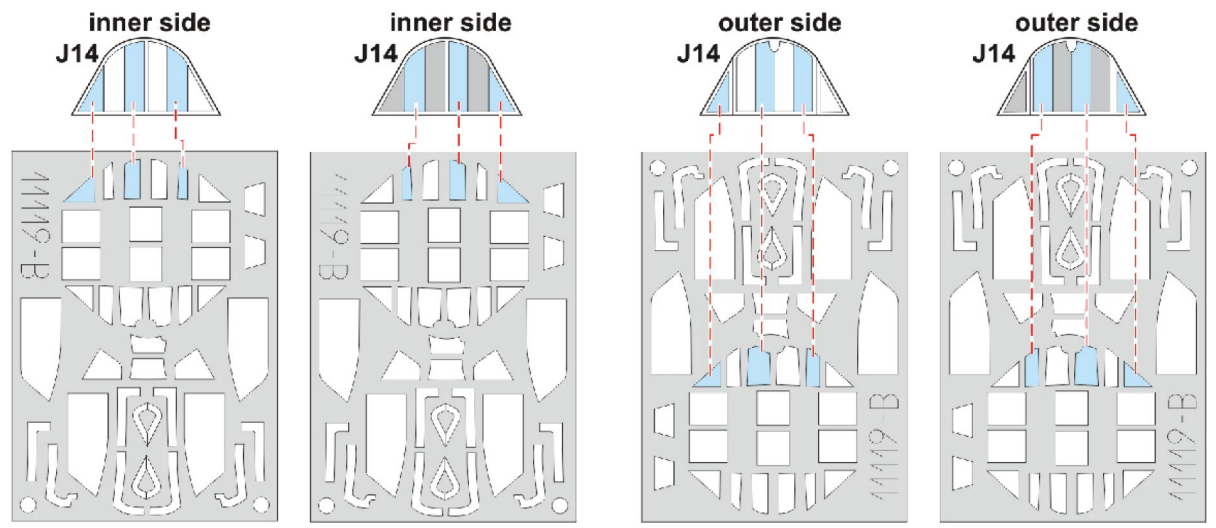

B Fw 190A-8/R2, W. Nr. 681420, flown by Lt. Alfred Lausch, 8.(Sturm)/ JG 4, Welzow, Germany, September 1944

Alfred Lausch came from a Czech family in the Javorice Highlands, located in the eastern Sudetenland. After the outbreak of the war, he was enlisted into the Luftwaffe as a German national where he flew Fw 189 reconnaissance aircraft over the Eastern Front. Here he flew more than 300 missions. On July 26th, 1943, he was awarded the Deutsches Kreuz in Gold. After undergoing fighter training, he was assigned to the 8.(Sturm)/ JG 4 in the summer of 1944 and flew its inaugural missions on September 11th, 1944. On that day, his unit entered combat with bombers of the 13th Combat Wing, 8th USAAF that were headed for the refineries in Ruhland. During the intercept, which today we call the Battle Over the Ore Mountains, Lt. Lausch managed to bring down a B-17G of the 95th Bomb Group north of Chomutov. He himself was hit by an escorting P-51 and his aircraft hit the ground near Reitzenhain on the Czech side of the Ore Mountains. The pilot did not survive. The remains of the aircraft are now in the possession of the Museum of the Battle Over the Ore Mountains. Lausch's standard camouflaged Sturmbock carried the 900 mm Defence of the Reich JG 4 black-white-black fuselage band and on the nose the JG 4 unit marking. To aid in pilot protection, 5 mm thick armoured panels were added below the cockpit and the windscreen was complemented by 30 mm thick glass plating. This aircraft had the armoured glass on the sides of the sliding portion of the canopy.

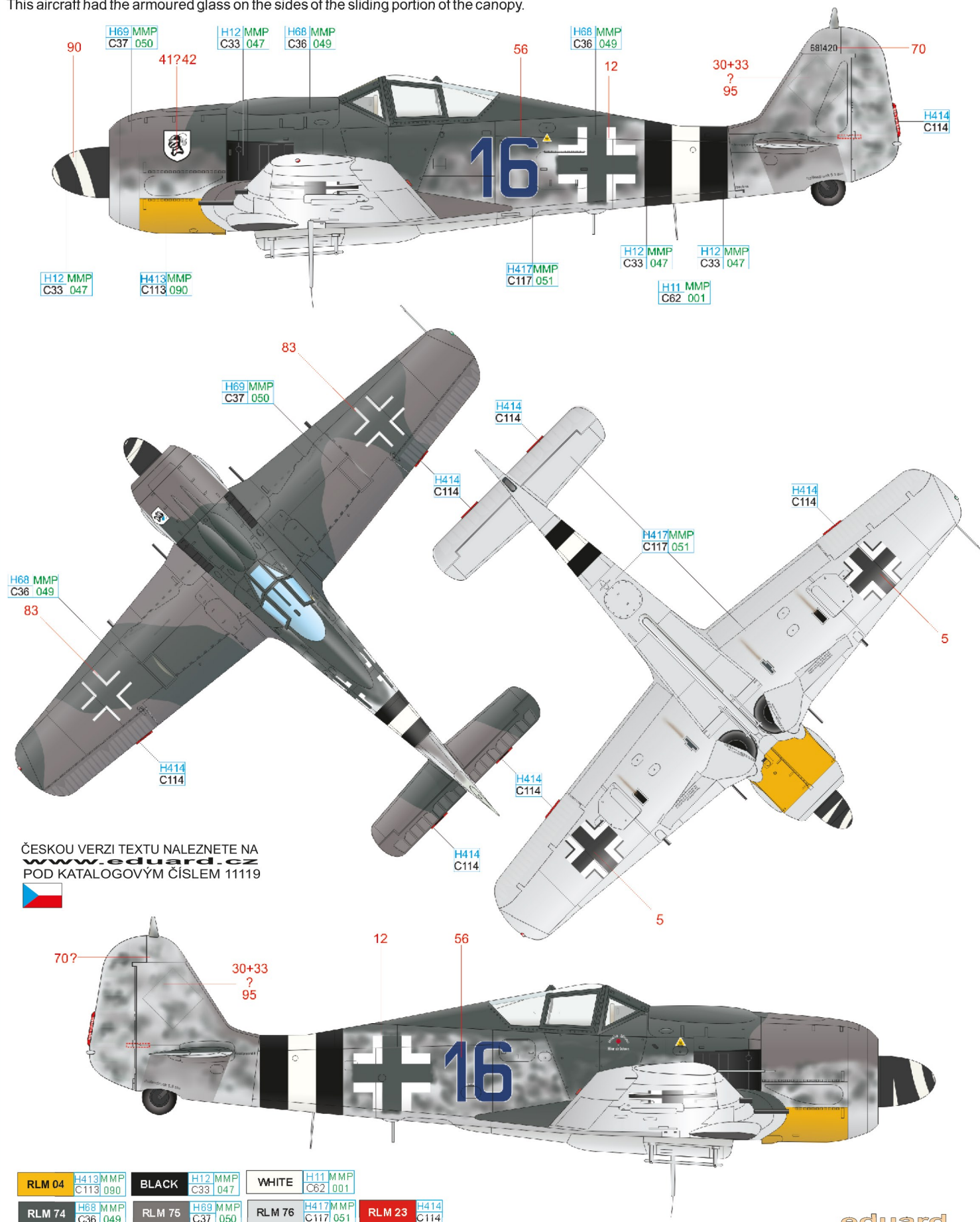

ČESKOU VERZI TEXTU NALEZNETE NA www.eduard.cz POD KATALOGOVÝM ČÍSLEM 11119



RLM 04	H413 MMP C113 090	BLACK	H12 MMP C33 047	WHITE	H11 MMP C62 001
RLM 74	H68 MMP C36 049	RLM 75	H69 MMP C37 050	RLM 76	H417 MMP C117 051
				RLM 23	H414 C114

C Fw 190A-8/R2, W. Nr. 682958, flown by Uffz. Paul Lixfeld, 6.(Sturm)/ JG 300, Löbnitz, Germany, December 1944

As was the case with sister unit JG 301, JG 300 was originally tasked with night interception of Allied bomber raids into occupied Europe. At the beginning of 1944, the unit's role was changed to day fighting. II. Gruppe was formed in July 1943 and received heavily armed and armoured Fw 190A-8/R2 aircraft in the summer of 1944 designed to combat the Allied raids and continued to be designated as a Sturmgruppe. One of the pilots of this unit became eighteen-year-old Uffz. Paul Lixfeld who's 'Yellow 12' carried the name 'Muschi'. JG 300 aircraft flying within the Defence of the Reich system carried a red fuselage band. Lixfeld's Sturmbock didn't carry the side armoured glass panels on the sliding section of the canopy, nicknamed 'Scheuklappe' (horse blinds). Many Sturmbocks had these removed because of freezing condensation between the armoured panels and the canopy proper, limiting visibility from the airplane.

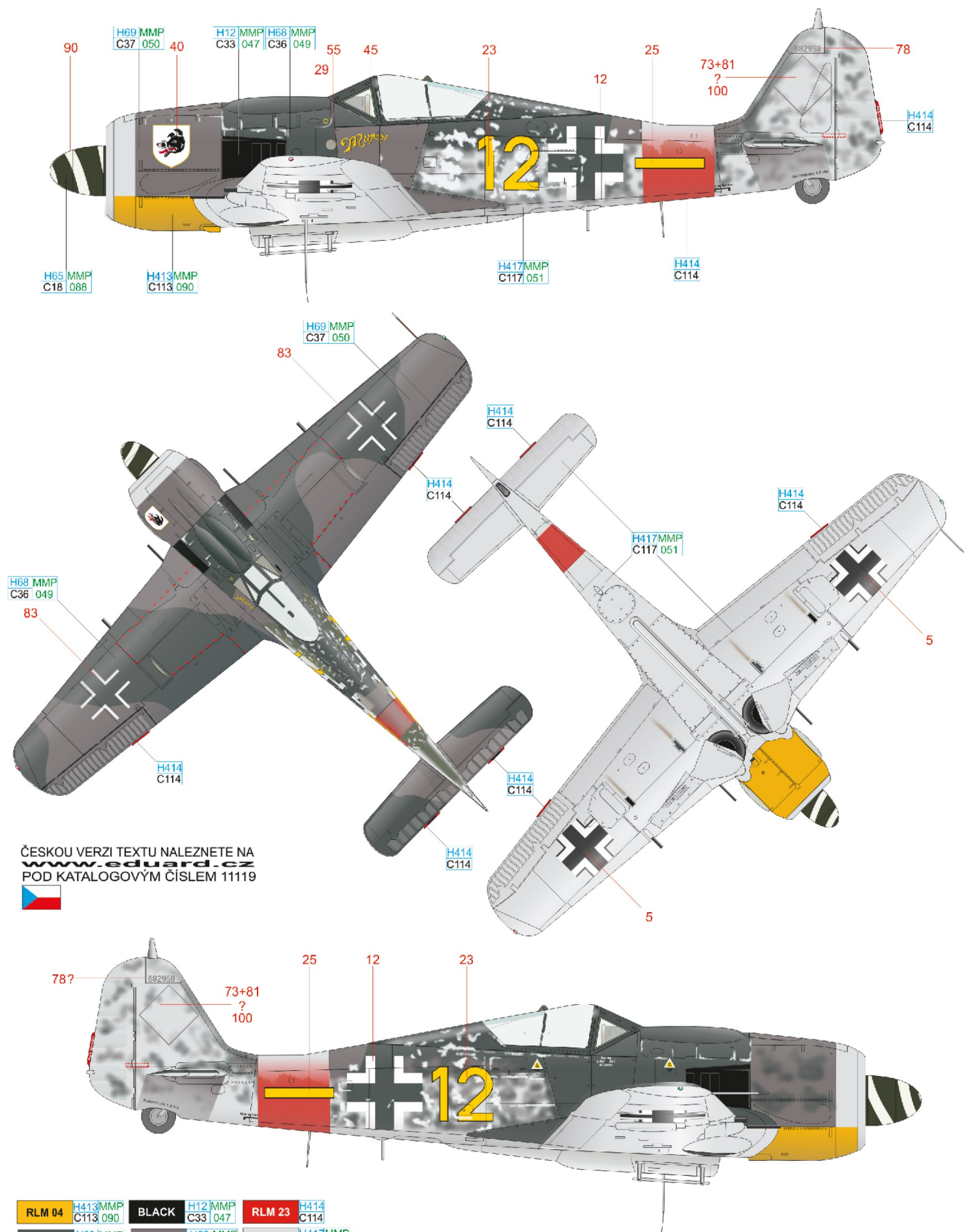

ČESKOU VERZI TEXTU NALEZNETE NA www.eduard.cz POD KATALOGOVÝM ČÍSLEM 11119



RLM 04	H413 MMP C113 090	BLACK	H12 MMP C33 047	RLM 23	H414 C114
RLM 74	H68 MMP C36 049	RLM 75	H69 MMP C37 050	RLM 76	H417 MMP C117 051

E Fw 190A-8/R2, W. Nr. 682204, flown by Oblt. Klaus Bretschneider, 5. (Sturm)/ JG 300, Löbnitz, Germany, December 1944.

Holder of the Knight's Cross and fighter ace Klaus Bretschneider was one of the founding pilots of II. Gruppe JG 300. He achieved fourteen kills before being trained in the Sturm tactics of attacking and would claim another twenty afterwards, the majority of which were four-engined heavy bombers. He fell as CO of 5./ JG 300 on December 24th, 1944 after an attack on a group of B-17s. He was the victim of escort fighters, likely from the 357th Fighter Group. His aircraft went down not far from Oberaul in Hesse. Bretschneider's Sturmbock, christened 'Rauhbautz VII', had the side armoured glass units removed on the sliding portion of the canopy. Markings of the aircraft of JG 300 within the Defence of the Reich, a red fuselage band ahead of the tail surfaces, was further complemented by a red horizontal bar for aircraft of the 5th Staffel. According to new sources, the inscription below the cockpit was yellow with red shadowing, the spinner carries a white spiral on a red background. This kit includes the newer interpretations as well as the more usual red with black shadowed inscription and black spinner and white spiral.

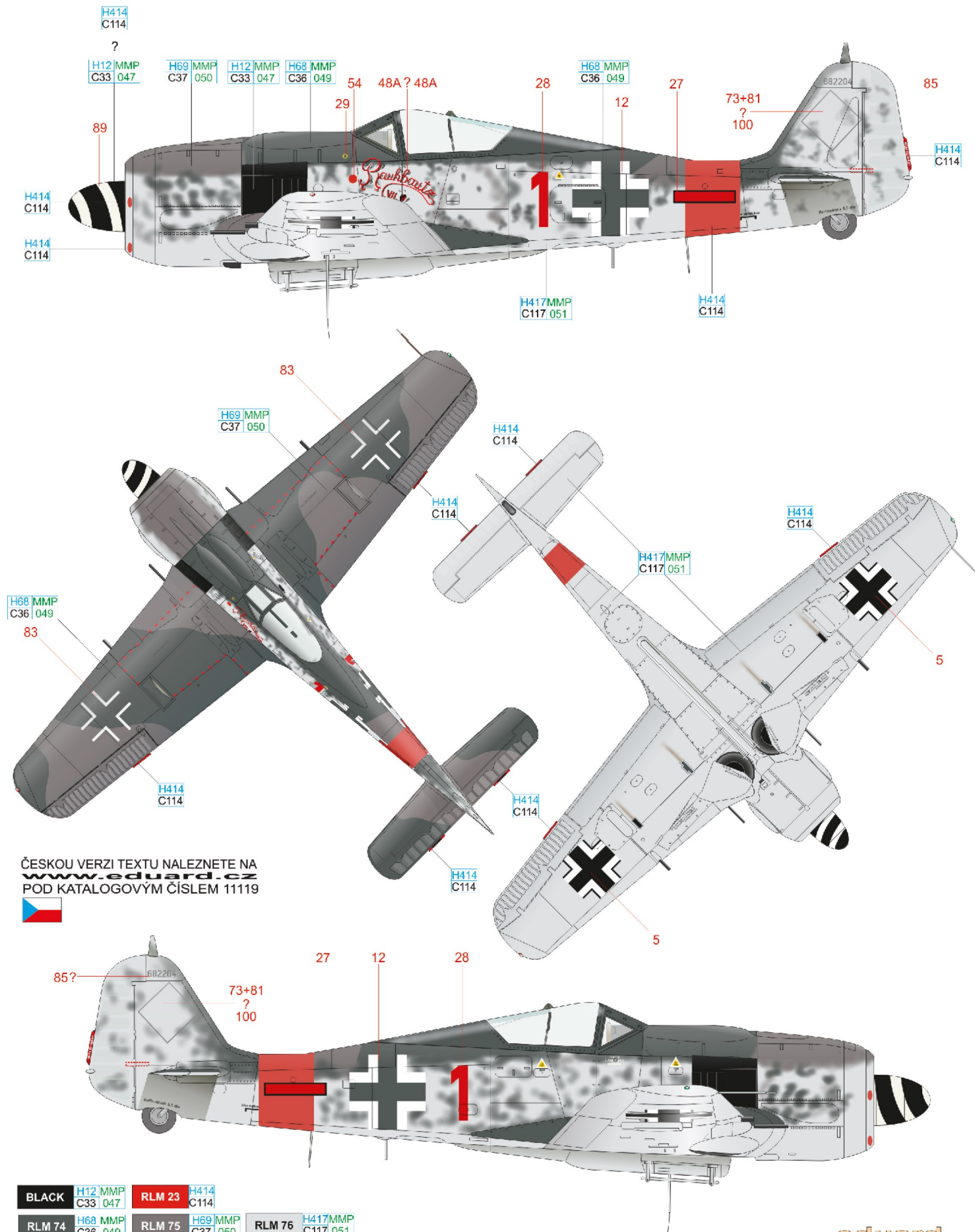

ČESKOU VERZI TEXTU NALEZNETE NA www.eduard.cz POD KATALOGOVÝM ČÍSLEM 11119



BLACK	H12 MMP C33 047	RLM 23	H414 C114
RLM 74	H68 MMP C36 049	RLM 75	H69 MMP C37 050
		RLM 76	H417 MMP C117 051

G Bf 109G-6/R6, W. Nr. 20272, flown by Oblt. Heinrich Klöpfer, CO of 7./ JG 1, Leeuwarden, the Netherlands, November 1943

A native of Lower Saxony's Peine, future Knight's Cross recipient Heinrich Klöpfer took part in the Battle of France and the Battle of Britain as a member of JG 77. He would claim one kill in each of these campaigns. He would get another eighty after the initiation of Operation Barbarossa on June 22nd, 1941 through to November 1943, this time with 11th Staffel of JG 51. At the beginning of November 1943, he took command of the 7th Staffel JG 1, a unit that was incorporated in the the Defence of the Reich (Reichsverteidigung). Serving with this unit, he downed five four engined B-17s, a B-24 and two P-38s. He was killed on November 29th, 1943, in combat with a couple of P-38s in the cockpit of his Bf 109 over Vollenhove in the Netherlands. Some commanders of tactical units had the fin and rudders of their aircraft painted white for quick identification of the leader's aircraft in combat. The rudder also bears Klöpfer's victory tally.

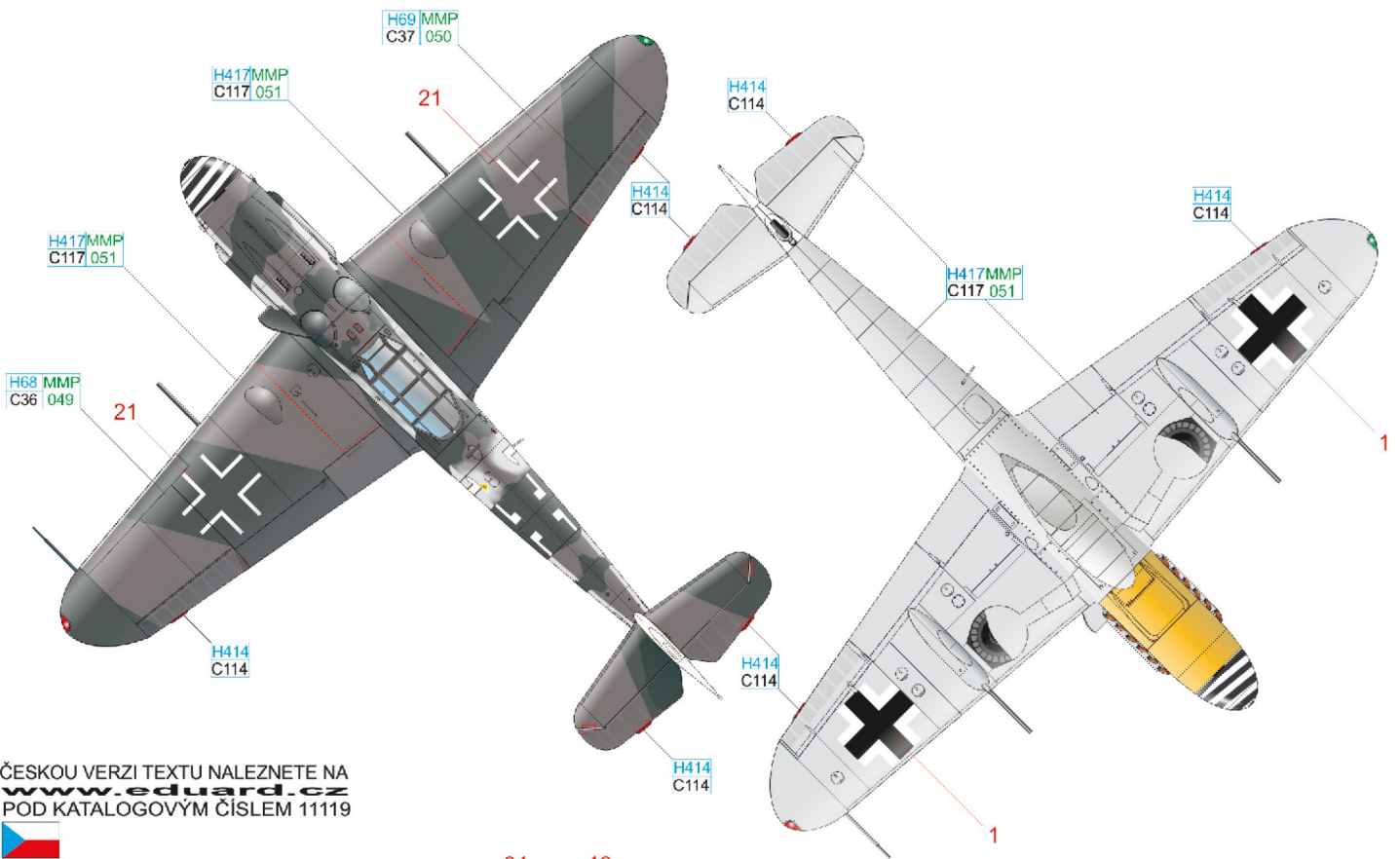
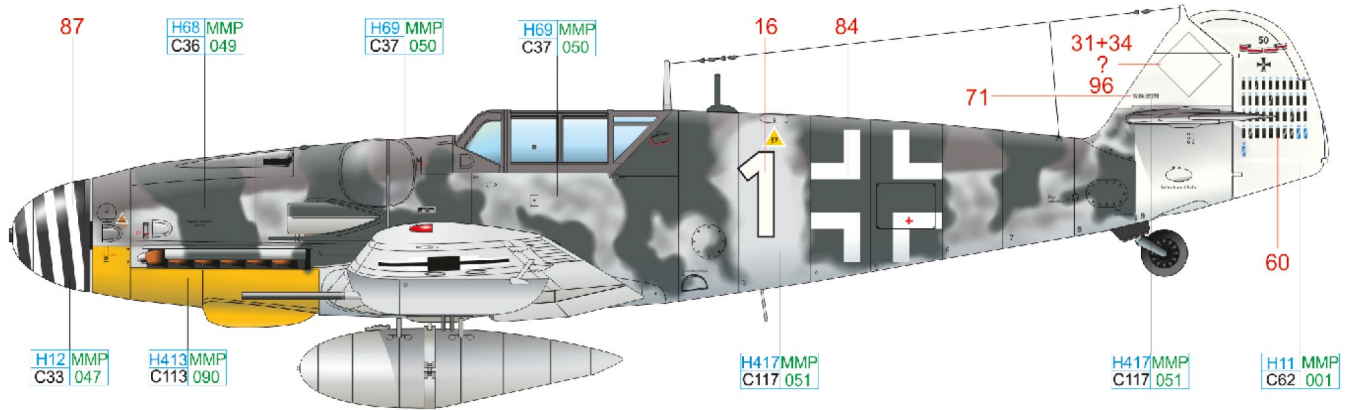

ČESKOU VERZI TEXTU NALEZNETE NA www.eduard.cz POD KATALOGOVÝM ČÍSLEM 11119

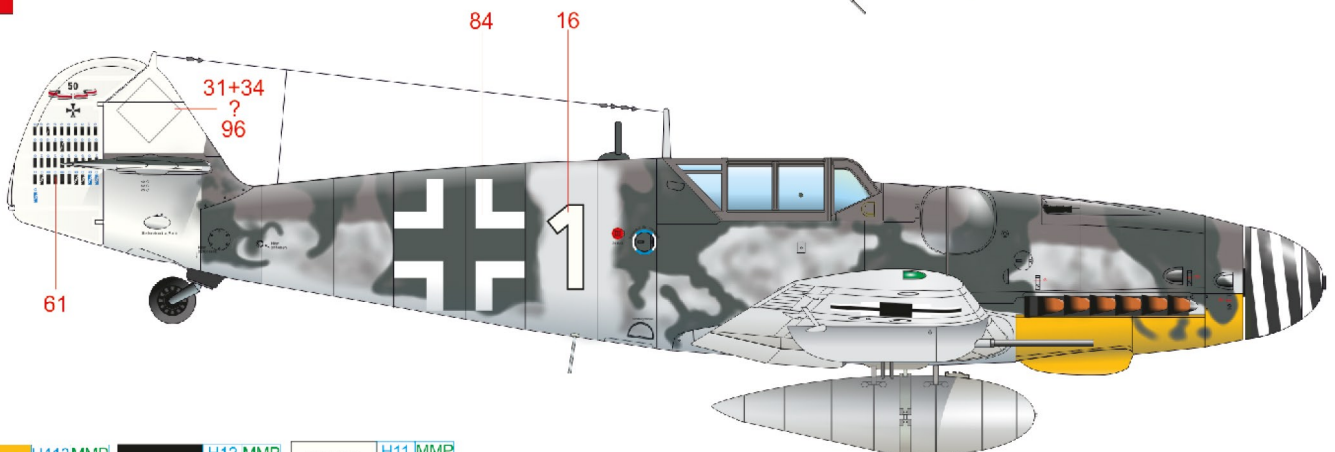

RLM 04	H413 MMP C113 090	BLACK	H12 MMP C33 047	WHITE	H11 MMP C62 001
RLM 74	H68 MMP C36 049	RLM 75	H69 MMP C37 050	RLM 76	H417 MMP C117 051
				RLM 23	H414 C114

H Bf 109G-6/R6, flown by Hptm. Anton Hackl, CO of III./ JG 11, Oldenburg, Germany, January 1944

After recovering from major injuries sustained in North Africa during combat with P-38s on February 4th, 1943, Anton Hackl returned to combat duty. At the time, he was already a 126 kill ace and holder of the Knight's Cross with Oak Leaves and was assigned to III./ JG 11, a unit incorporated into the Defence of the Reich. The following month, he was made CO of the unit. During his stint with JG 11, which ended in further injuries on April 15th, 1944 in combat with P-47s, he had amassed 141 kills. During his subsequent recuperation time, he was awarded the Swords of his Knight's Cross with Oak leaves. After recovery from these latest injuries, he would command other units of the Luftwaffe. History has recorded as Hackl shooting down a total of 192 enemy aircraft (34 of which were four-engined heavy bombers) and another 24 as unconfirmed. He died on July 9th, 1984 in his hometown of Regensburg. The aircraft flown by Anton Hackl was painted in the standard Luftwaffe day scheme as applied at the Messerschmitt factory in Regensburg. As was the case with Klöpffer's plane, the tail was painted in white for rapid identification of the CO's aircraft during combat. The rear of the fuselage carries the Defence of the Reich unit marking for JG 11, a 900 mm wide yellow band.

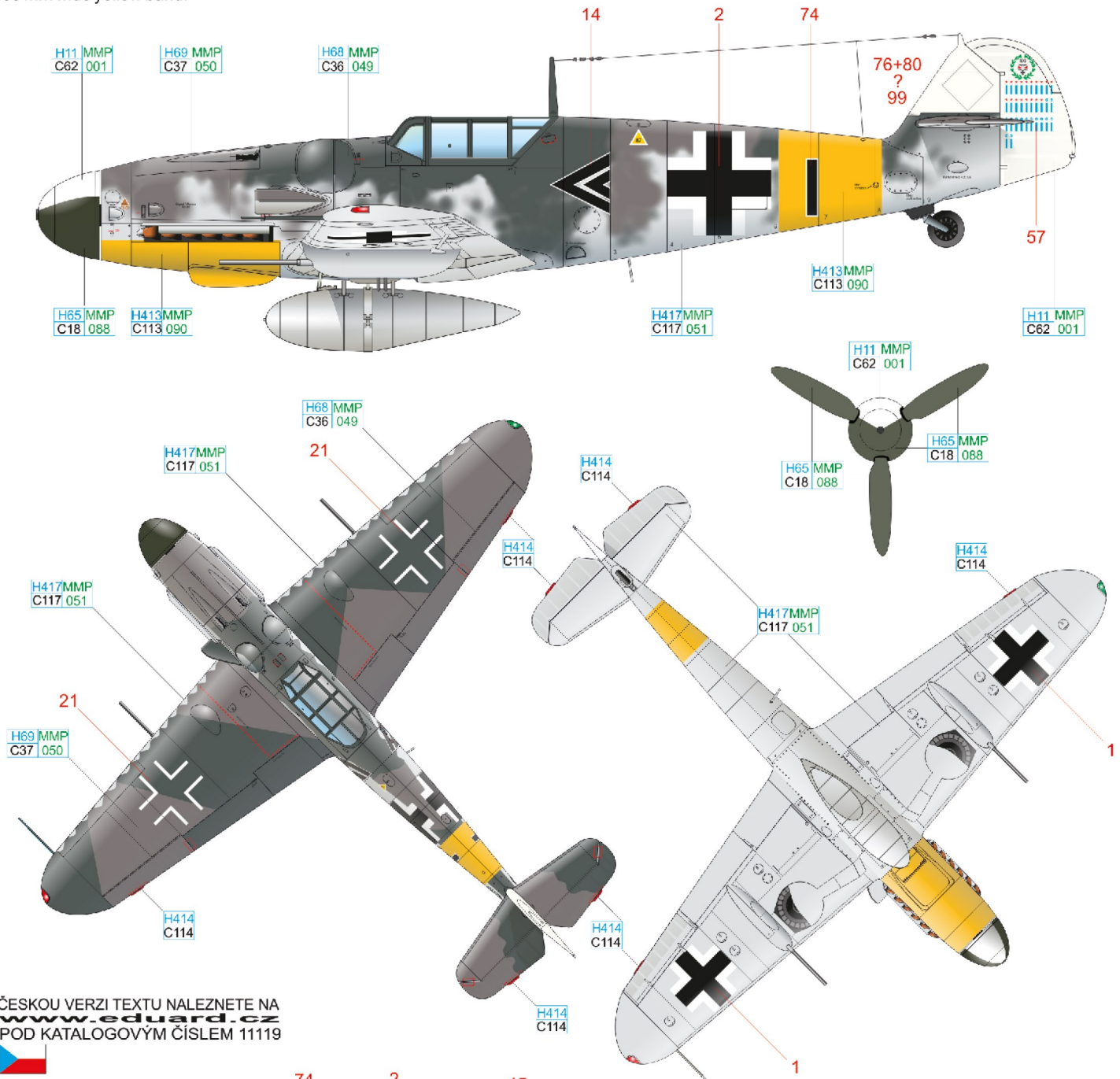

ČESKOU VERZI TEXTU NALEZNETE NA
www.eduard.cz
 POD KATALOGOVÝM ČÍSLEM 11119

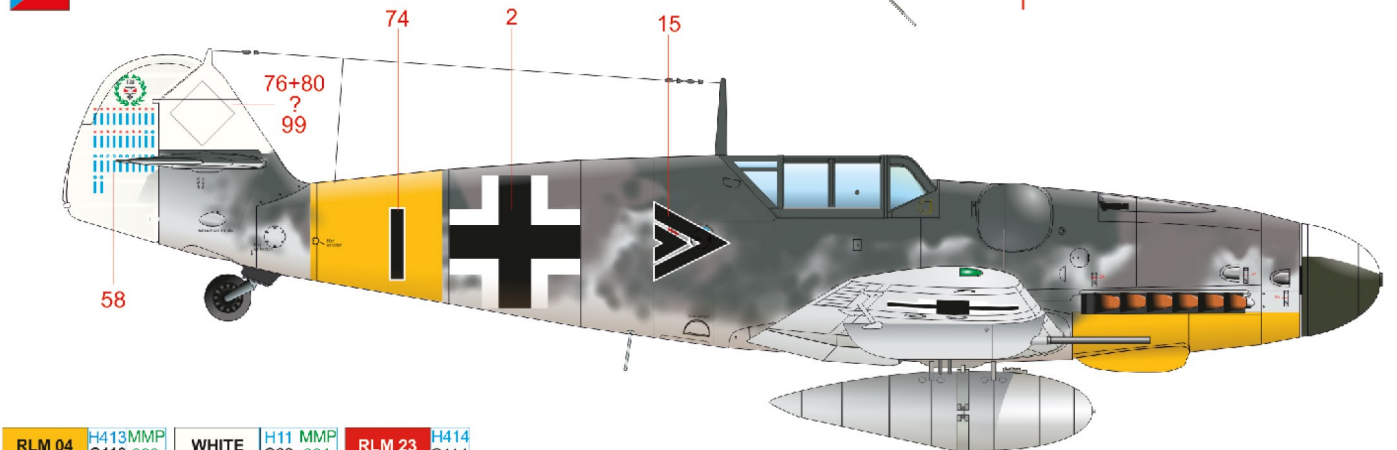

RLM 04	H413MMP C113 090	WHITE	H11 MMP C62 001	RLM 23	H414 C114
RLM 74	H68 MMP C36 049	RLM 75	H69 MMP C37 050	RLM 76	H417MMP C117 051
				RLM 70	H65 MMP C18 088

In November, 1942 I. Gruppe of JG 27 was withdrawn from North Africa and after essential downtime and replenishment of personnel and ground crew was reassigned to northern France in January 1943. A new combat environment and inexperienced personnel contributed to heavy losses during combat and it was therefore decided to transfer the unit to a less intense area, specifically to a base at Fels am Wagram, near Vienna. I./ JG27 was incorporated into the Defence of the Reich structure at the same time, tasked with protecting the area around Vienna against heavy bomber raids of the 9th Air Force. Here, the unit remained until being hastily recalled back to northern France on June 6th, 1944. 'Black 1', photographed in February 1944 at Trenčín, carries a camouflage scheme applied at the Erla manufacturing facility in Leipzig. It also carries the JG 27 unit marking in the Defence of the Reich, a 900 mm wide green fuselage band. The engine cowl also bears the JG 27 insignia. The base of the spinner wasn't painted black like the remainder of the item and remained in the colour originally painted in, with one-third in white and two-thirds in RLM 70 Schwarzgrün.

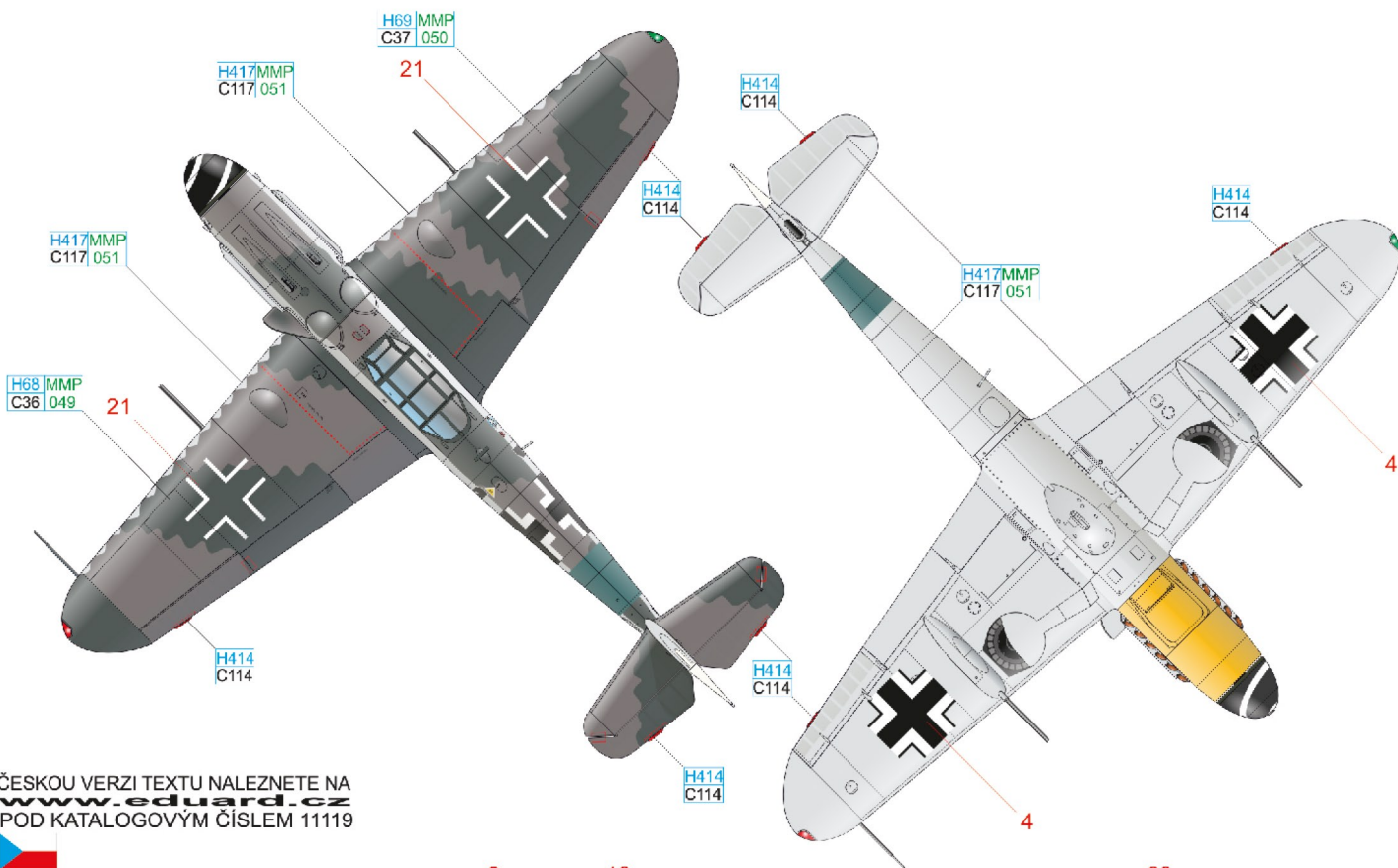
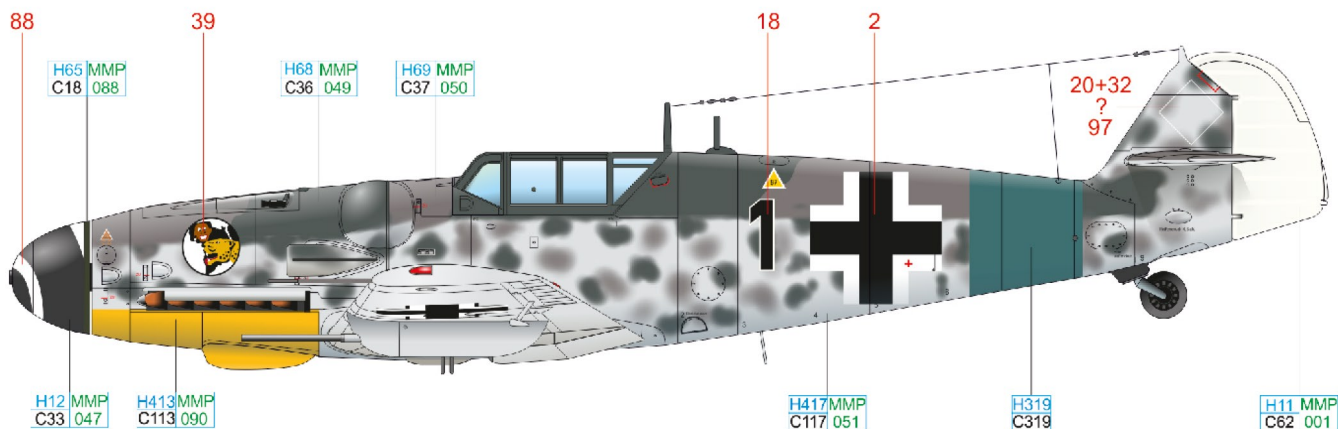

ČESKOU VERZI TEXTU NALEZNETE NA
www.eduard.cz
 POD KATALOGOVÝM ČÍSLEM 11119

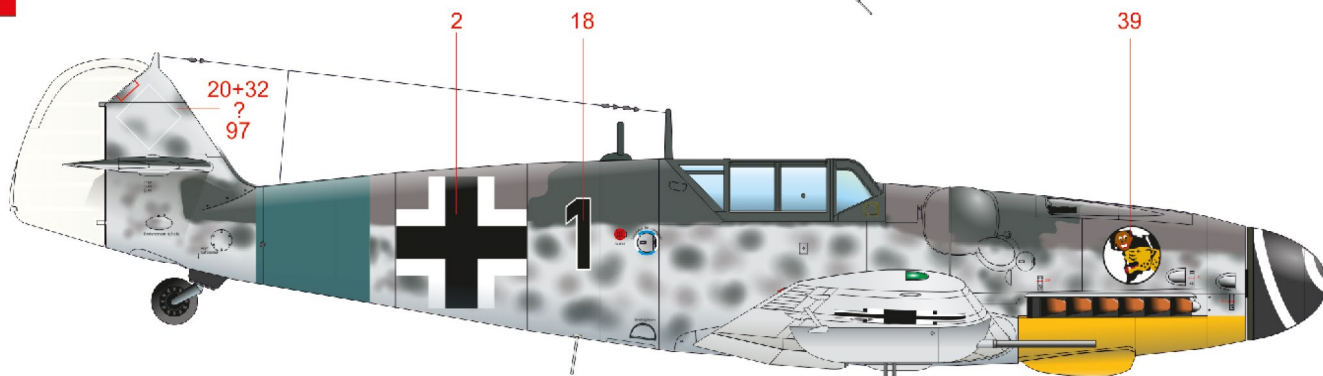

RLM 04	H413 MMP C113 090	BLACK	H12 MMP C33 047	WHITE	H11 MMP C62 001	RLM 23	H414 C114
RLM 74	H68 MMP C36 049	RLM 75	H69 MMP C37 050	RLM 76	H417 MMP C117 051	RLM 70	H65 MMP C18 088
						LIGHT GREEN	H319 C319

In February 1943, III. Gruppe JG 54 Grünherz was moved to the Western Front in an effort to strengthen the fighter force in combat against the increasing significance of the RAF complimented by American units. Later, it was transferred from the Canal zone and incorporated into the Defence of the Reich structure, where their main opposition consisted of four-engined B-17 Flying Fortress and B-24 Liberator heavy bombers escorted by P-38 Lightnings, P-47 Thunderbolts and P-51 Mustangs. 'Yellow 9' bore the standard RLM74/75/76 scheme applied on the production line by Messerschmitt at Regensburg also had a yellow rudder and spinner. The III. Gruppe unit identifier appeared on the 900 mm wide blue fuselage band. Its yellow colour was reserved for machines of the 9th Staffel. The 9th Staffel JG 54 unit insignia was placed on the nose of the aircraft and the III. Gruppe marking below the cockpit.

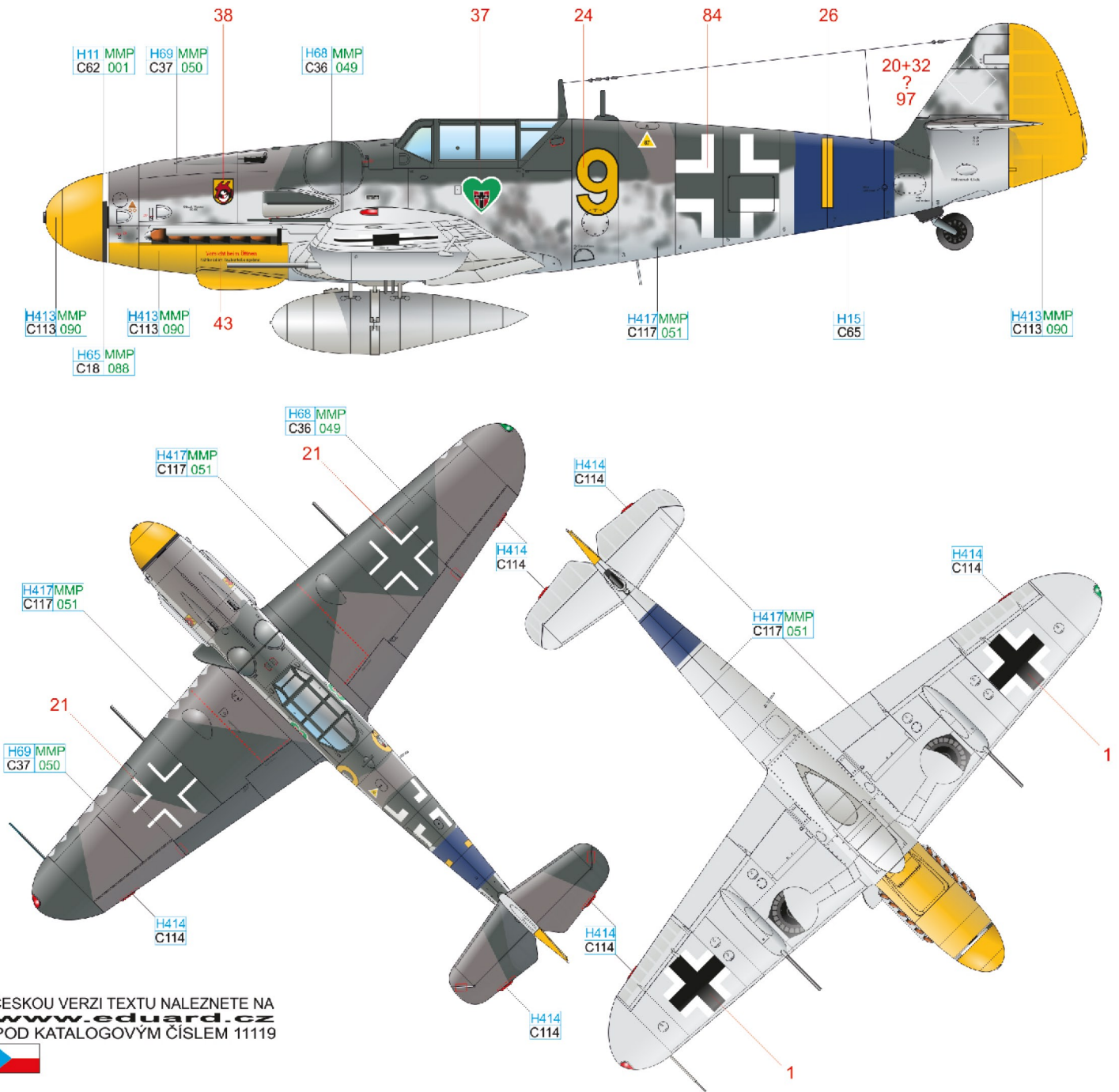

ČESKOU VERZI TEXTU NALEZNETE NA
www.eduard.cz
 POD KATALOGOVÝM ČÍSLEM 11119

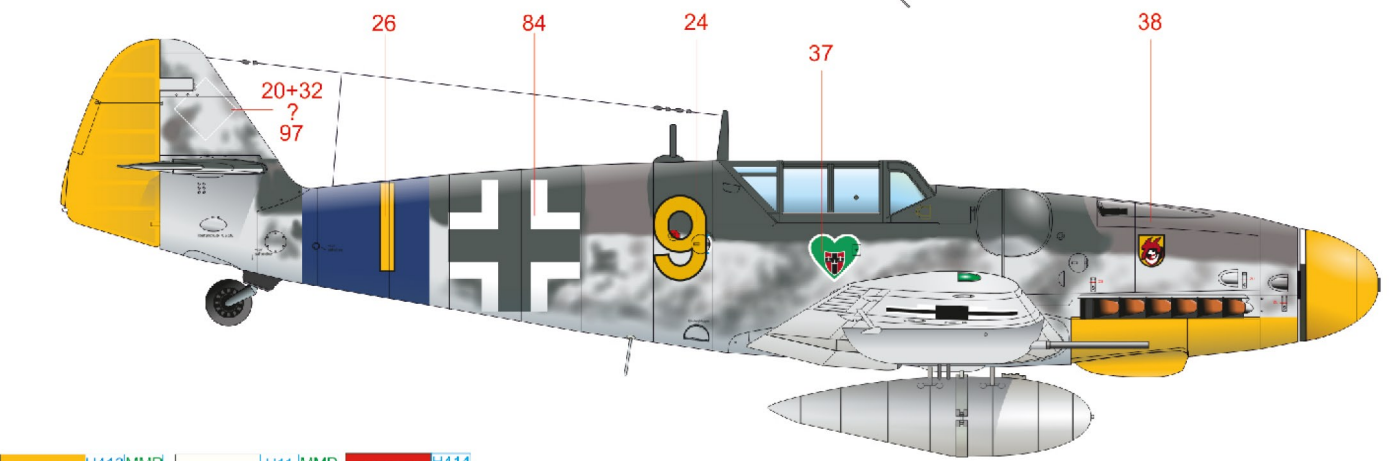

RLM 04	H413 MMP C113 090	WHITE	H11 MMP C62 001	RLM 23	H414 C114
RLM 74	H68 MMP C36 049	RLM 75	H69 MMP C37 050	RLM 76	H417 MMP C117 051
				RLM 70	H65 MMP C18 088
				RLM 24	H15 C65

K Bf 109G-6, flown by Uffz. Klaus Lambio, 9./ JG 300, Jüterbog – Waldlager, Germany, June 1944

Jagdgeschwader 300 was originally tasked with night interceptions of British bombers using single engined Bf 109 and Fw 190A fighters. At the end of May 1944, it was decided to integrate these assets into day units as part of the Defence of the Reich structure. Uffz. Klaus Lambio, who began to meet USAAF four-engined heavy bombers in combat from June 1944, was able to destroy or damage seven of them over the remaining eleven months of the war. This aircraft carries a red 900 mm wide fuselage band over the rear fuselage and is camouflaged in the standard RLM 74/75/76 scheme as applied at Erla in Leipzig. The red band identified the aircraft as belonging to JG 300. This identifier was used by JG 300 until January 1945 when it was changed to a blue-white-blue band of the same width. The airplane has the new type of canopy called 'Erla haube' and a tall rudder.

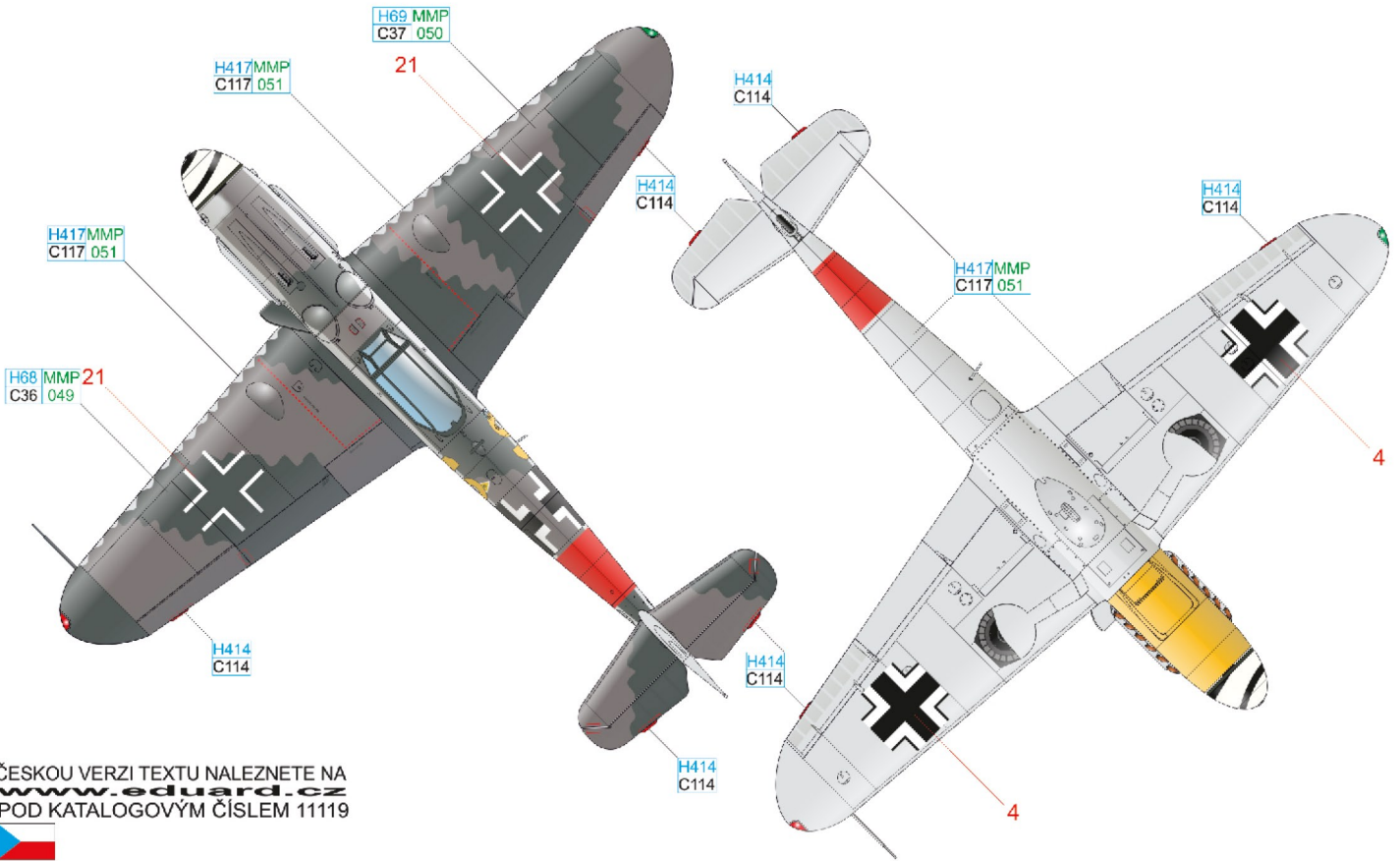
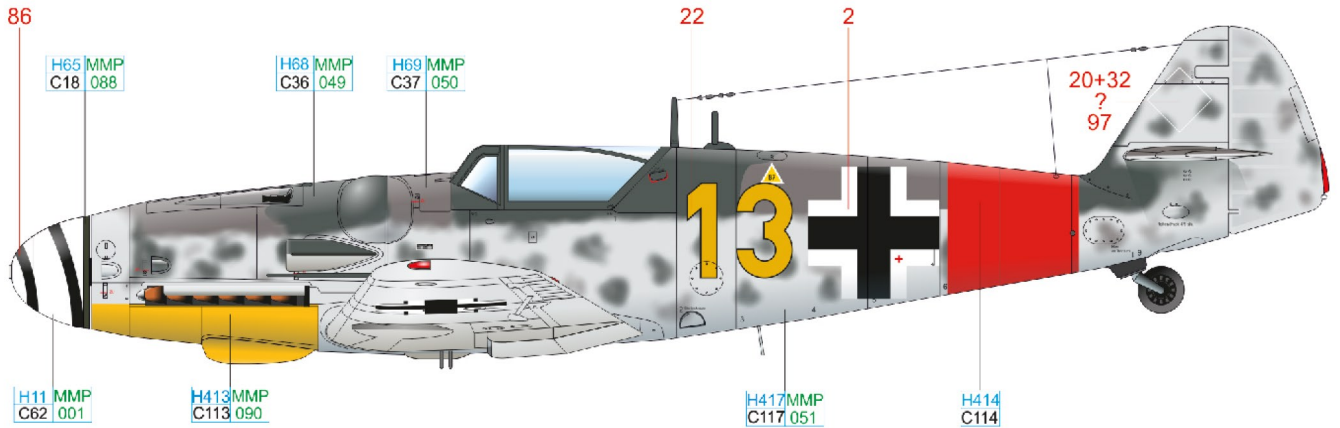

ČESKOU VERZI TEXTU NALEZNETE NA
www.eduard.cz
 POD KATALOGOVÝM ČÍSLEM 11119

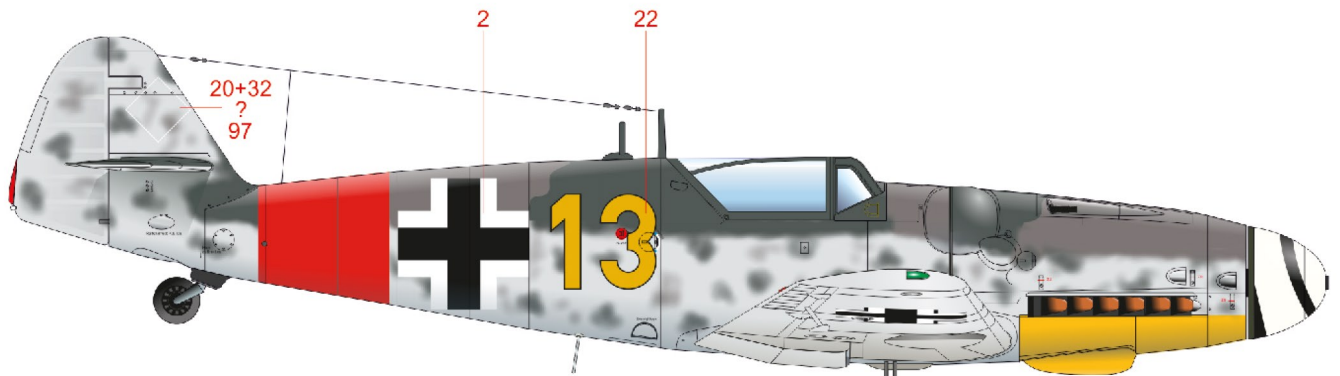

RLM 04	H413 MMP C113 090	BLACK	H12 MMP C33 047	WHITE	H11 MMP C62 001	RLM 23	H414 C114
RLM 74	H68 MMP C36 049	RLM 75	H69 MMP C37 050	RLM 76	H417 MMP C117 051	RLM 70	H65 MMP C18 088

The area of operations for I. Gruppe JG 77 from mid 1942 was the Southern Front, where together with sister units II. and III. Gruppe they fought against the Allies first in Africa, then in Italy and the Balkans. At the beginning of 1945, the entire Jagdgeschwader 77 was integrated into the Defence of the Reich, where their main task was to combat American four-engine heavy bombers and their escorts on their way to German targets. Over the final months of the war, the unit was moved to northern Moravia where they engaged Soviet pilots. Bf 109G-14 'Yellow 10' was discovered by the Allies at the airfield of Euskirchen in Germany. The 900 mm green and white fuselage band put this aircraft with JG 77 in the Defence of the Reich structure. It is possible that this aircraft had a cowl that was produced by Erla in Leipzig.

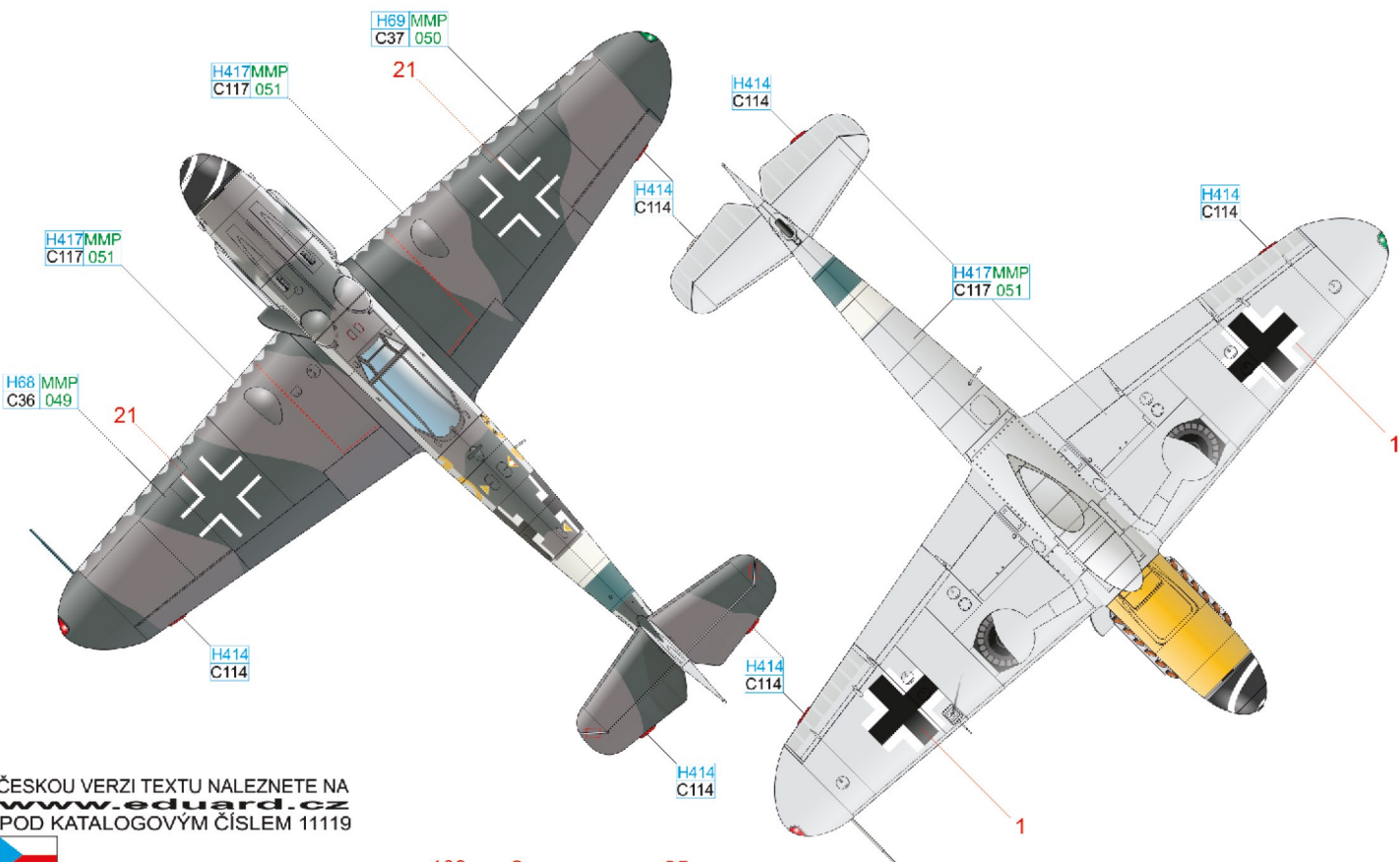
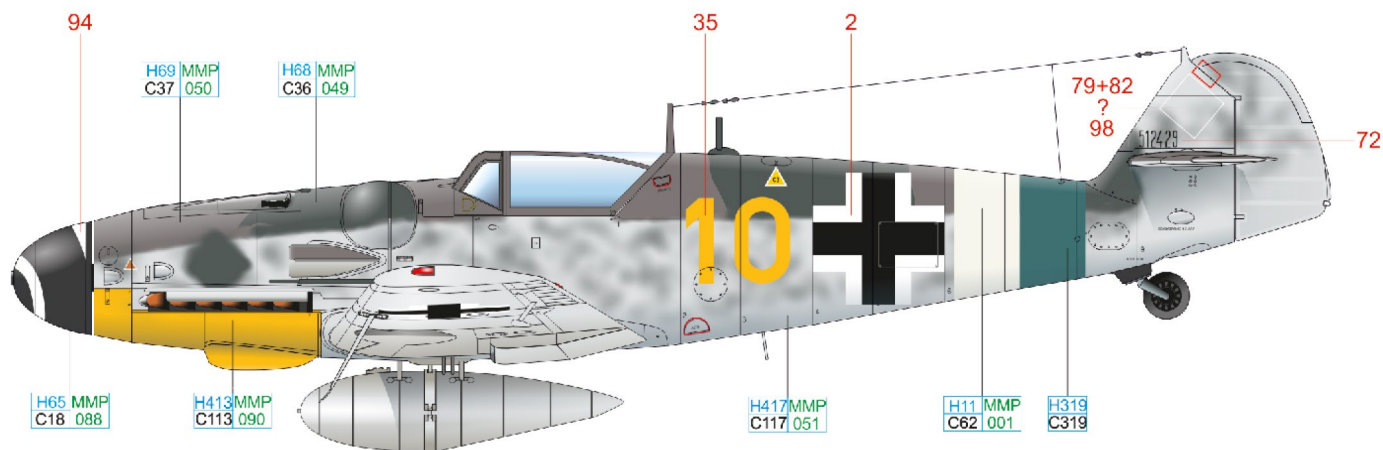

ČESKOU VERZI TEXTU NALEZNETE NA www.eduard.cz POD KATALOGOVÝM ČÍSLEM 11119

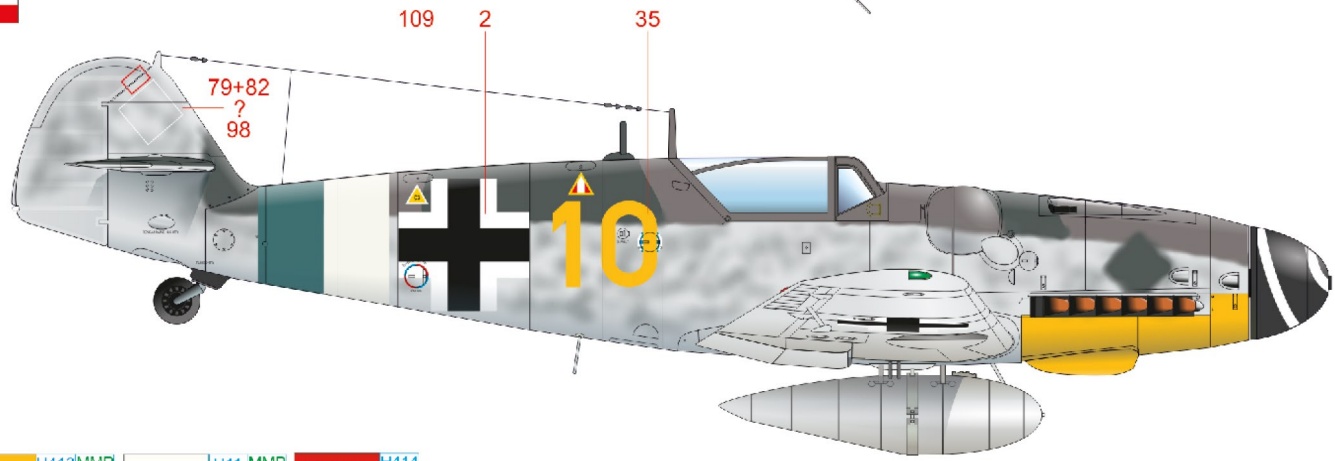

RLM 04	H413 MMP C113 090	WHITE	H11 MMP C62 001	RLM 23	H414 C114
RLM 74	H68 MMP C36 049	RLM 75	H69 MMP C37 050	RLM 76	H417 MMP C117 051
				RLM 70	H65 MMP C18 088
					LIGHT GREEN H319 C319

M Bf 109G-14, 13./ JG 53, Bad Wörishofen, Germany, 1945

IV. Gruppe JG 53 was formed out of III. Gruppe JG 76 at Hufingen, not far from the border with Switzerland at the end of October 1944 and was equipped with later versions of the Bf 109G. Later, the unit also was equipped with the more modern Messerschmitt Bf 109K. As a Defence of the Reich unit, it fought over the southern sector of the Western Front until the end of April 1945, when it was disbanded. 'Black 30' was discovered by advancing Allied troops at Bad Wörishofen. The rear fuselage had a 900 mm wide black fuselage band, an identifier used by JG 53 when in the Defence of the Reich system. The wave bar on the rear fuselage was reserved for aircraft of the IV. Gruppe.

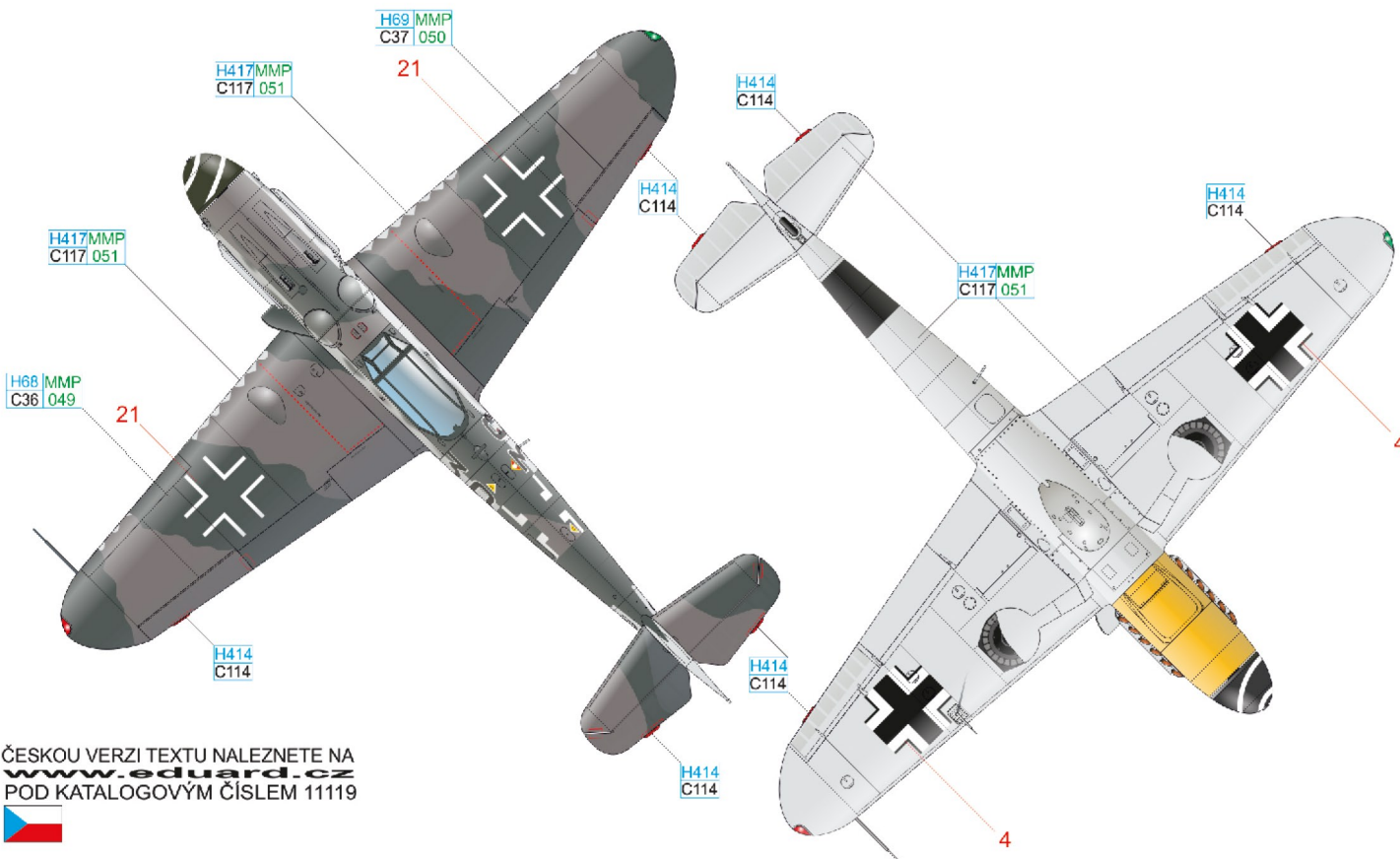
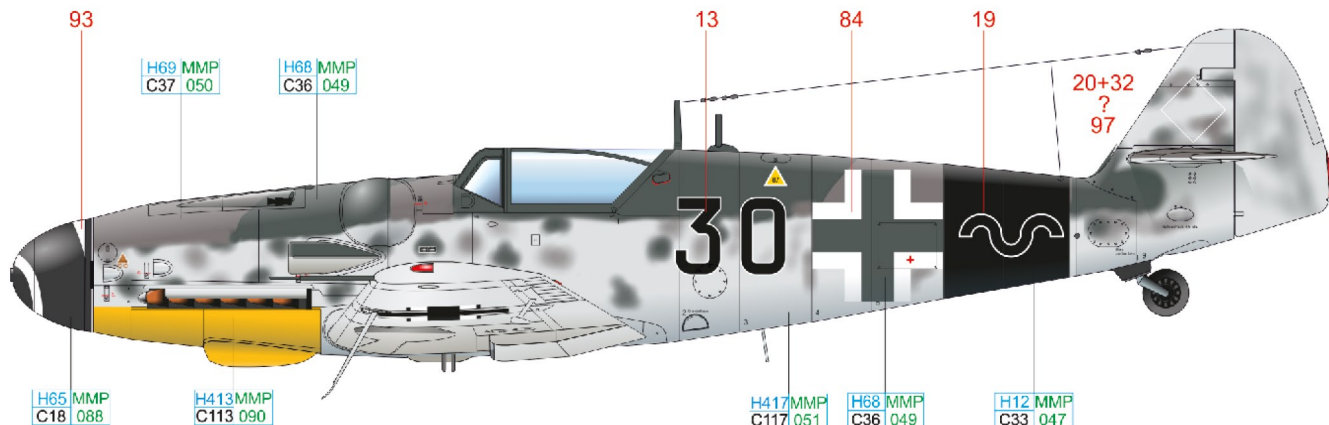

ČESKOU VERZI TEXTU NALEZNETE NA
www.eduard.cz
 POD KATALOGOVÝM ČÍSLEM 11119

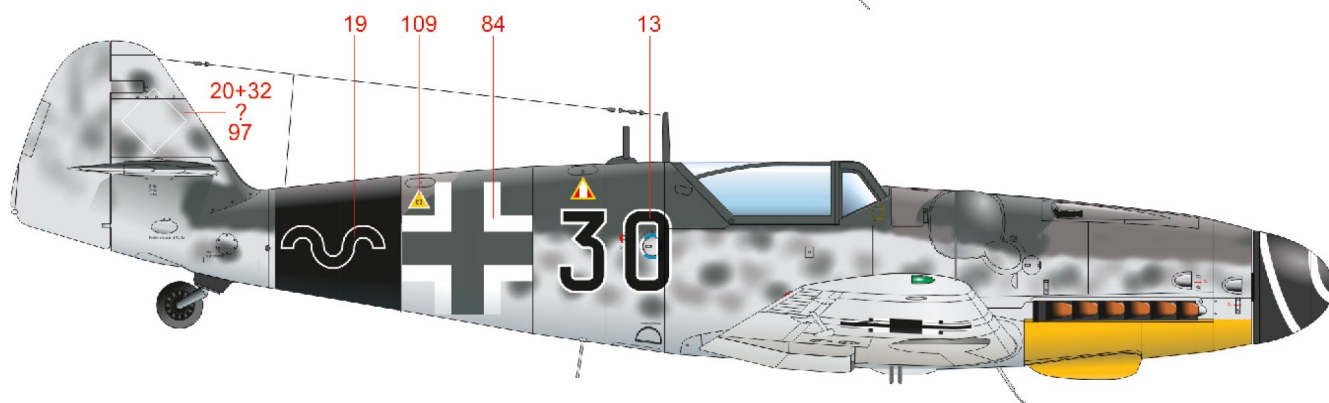

RLM 04	H413 MMP C113 090	BLACK	H12 MMP C33 047	RLM 23	H414 C114
RLM 74	H68 MMP C36 049	RLM 75	H69 MMP C37 050	RLM 76	H417 MMP C117 051
				RLM 70	H65 MMP C18 088

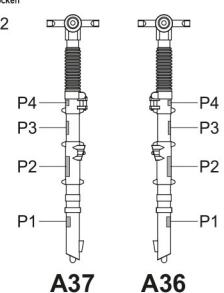
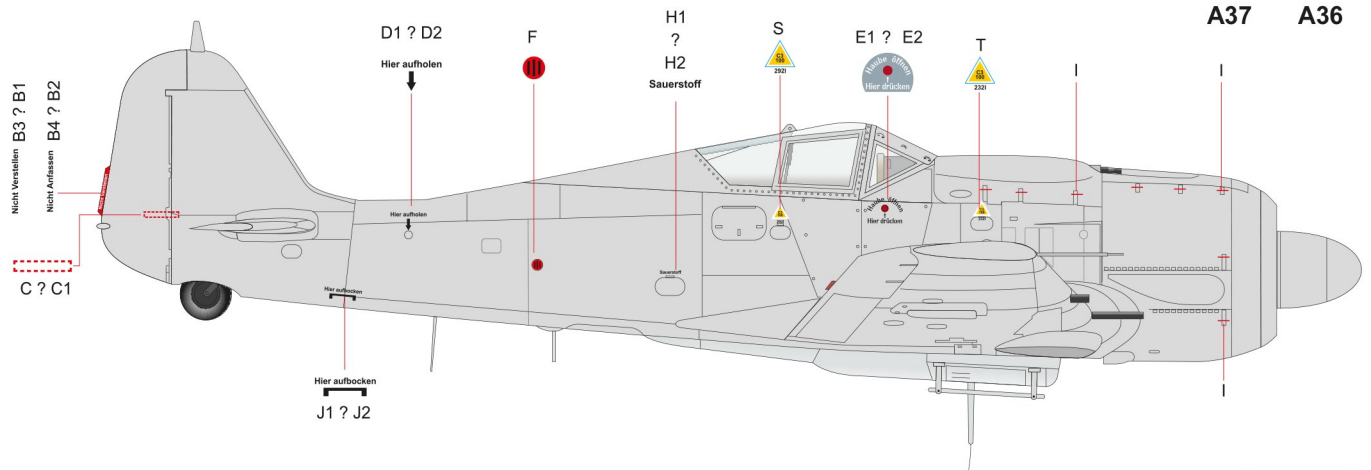
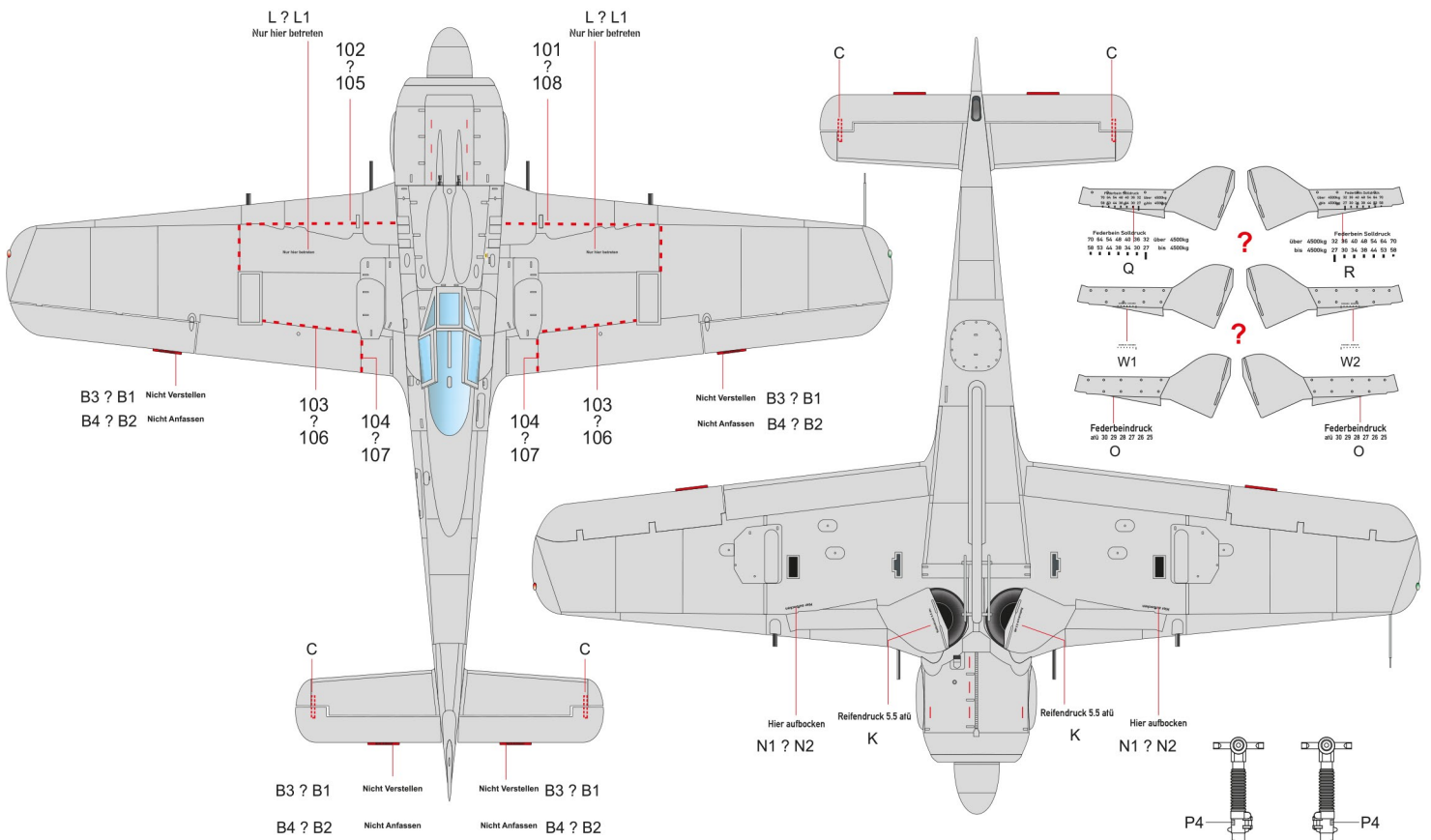
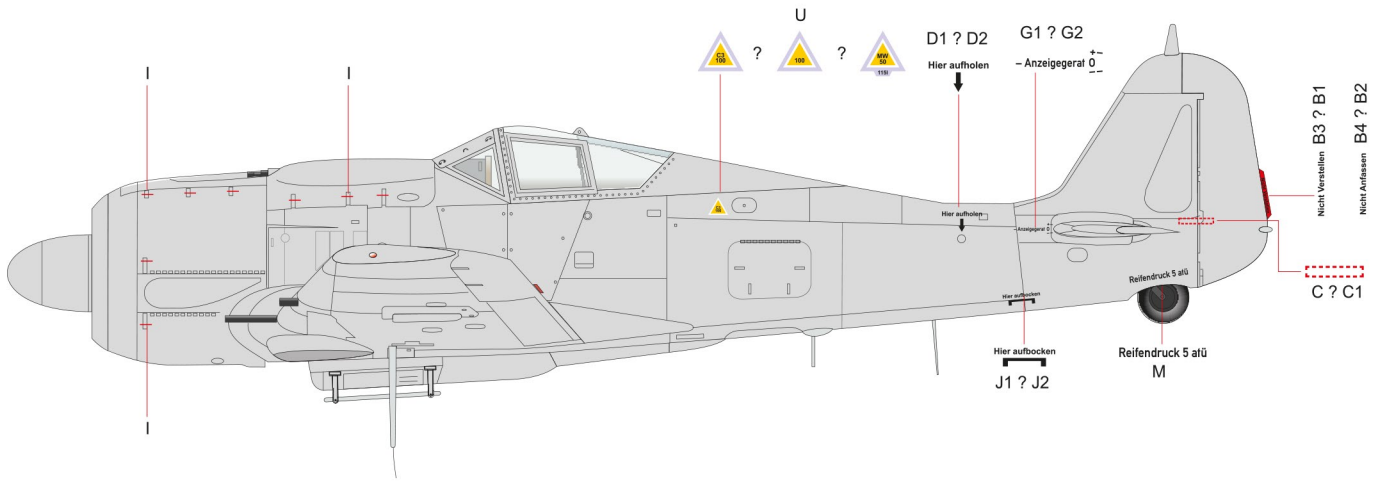

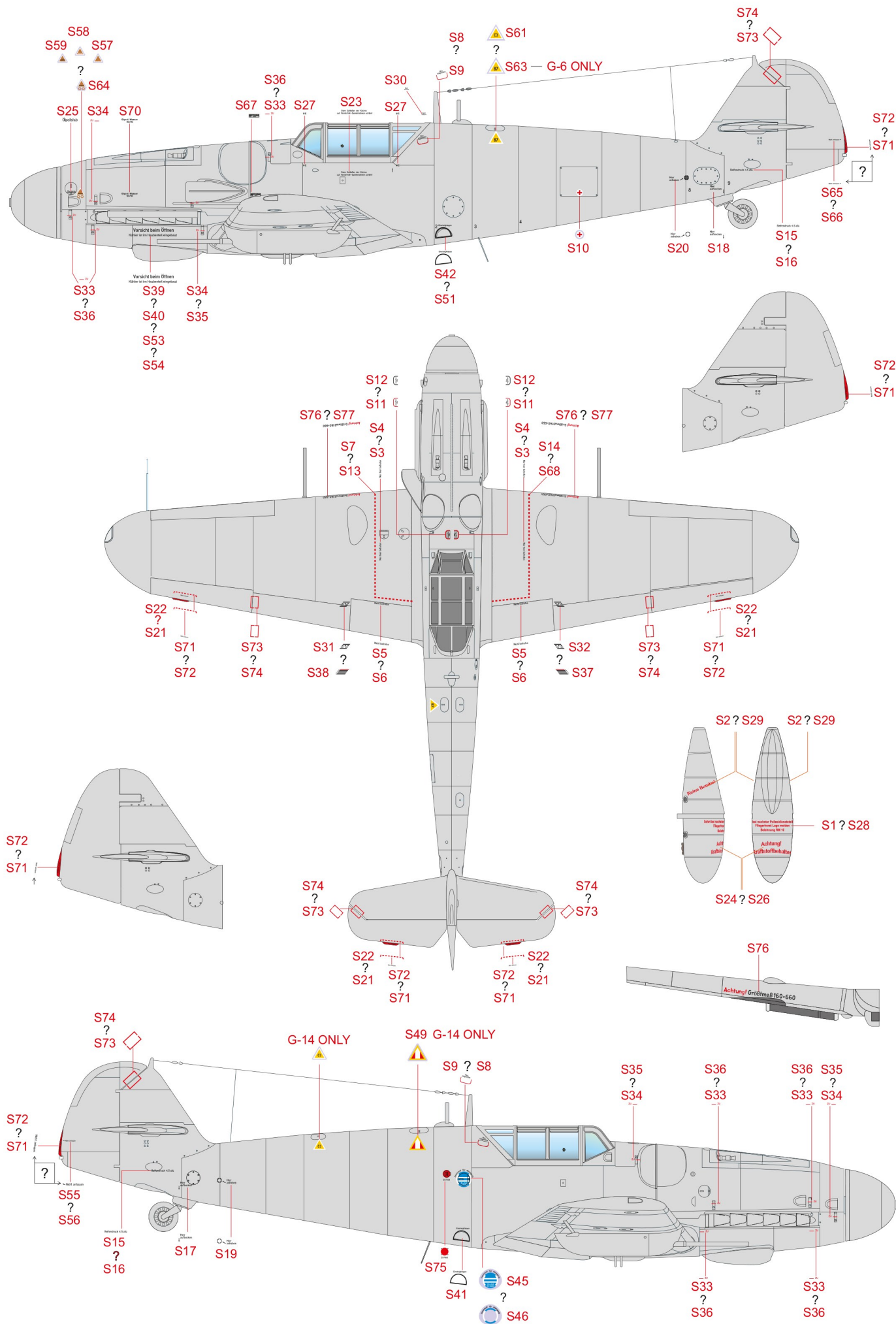

RELATED PRODUCTS for Fw 190A-8/R2:

- FE863 Fw 190A seatbelts STEEL 1/48 (PE-set)
- 648356 Fw 190A wingroot gun bays 1/48 (Brassin)
- 648366 Fw 190A propeller 1/48 (Brassin)
- 648381 Fw 190A exhaust stacks 1/48 (Brassin)
- 648426 Fw 190A-8/R2 cockpit 1/48 (Brassin)

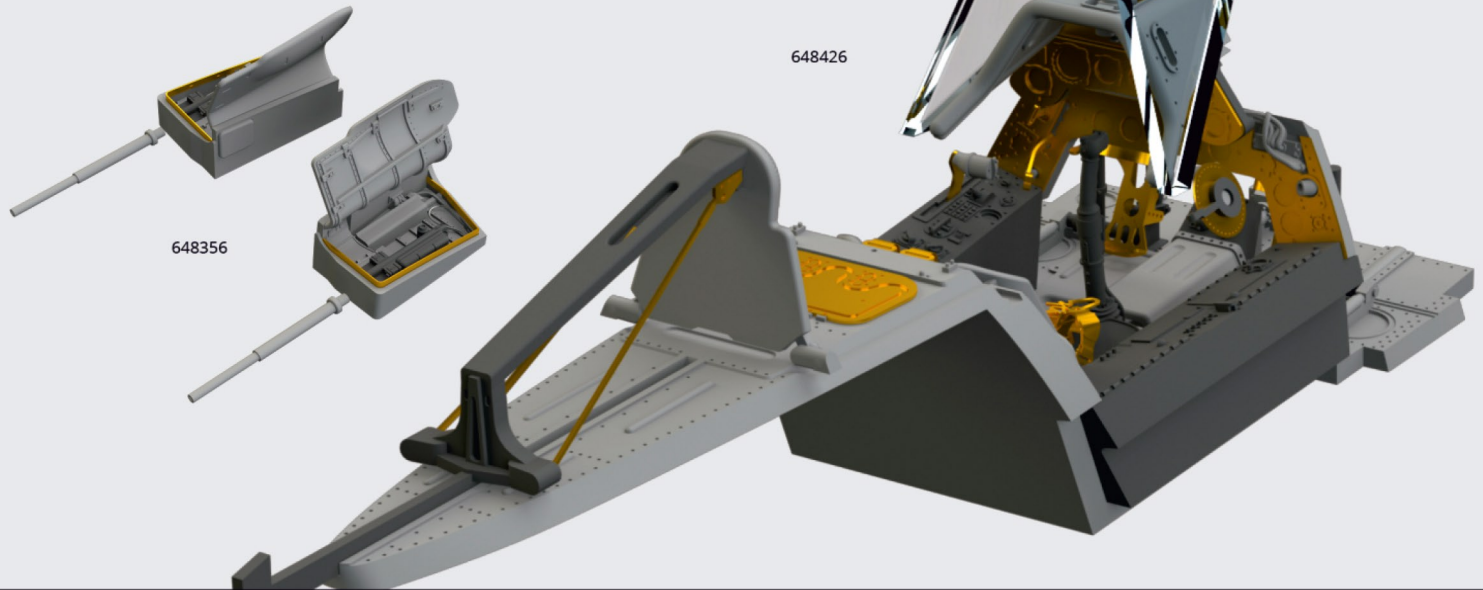

RELATED PRODUCTS for Bf 109G-6/14:

- 48885 Bf 109G-6 (PE-set)
- 48942 Bf 109G-14 (PE-set)
- 49093 Bf 109G seatbelts FABRIC (PE-set)
- 49094 Bf 109G seatbelts SUPERFABRIC (PE-set)
- 648239 Bf 109G-6 radio compartment (Brassin)
- 648240 Bf 109G-6 cockpit (Brassin)
- 648245 W.Gr.21 for Bf 109 (Brassin)
- 648246 Bf 109 cannon pods (Brassin)
- 648247 Bf 109G exhaust stacks (Brassin)
- 648265 Bf 109G external fuel tanks (Brassin)
- 648309 Bf 109G undercarriage legs BRONZE (Brassin)
- 648310 Bf 109G control surfaces (Brassin)
- 648332 Bf 109F and G Pitot tubes (Brassin)
- EX509 Bf 109G camo scheme - Mtt (Mask)
- EX510 Bf 109G camo scheme - Erla (Mask)
- EX511 Bf 109G camo scheme - WNF (Mask)
- EX512 Bf 109G spinner spirals (Mask)

