

DEUTSCH: ACHTUNG: Vor dem Zusammensetzen die Bauanleitung gut durchlesen. Jedes Teil ist nummeriert. Reihenfolge der Montageschritte beachten. Benötigte Werkzeuge: Messer und Feile zum Entfernen und Entgraten der Teile, Gummiband, Klebeband und Wäscheklammern zum Zusammenhalten der geklebten Einzelteile. Plastikteile in einer milden Waschmittellösung reinigen und an der Luft trocknen, damit der Farbstrich und die Abziehbilder besser haften. Vor dem Ankleben prüfen, ob die Teile passen; Klebstoff sparsam auftragen. Chrom und Farbe an den Klebeflächen entfernen. Kleine Teile anstreichen, bevor sie vom Rahmen entfernt werden. Farben gut durchrocknen lassen, erst dann den Zusammenbau fortsetzen. Jedes Abziehbildmotiv einzeln ausschneiden und ca. 20 Sekunden in warmes Wasser tauchen. Das Motiv an der bezeichneten Stelle vom Papier abschieben und mit Löschpapier andrücken.

ENGLISH: ATTENTION: Carefully read instruction sheet before assembling. Each part is numbered. Consider succession of assembly steps. Required tools: knife and file to remove and trim parts; rubber band, adhesive tape and clothes pegs to hold parts after cementing. Wash plastic in mild detergent solution, rinse and let air dry for better paint and decal adhesion. Scrape chrome and paint at area to be glued: Paint small parts on runner before removing. Allow paint to dry thoroughly before continuing assembly. Cut out each decal one by one and dip it in warm water for approx. 20 secs.; slide decal from the paper at the marked position and dab with blotting-paper.

FRANCAIS: ATTENTION: lire soigneusement la fiche d'instructions avant d'assembler. Chaque pièce est numérotée. Suivre la succession des étapes de montage. Outils nécessaires: couteau et lime pour détacher et ébarber les pièces, élastiques, papier adhésif et pinces à linge pour maintenir ensemble les pièces après collage. Laver le plastique dans une solution détergente légère, rincer et laisser sécher à l'air libre pour une meilleure adhérence de la peinture et des décalés. Ajuster les pièces ensemble avant de coller. Employer la colle Revell pour plastique exclusivement. Utiliser très peu de colle à chaque fois. Gratter le chrome ou la peinture sur les surfaces à coller. Ajuster les petites pièces sur le support avant de les détacher. Laisser la peinture sécher totalement avant de continuer l'assemblage. Découper chaque décal séparément et le plonger dans l'eau chaude environ 20 secondes. Faire glisser le décal du papier à l'endroit du décor et tamponner avec du papier buvard.

NETERLANDS: OPGELET: alvorens te beginnen met het in elkaar zetten, eerst de handleiding goed doorlezen. Elk onderdeel is genummerd. Aandacht besteden aan de volgorde van montage. Het benodigde gereedschap: mesje en vijl voor het verwijderen en het afbramen van de onderdelen, elastiek, plakband en wasknijpers gebruiken voor het bij elkaar houden van de gelijmde onderdelen. De plastic onderdelen met een zacht wasmiddel schoonmaken en laten drogen zodat de verf en de transfers beter hechten. Alvorens te lijmen, eerst vaststellen of de onderdelen

passen; de lijm zuinig opbrengen. Chrom en verf van de op elkaar te lijmen delen verwijderen. Kleine onderdelen verven vóór deze van het gietraam verwijderd worden. De verf goed laten drogen en eerst dan verder gaan met de bouw. Elk transfer apart uitknippen en ca. 20 seconden in lauwwarm water leggen. Het transfer op de juiste plaats van het papier schuiven op het model en met vloeipapier aandrukken.

SVENSKA: VIKTIGT: Läs noggrant igenom instruktionerna innan du börjar bygga. Varje del är numrerad. Tänk igenom ordningsföljden för de olika momenten. Följande verktyg krävs: kniv och fil för att ta loss och putsa detaljerna, gummiband, tejp och klädnyppor för att hålla detaljerna på plats medan limmet torkar. Tvätta alla plastdetaljerna i mild tvålösning, skölj och låt lufttorka för att få färg och dekalerna att fästa bättre. Proppassa alltid detaljerna innan du limmar. Använd endast Revells plastlim. Använd sparsamt med lim. Skrapa bort krom och färg från den yta som ska limmas: måla smådetaljerna innan du skär loss dem. Låt all färg torka ordentligt innan du fortsätter byggandet. Skär ut varje dekal för sig och blöt den i ljummet vatten i ungefär 20 sekunder, och låt dekalen glida av papperet och ner på det markerade läget: sug sedan försiktigt upp det mesta vattnet med läskpapper eller en tygrasa.

ITALIANO: Attenzione: Leggere attentamente le istruzioni prima dell'assemblaggio. Ogni pezzo è numerato. Tener presente la successione delle fasi di assemblaggio. Attrezzi necessari: coltello e lima per rimuovere e rifinire le parti elastiche nastro adesivo e spilli per tenere le parti dopo averle incollate. Lavare la plastica con un detergente delicato, sciacquare e lasciare asciugare all'aria per una migliore adesione della vernice e delle 'decal'. Accoppiare le parti da incollare. Usare solamente 'Revell plastic cement'. Usare poco collante. Grattare la cromatura e la vernice nei punti da incollare. Dipingere i piccoli accessori sul supporto prima di rimuoverli. Far seccare bene la vernice prima di continuare nell'assemblaggio. Ritagliare una per una le 'decal' ed immergerle in acqua tiepida per circa 20 secondi. Applicare ogni 'decal' nella posizione segnata e tamponare con della carta assorbente.

ESPAÑOL: ATENCION: cuidadosamente lean la hoja de instrucciones antes del montaje. Cada pieza es numerada, consideren la sucesion de las operaciones de montaje. Herramientas requeridas: cuchilla y lima para quitar y desbarbar las piezas, banda de caucho, cinta adhesiva y pinzas para sujetar las piezas, despues de engomarmas. Lavar el plastico en solucion detergente suave, aclarar y dejar que se seque al aire para una mejor adhesion de la pintura y la calcomania. Adaptar las piezas bien juntas antes de encolar. Solamente utilizar pegamento plastico Revell. Utilizar el pegamento cuidadosamente y sin exceso. Raspar el cromado y la pintura en la zona que ha de ser encolada: Pintar las piezas pequeñas giratorias antes de sacarlas. Dejar que la pintura se seque totalmente antes de continuar el montaje. Cortar cada calcomania una por una y sumergirla en agua caliente durante aproximadamente 20 segundos. Deslizar la calcomania del papel en la posición marcada y golpearla suavemente con el papel secante.



Kleben
Glue
A coller
Lijmen
Limmas
Incollare
Engomar



Nicht kleben.
Don't glue.
À ne pas coller.
Niet lijmen.
Timmas ej.
Non incollare.
No engomar.



Anzahl der Arbeitsgänge.
Number of working steps.
Nombre d'étapes de travail
Het aantal der bouwhandelingen.
Antal arbetsmoment.
Numero di passaggi.
Numero de operaciones de trabajo.



Wahlweise
Optional
Facultatit
Ter keuze
Valfritt
Facultativo
Opcional

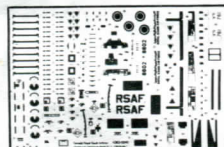

Abziehbild in Wasser einweichen und anbringen.
Soak and apply decals.
Mouiller et appliquer les décalés.
Transfer in water even laten waken en opbrengen.
Blöt och fäst dekalerna.
Immergere in acqua ed applicare decal.
Remojar y aplicar las calcomanías.



Abbildung zusammengebauter Teile.
Shown assembled.
Vu assemble.
Afbeelding van een gebouwde onderdeel.
Visas hopsatt.
Figura assemblata.
Presentado montado.



Klarsichtteile
Clear parts
Pièces transparentes
Transparente onderdelen
Genomskijnige detailjer
Parte trasparente
Limpiar las piezas

Nicht benötigte Bauteile.
Parts not used.
Pièces non utilisées.
Niet benodigde onderdelen.
Delar som inte används.
Parti non usate.
Piezas no utilizadas.

64, 65, 75, 76, 77,
2x 79, 2x 81, 2x 82,
89, 90, 91

<p>A</p> <p>MATT FLESH MATT HAUTFARBE 35 COULEUR CHAIR MAT HUIDKLEUR MATT HUDFARGAD COLOR PELLE SMORTO</p>	<p>B</p> <p>ANTHRACITE ANTHRAZIT 9 ANTHRACITE ANTHRACIET ANTRACIT ANTRACITE</p>	<p>C</p> <p>FIERY RED FEUERROT 330 ROUGE VERMILLON VUURROOD ELDRÖD ROSSO ACCESSO</p>	<p>D</p> <p>LEAF GREEN LAUBGRÜN 364 VERT FEUILLE LOOF GROEN LÖVGRÖN VERDE-FOGLIA</p>	<p>E</p> <p>WHITE WEISS 301 BLANC WIT VIT BIANCO</p>	<p>F</p> <p>ALUMINIUM ALUMINIUM 99 ALUMINIUM ALUMINIUM ALUMINIUM ALUMINIUM</p>	<p>G</p> <p>GREENISH GREY GRÜNGRAU 87 GRIS VERT GROENGRUIS GRÄGRÖN GRIGIOVERDE</p>
<p>H</p> <p>METALLIC GREY EISENFARBIG 91 GRIS METALLIQUE IJZERKLEUR JÄRNGRÅ FERRO</p>	<p>I</p> <p>OCBRE OCKER 88 OCRE OKER OCKRA OCRA</p>	<p>30%</p> <p>MATT BRICK RED MATT ZIEGELROT 37 ROUGE FONCE MAT MAT DONKER ROOD MATT MÖRK RÖD ROSSO SCURO SMORTO</p>	<p>J</p> <p>70%</p> <p>MATT EARTH MATT ERDFARBE 87 COULEUR DE TERRE MAT MAT AARDKLEUR MAT JÖRGFARGAD COLOR TERRA SMORTO</p>	<p>K</p> <p>GREY GRAU 57 GRIS GRUIS GRÅ GRIGIO</p>	<p>L</p> <p>GRANIT GREY GRANITGRAU 89 GRIS GRANITE GRANITGRUIS GRANITGRÅ GRIGIO GRANITO</p>	

Dieser Bausatz wurde in mehrfachen Qualitäts- und Gewichtskontrollen auf Vollständigkeit überprüft. Reklamationen können nur bearbeitet werden, wenn die Bauanleitung und das aus der Kartonage ausgeschnittene EAN-Strichcode-Feld eingeschickt werden. Einzelteile aus unseren Bausätzen für Umbauten usw. liefern wir mit Rechnung per Nachnahme. Unsere Adresse: Revell AG, Abteilung X, Henschelstr. 20-30, 32257 Bünde.

This model kit underwent various quality and weight controls to assure its completeness. Queries can only be processed when the building instructions are sent to Revell together with the EAN-Code of the product which is to be cut out from the packaging. Individual components of our model kits for conversion purposes can be ordered C.O.D. Write to: Revell AG, Department X, Henschelstr. 20-30, D-32257 Bünde.

L'intégralité des pièces de ce modèle réduit a été vérifiée au cours de plusieurs contrôles de qualité et de poids. Des réclamations ne peuvent être prises en considération que si le guide de montage ainsi que le code à barres EAN découpé du cartonnage nous soient envoyés. Des pièces détachées de nos modèles réduits pour transformations, etc. sont livrées suivant facture contre remboursement. Notre adresse: Revell AG, département X, Henschelstr. 20-30, D-32257 Bünde.

Deze bouwdoos is bij meerdere kwaliteits- en gewichtskontroles op volledigheid gecontroleerd. Klachten kunnen alleen dan in behandeling worden genomen, wanneer de bouwaanwijzing en het uit de kartonnen doos uitgeknipte veld met de EAN barcode worden opgestuurd. Losse onderdelen uit onze bouwdoos voor ombouw en dergelijke leveren wij met factuur onder rembours. Ons adres: Revell AG, Afdeling X, Henschelstr. 20-30, D-32257 Bünde.

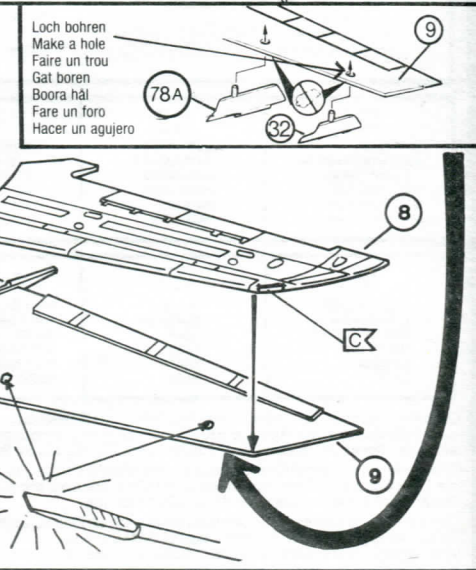
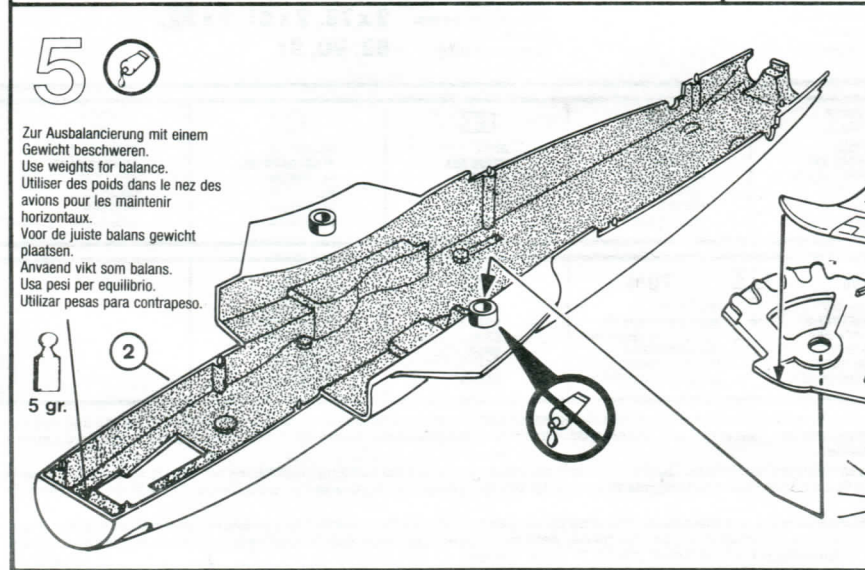
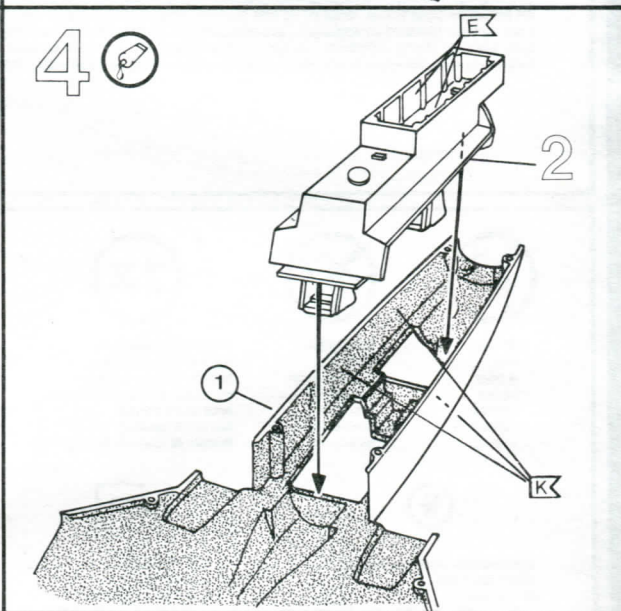
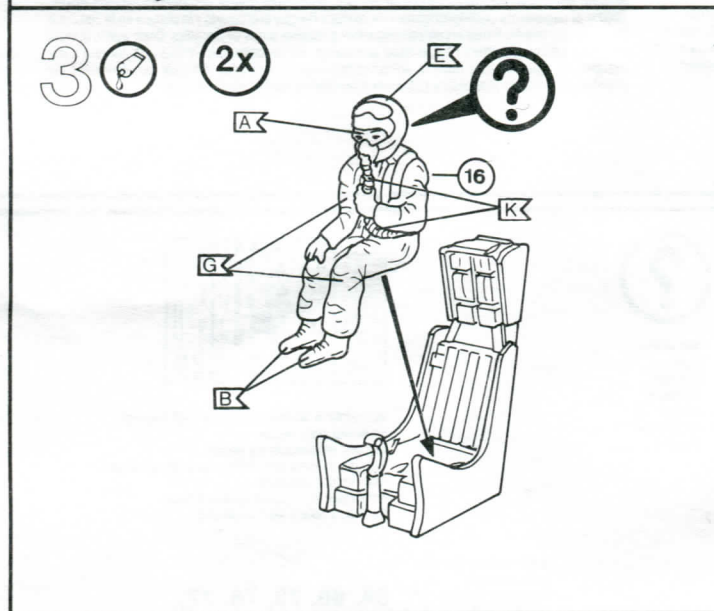
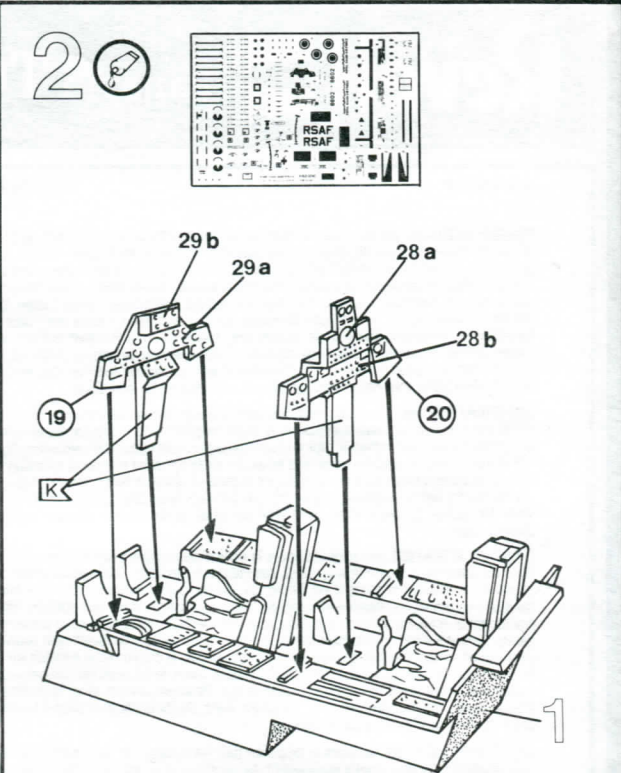
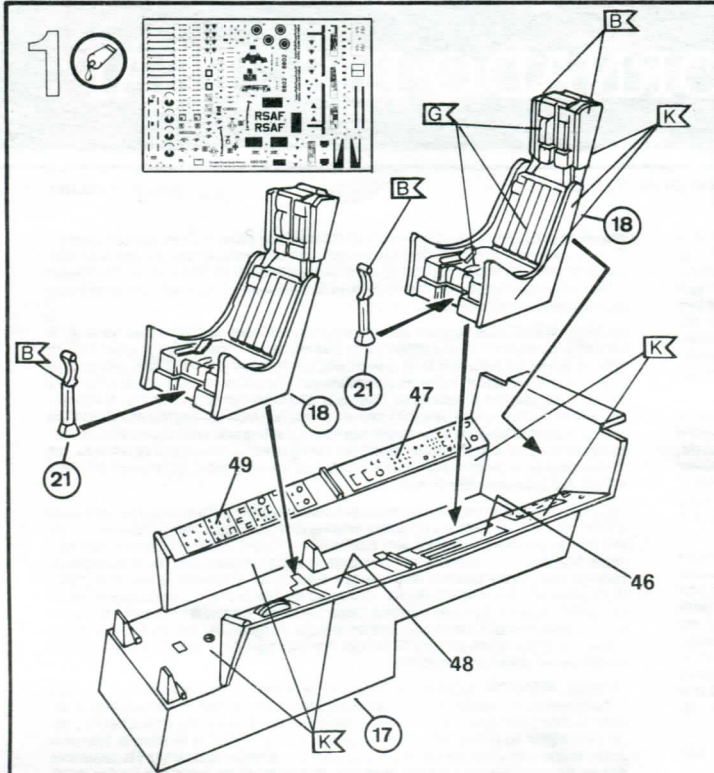

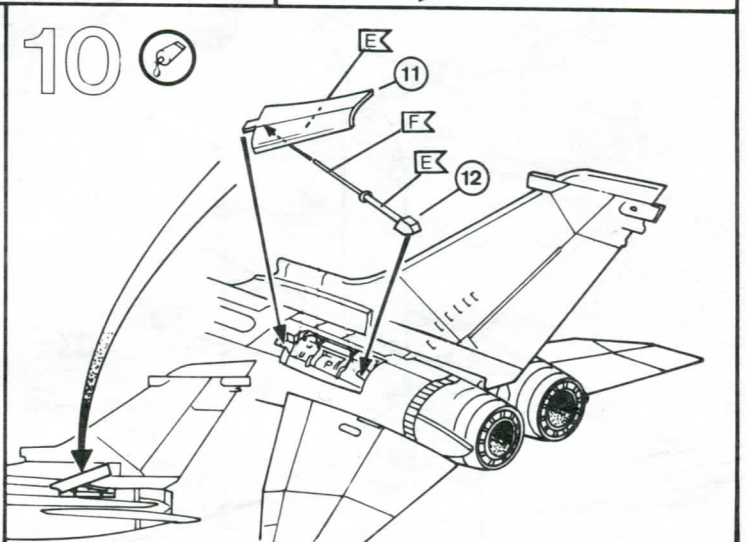
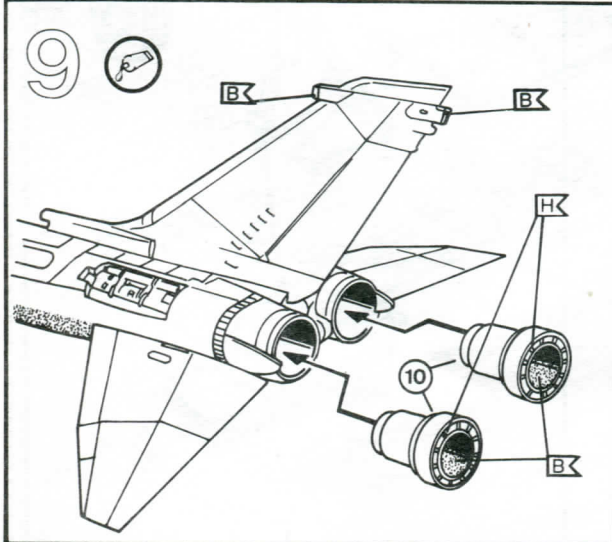
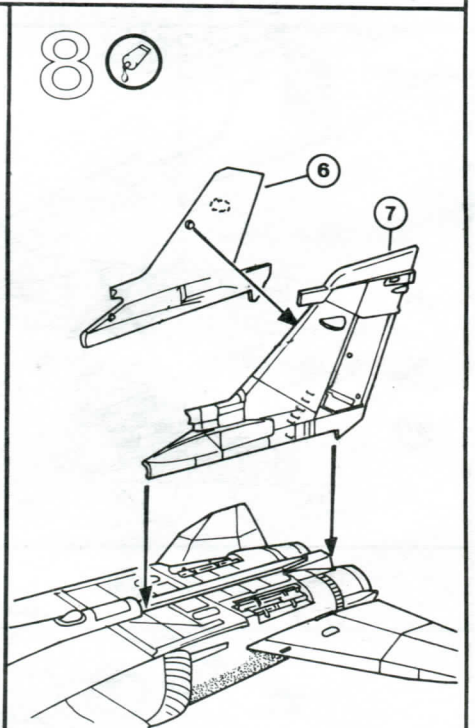
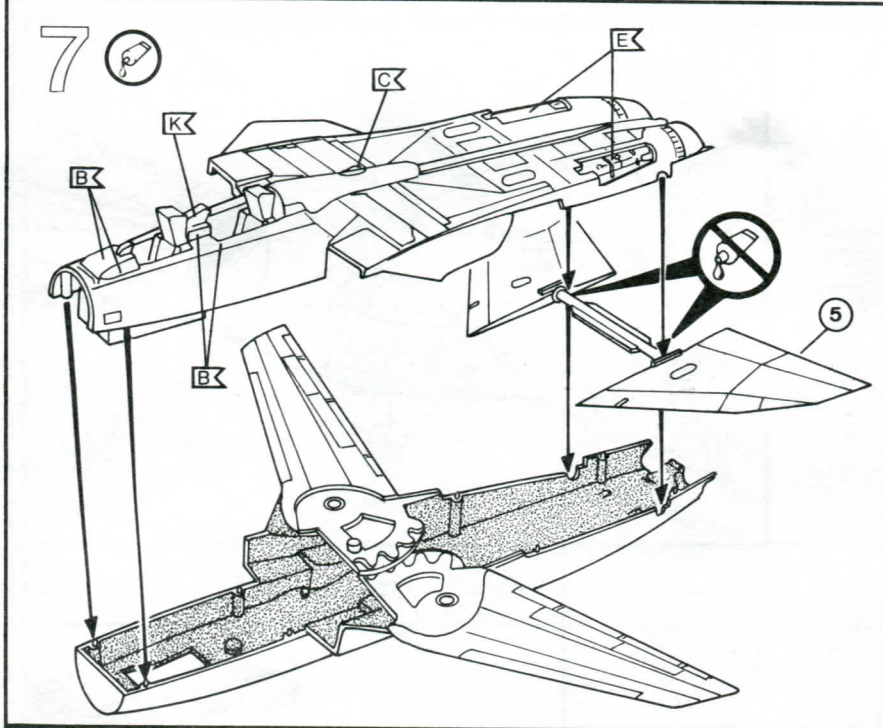
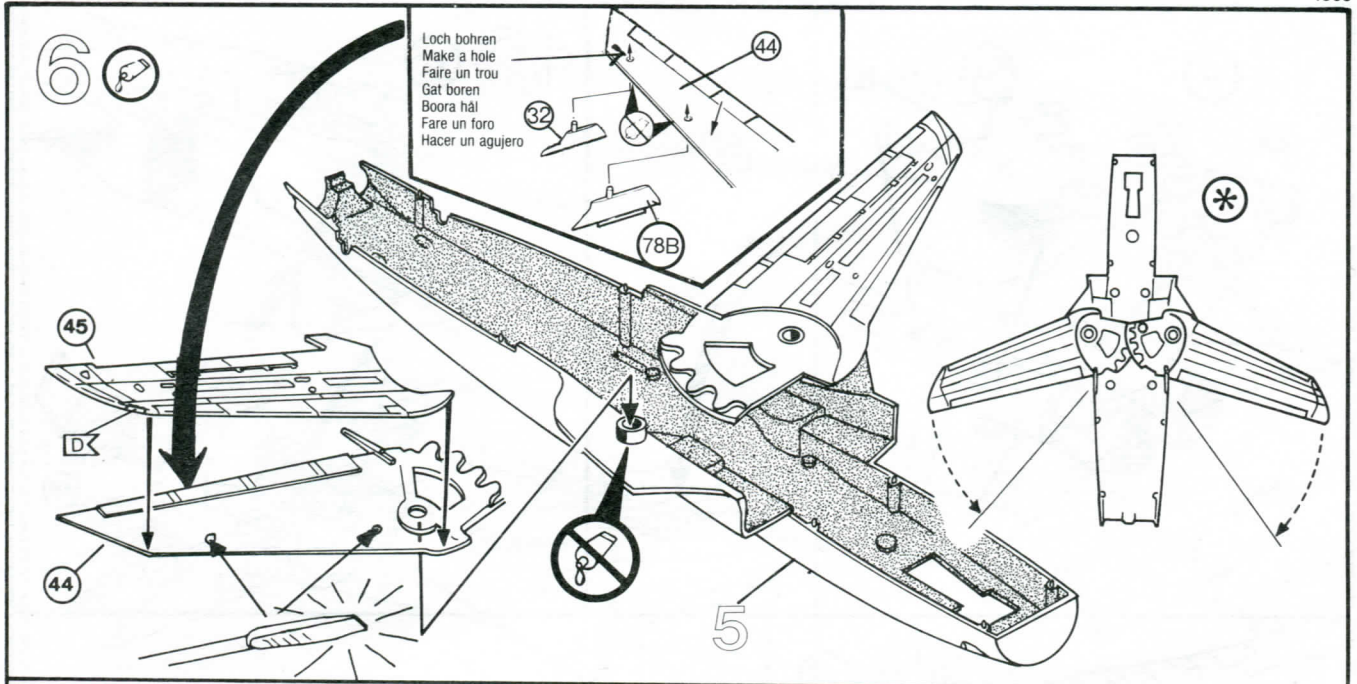

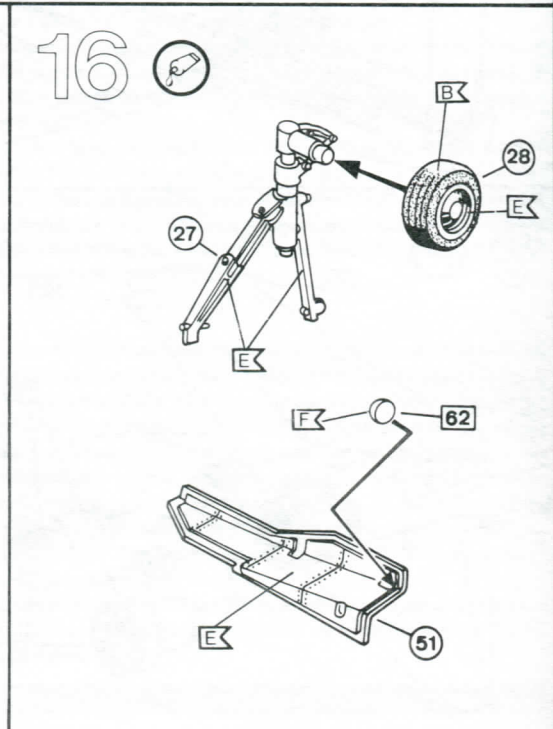
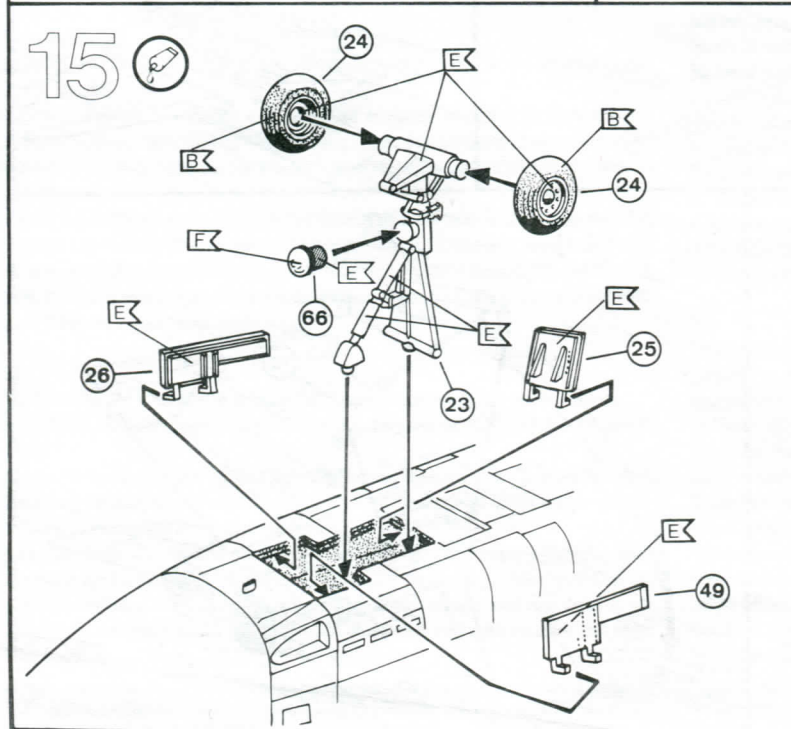
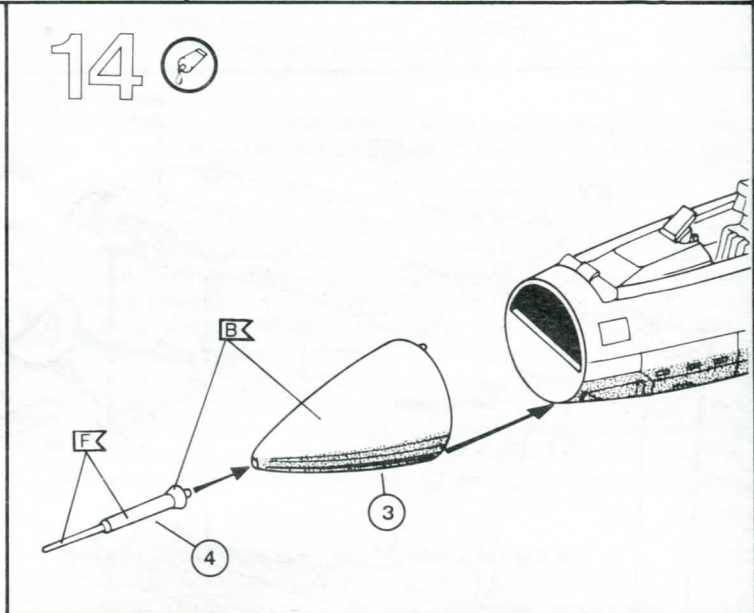
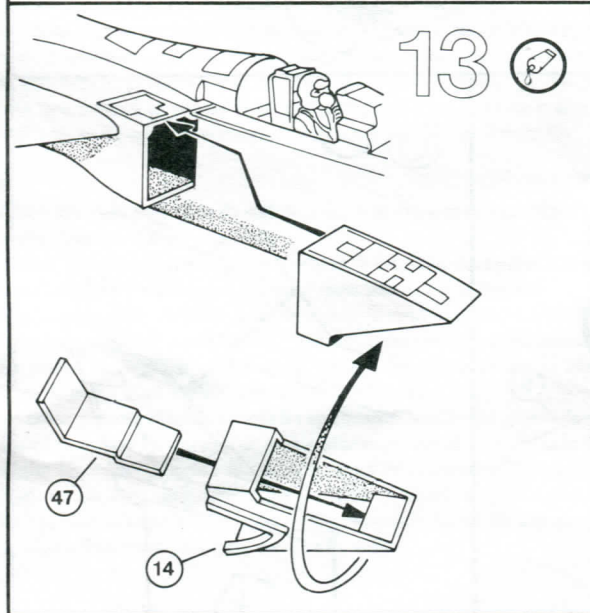
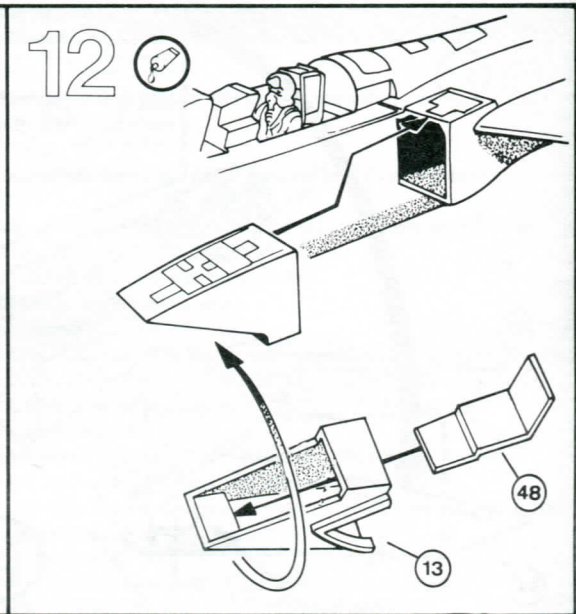
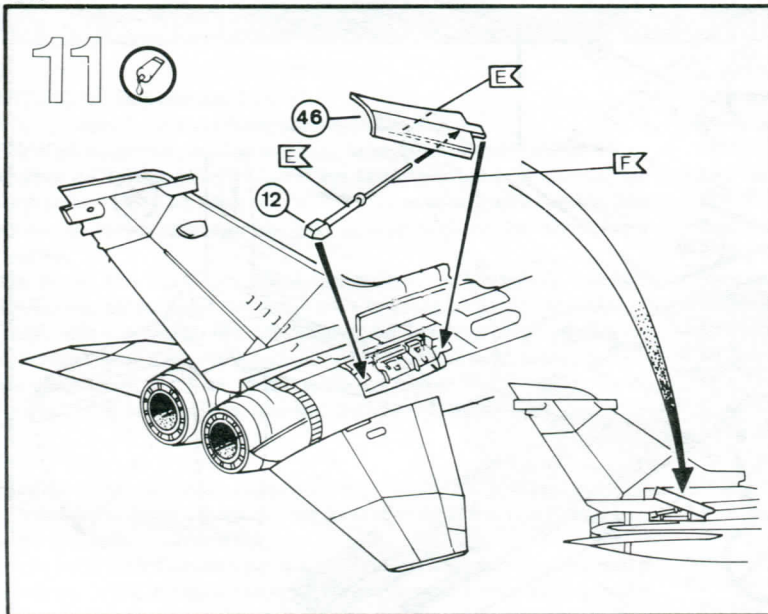

17 

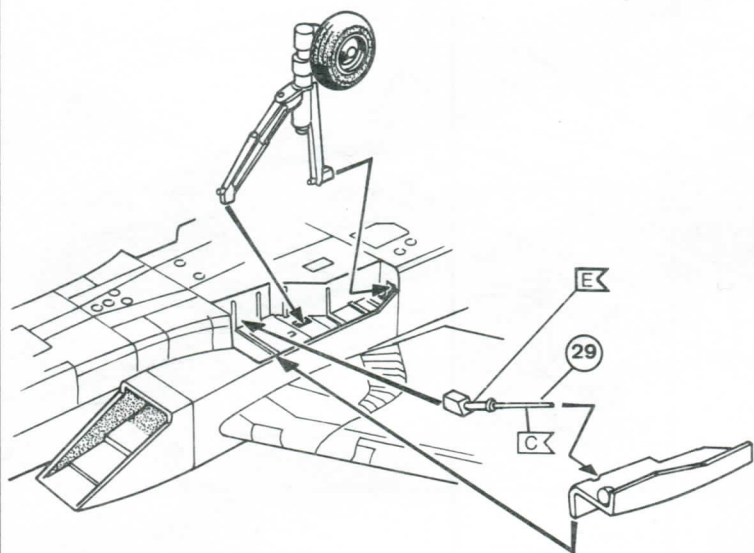

18 

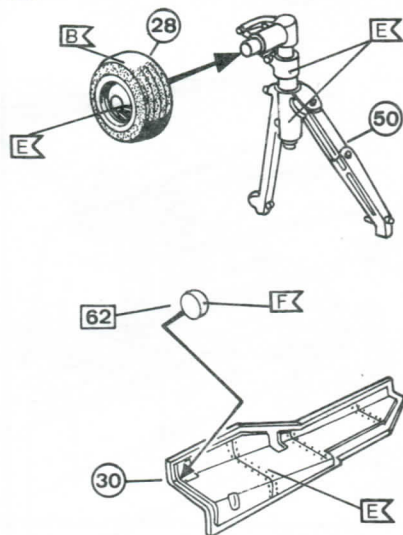

19 

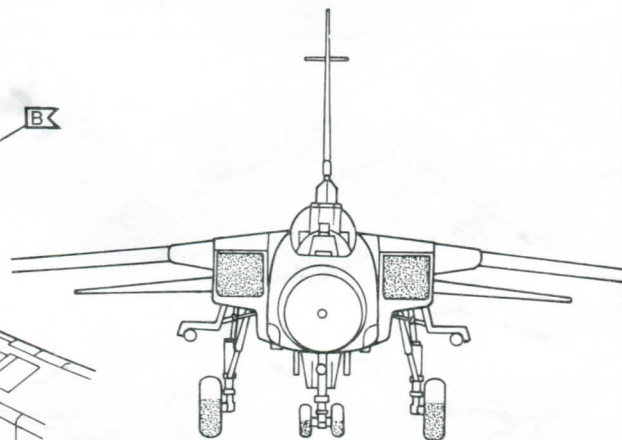
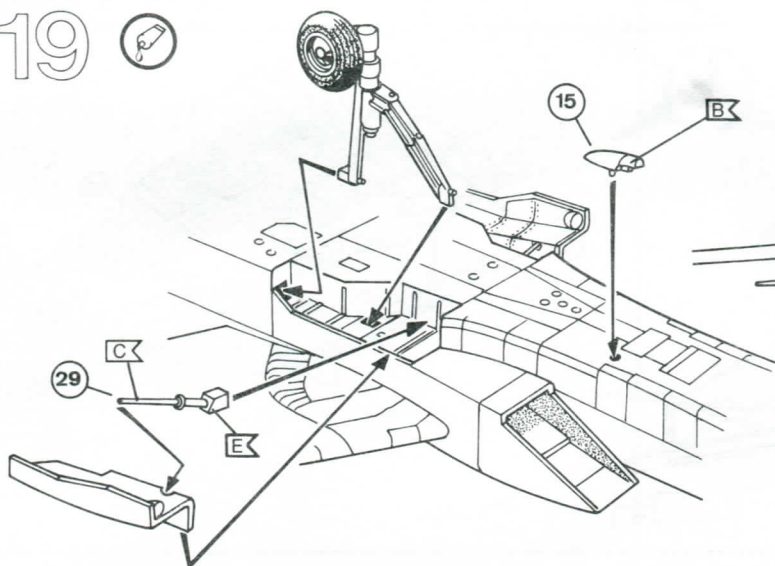

20 

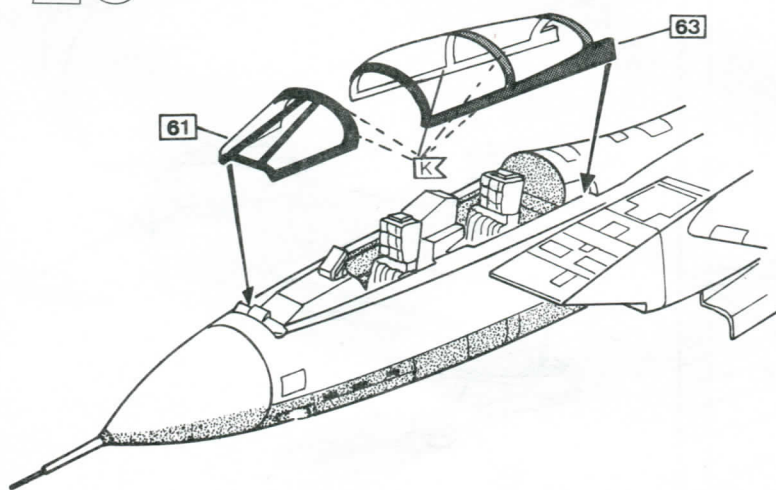

21 

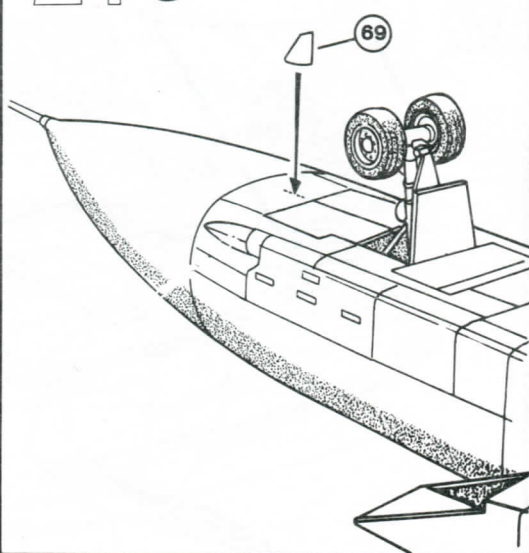

22 

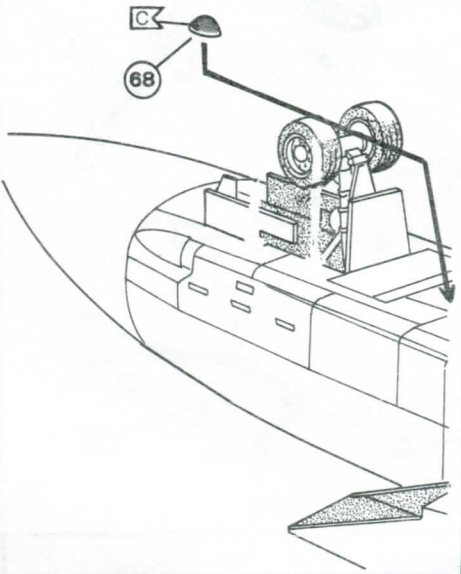

23 

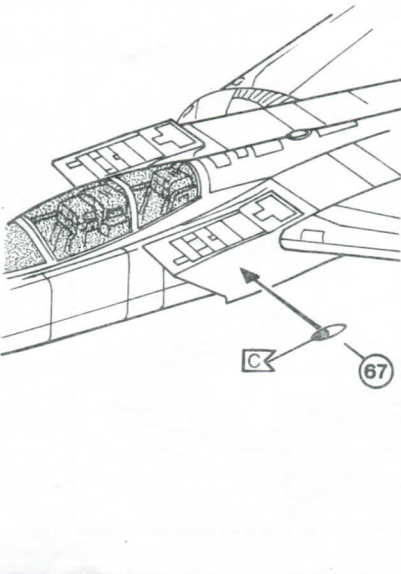

24 

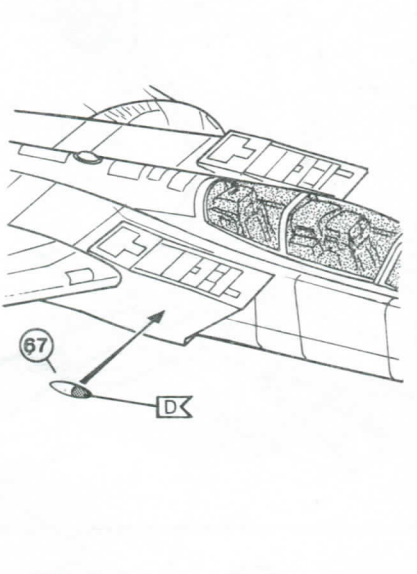

25 

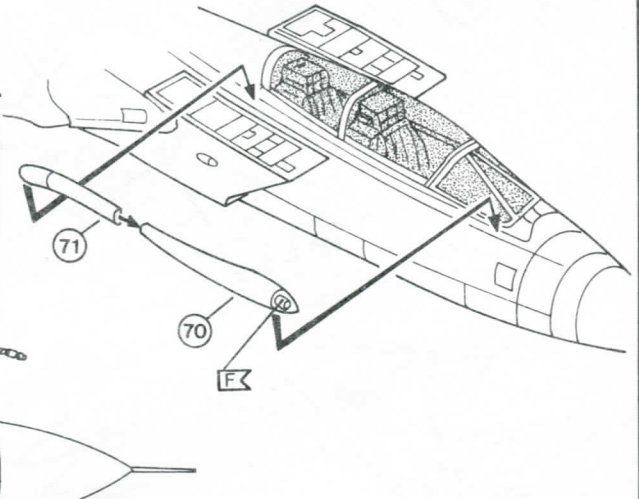
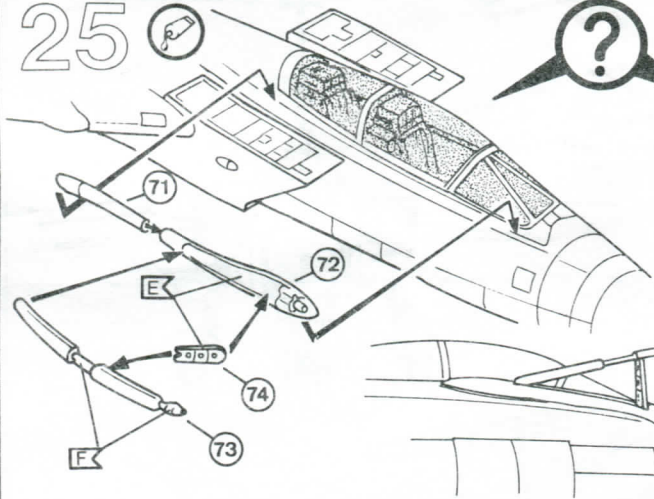

26 

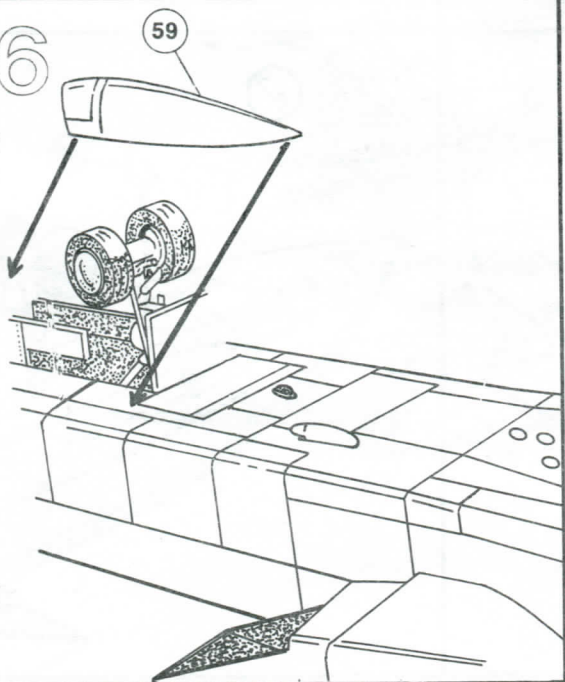

27 

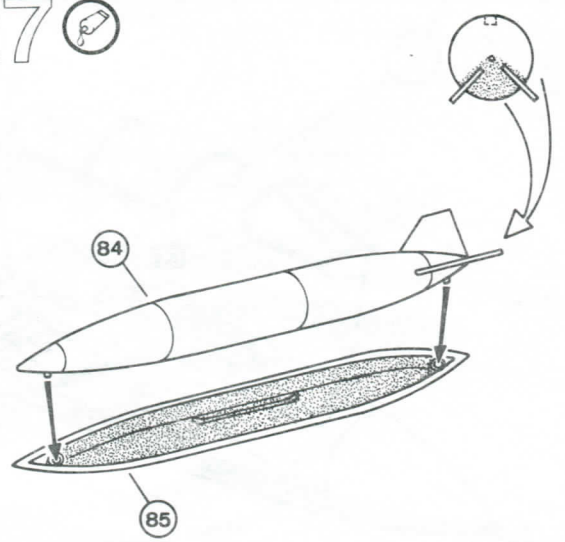

28

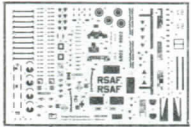
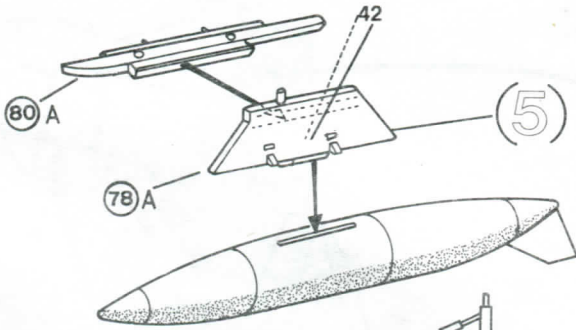

29

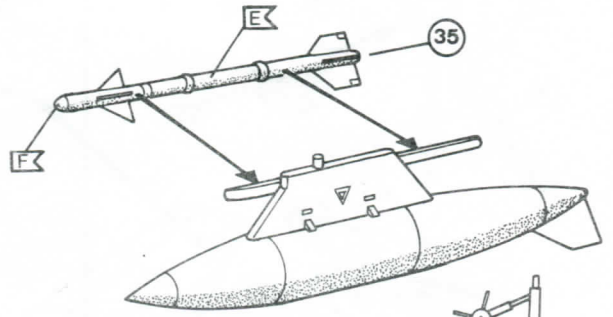

30

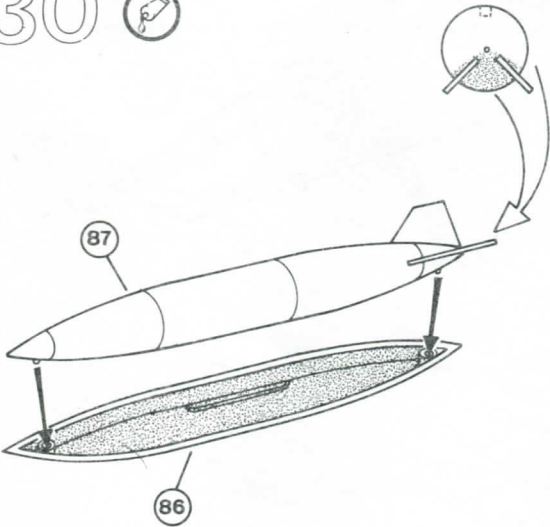

31

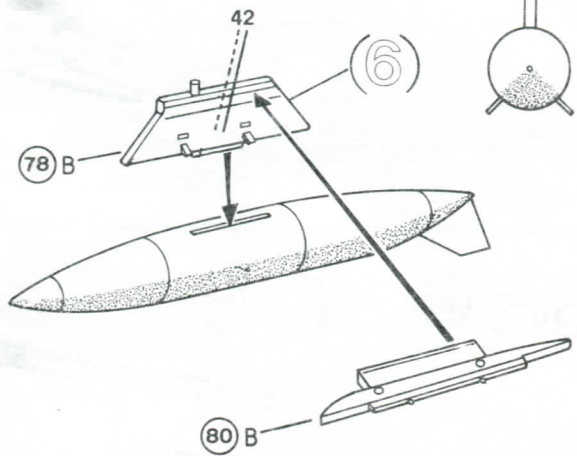
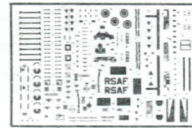

32

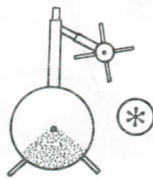
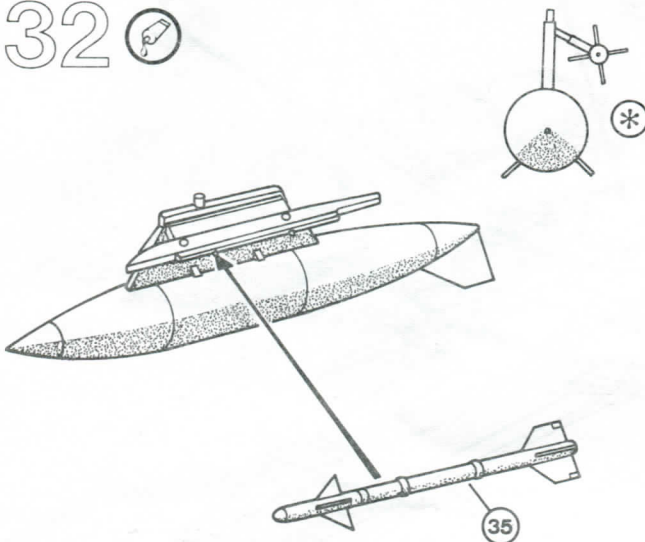

33

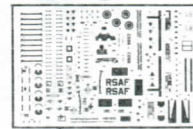

2x

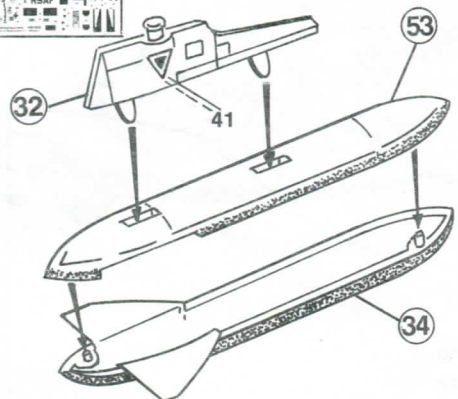

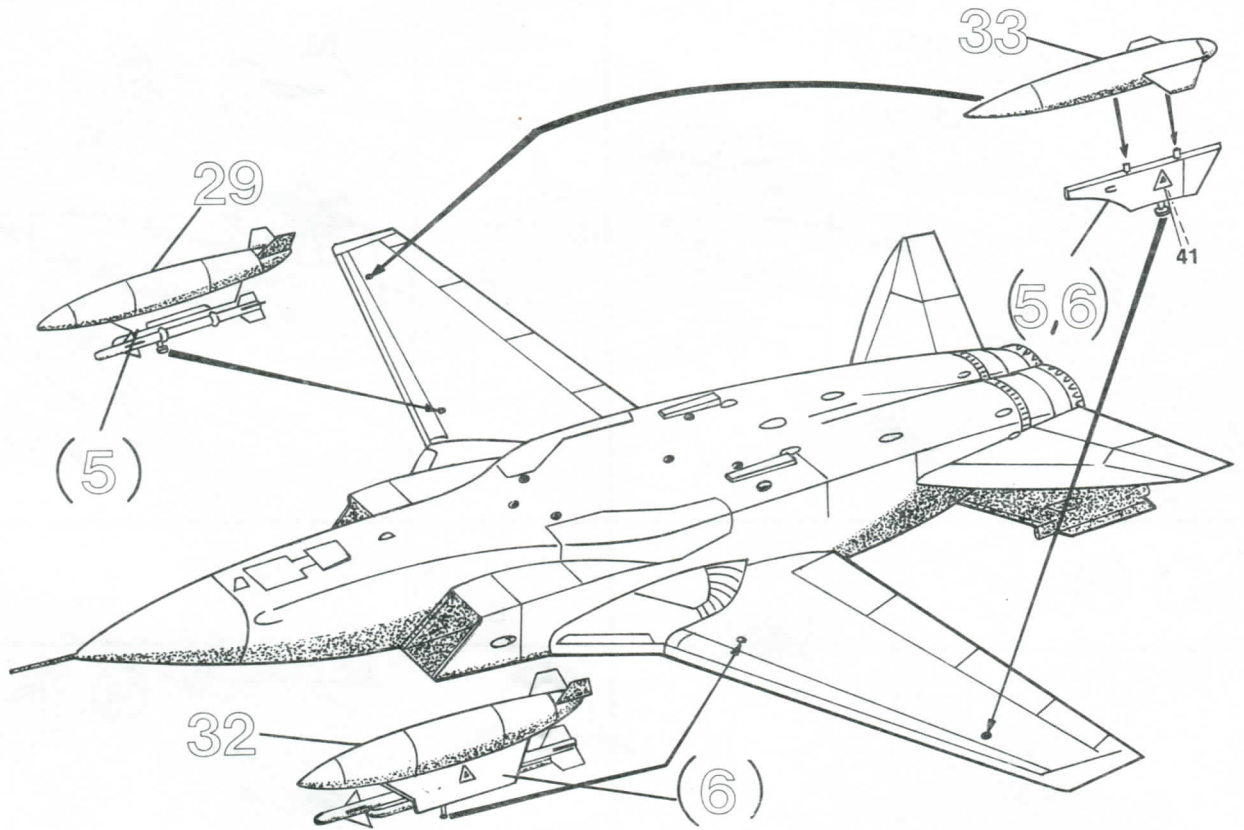
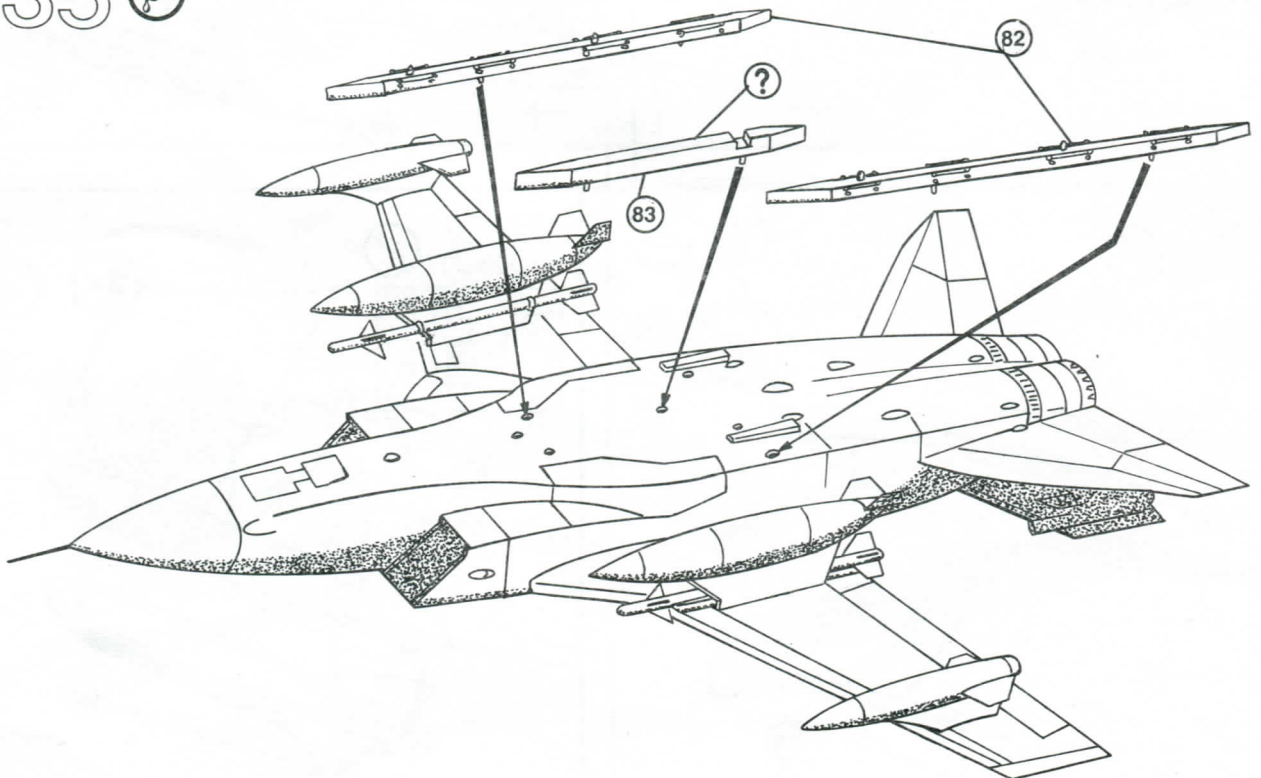
34 35 

36

