



Hawk T MK.1A

ホーク T.1A

英国“鹰”T MK.1A教练机

PLEASE READ BEFORE OPERATION!

- * Tools recommended as below: (Not included)
Adhesives; Paints; Side Cutters; Sharp Edged Pliers; Modeling Knife; Modeling File; Nippers; Drill; Scissors; Sand Paper; Soft Cloth; Cyanoacrylate Glue.
- * Make sure to read this instruction listed below before assembling.
- * The kit contains the small parts, they can be dangerous if swallowed by mistake, so keep them away from reach of children.
- * Cut the all parts off carefully and remove the waste parts into the garbage can.
- * More caution and care should be needed for cutting and handling the photo etched parts.
- * Make attention that some parts should be attached the decal when assembled.
- * During assembling, please tear up and throw away the plastic bags, or may cause the dangerous if wearing over head by children's mistake.
- * When using the adhesives and paints, please do not use them in the closed room or near the fire, also must be very careful to protect your eyes, face and clothes.
- * Adult supervised when assembled by children under 14 years old.

装配前请仔细阅读:

- * 推荐使用的模型工具(请自备):
专用模型胶水, 专用模型油漆, 水口剪刀, 长咀钳, 刀片, 锉刀, 镊子钳, 钻, 剪刀, 软布, 砂纸, 瞬间快干胶等。
- * 用水口剪刀或刀片小心切下所有塑胶零件和蚀刻片零件, 不要遗失小零件。
- * 切取蚀刻片时应特别注意防止利边划伤手指。
- * 用模型锉刀小心锉平所有零件表面的注射浇口。
- * 用适量的强力快干胶水粘合蚀刻片零件和金属轴, 切忌过量, 否则可能导致可动零件被粘住。
- * 注意某些零件表面需在装配时同步贴水上贴纸。
- * 制作时应远离幼儿并将包装袋及时收妥, 谨防小孩玩耍而引起意外。



cyanoacrylate glue
强力胶



weight
配重



make hole
钻孔



cut / remove
切除



option
选择



no cement
不涂胶水



decal
贴纸



bend
弯曲



repair
填补

The method to apply the decals

1. Cut off the decal from the decal paper and put it into the warm water 40°C for 10 seconds.
2. Take the decal from the water and put it on a piece of clean cloth.
3. Remove the decal slowly from the paper to the targeted location by a wet finger.
4. Use a piece of dry and soft cloth to press it gently on the decal until it getting dry and no bubble existing.

水贴纸的使用方法:

- 一. 把相关的印花从水贴上剪下, 放入40°C左右的温水中浸10秒。
- 二. 然后将印花放在干净的布上。
- 三. 拿上印花纸板, 手指蘸水将印花移到适当的位置。
- 四. 用软干布轻压印花直至水干, 气泡消失。

部品图
Parts

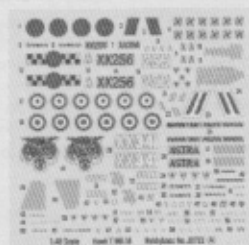
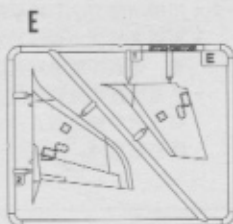
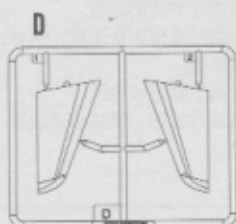
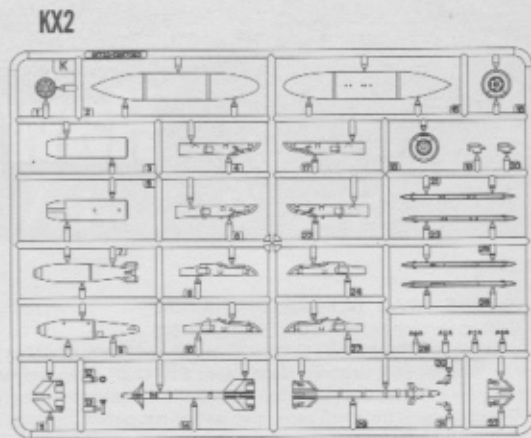
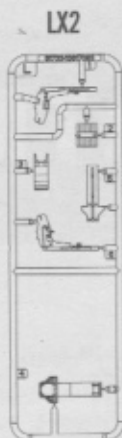
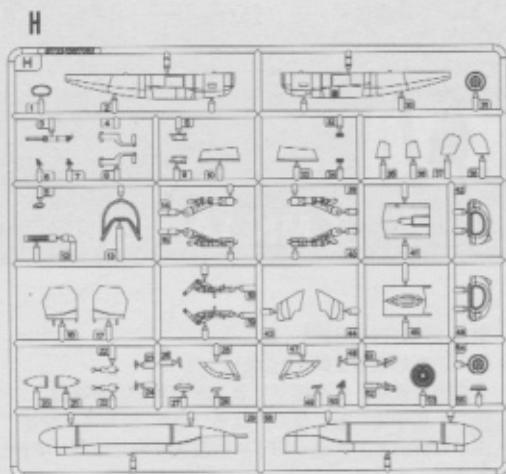
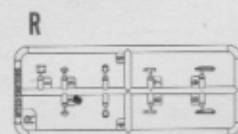
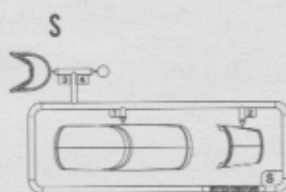
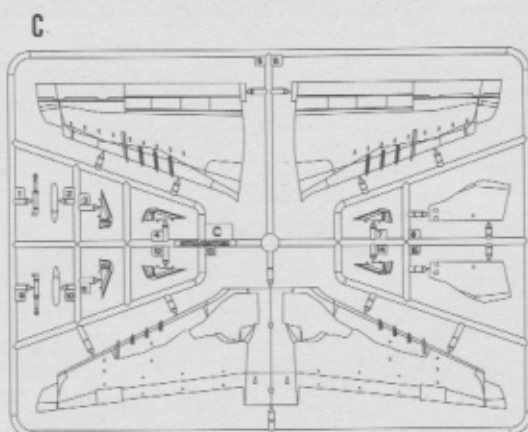
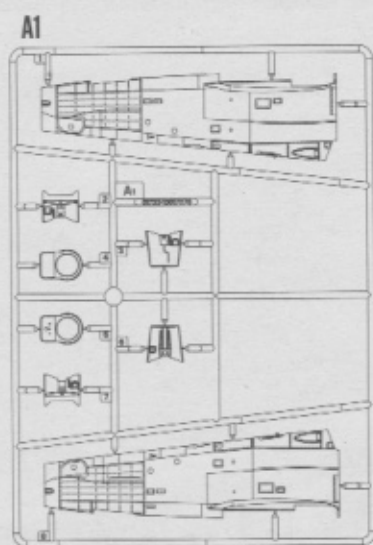
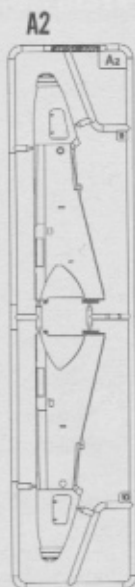

《水贴》A
Decal A

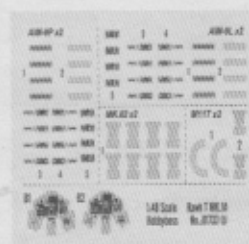

《水贴》B
Decal B

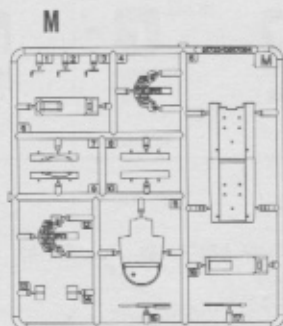

Unused parts

《蚀刻片》X2
Photo etched part (PE)



不用的部件: A4 A6 A7 H5 H9 H13 H26
Unused parts H29 H47 H56 M7 M9 M14
M15 M16 R1

1
STEP

《座舱》
Cockpit

H 12 33

消光黑
Flat black

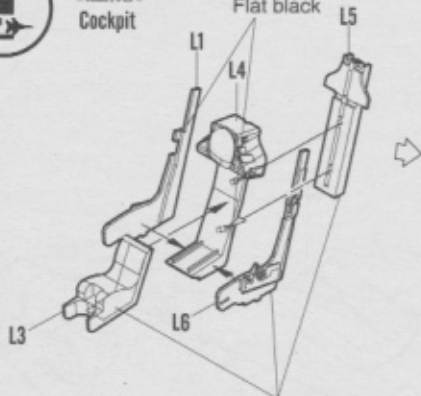

H 12 33

消光黑
Flat black



贴纸
Decal
B1



贴纸
Decal
B2

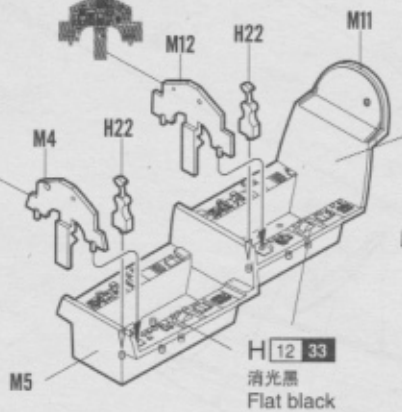

H 12 33

消光黑
Flat black

H 317 317

灰色
Dark gull grey

制作2组
Make two

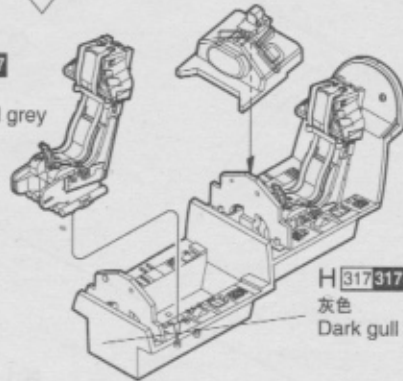

H 317 317

灰色
Dark gull grey

H 12 33

消光黑
Flat black

2
STEP

H 317 317

灰色
Dark gull grey

《座舱》
Cockpit

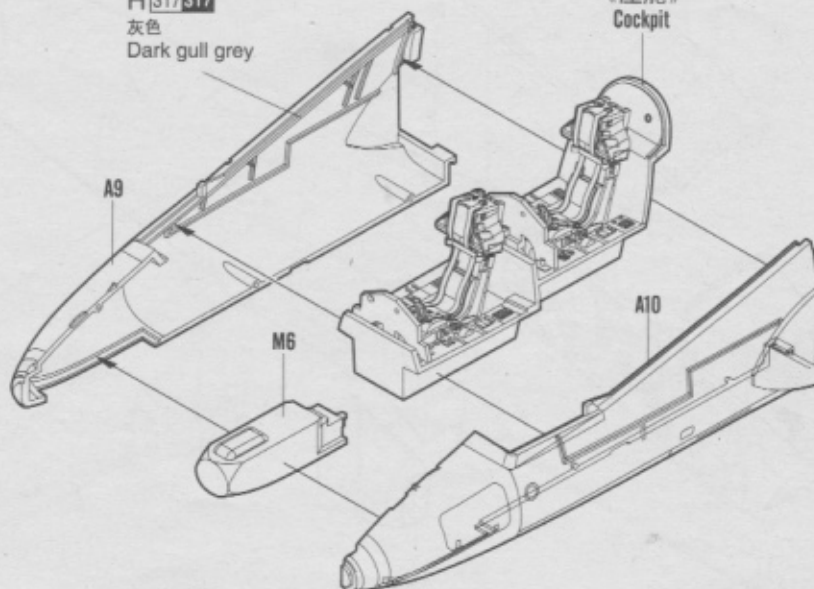

3
STEP

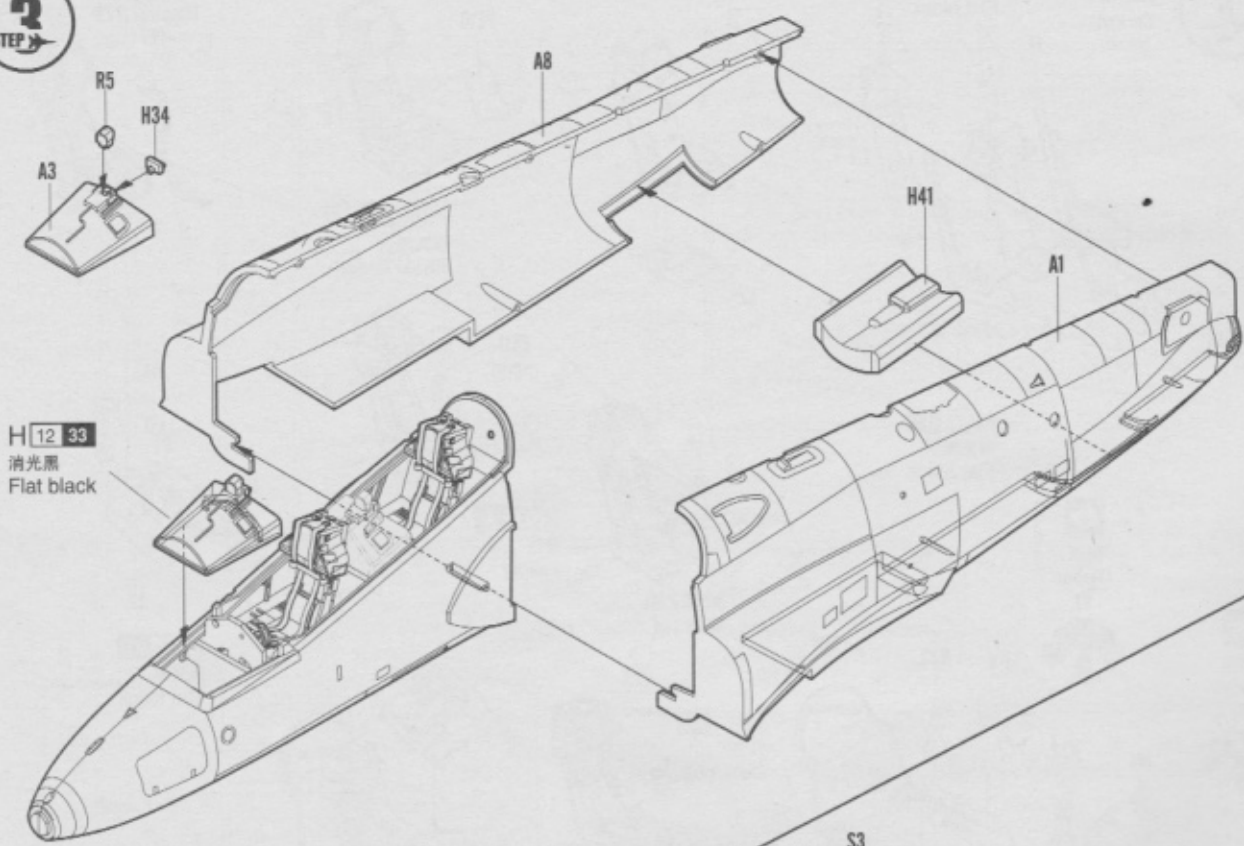

4
STEP

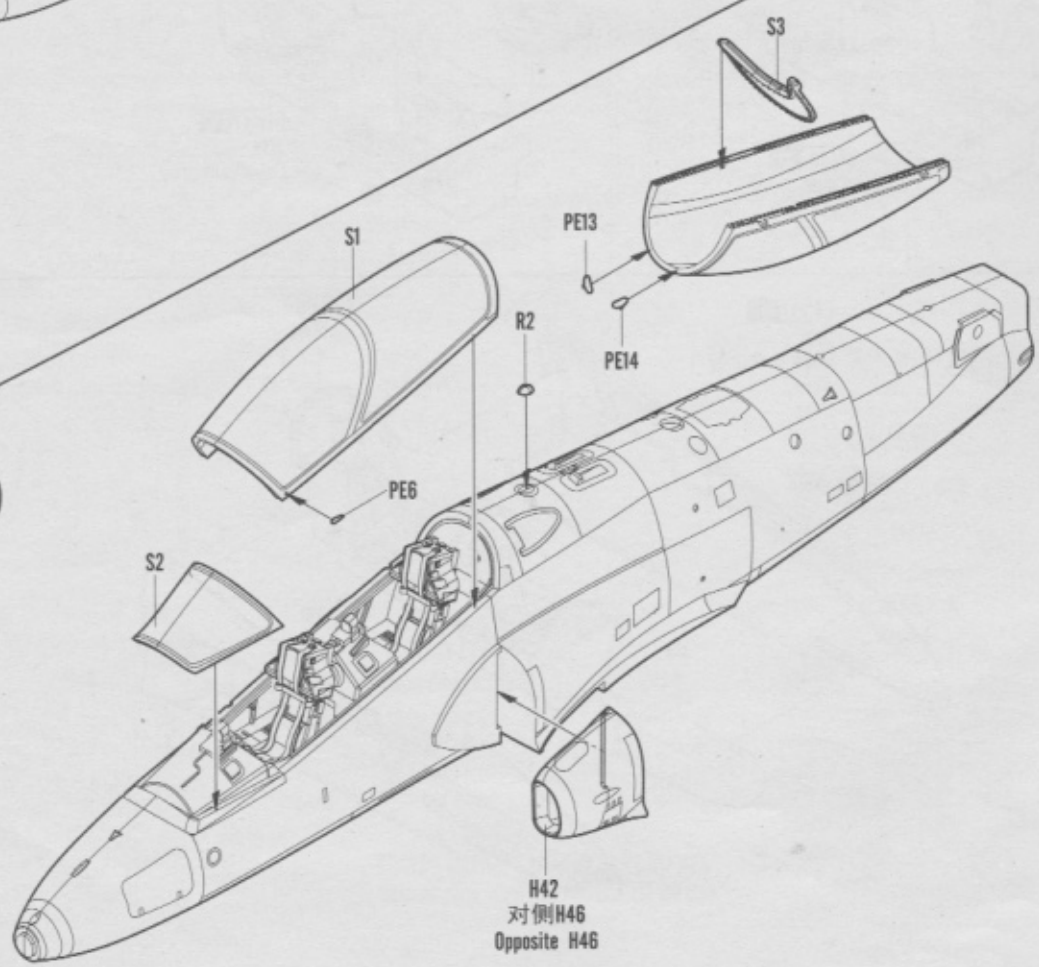

5
STEP

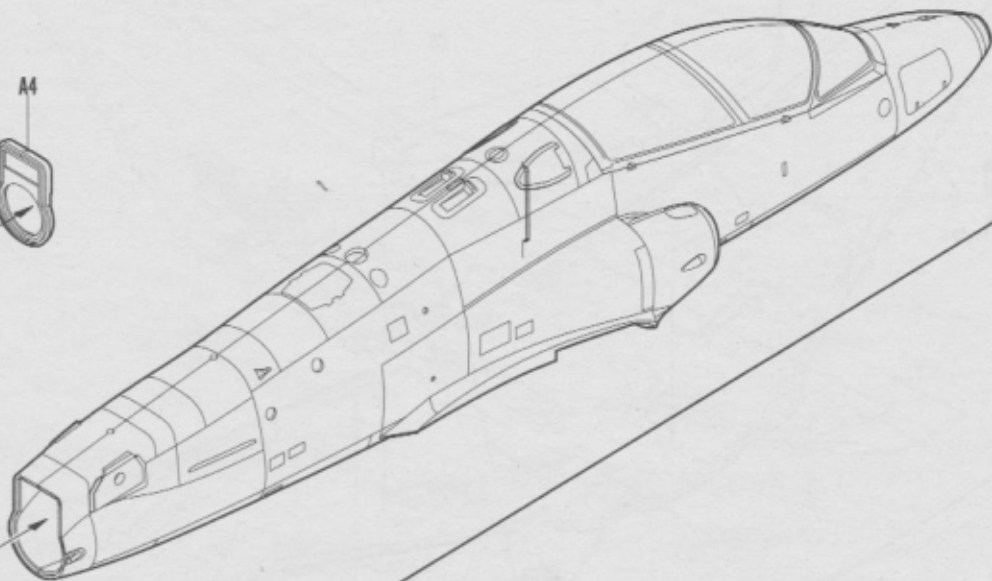
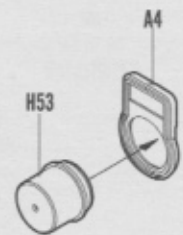

6
STEP

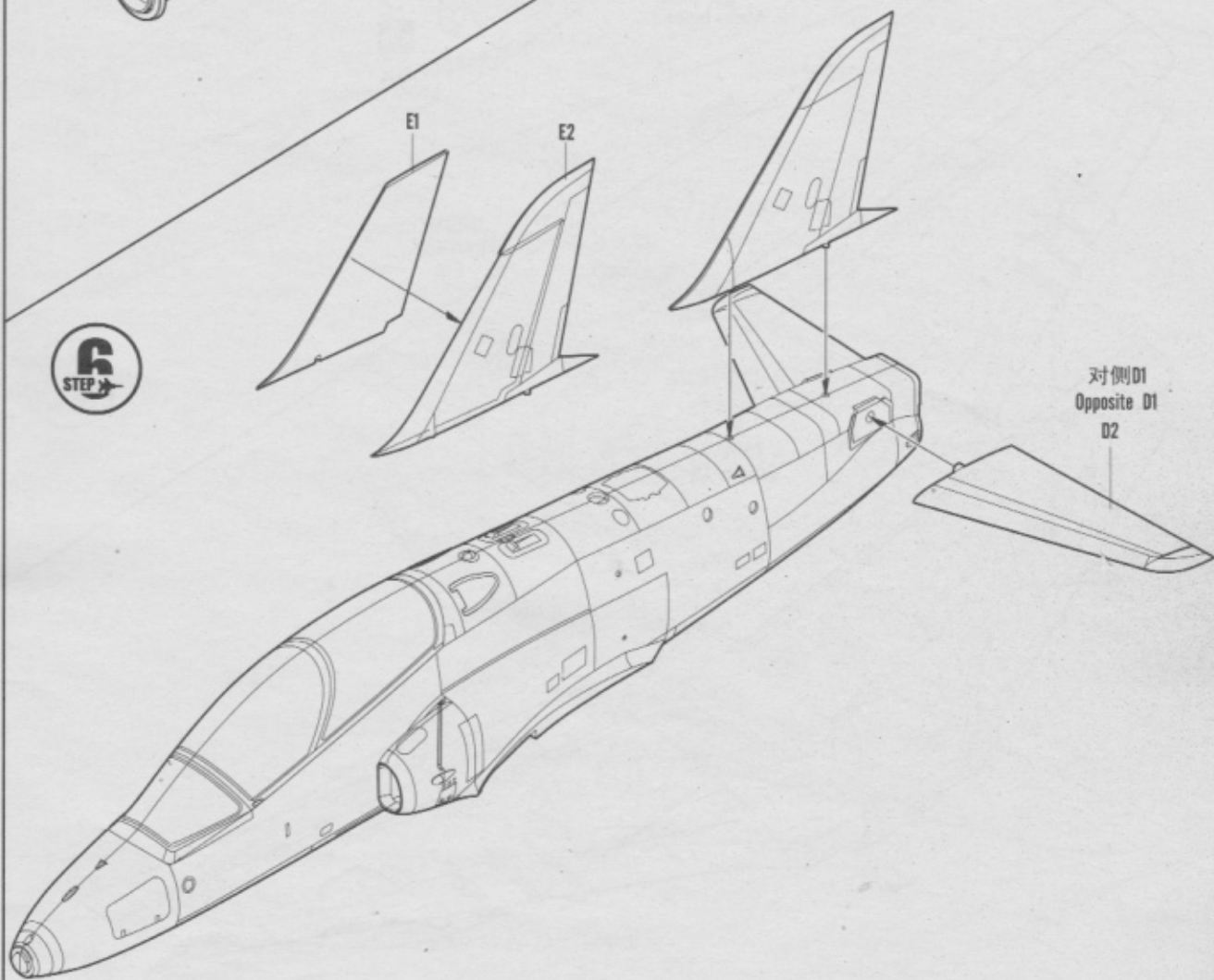
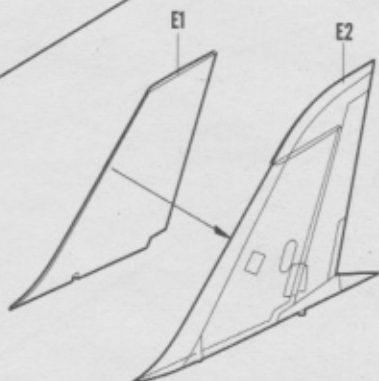

对侧D1
Opposite D1
D2

7
STEP →

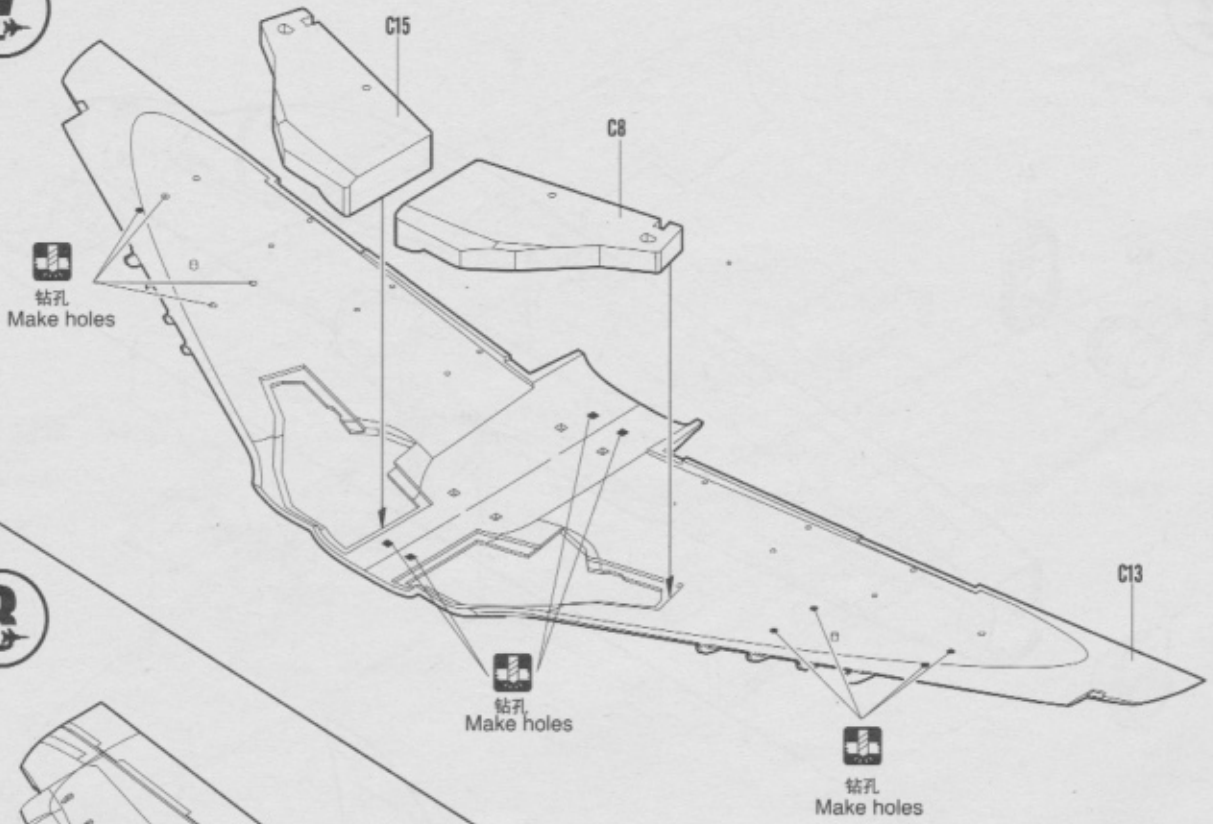

8
STEP →

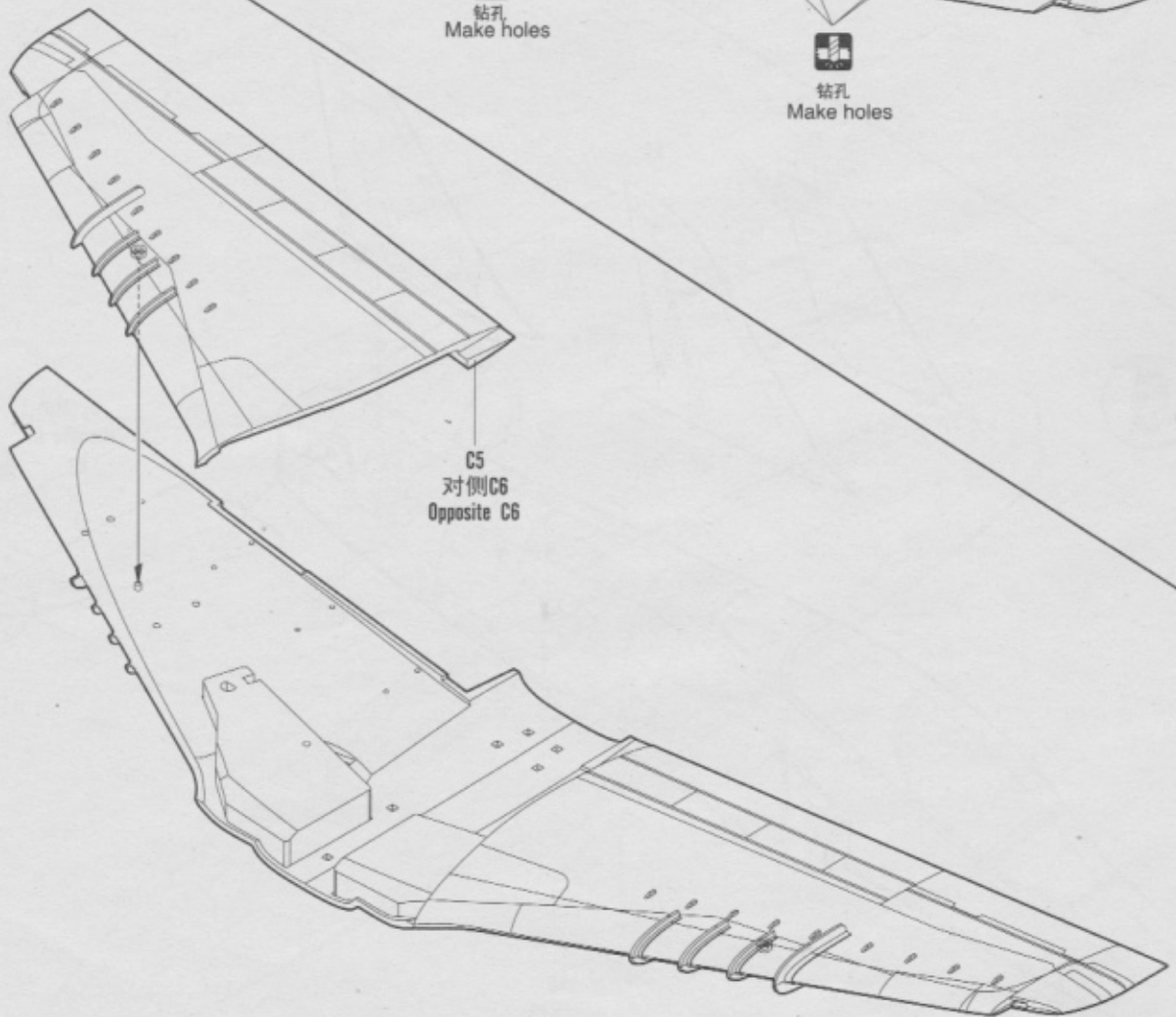

9
STEP →

R8
对侧R9
Opposite R9

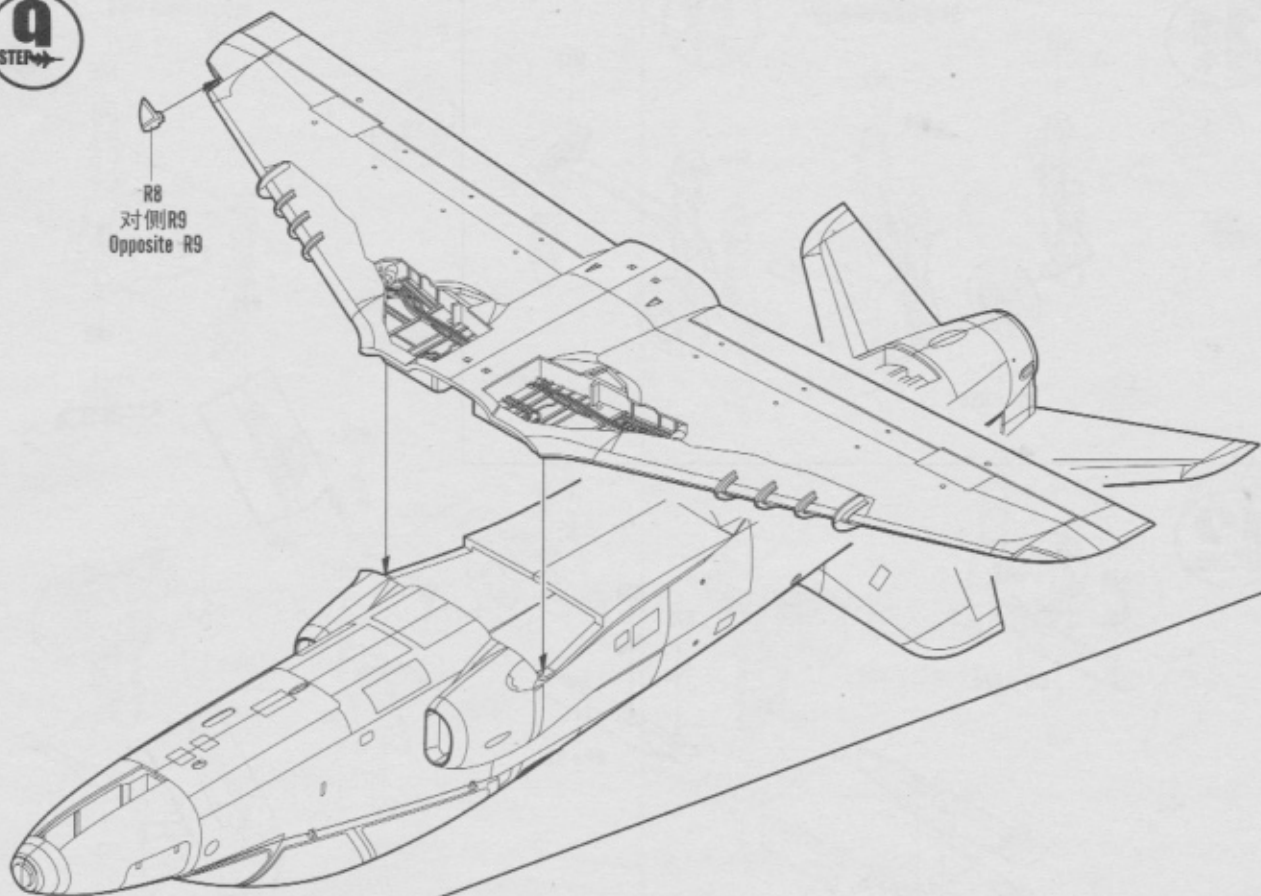

对侧C2
Opposite C2
C10

C11 对侧C3
Opposite C3

C4 对侧C12
Opposite C12

C14 对侧C7
Opposite C7

R3

10
STEP →

S4

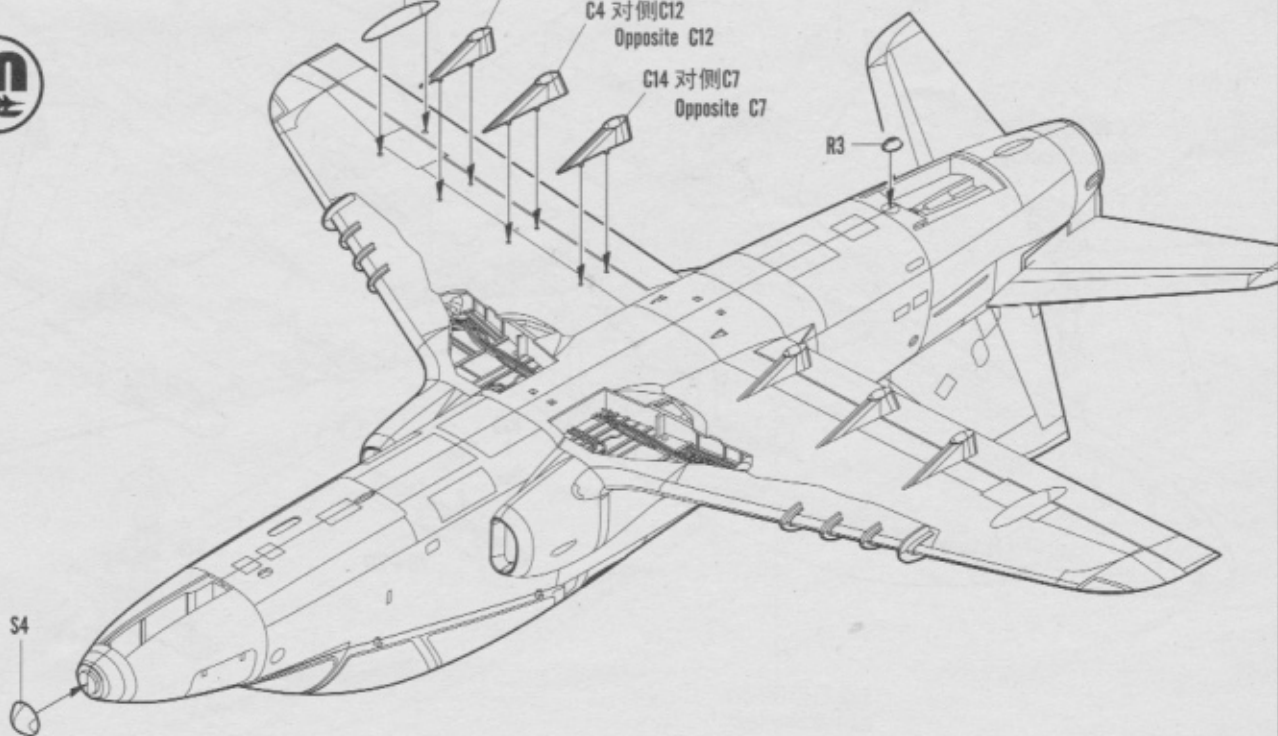

11
STEP

《前起落架》
Nose undercarriage

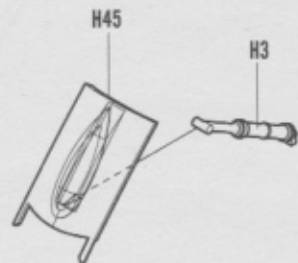
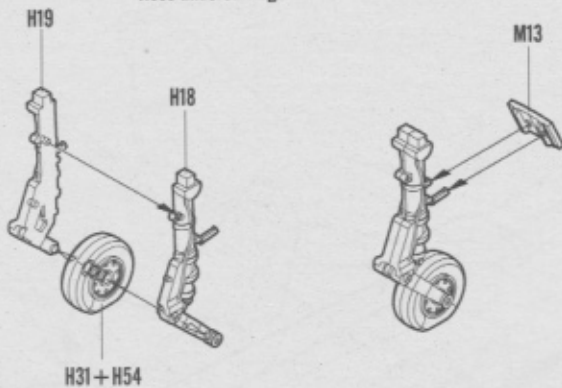

12
STEP

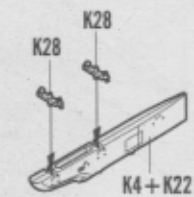
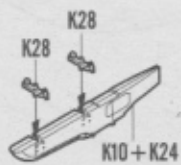

《前起落架》
Nose undercarriage

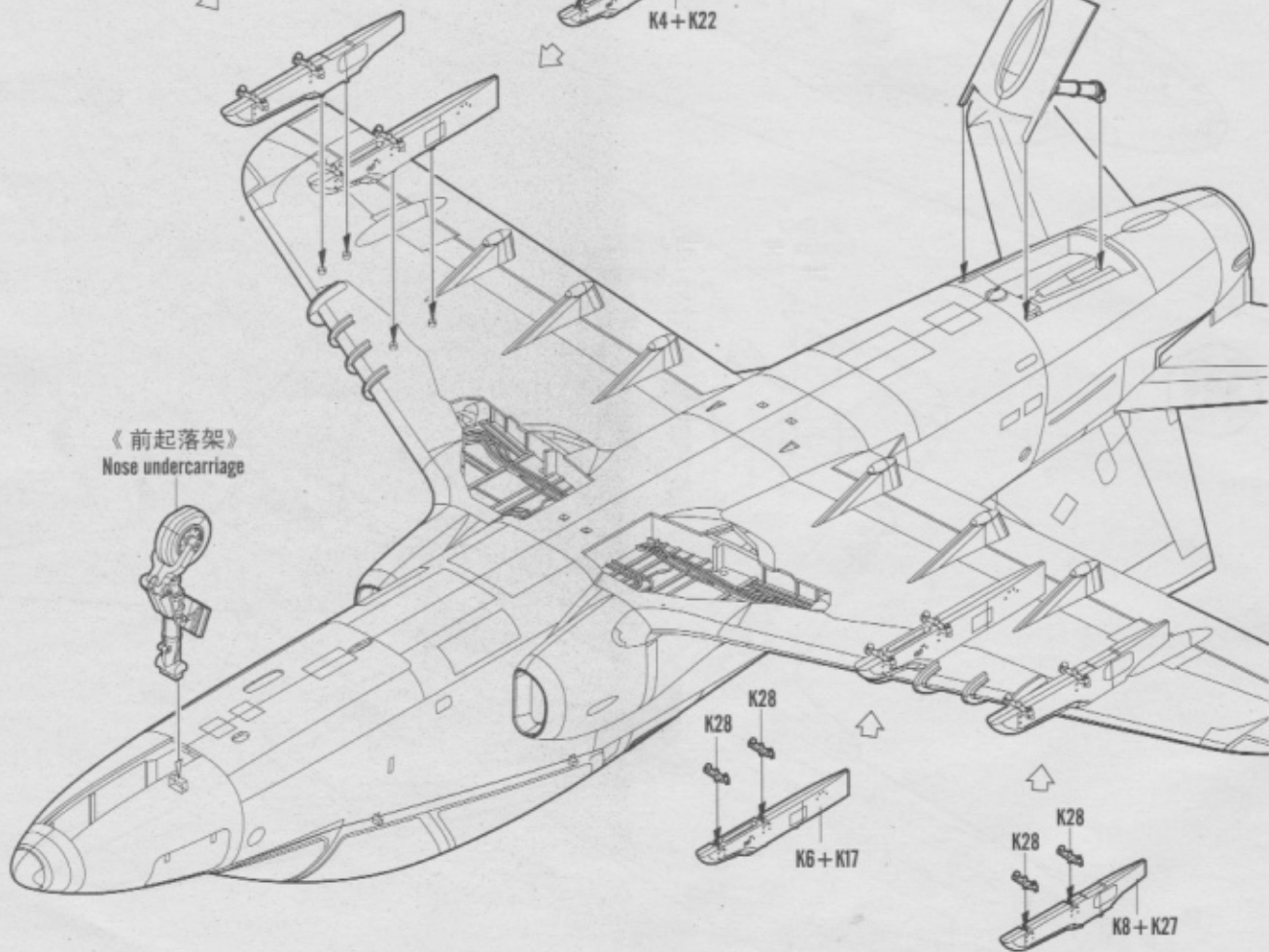

12
STEP

《右侧起落架》
Right undercarriage

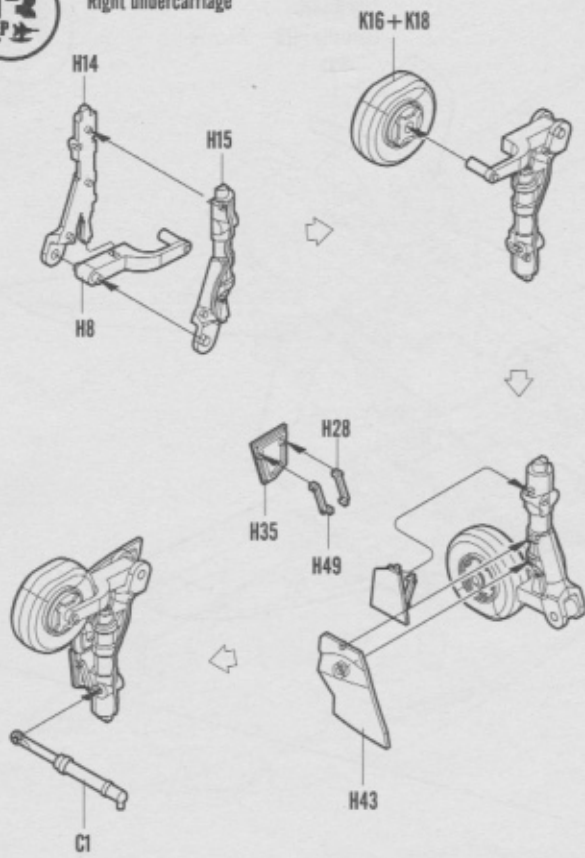

11
STEP

《左侧起落架》
Left undercarriage

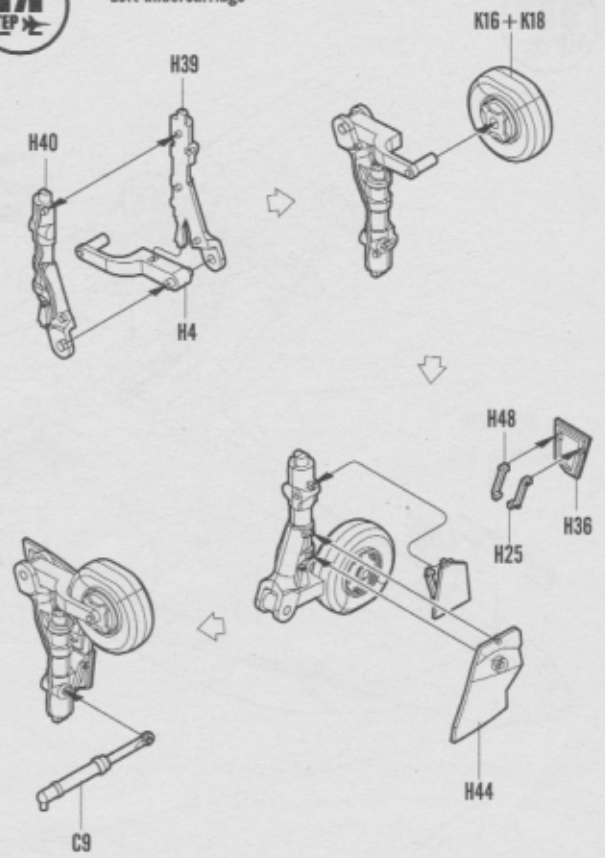

15
STEP

《左侧起落架》
Left undercarriage

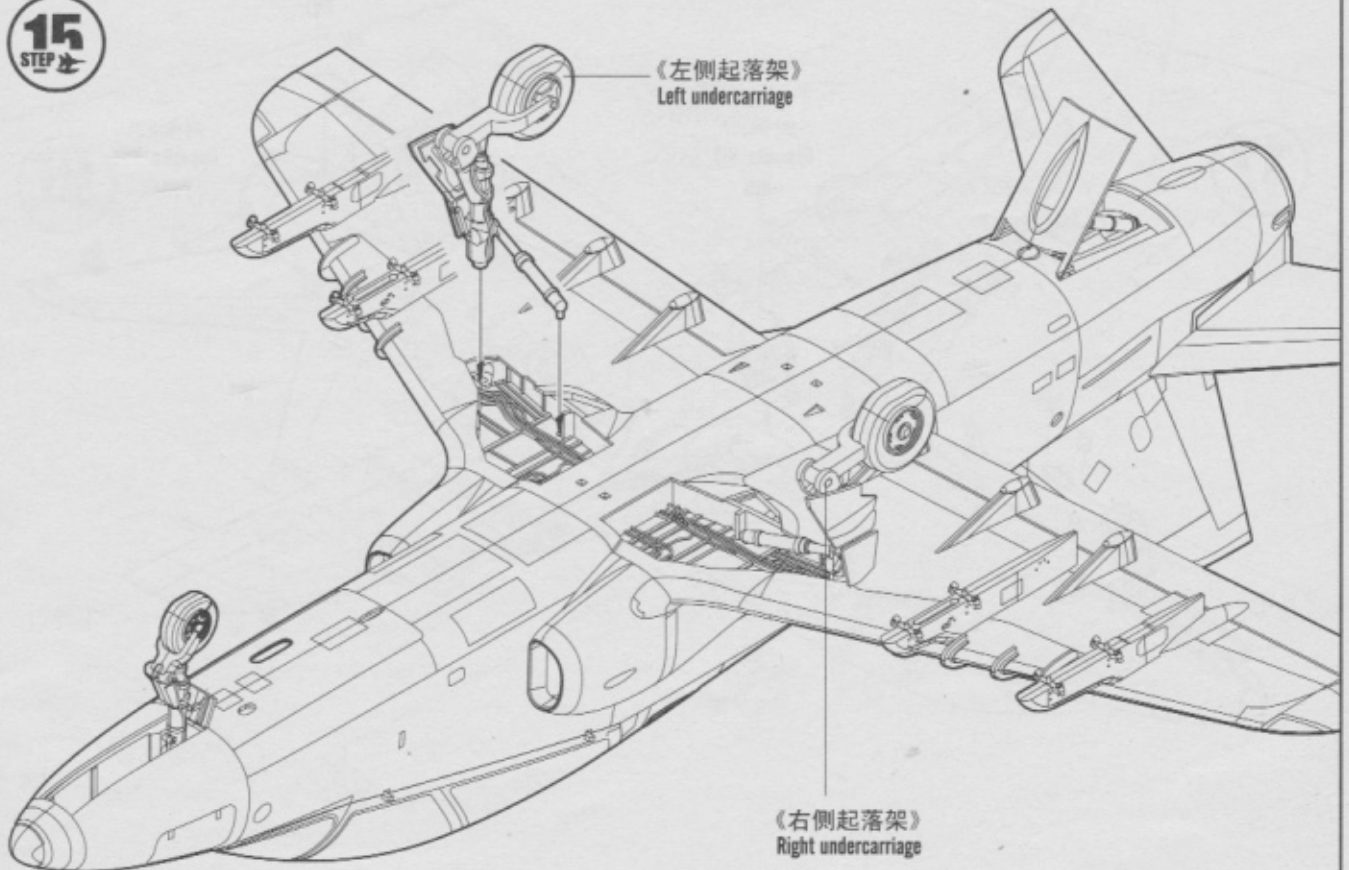

《右侧起落架》
Right undercarriage

16
STEP 全

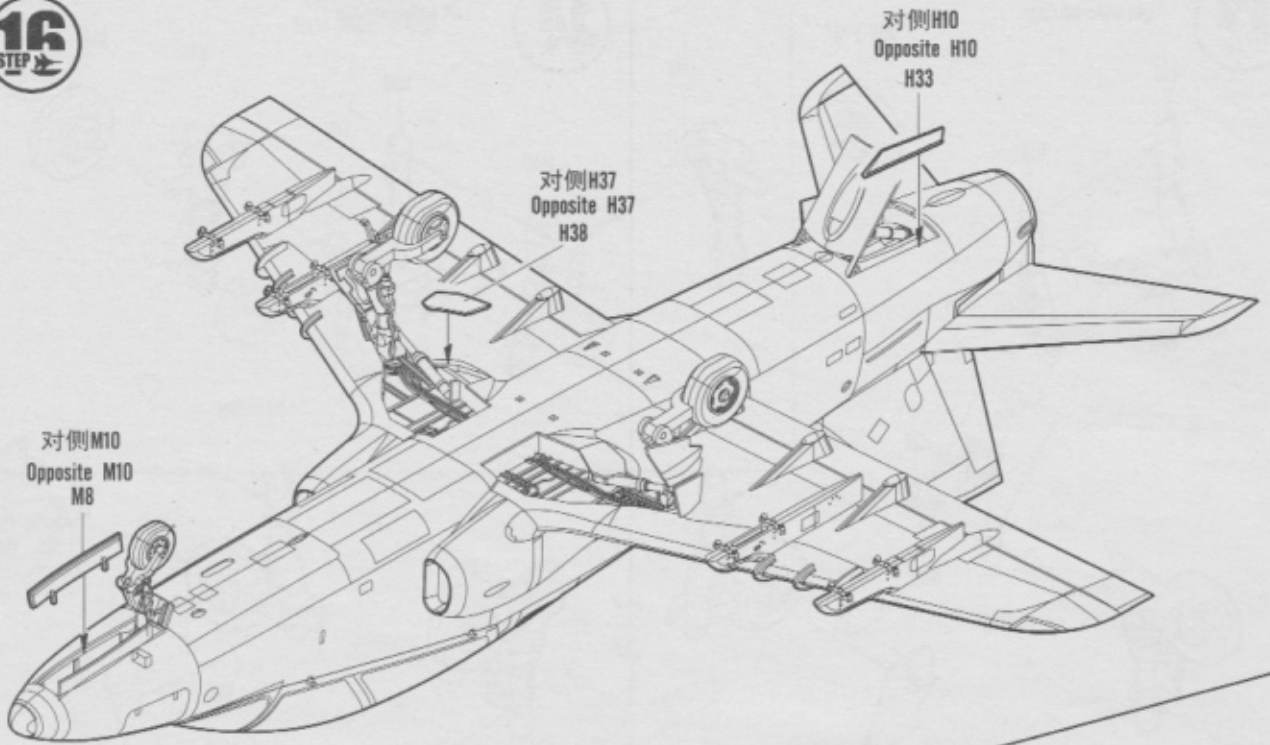

17
STEP 全

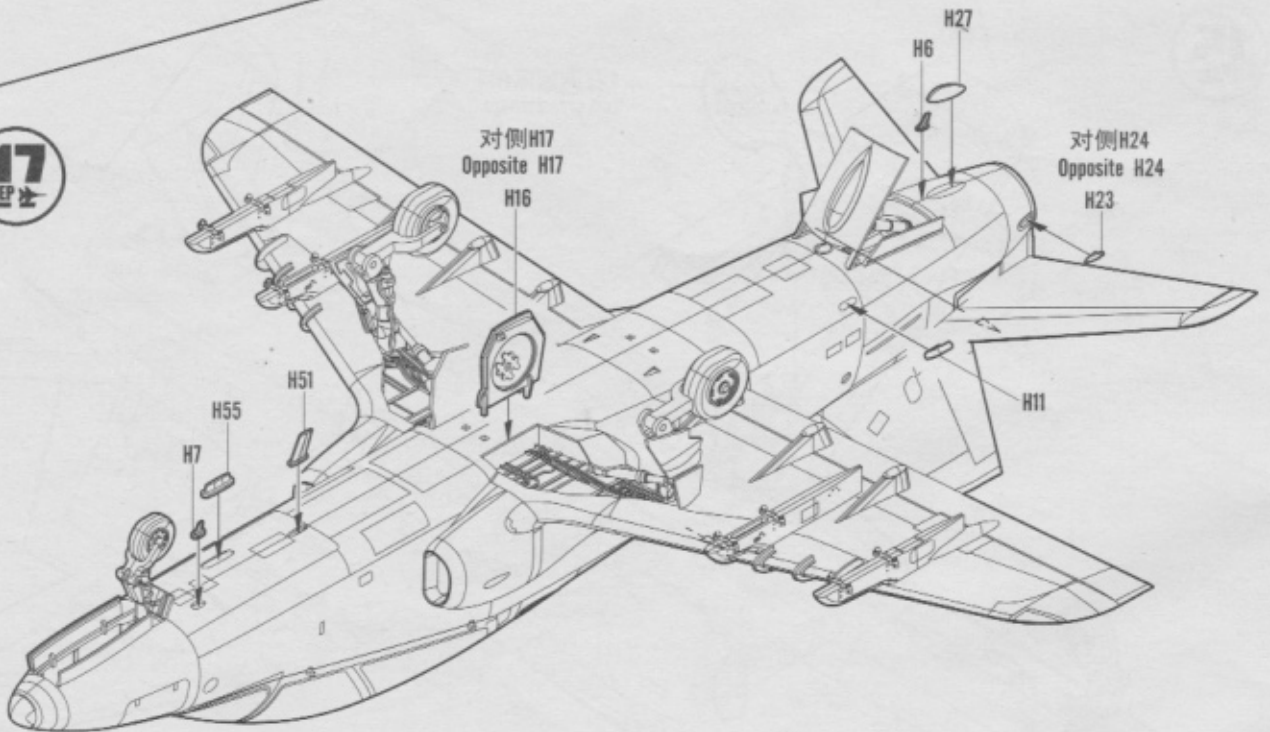

18
STEP →

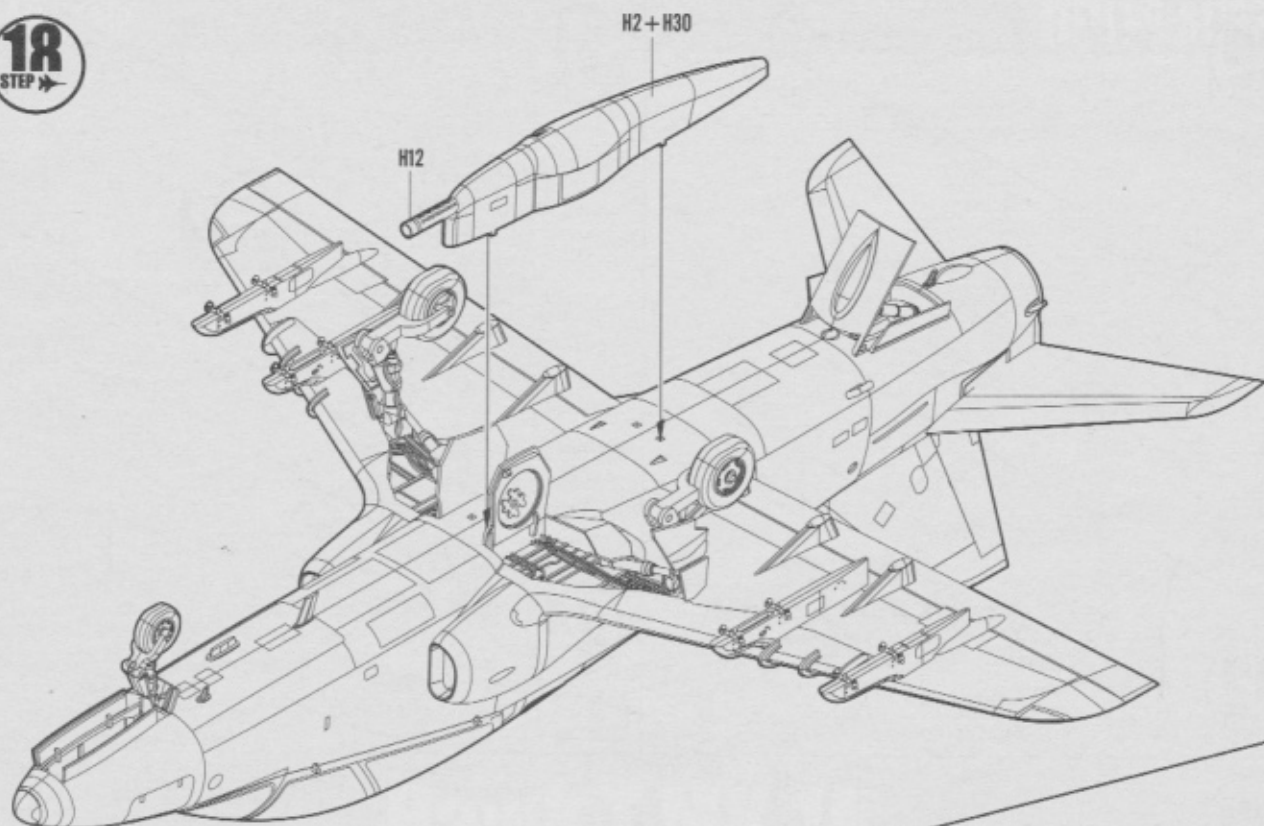

19
STEP →

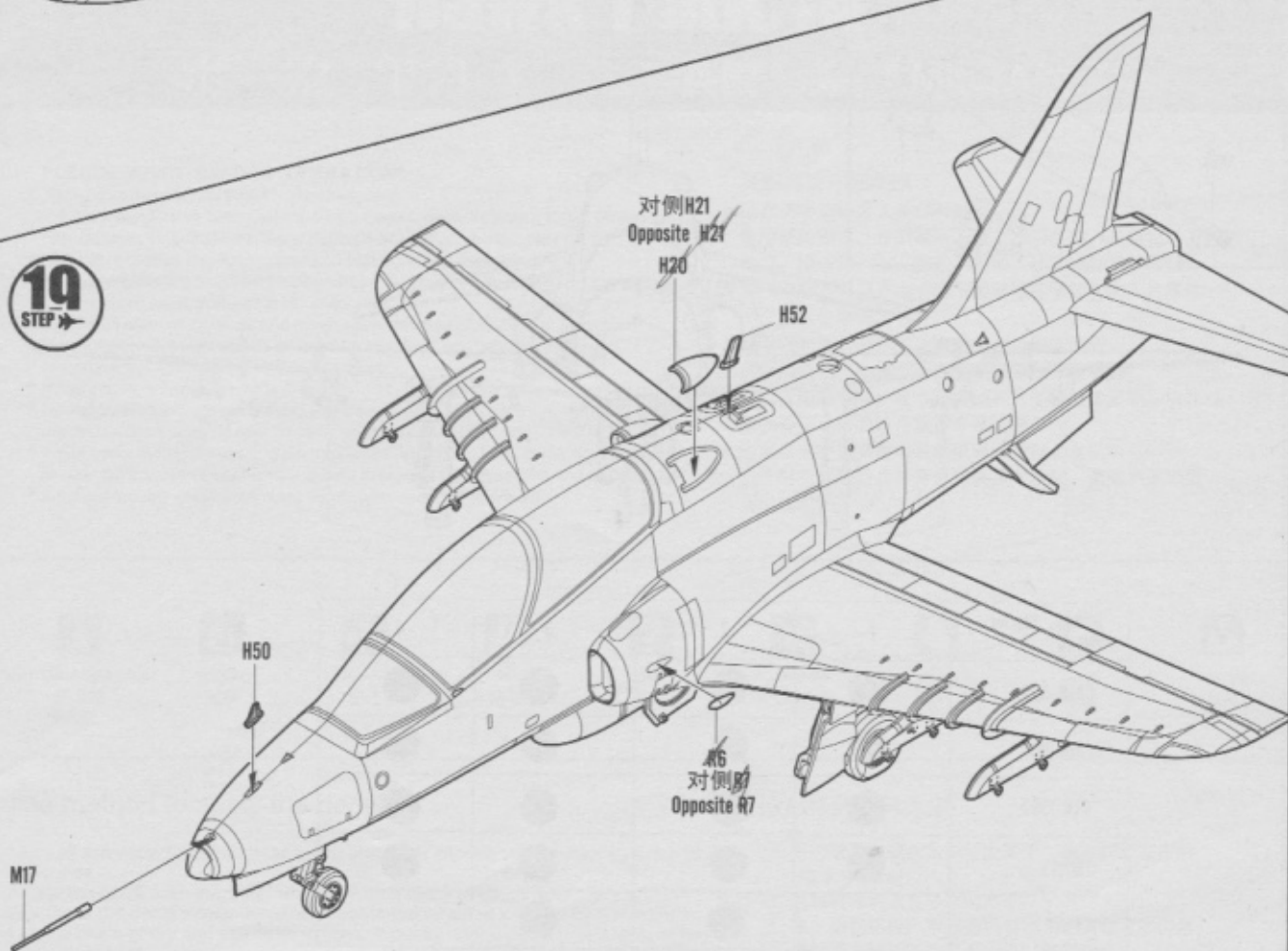

20
STEP

《AIM-9P》

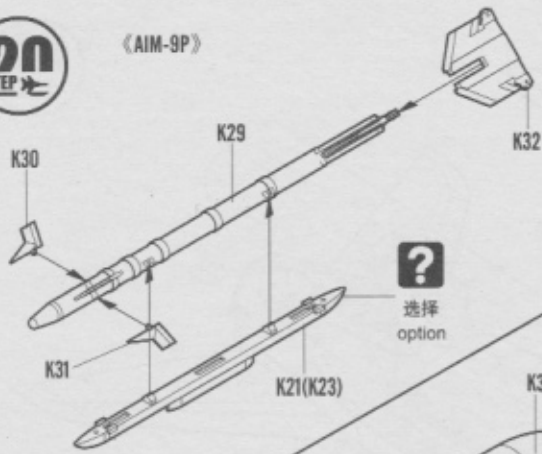

?

选择
option

制作2组
Make Two

22
STEP

《LR-155》

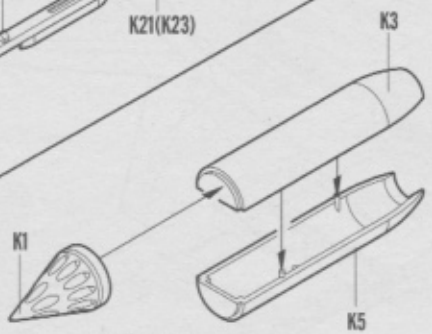

制作2组
Make Two

21
STEP

《AIM-9L》

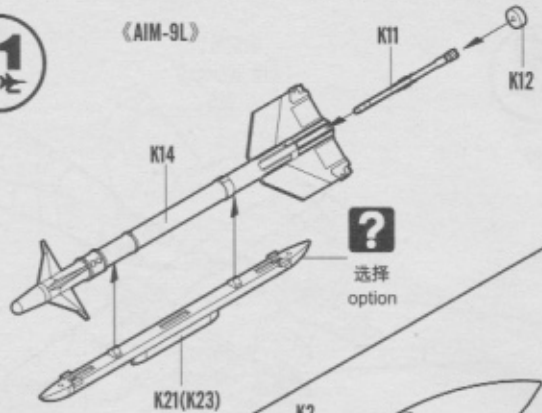

?

选择
option

制作2组
Make Two

21
STEP

《TANK》

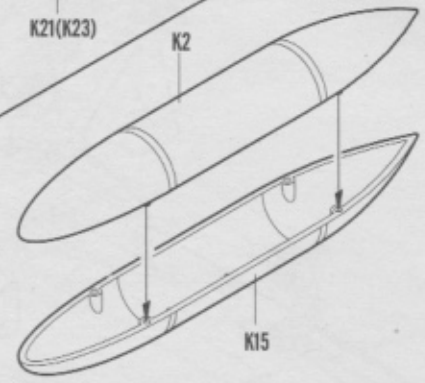

制作2组
Make Two

23
STEP

《M117》

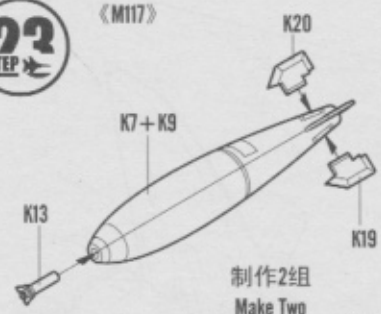

制作2组
Make Two

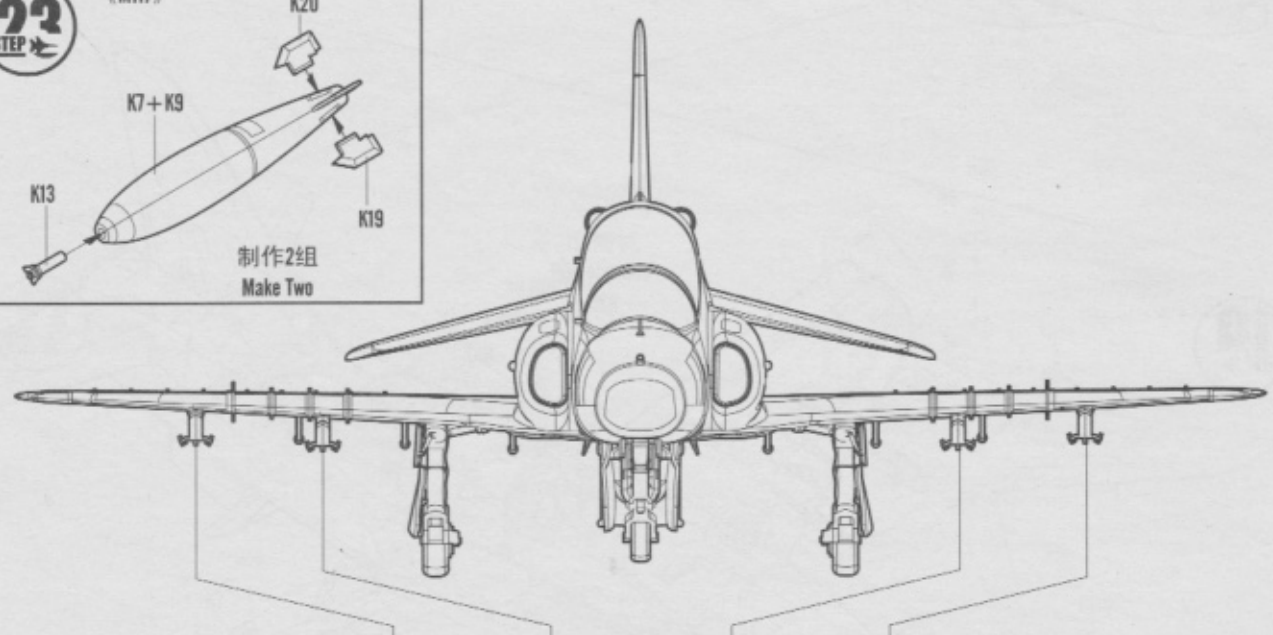

Sta.No.	1	2	3	4
Missile				
《AIM-9L》	●	●	●	●
《AIM-9P》	●	●	●	●
《LR-155》	●	●	●	●
《M117》	●	●	●	●
《TANK》		●	●	

I BAe Hawk T Mk 1A, XX256 of No 2 Tactical Weapons Unit, (No 63 'Shadow' Squadron), RAF Chivenor circa 1981

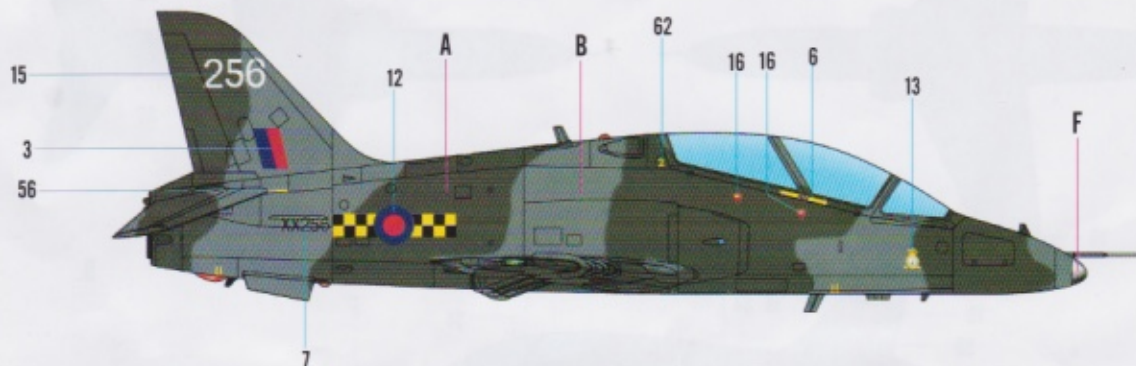
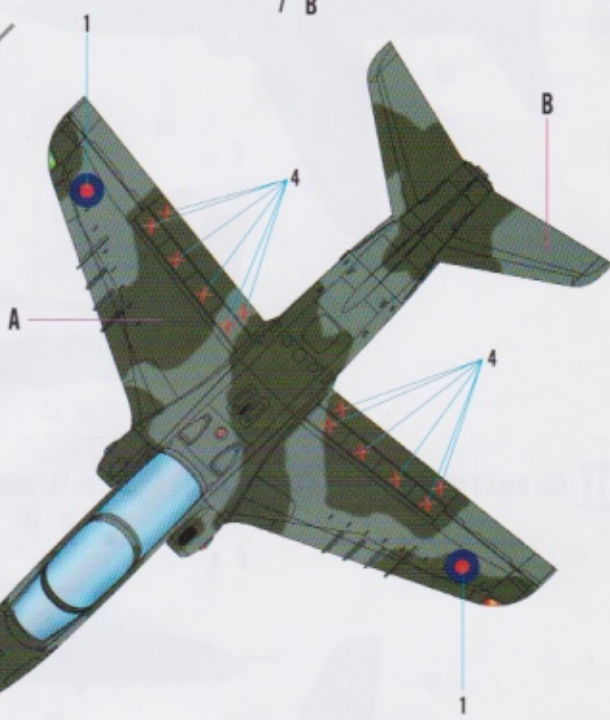
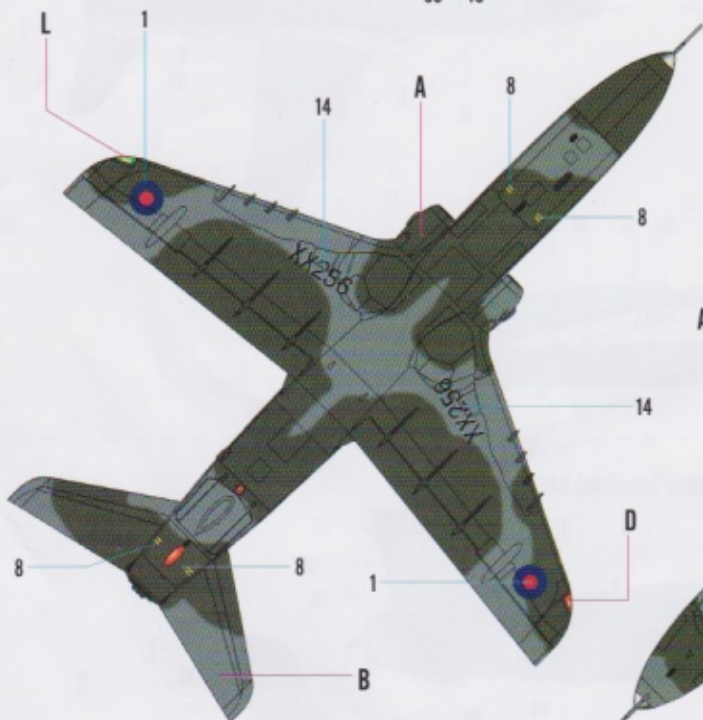

AIM-9L x2

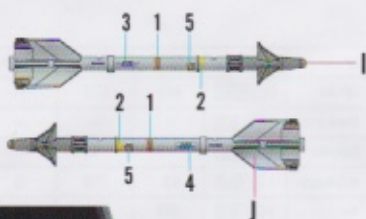

AIM-9P x2

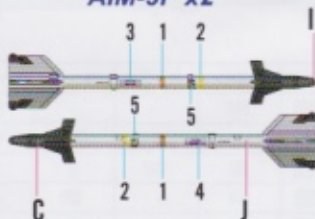

M117 x2



II BAe Hawk T Mk 1A, XX341 of the Empire Test Pilots School, Advanced Systems Training Aircraft (ASTRA), Boscombe Down, 2000

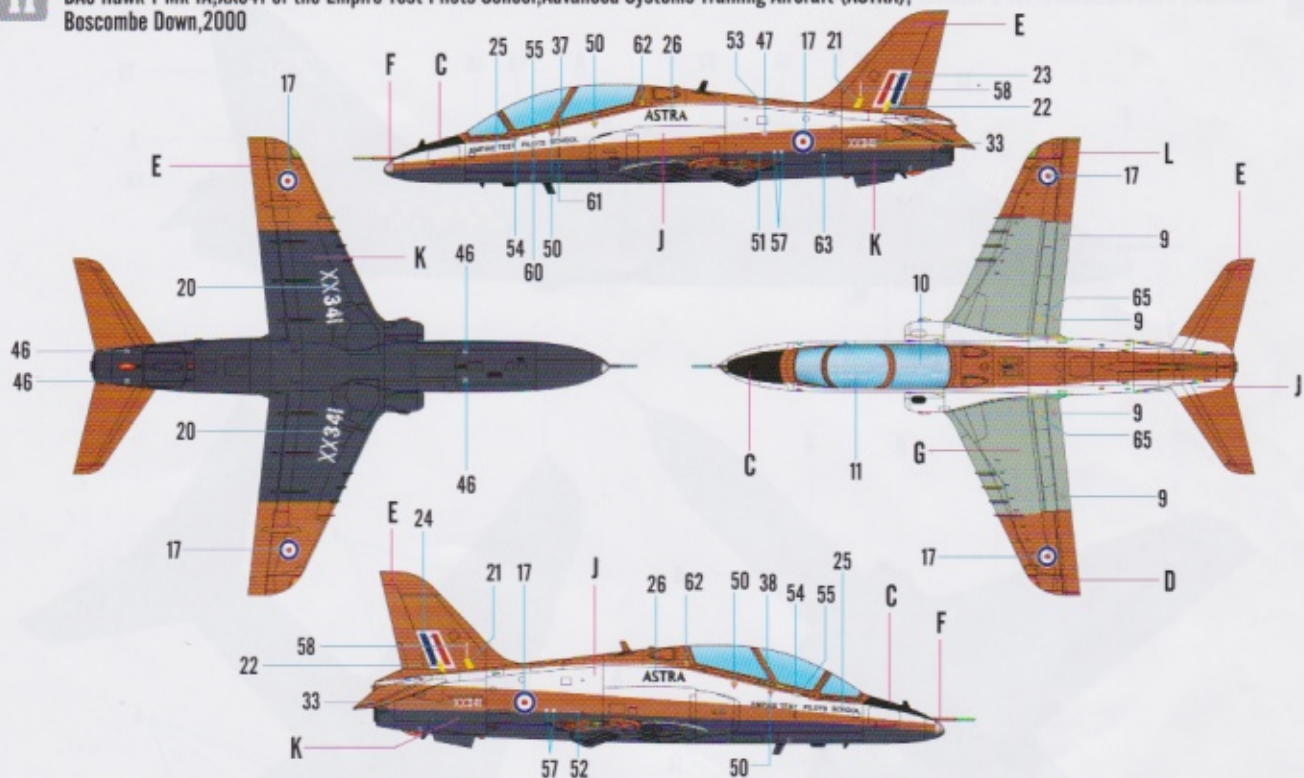

III BAe Hawk T Mk 1A, XX226, of No 4 Flying Training School, (No 74 'shadow' Squadron), RAF Valley, 2001

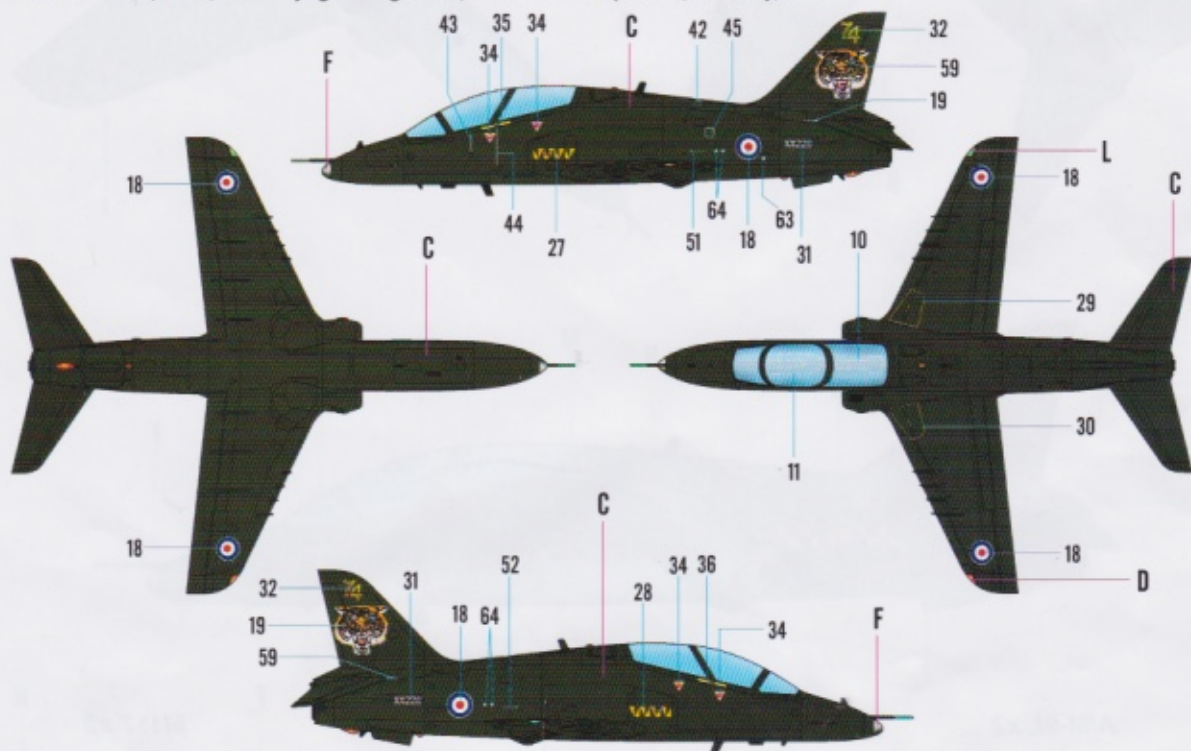

Color	Mr.Hobby	Vallejo	Model Master	Tamiya	Humbrol	Color	Mr.Hobby	Vallejo	Model Master	Tamiya	Humbrol
A 深绿色 Dark Green Gs381 C/G41	H[30] 330	892	--	--	163	G 灰色 Light Gull	H[110] 315	843	1730	--	129
B 深海灰 Dark Seagray Gs381 C/G38	H[30] 331	--	--	XF54	164	H 橄榄色 Olive Drab (2)	H[70] 30	--	--	--	--
C 黑色 Black	H[2] 2	861	1747	X1	21	I 烟灰色 Smoke Blue	H[90] 101	--	--	--	--
D 透明红 Clear Red	H[80] 47	934	--	X27	--	J 白色 White Insignia	H[110] 310	991	1745	X2	22
E 红色 Insignia Red	H[82] 327	957	1705	XF7	153	K 蓝色 Blue	H[5] 5	899	1745	X2	22
F 银色 Silver	H[18] 8	997	1546	X11	11	L 透明绿 Clear Green	H[91] 102	--	--	--	--