

1/35 SCALE

35GM0071

**English** When the mechanisation of the British Army was accelerated in the late 1930s, a number of the major commercial vehicle manufacturers in Britain supplied 30cwt capacity General Service trucks to the British Army. These were often a militarised version of the standard commercial truck offered by these companies. Early examples, reflecting First World War and 1920's practice had an open cab, with simple canvas aprons to give the crew a measure of weather protection. Given the limited funding available for military equipment in the 1930s, the simple development of commercially available trucks into trucks for the Army appeared to be a cost-effective solution, requiring small development costs. Later examples of these open cab trucks, often referred to by their drivers as "pneumonia wagons" were fitted with a standardised pressed steel full cab which was also often seen fitted to other larger trucks from the same manufacturer. Production of the 30cwt capacity of trucks did not last long as it was found that they cost as much to produce as a 3 ton truck with twice the capacity. A large number of trucks were lost during the Battle of France and were subsequently refurbished for use by the Wehrmacht. Trucks with this appearance were often seen in use with Home Forces and in the Western Desert. With the final British demise of interest in the 30cwt class of vehicles as a load carrier, remaining vehicles were either used for second line use including driver training or passed to Allied Forces. This included being lend-leased to Soviet Forces.

Story by Simon King

**Deutsch** Als die Mechanisierung der britischen Armee in den späten 1930ern beschleunigt wurde, versorgten eine Reihe der großen Nutzfahrzeughersteller in Großbritannien die britische Armee mit General Service Trucks mit einer Kapazität von 30 cwt. Diese waren oft eine militarisiertere Version des Standard-Nutzlastwagens, der von diesen Unternehmen angeboten wurde. Frühe Muster, die die Bauweise des Ersten Weltkriegs und der 1920er Jahre widerspiegeln, hatten eine offene Kabine mit einfachen Segeltuchschürzen, um der Besatzung ein Mindestmaß an Wetterschutz zu geben. Angesichts der begrenzten verfügbaren Mittel für militärische Ausrüstung in den 1930er Jahren war die einfache Weiterentwicklung der verfügbaren zivilen LKW in Lastwagen für die Armee eine kostengünstige Lösung, die nur geringe Entwicklungskosten erforderte. Spätere Exemplare der offenen Kabinenlastwagen, die von ihren Fahrern oft als "Lungenentzündungswagen" bezeichnet wurden, wurden dann mit einem genormten Stahlblech-Vollfahrerhaus ausgestattet, das ebenfalls oft an andere größere Lkw des gleichen Herstellers eingebaut wurde. Die Produktion der 30cwt-Kapazitäten von LKW hielt nicht lange an, da festgestellt wurde, dass sie so viel kosteten wie ein 3-Tonner mit doppelter Kapazität. Eine große Anzahl an LKW ging während der Schlacht um Frankreich verloren und wurden später für die Wehrmacht umgebaut. LKW mit diesem Aussehen waren oft im Einsatz bei den Heimatstreitkräften und in der westlichen Wüste. Mit dem Ende des britischen Interesses an der 30cwt-Fahrzeugklasse als LKW, wurden die verbleibenden Fahrzeuge entweder für den Einsatz im Hinterland einschließlich Fahrerausbildung verwendet oder an die Alliierten übergeben. Dies beinhaltete die Lend-Lease Lieferungen an sowjetische Streitkräfte.

Translation by Thomas Hartwig

**繁體中文** 20世紀30年代末，當英國軍隊的機械化進程加快時，英國的一些主要商用車製造商向英國軍隊提供了容量為30 CWT的通用卡車。這些卡車通常是這些公司提供的標準商用卡車的軍事化版本。早期的例子，按照第一次世界大戰和1920年代的通常做法，都有一個開放式駕駛室，帶有簡單的帆布圍裙，為乘員提供一定程度的天氣保護。考慮到20世紀30年代用於軍事裝備的資金有限，將商用卡車簡單地開發成陸軍用卡車似乎是一個成本效益高的解決方案，只需要少量的開發成本。後來，這些開放式駕駛室卡車（通常被司機稱為“肺炎貨車”）安裝了一個標準化的衝壓鋼制全駕駛室，也經常被視為安裝在同一製造商的其他大型卡車上。30cwt卡車的生產並沒有持續多久，因為人們發現，生產30cwt卡車的成本相當於3噸卡車的两倍。這類卡車在二戰初英軍撤出法國時大量丟失，隨後被德軍整修以後供其國防軍使用。這種的英軍卡車通常供應給其本土部隊和北非沙漠中使用。隨著英國最終放棄了對30cwt級運載工具的興趣，剩下的車輛要麼用於二線使用，包括駕駛員培訓，要麼被交給盟軍。這包括租借給蘇聯軍隊。

**簡體中文** 20世紀30年代末，當英國軍隊的機械化進程加快時，英國的一些主要商用車製造商向英國軍隊提供了容量為30 CWT的通用卡車。這些卡車通常是這些公司提供的標準商用卡車的軍事化版本。早期的例子，按照第一次世界大戰和1920年代的通常做法，都有一個開放式駕駛室，帶有簡單的帆布圍裙，為乘員提供一定程度的天氣保護。考慮到20世紀30年代用於軍事裝備的資金有限，將商用卡車簡單地開發成陸軍用卡車似乎是一個成本效益高的解決方案，只需要少量的開發成本。後來，這些開放式駕駛室卡車（通常被司機稱為“肺炎貨車”）安裝了一個標準化的衝壓鋼制全駕駛室，也經常被視為安裝在同一製造商的其他大型卡車上。30cwt卡車的生產並沒有持續多久，因為人們發現，生產30cwt卡車的成本相當於3噸卡車的两倍。這類卡車在二戰初英軍撤出法國時大量丟失，隨後被德軍整修以後供其國防軍使用。這種的英軍卡車通常供應給其本土部隊和北非沙漠中使用。隨著英國最終放棄了對30cwt級運載工具的興趣，剩下的車輛要麼用於二線使用，包括駕駛員培訓，要麼被交給盟軍。這包括租借給蘇聯軍隊。

**日文** WWII イギリス陸軍30cwt GSトラック

1930年代後半にイギリス陸軍の機械化が加速したとき、イギリスの主要な商用車メーカーの多くは、30cwtの容量の一般サービストラックをイギリス陸軍に供給しました。これらは多くの場合、標準的な商用トラックの軍事化されたバージョンでした。初期の例では、WWIの車両と同様のオープンキャブがあり、乗組員に天候保護の手段を与えるためのシンプルなキャンバスエプロンが付いていました。1930年代には軍用機器に限られた資金しか利用できなかったため、市販のトラックを陸軍用のトラックに単純に開発することは費用効果の高い解決策であり、開発コストはわずかでした。ドライバーによって「肺炎ワゴン」と呼ばれることが多いこれらのオープンキャブトラックのその後の例には、同じメーカーの他の大型トラックにもよく見られる標準化されたプレス鋼製フルキャブが取り付けられていました。30cwtトラックの生産は、2倍の容量の3トントラックと同じくかなりのコストがかかることがわかったため、長くは続かなかった。フランスの戦いで多数のトラックが失われ、その後ドイツ国防軍が使用するために改装されました。このドイツのトラックは、ホームフォースや西部砂漠で使用されているのがよく見られました。イギリス軍は30cwtクラスの車両への関心を失ったため、残りの車両はドライバートレーニングなどの二次使用に使用されるか、連合軍に渡されました。

# Sprue Parts List

(C) x1

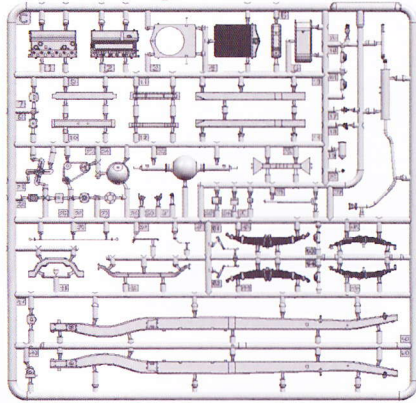

(Ca) x1

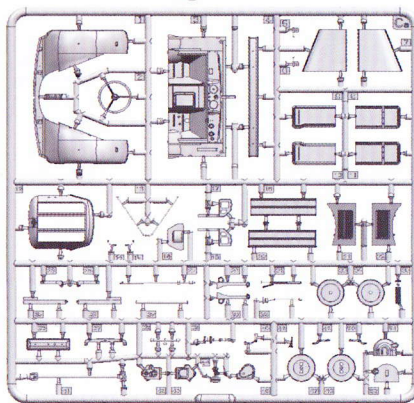

(G) x1

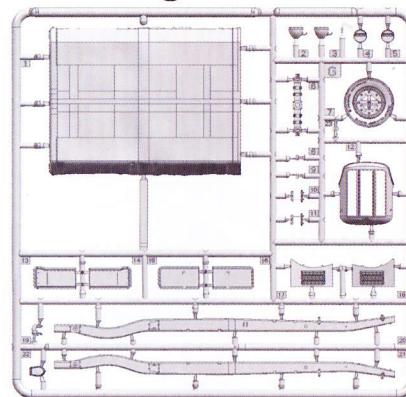

(Ga) x1

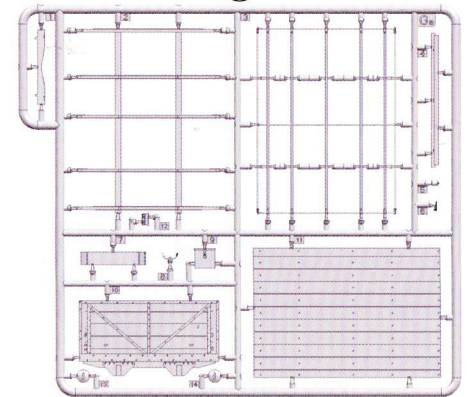

(J) x1

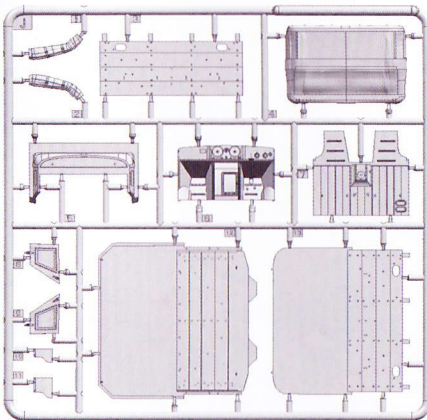

(Ja) x1

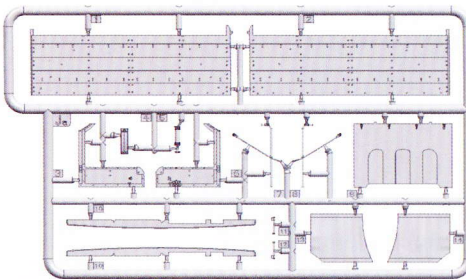

(D) x2

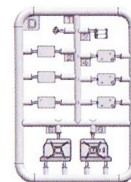

(Da) x2

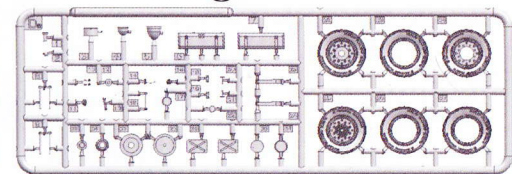

(Jc) x1

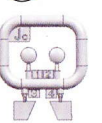

(Ka) x2

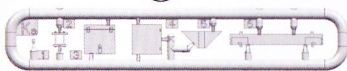

(Bf) x4



(G) x1

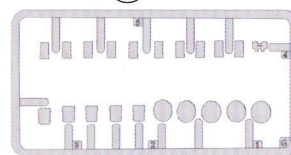

(F) x1

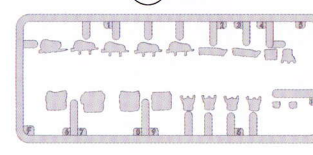

(D) x1

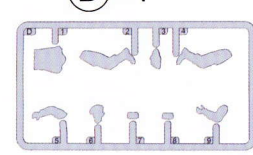

(Eb) x1

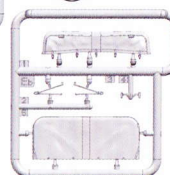

(T) x1

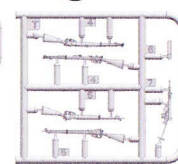

(K) x5



Hose x1



(P) x1

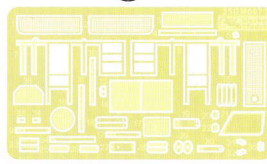

Decal x1



削、模型工具刀、小鋏子、柔軟綿布及砂紙去協助制作。

いようにご注意ください。

オペンナ、模型用ナイフ、精密工作用金属製やすり、  
てご用意をお勧めします。

も使用して下さい。塗装ガイドと各メーカー指定色はキ

部品の透明塑料袋を頭上、這很容易引致窒息。

下さい。

す。小さなお子様の手が届かないようご注意ください。

鋭角なものもあり危険です。ご家族のため、細心の

Do not cement  
Nicht kleben

Read  
Lesen

1. 將需要貼上水貼之部位表面擦乾淨。
2. 將所需之貼紙剪下泡在清水裡約15至20秒。
3. 將濕透之貼紙取出置放於正確之位置旁。
4. 用棉花棒輕推貼紙表面使其從底紙滑出至  
模型表面之正確位置。
5. 待其自然幹透後即完成。

1

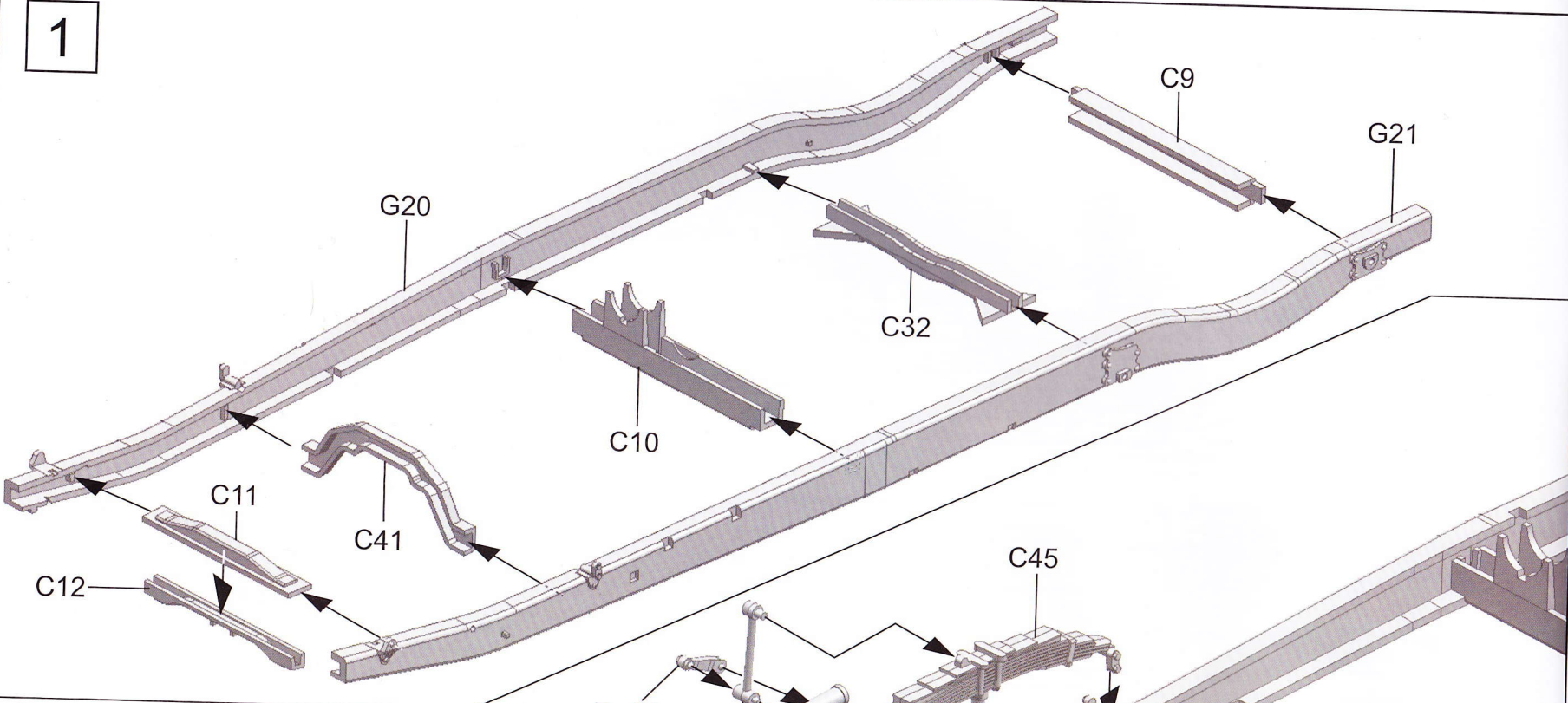

2

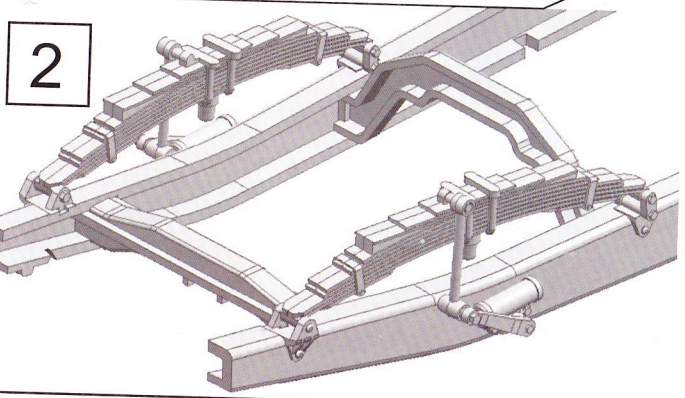

4

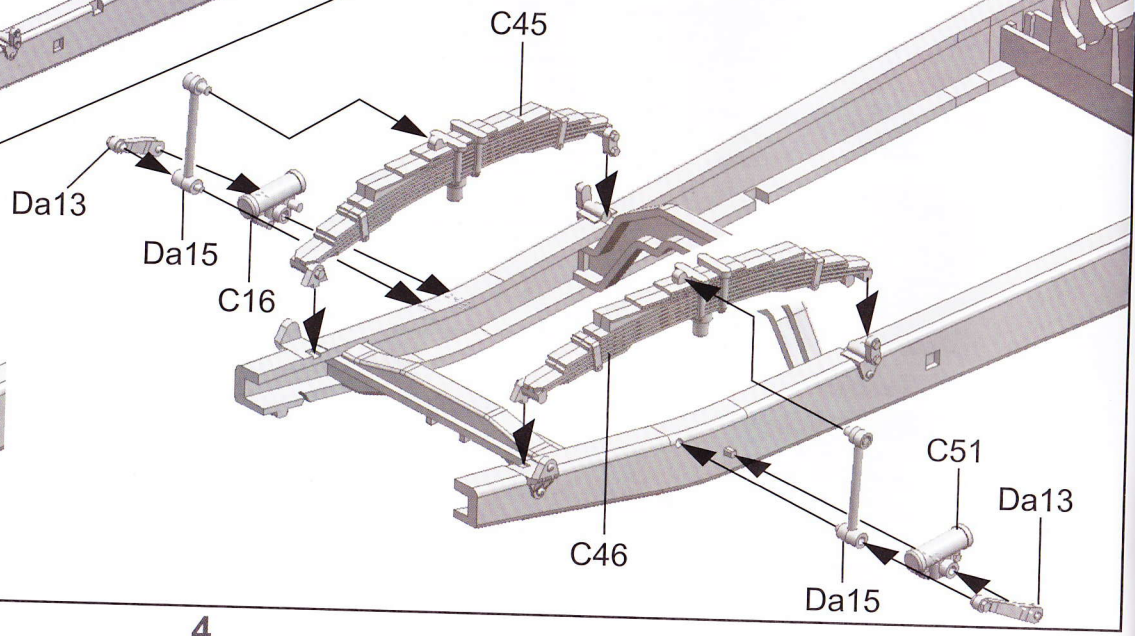

3

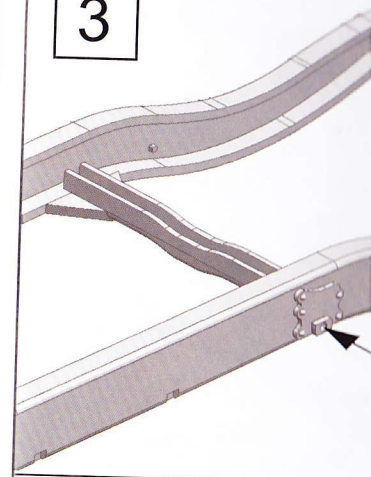

4

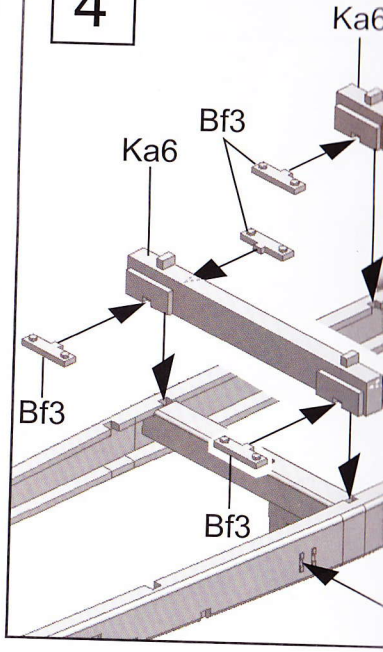

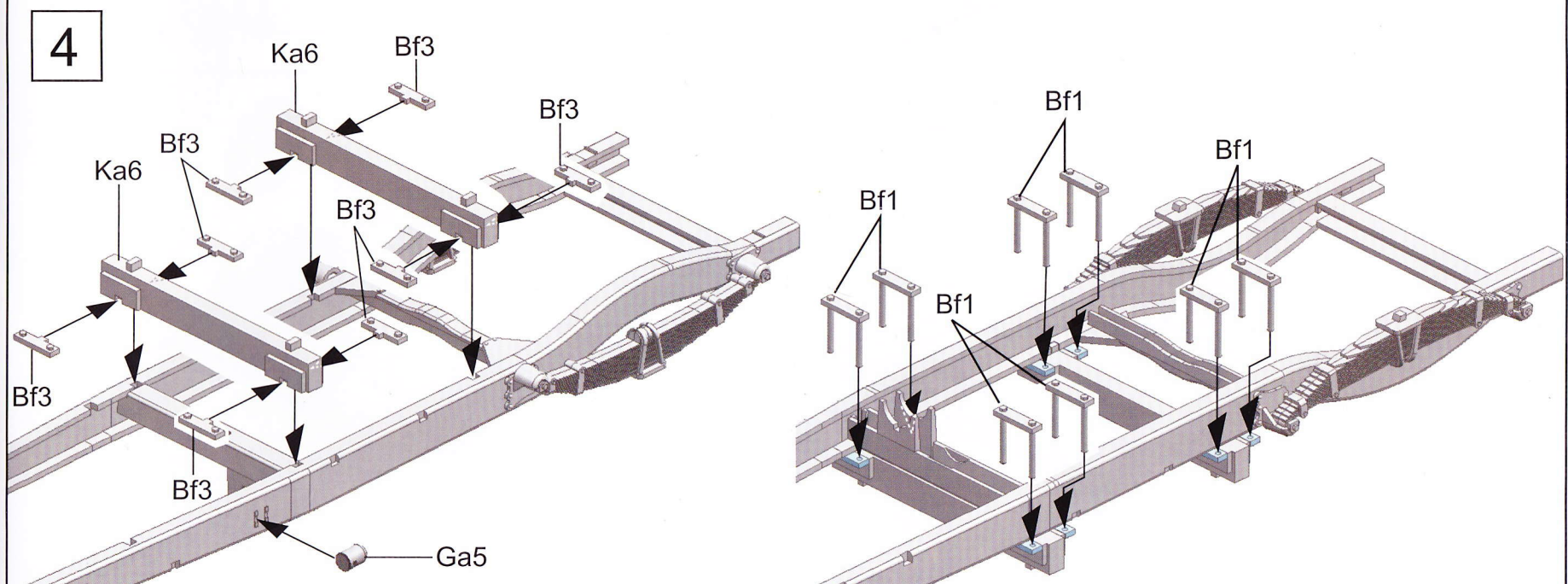
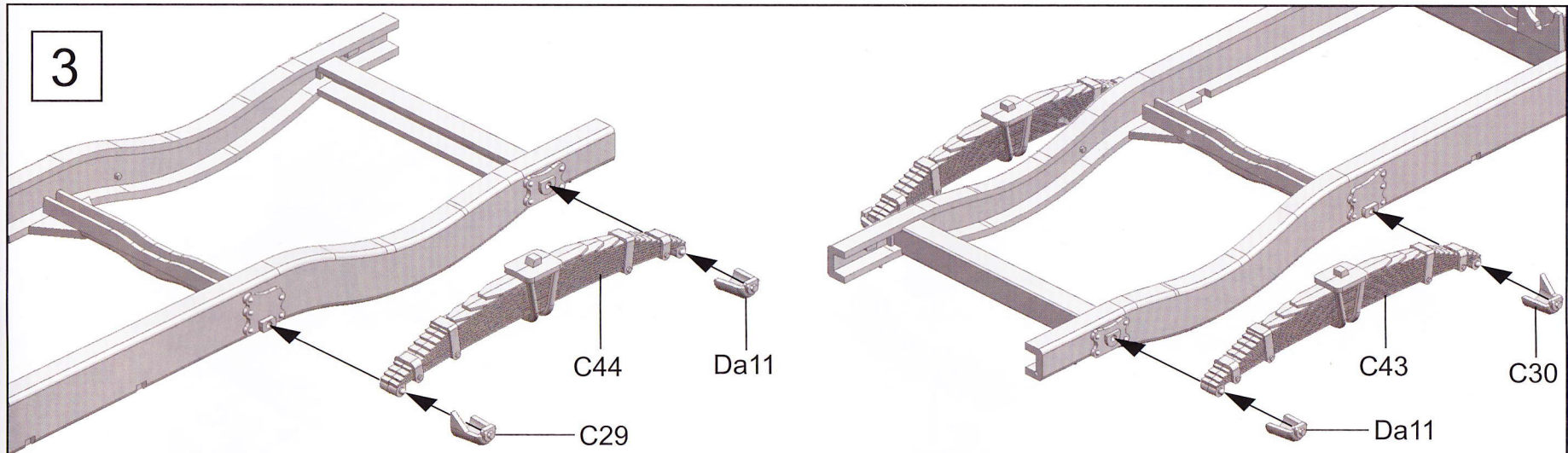

5

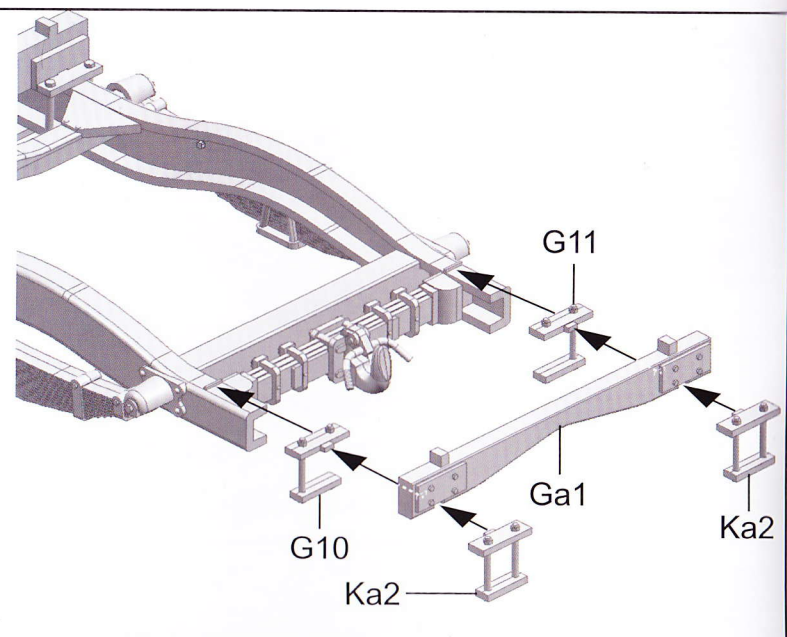
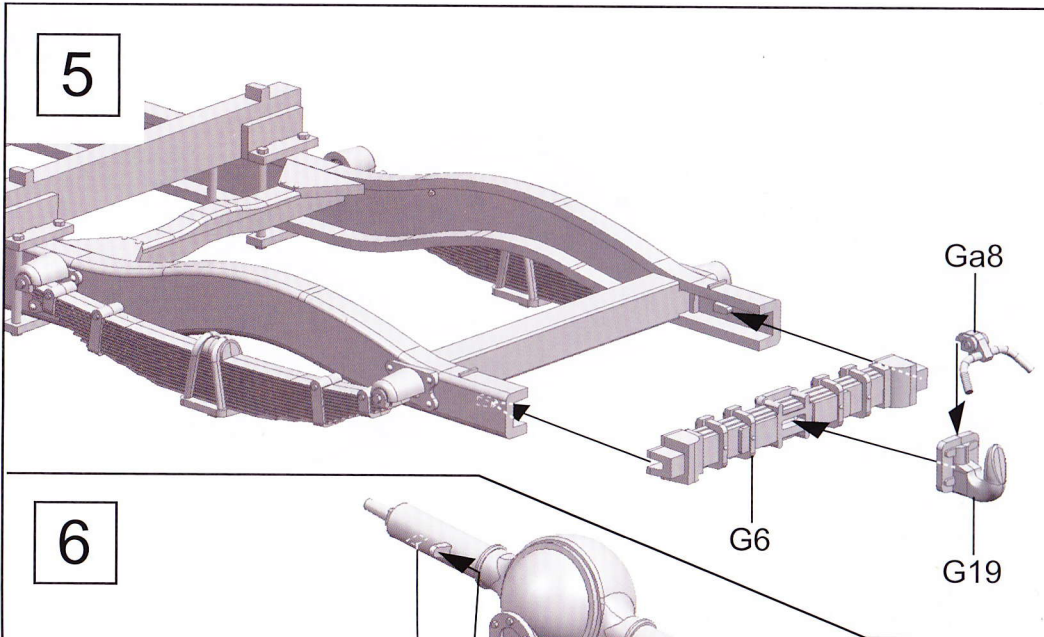

6

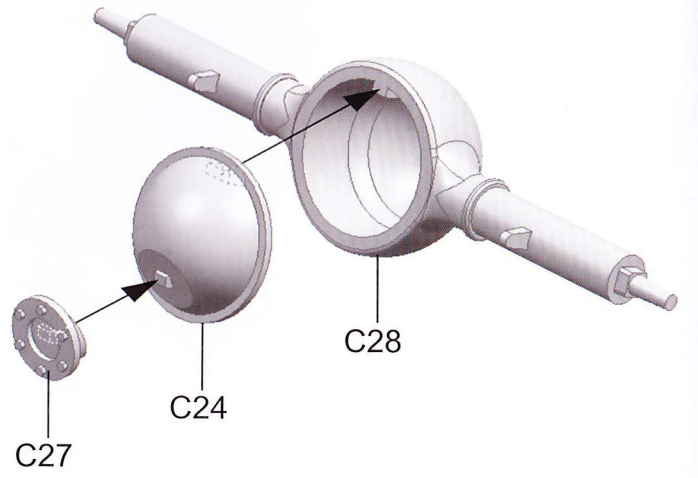
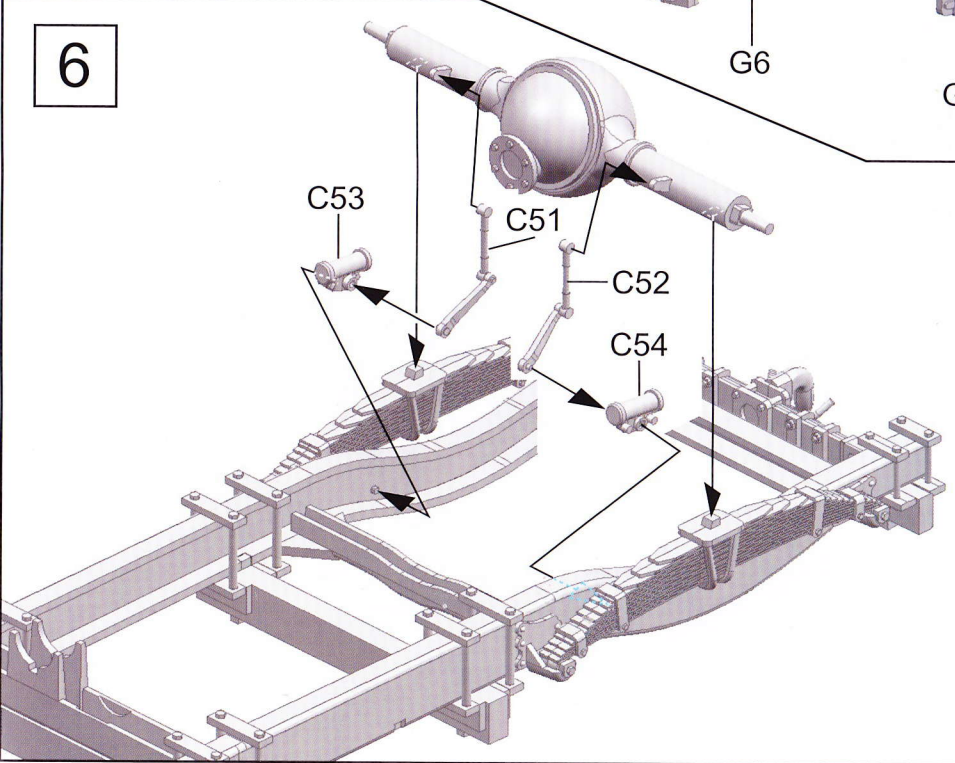

6

7



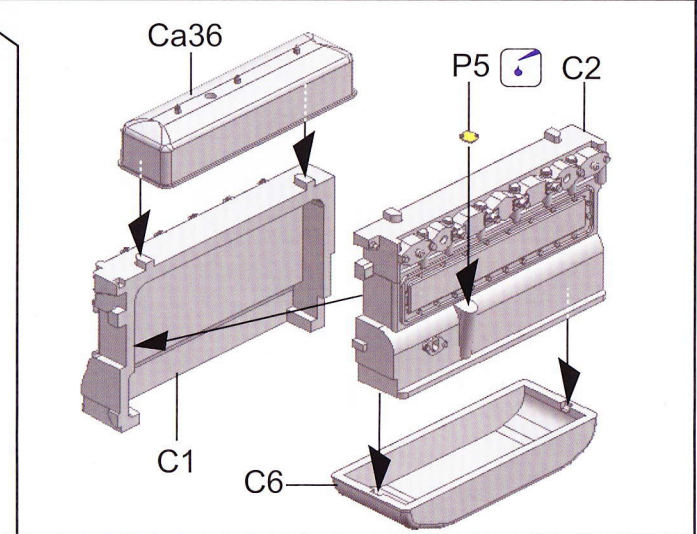
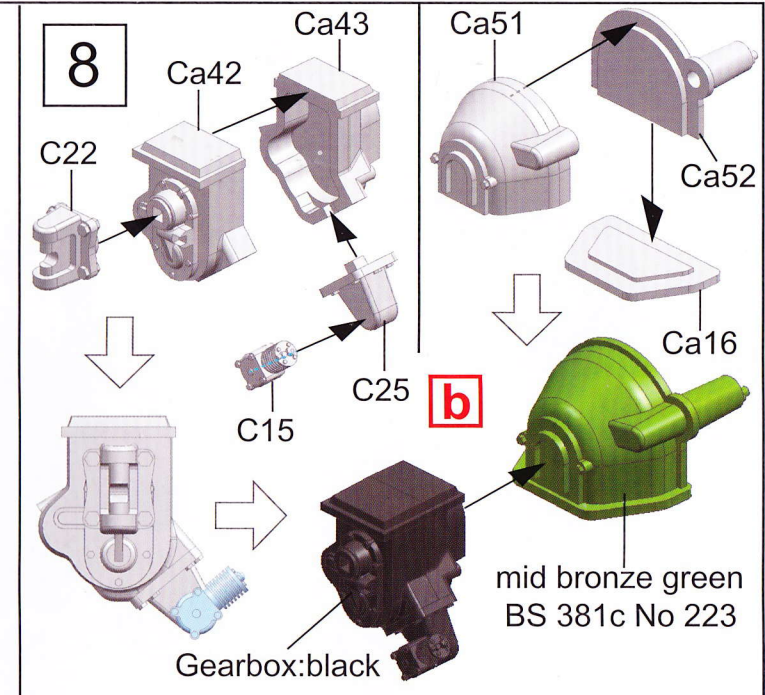
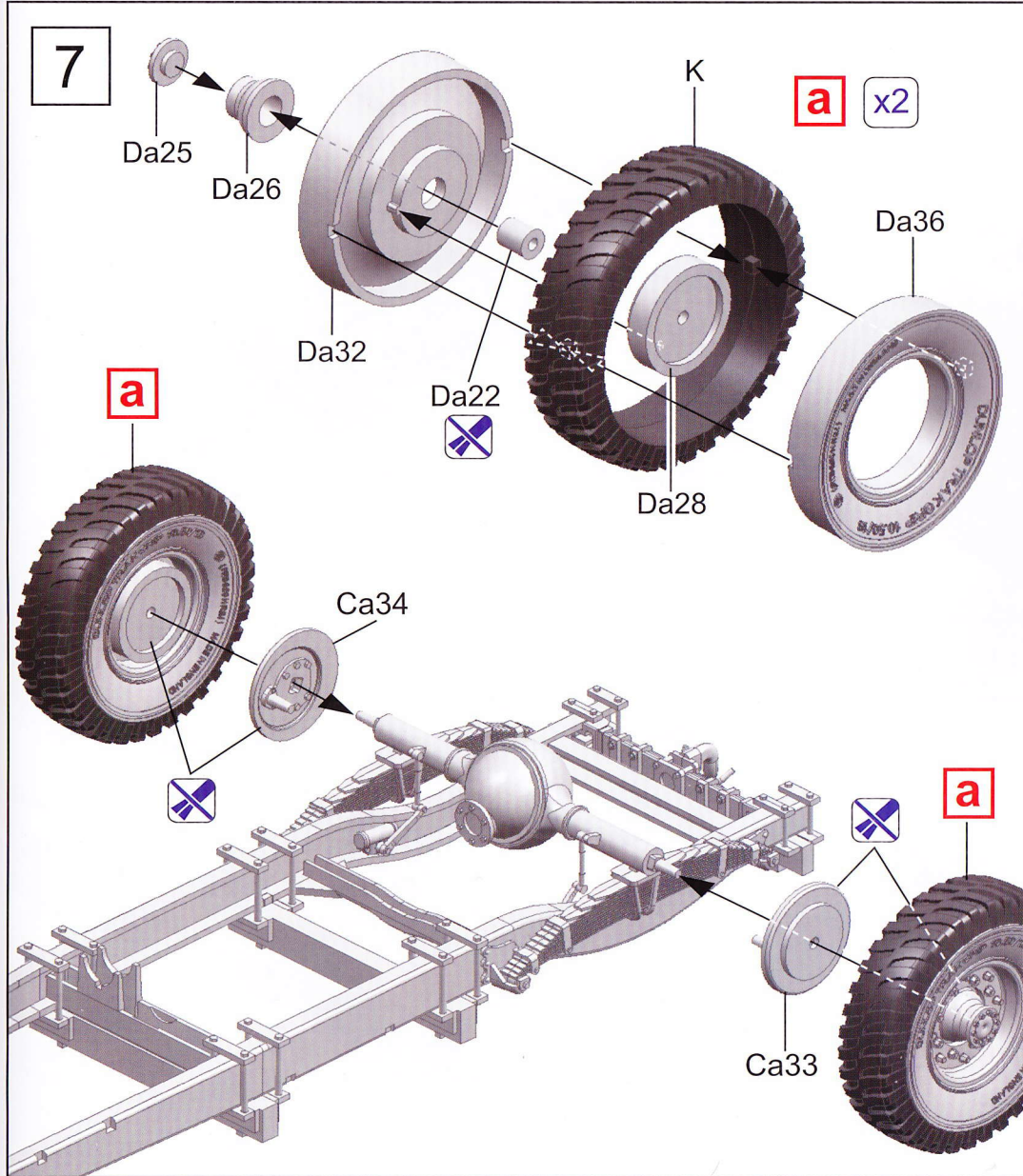
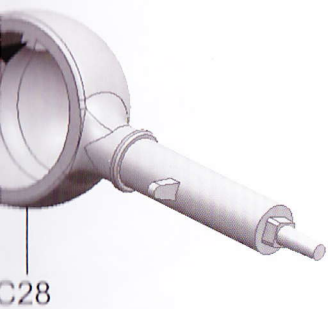
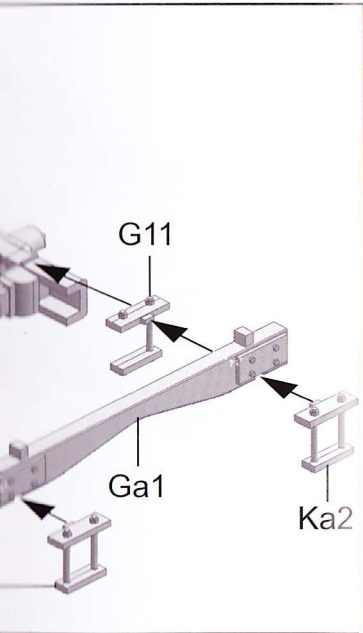

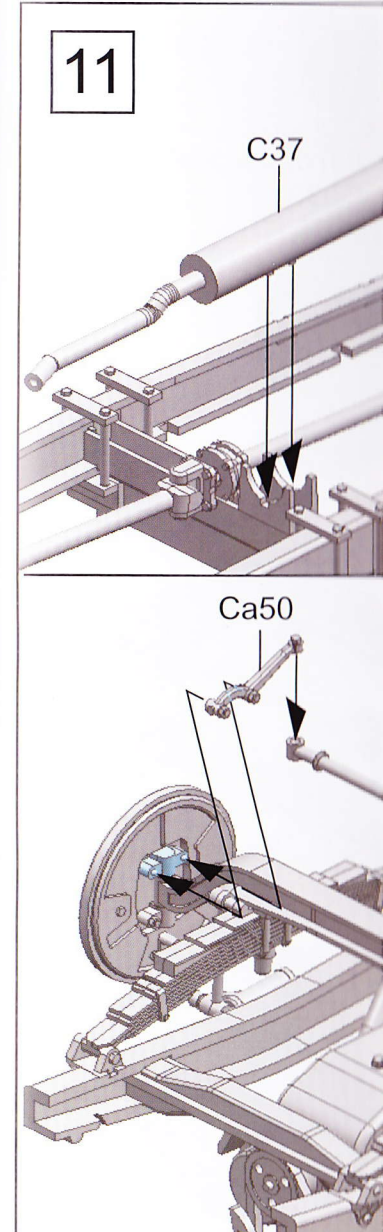
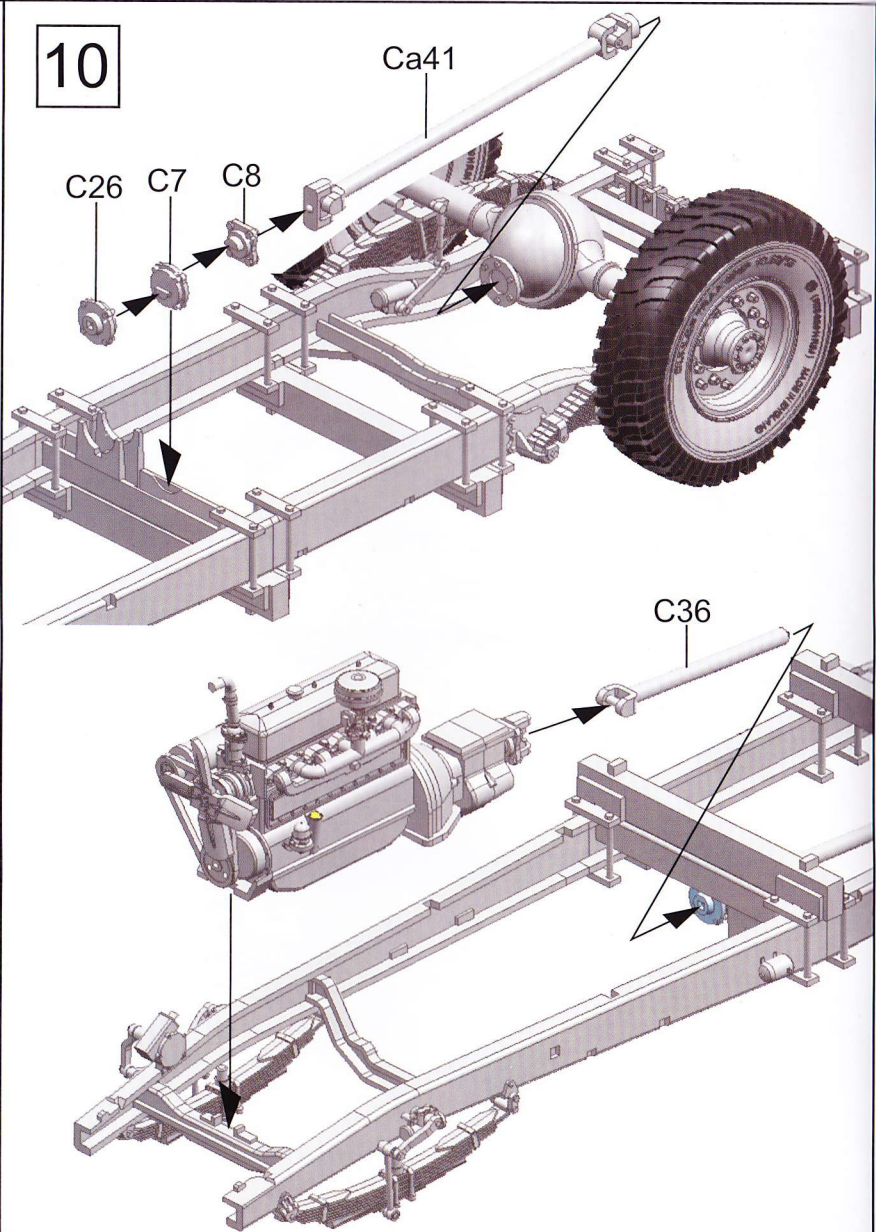
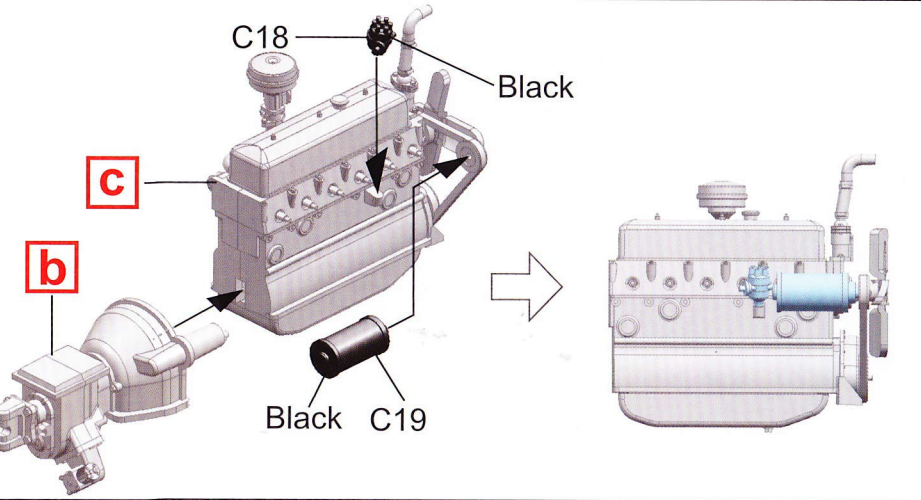
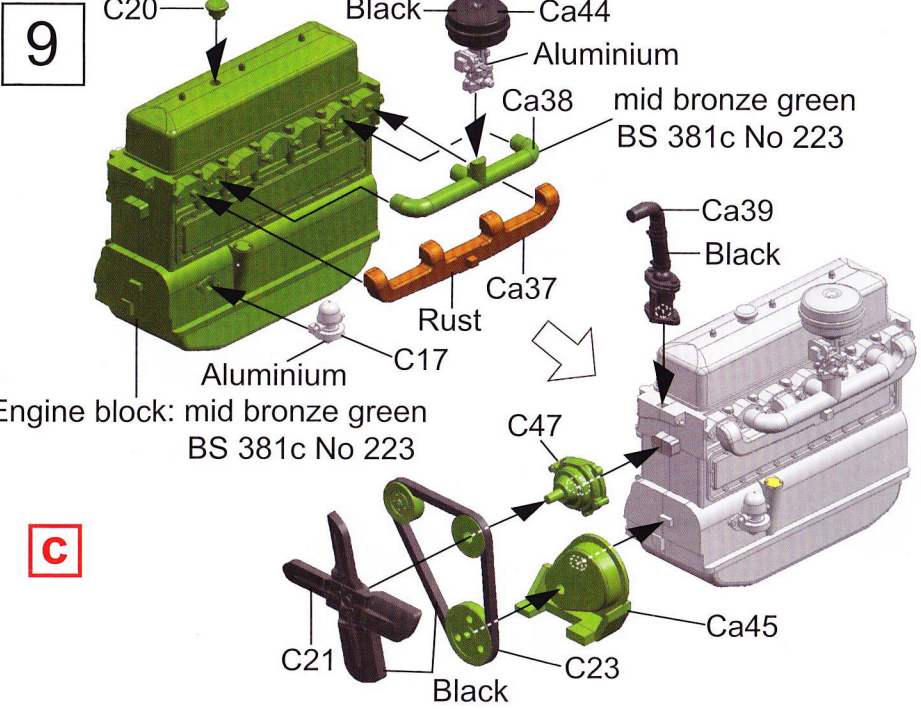

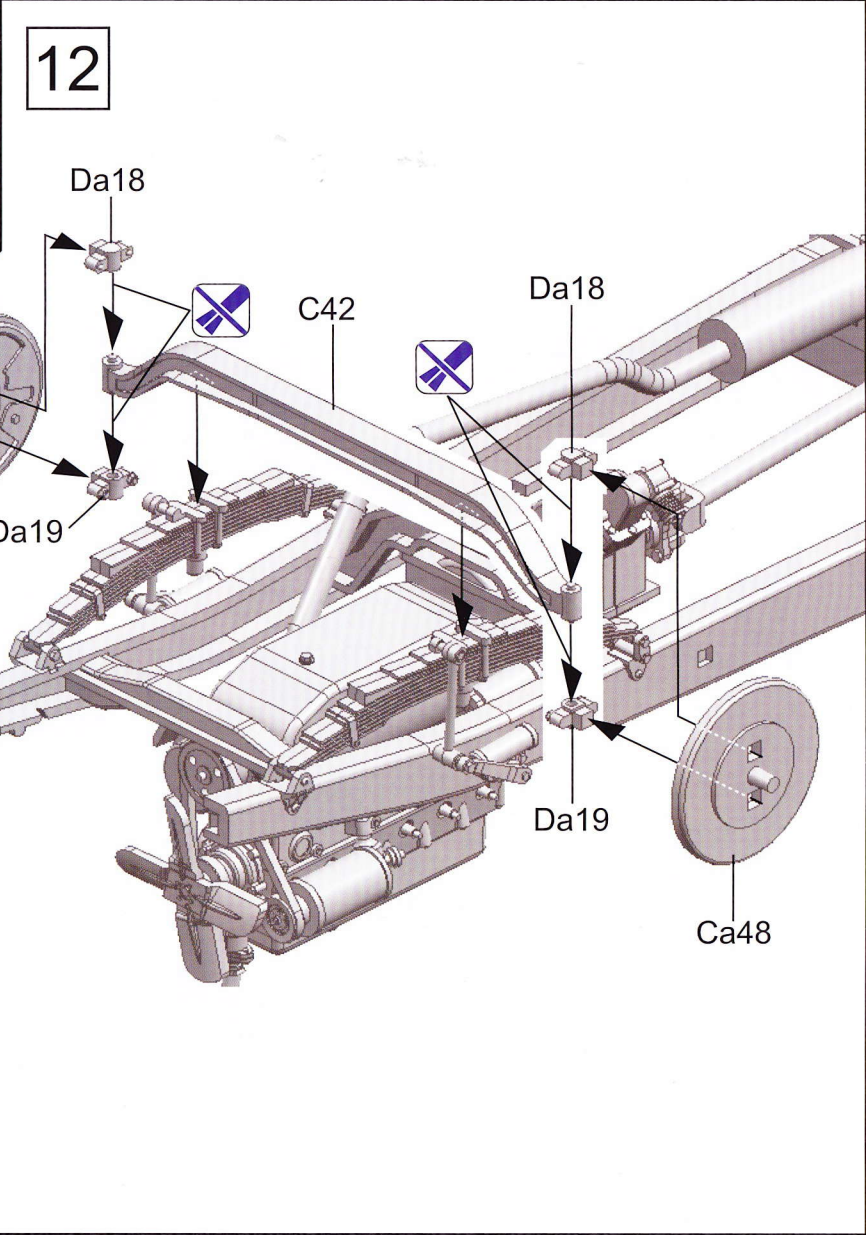
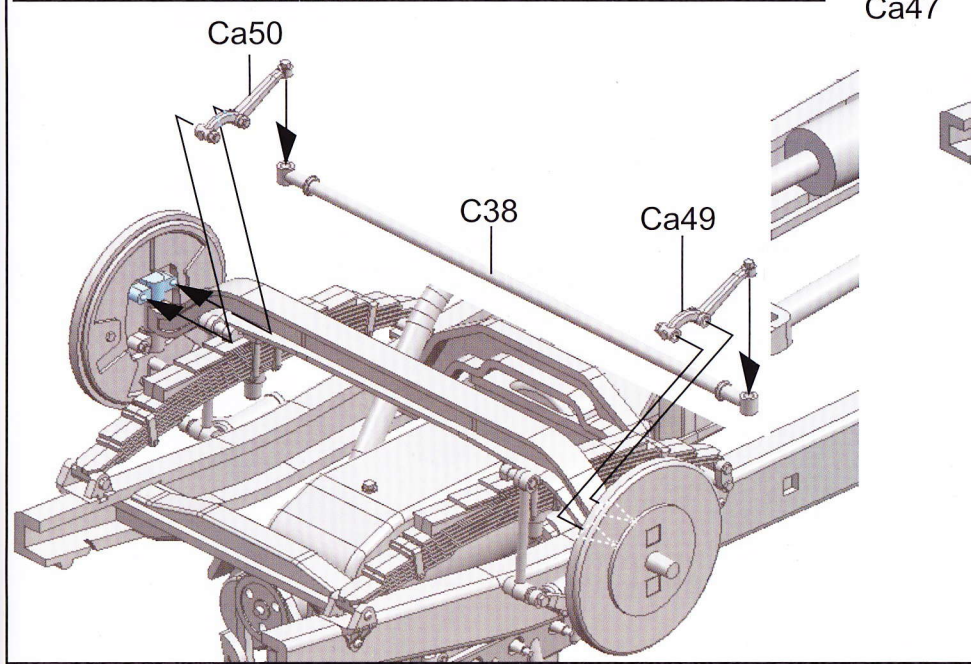
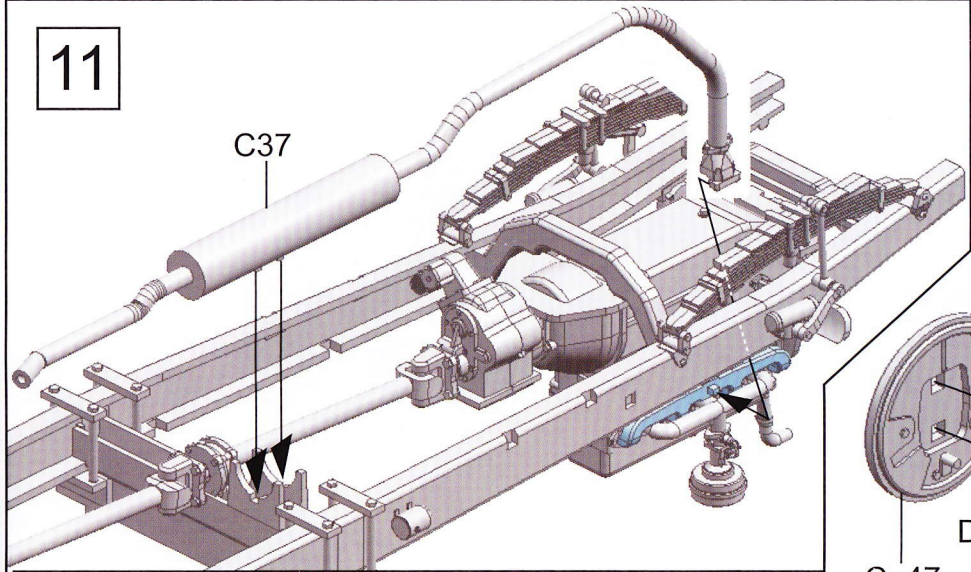
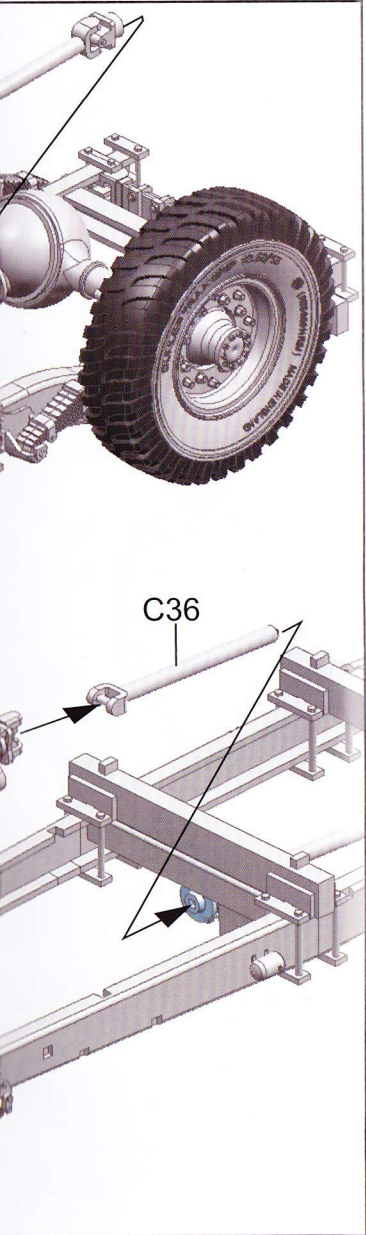



13

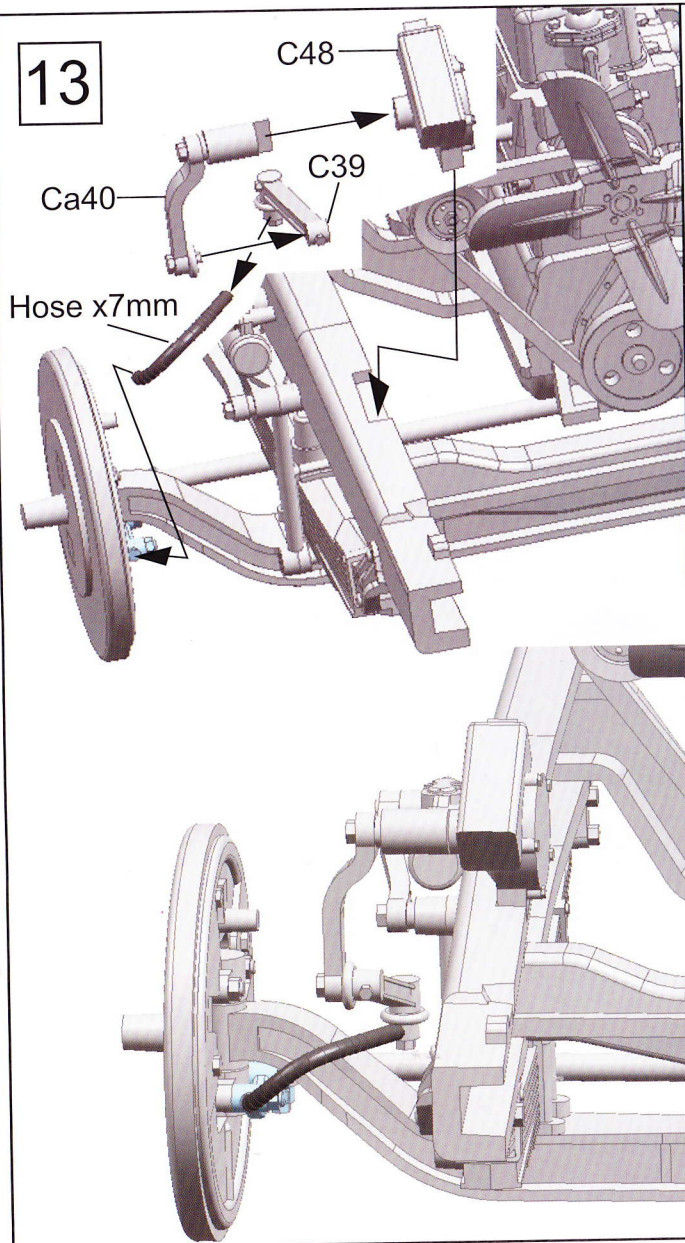

14

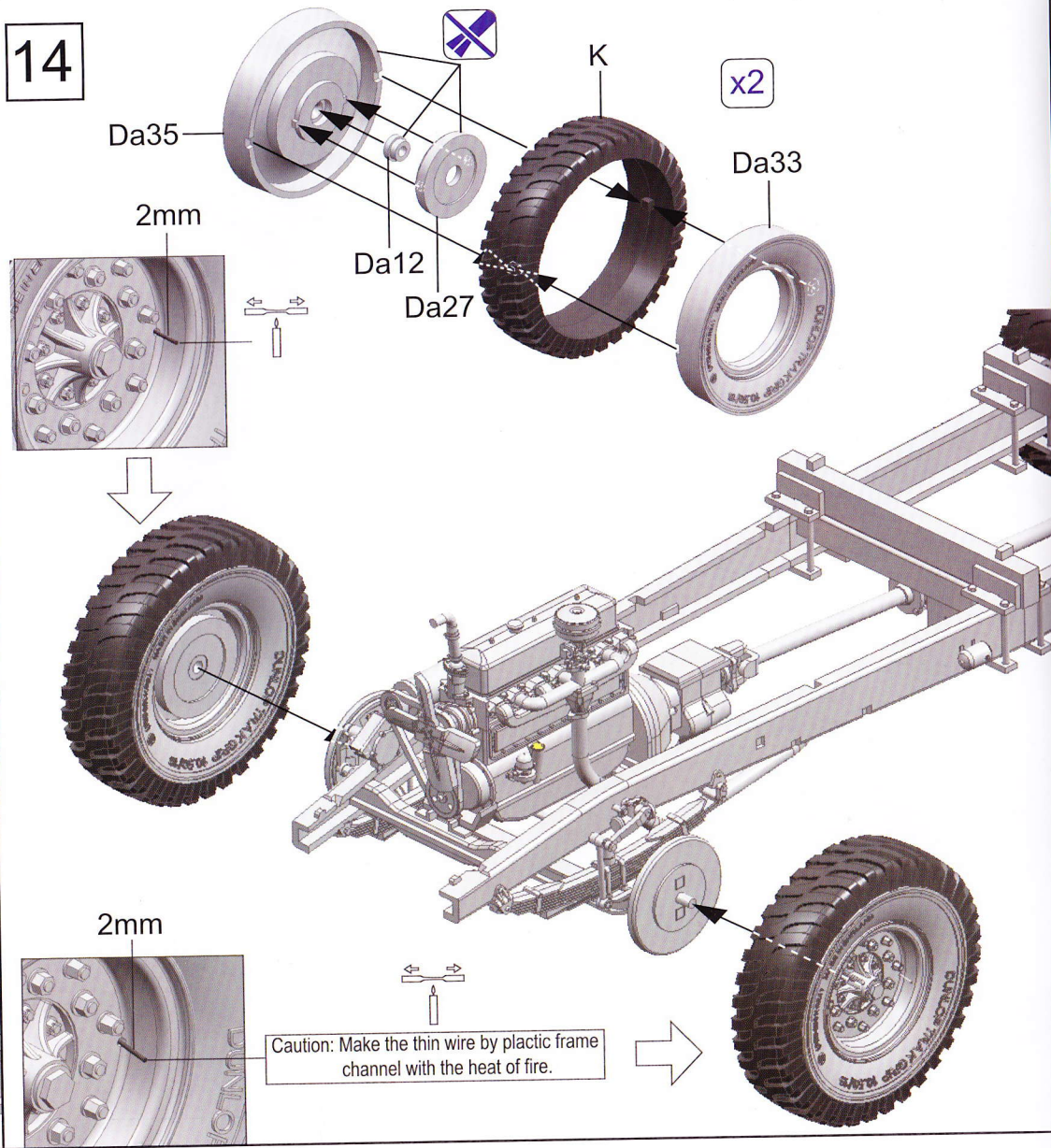

10

15

Wheels direction to left

16

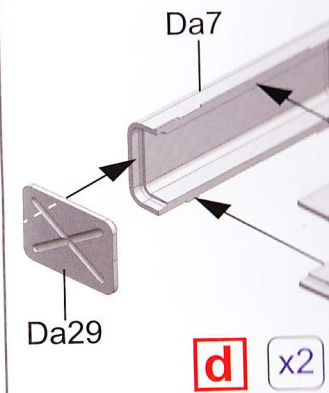

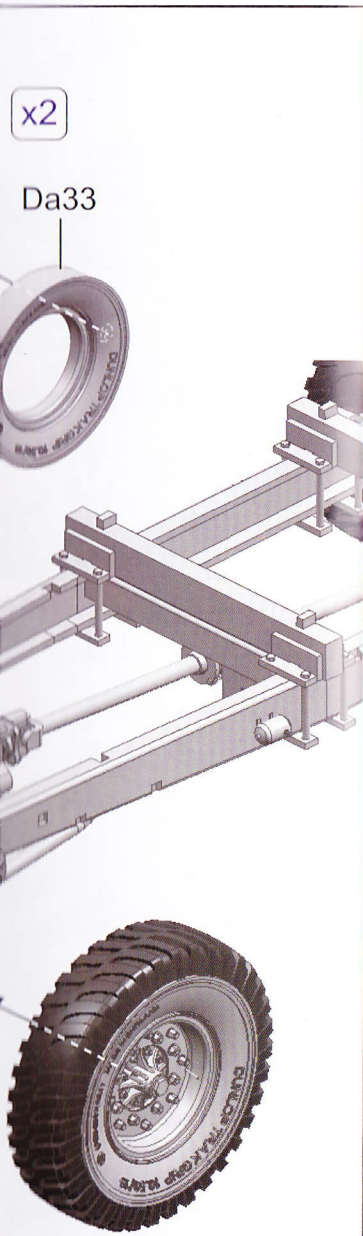

15

Wheels direction to left

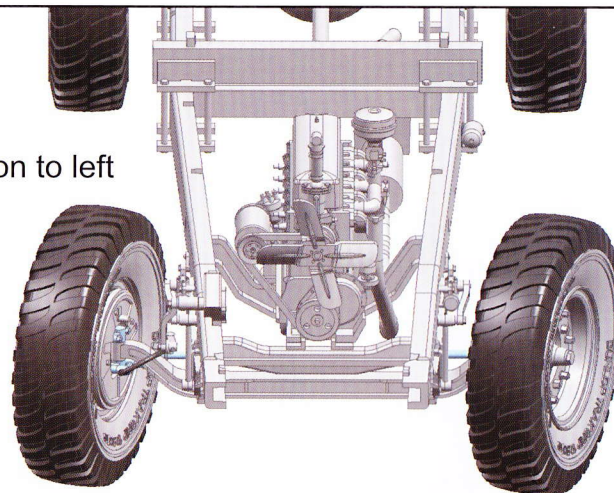

Wheels direction to right

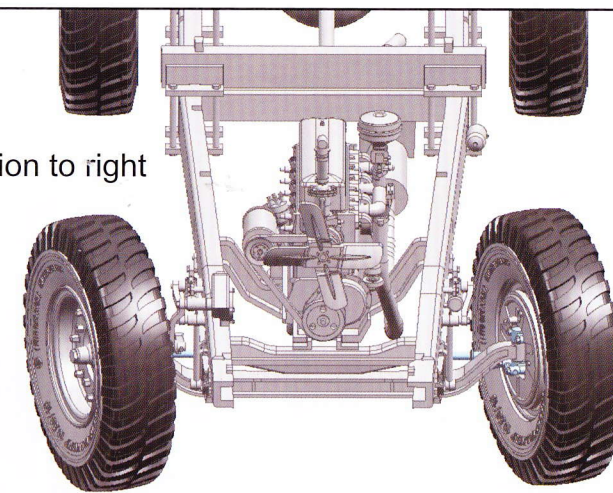

16

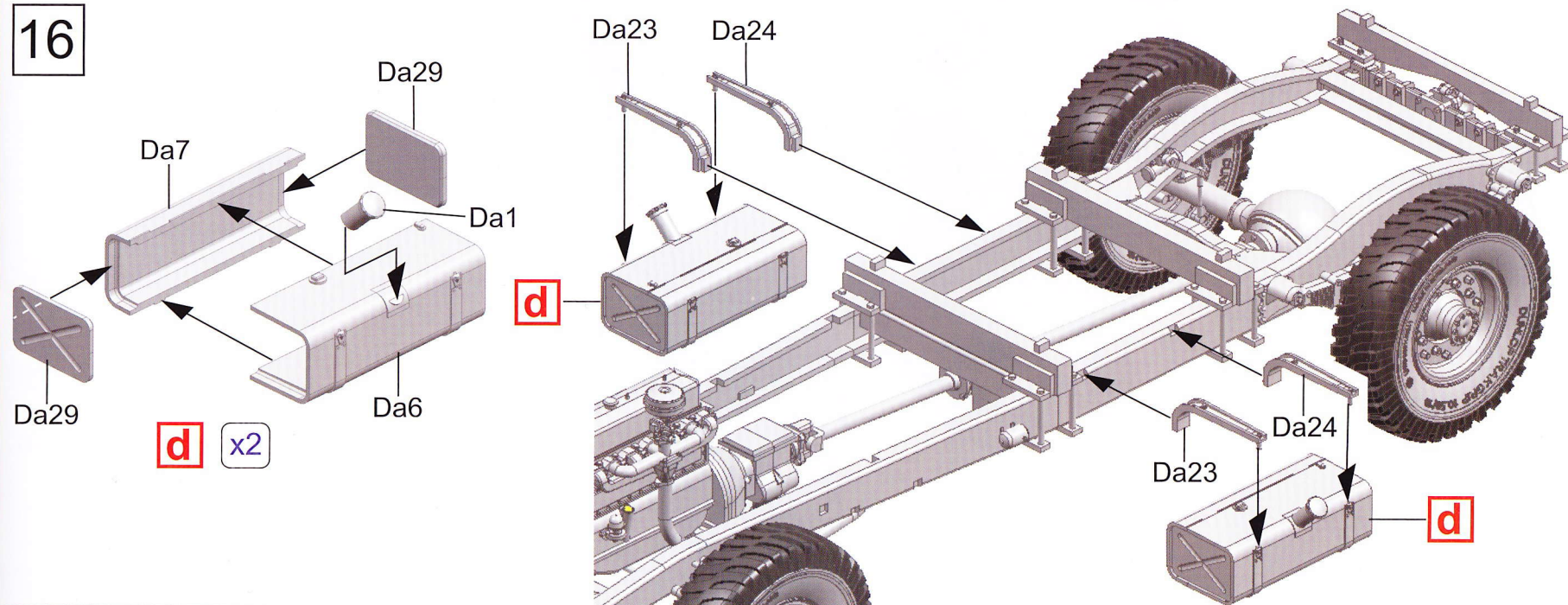

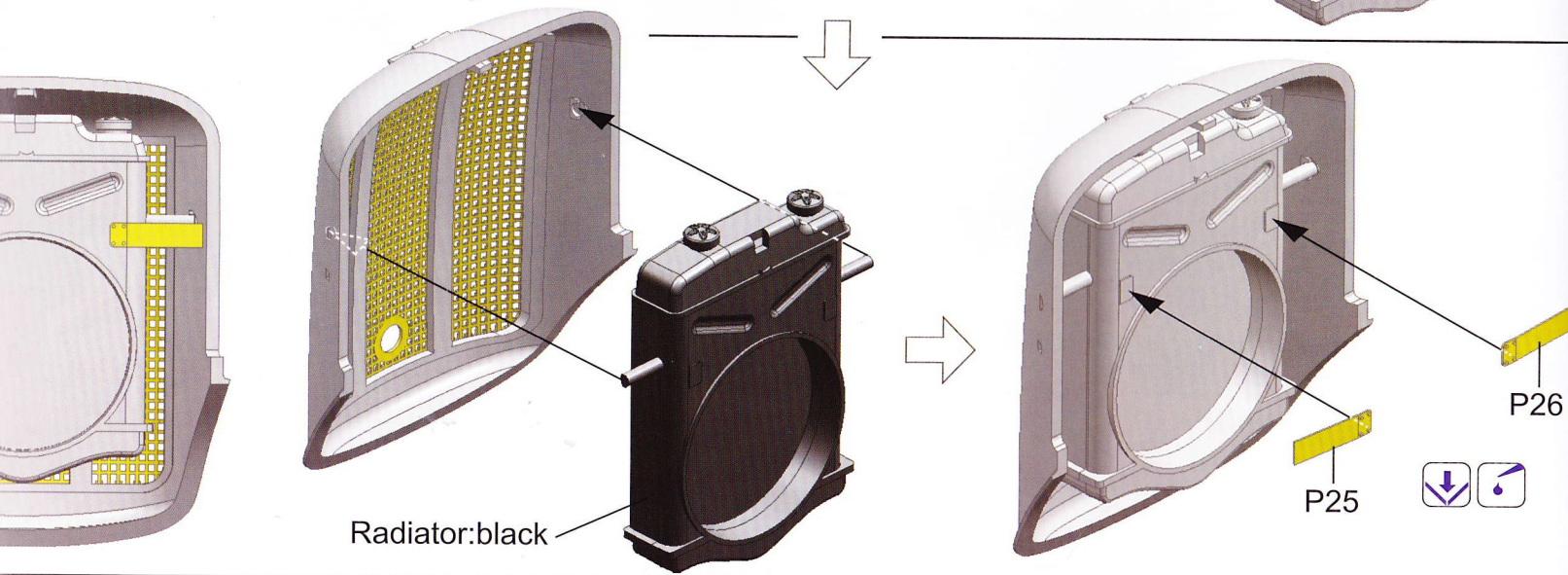
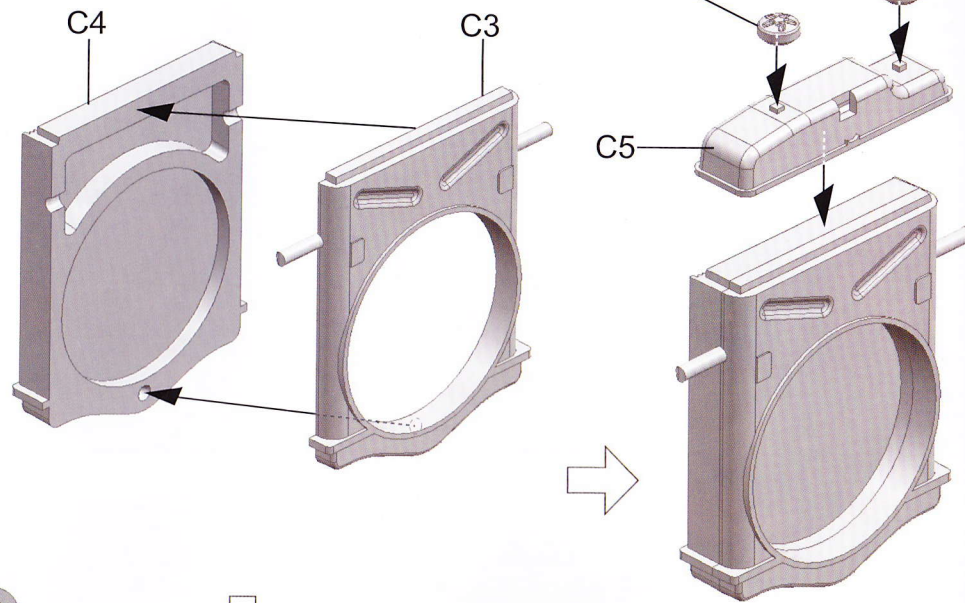
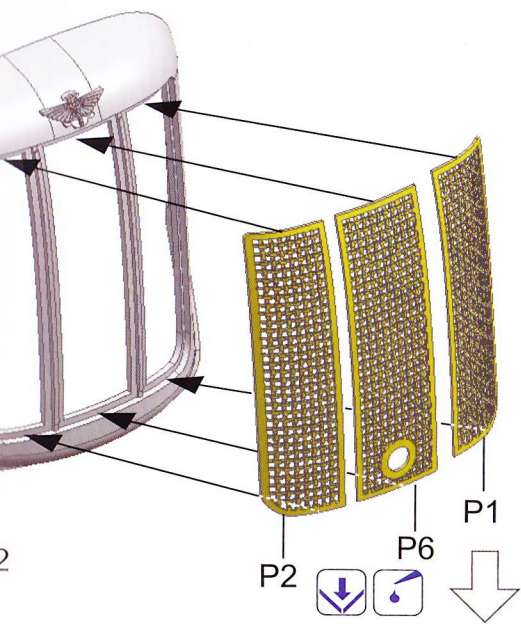

18

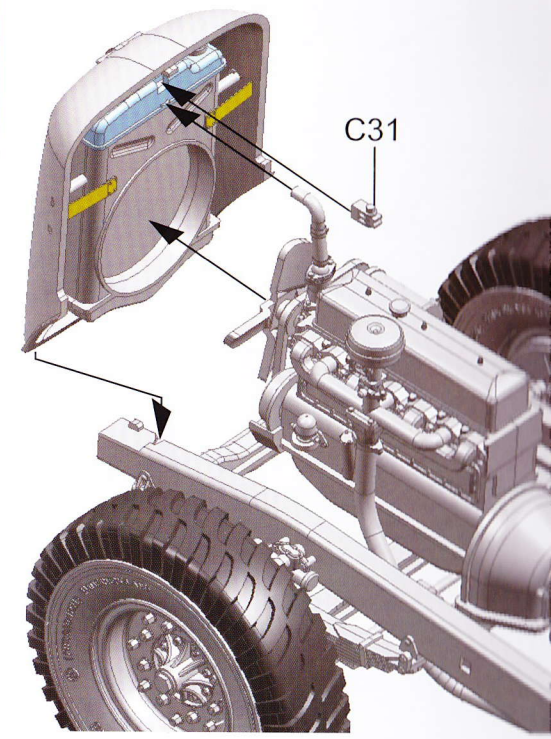

12

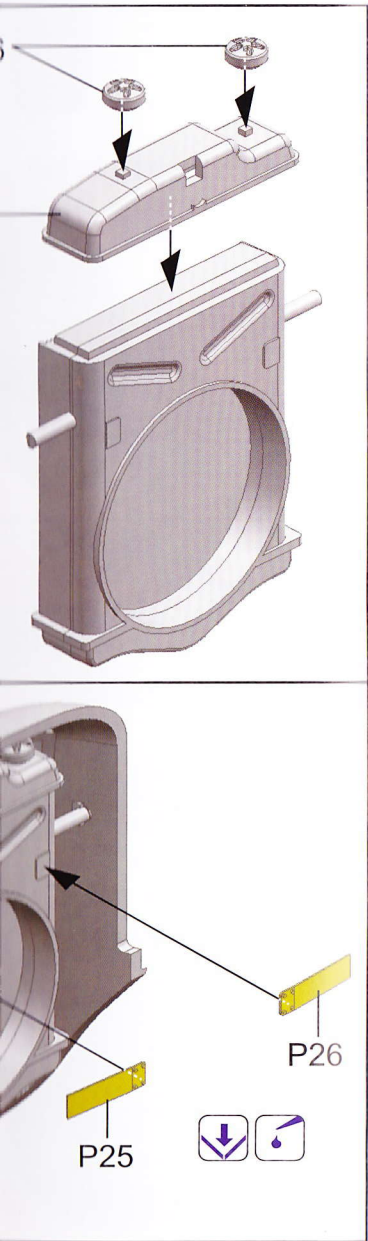

18

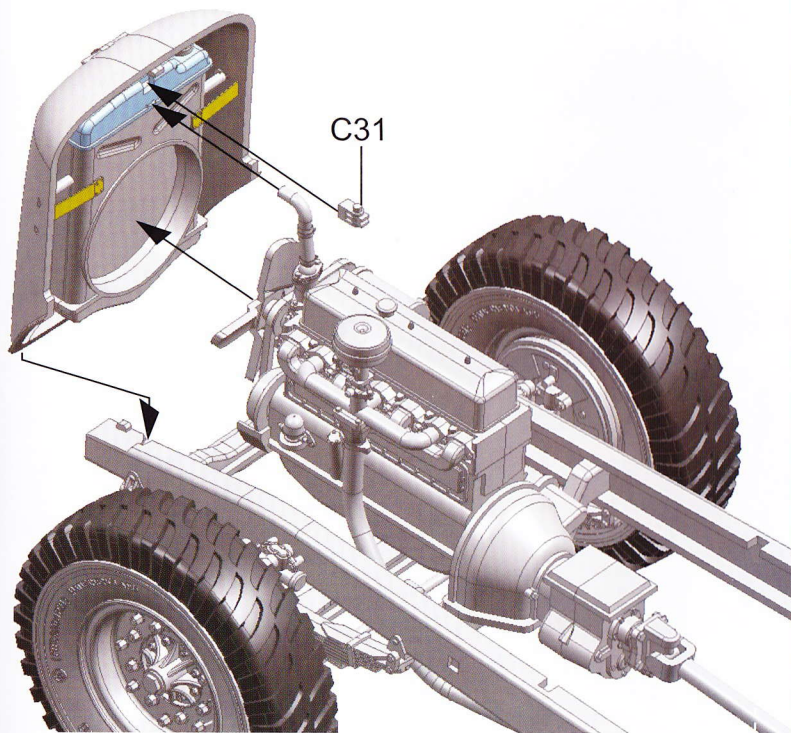

19

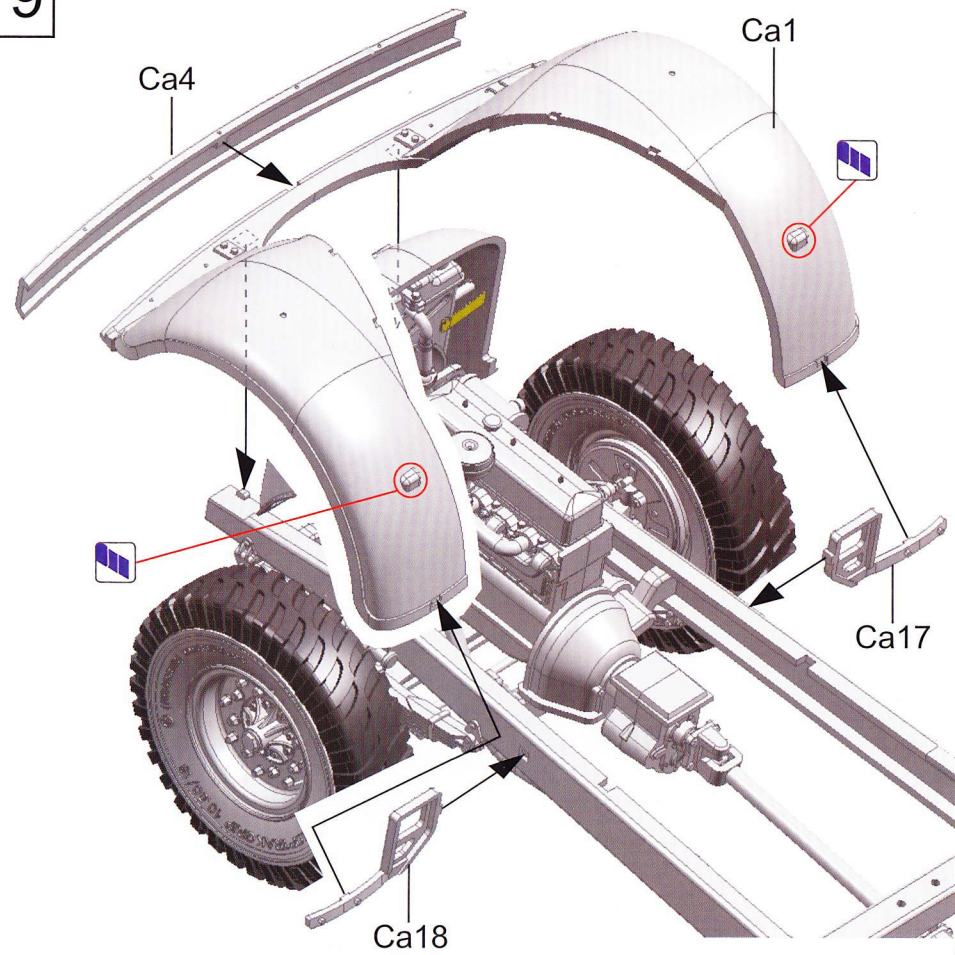

20

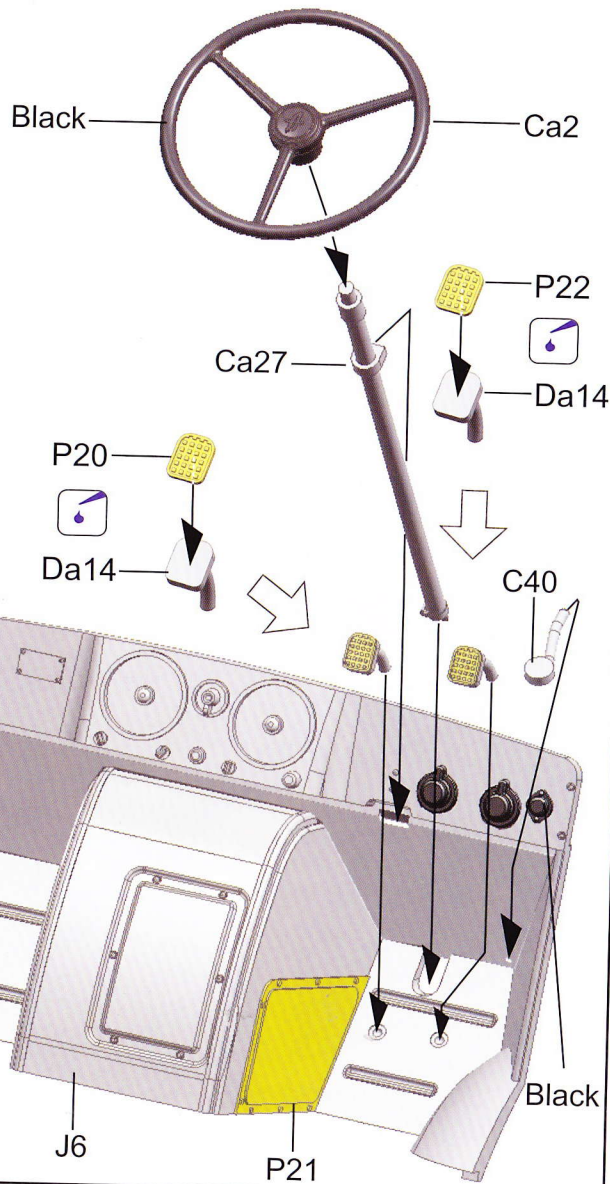

21

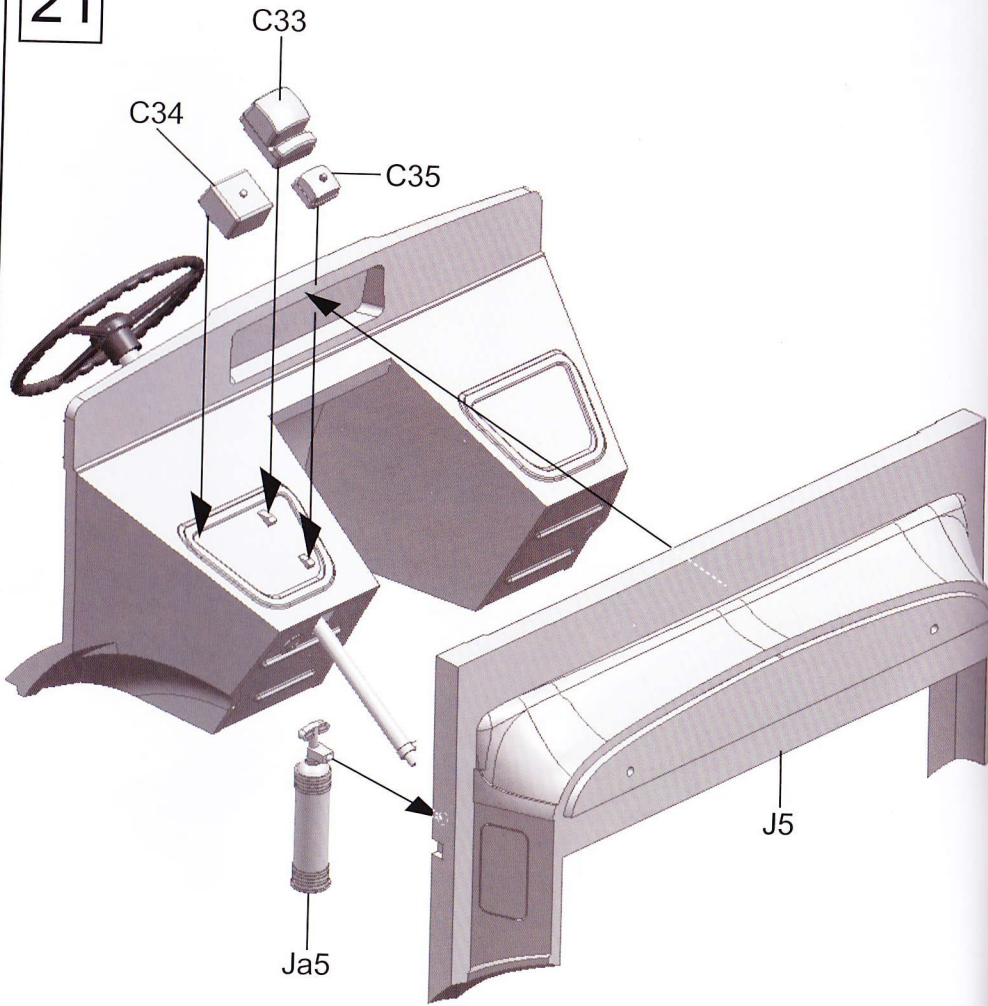

22

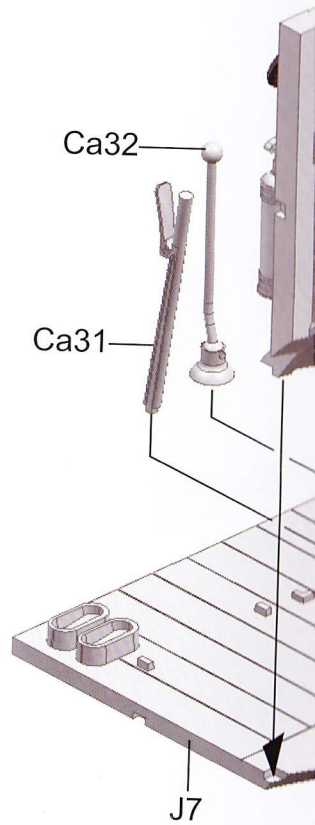

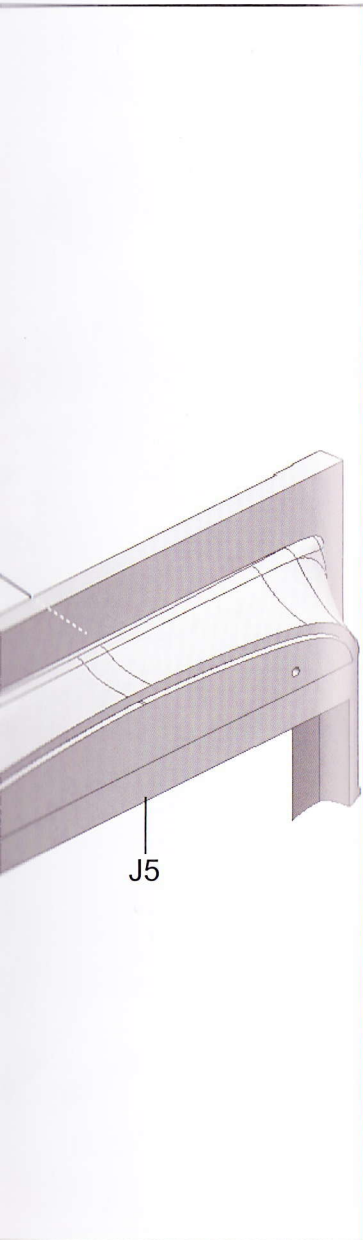

22

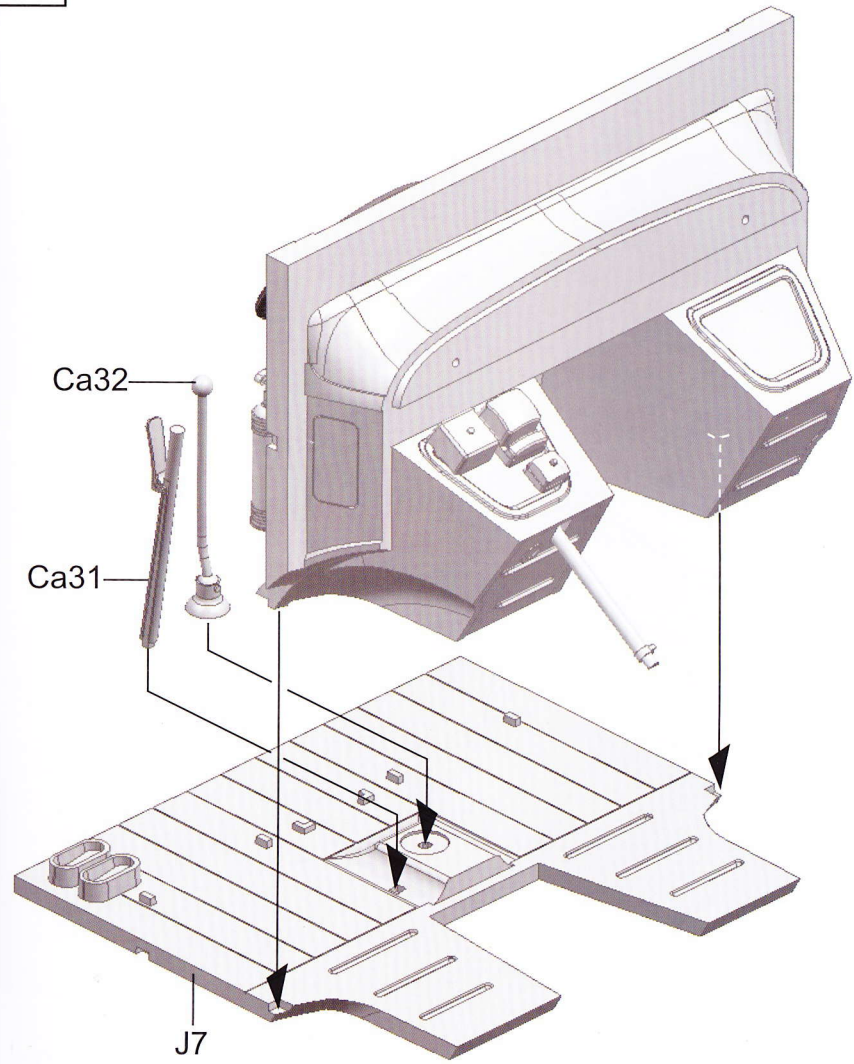

23

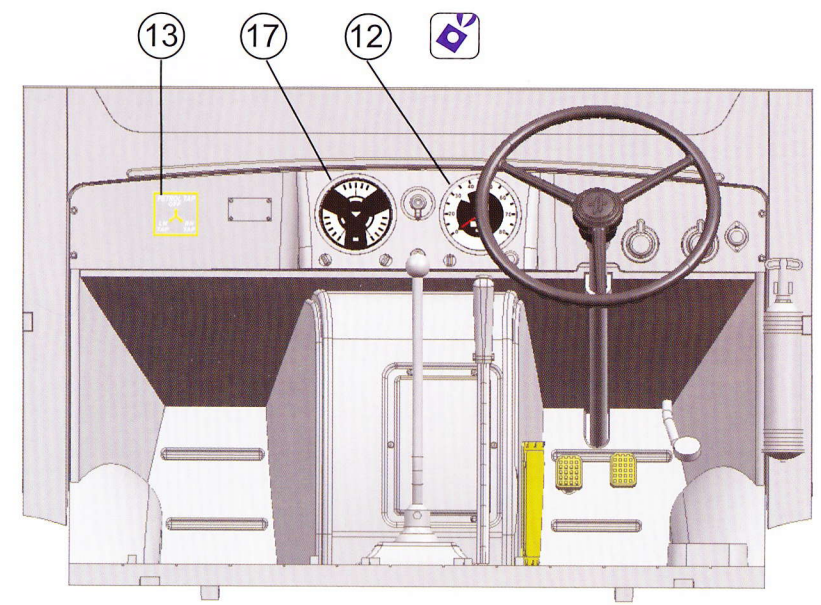

24

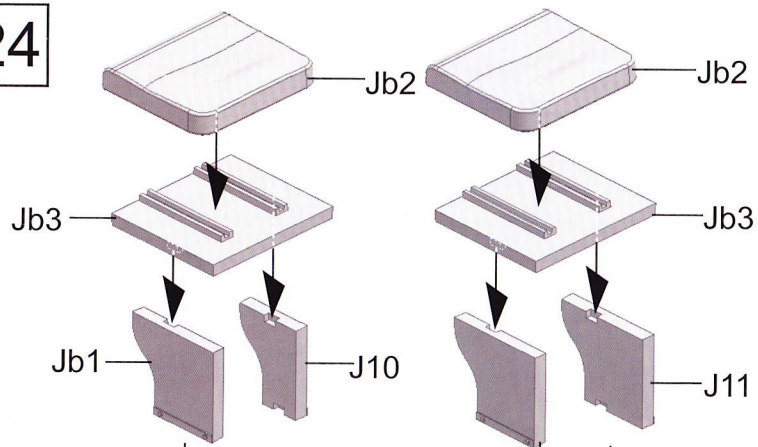

25

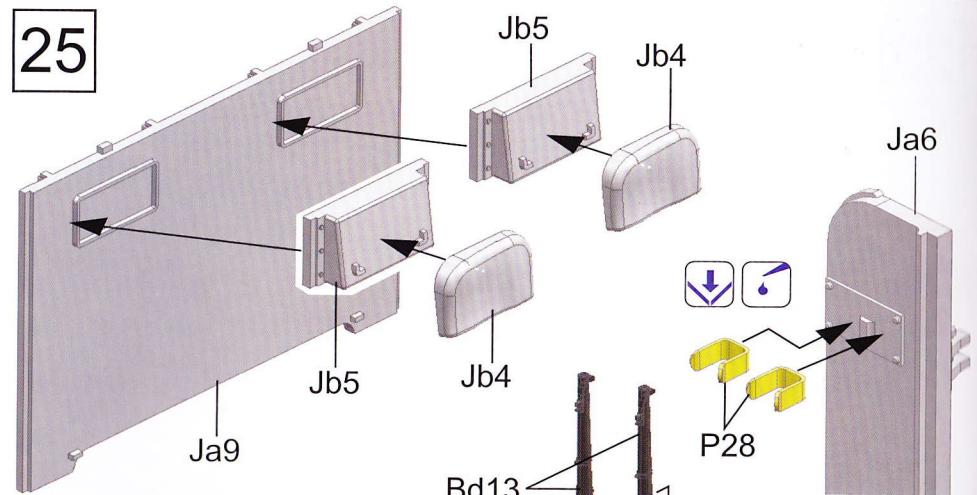

26

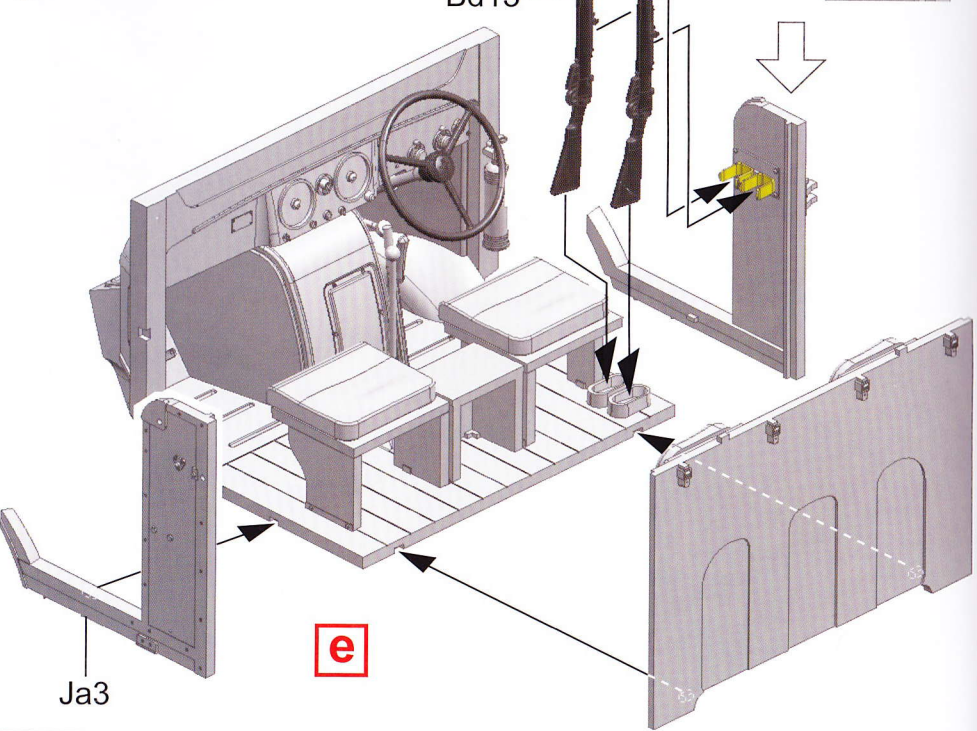
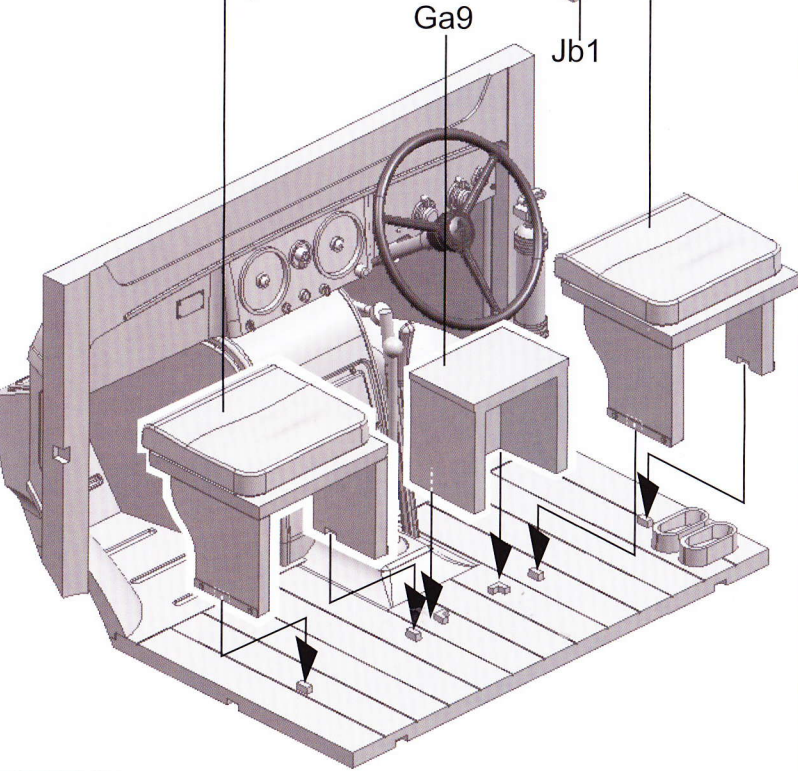
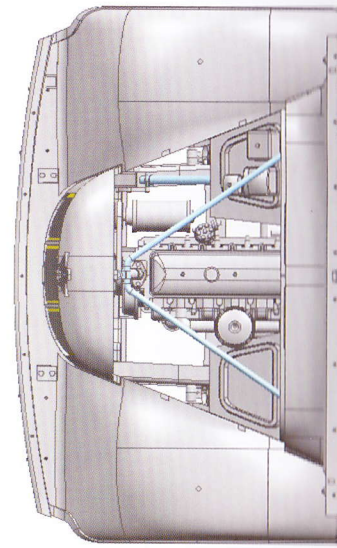
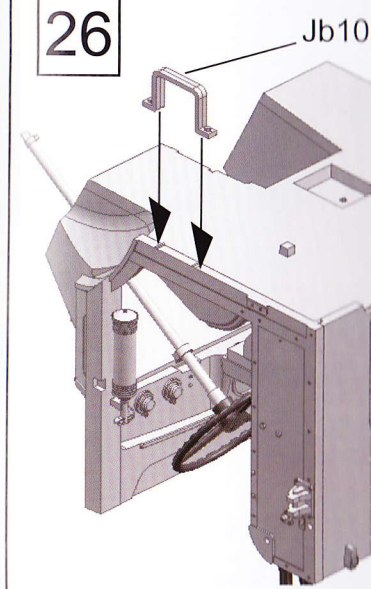

e

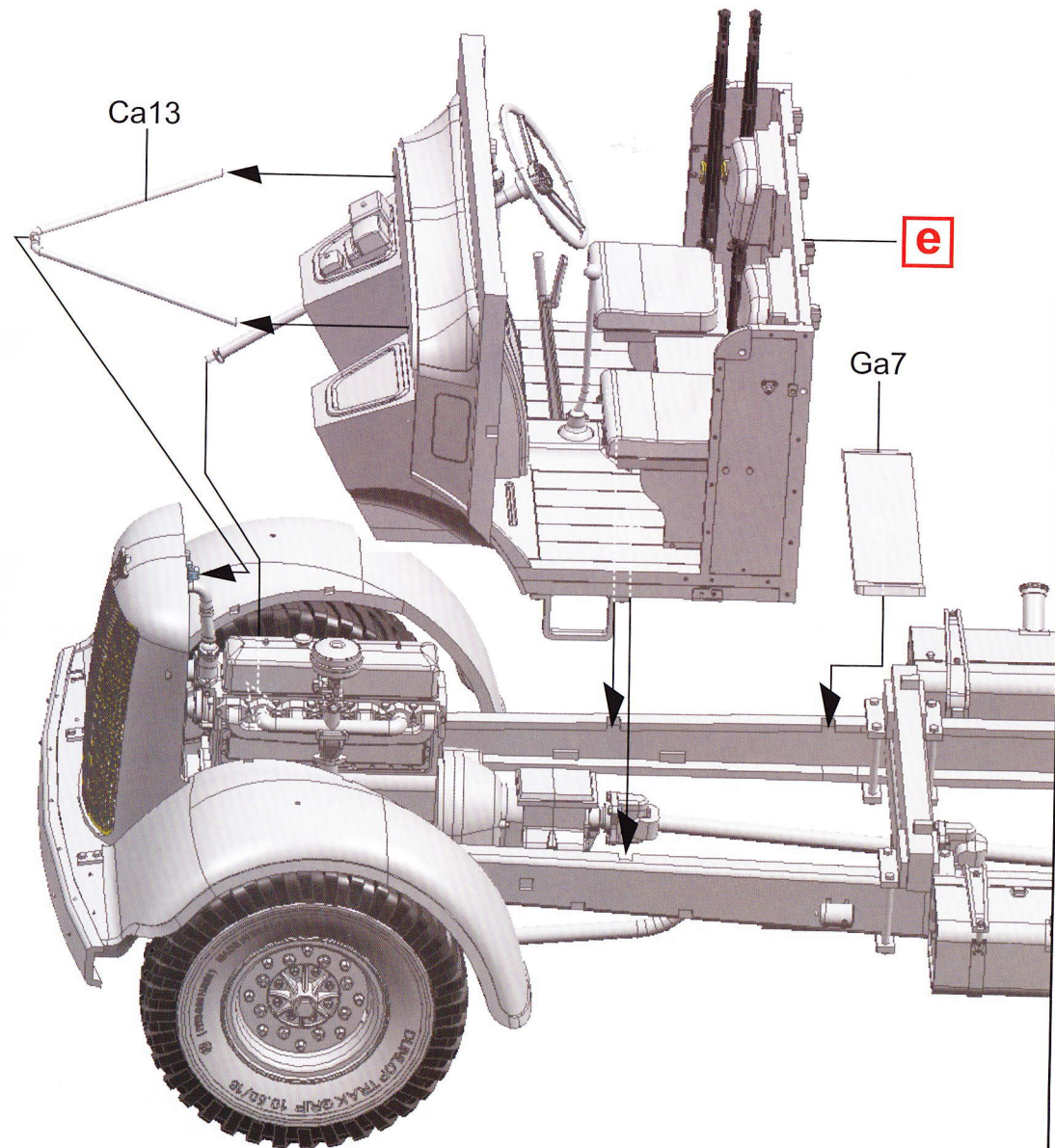
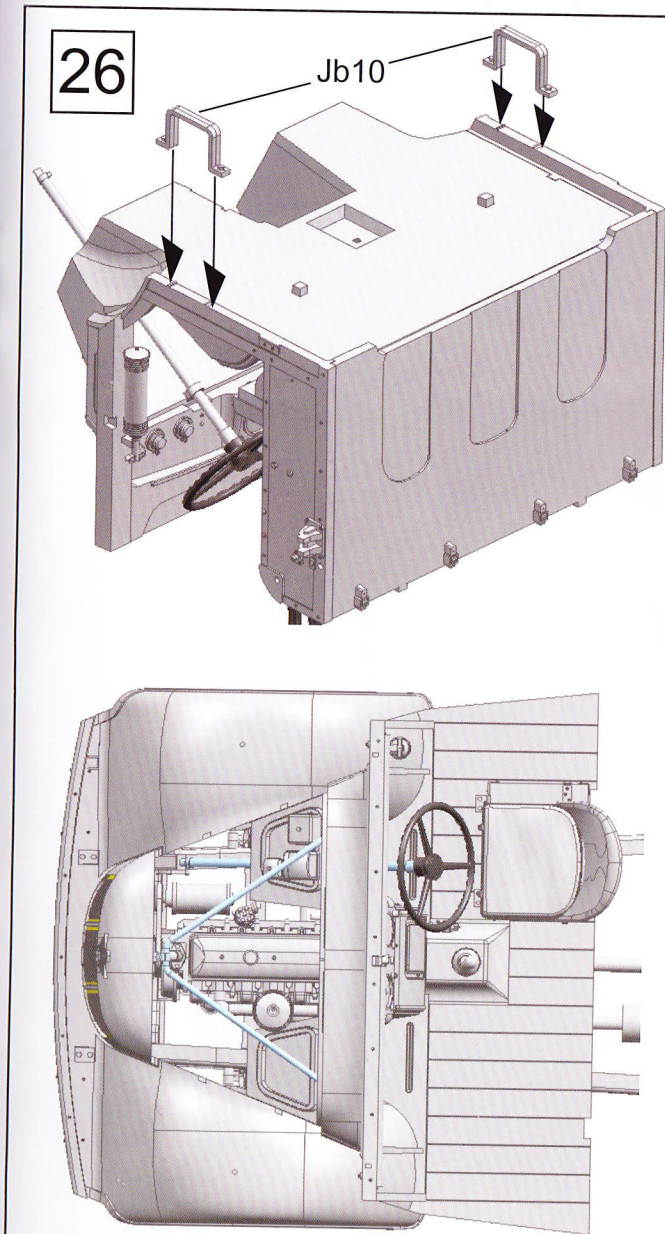
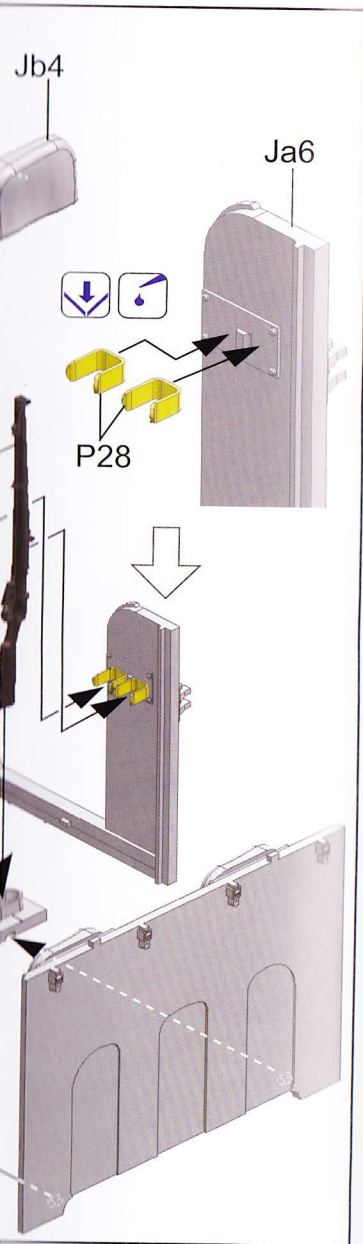



27

Left

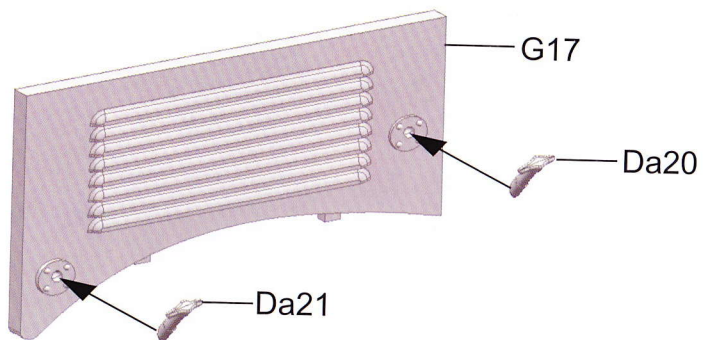

Right

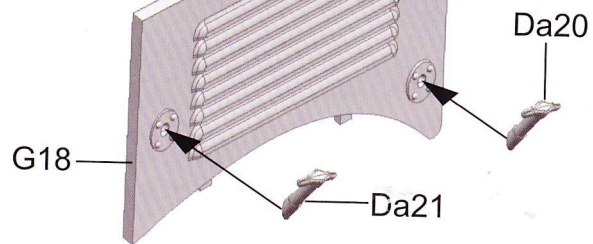

28

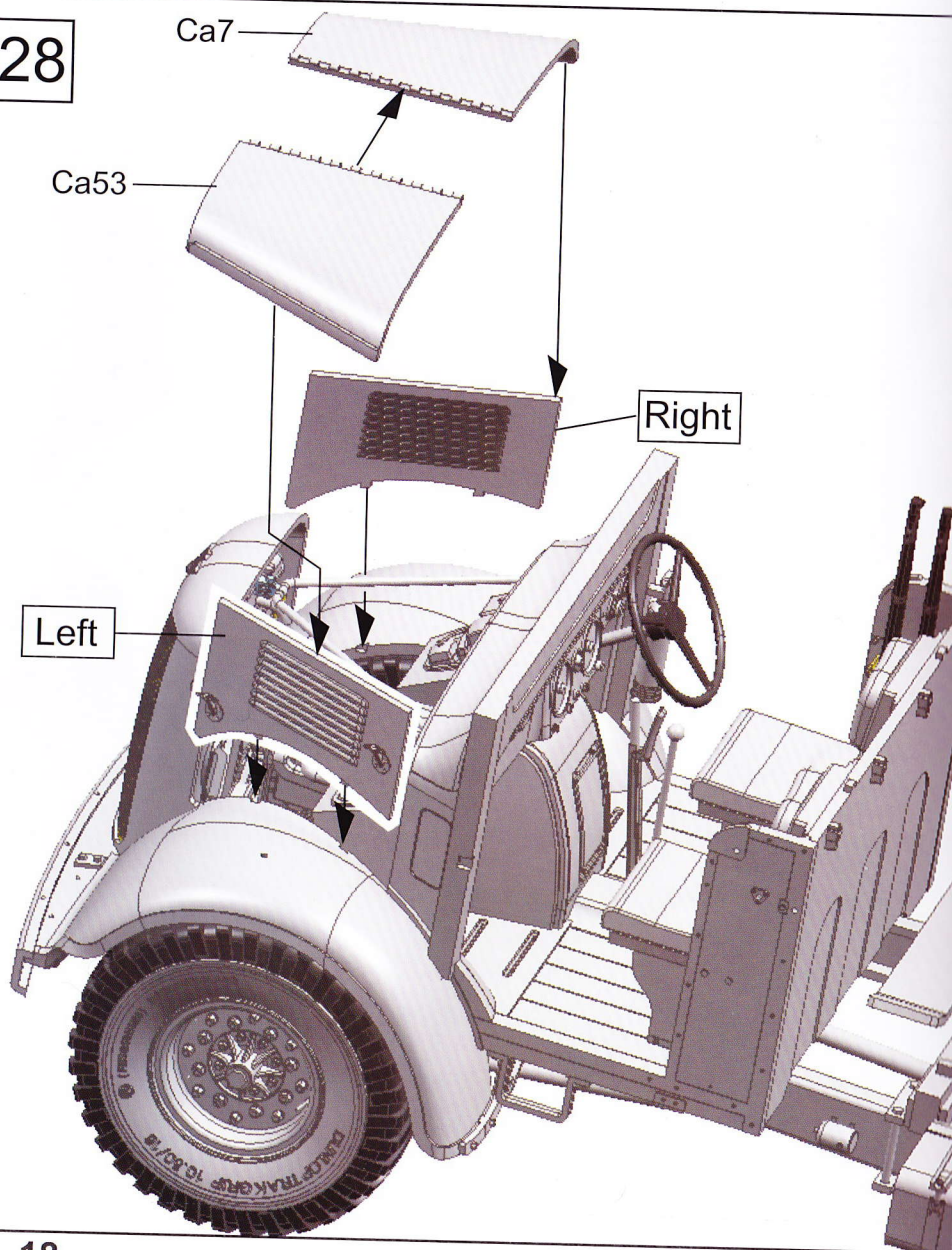

29

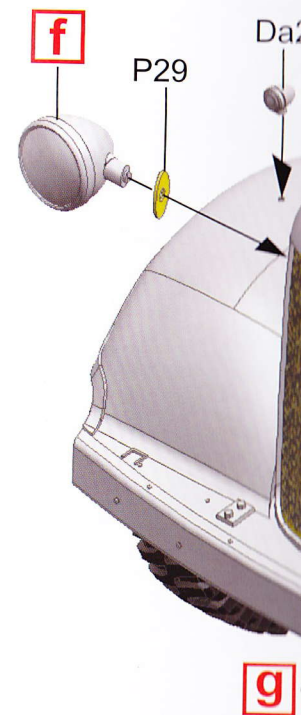
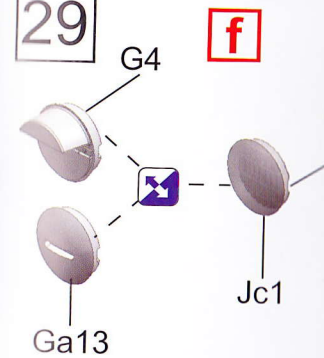

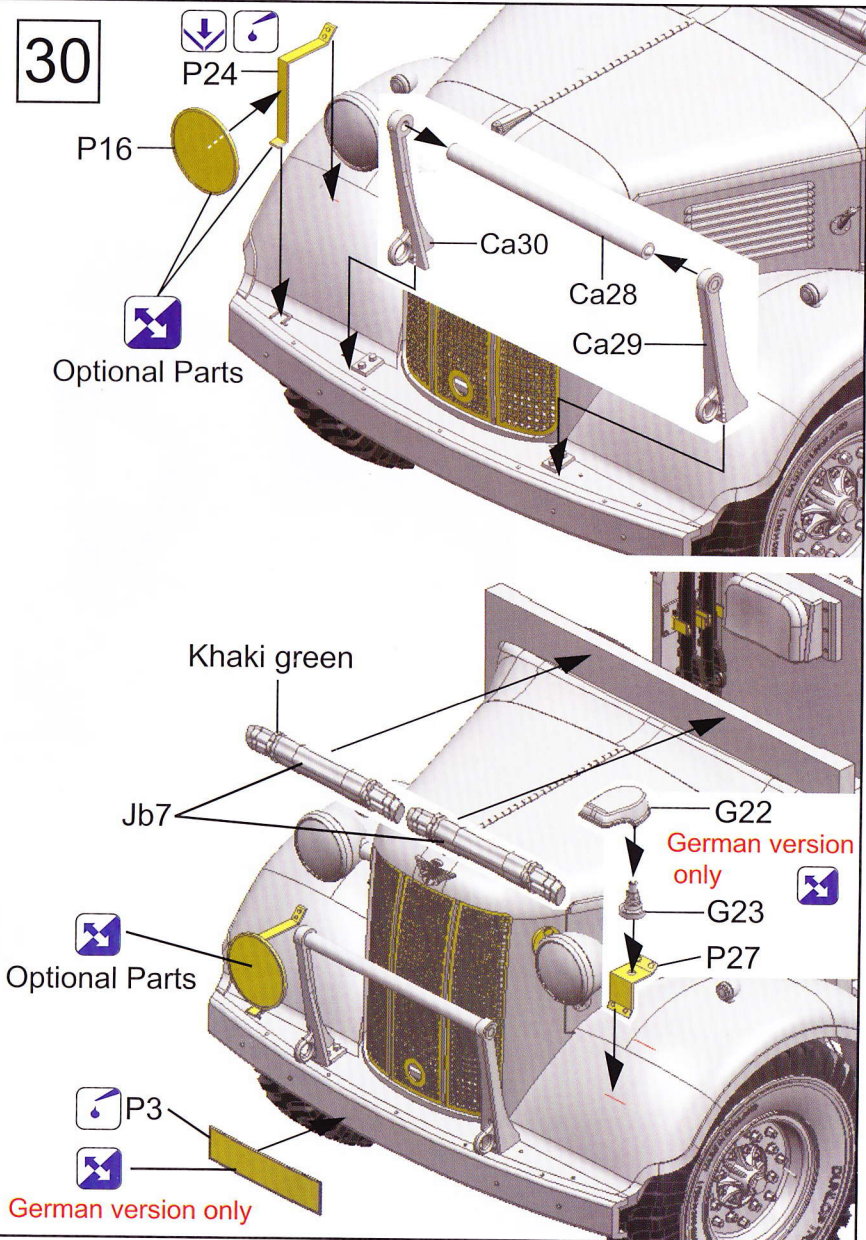
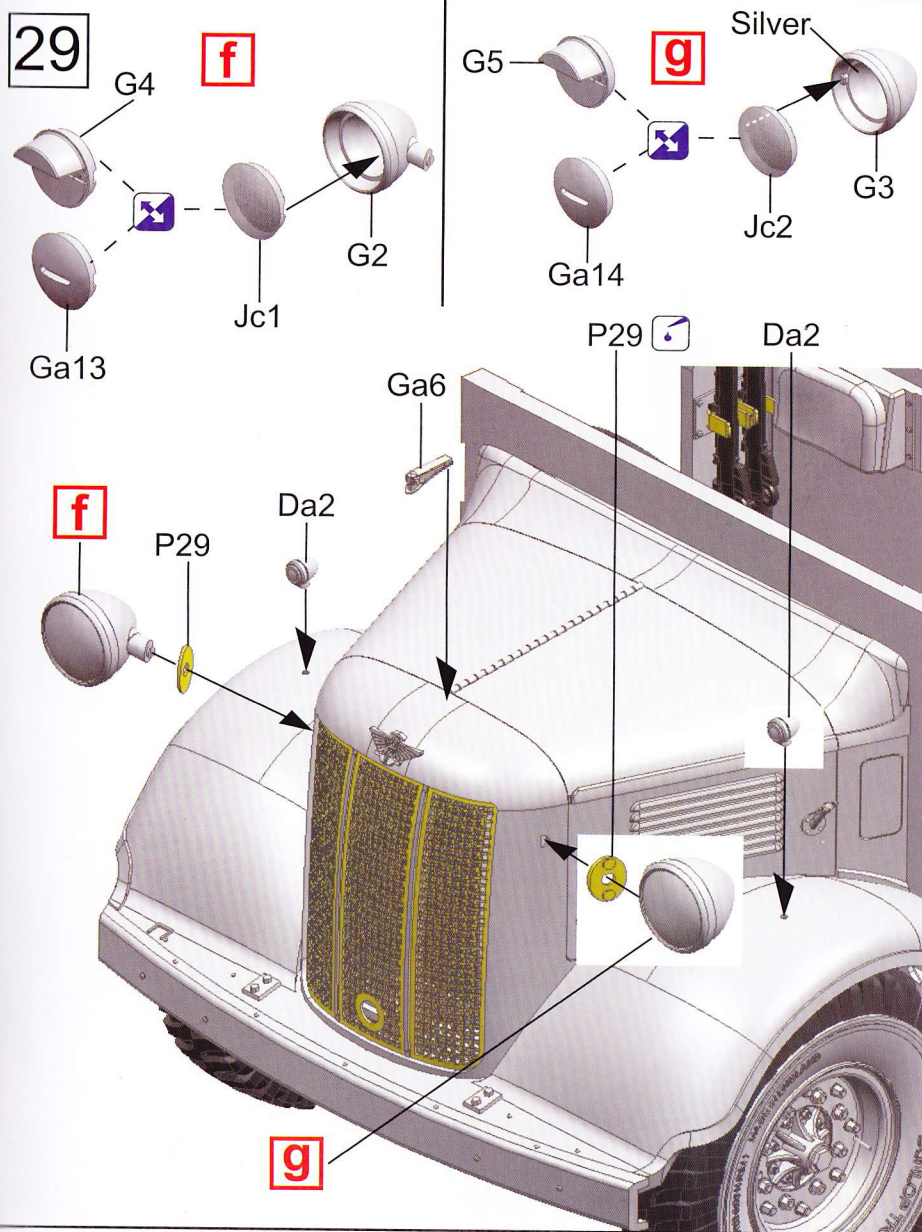
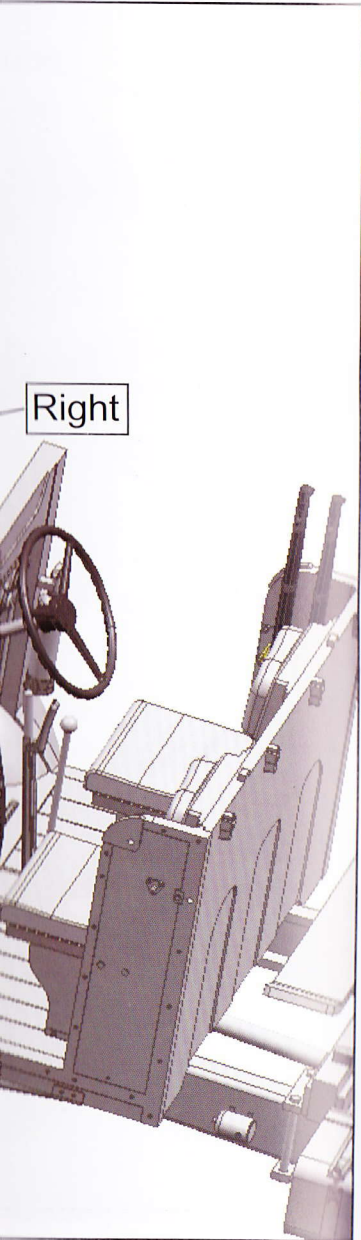

31 Type A:

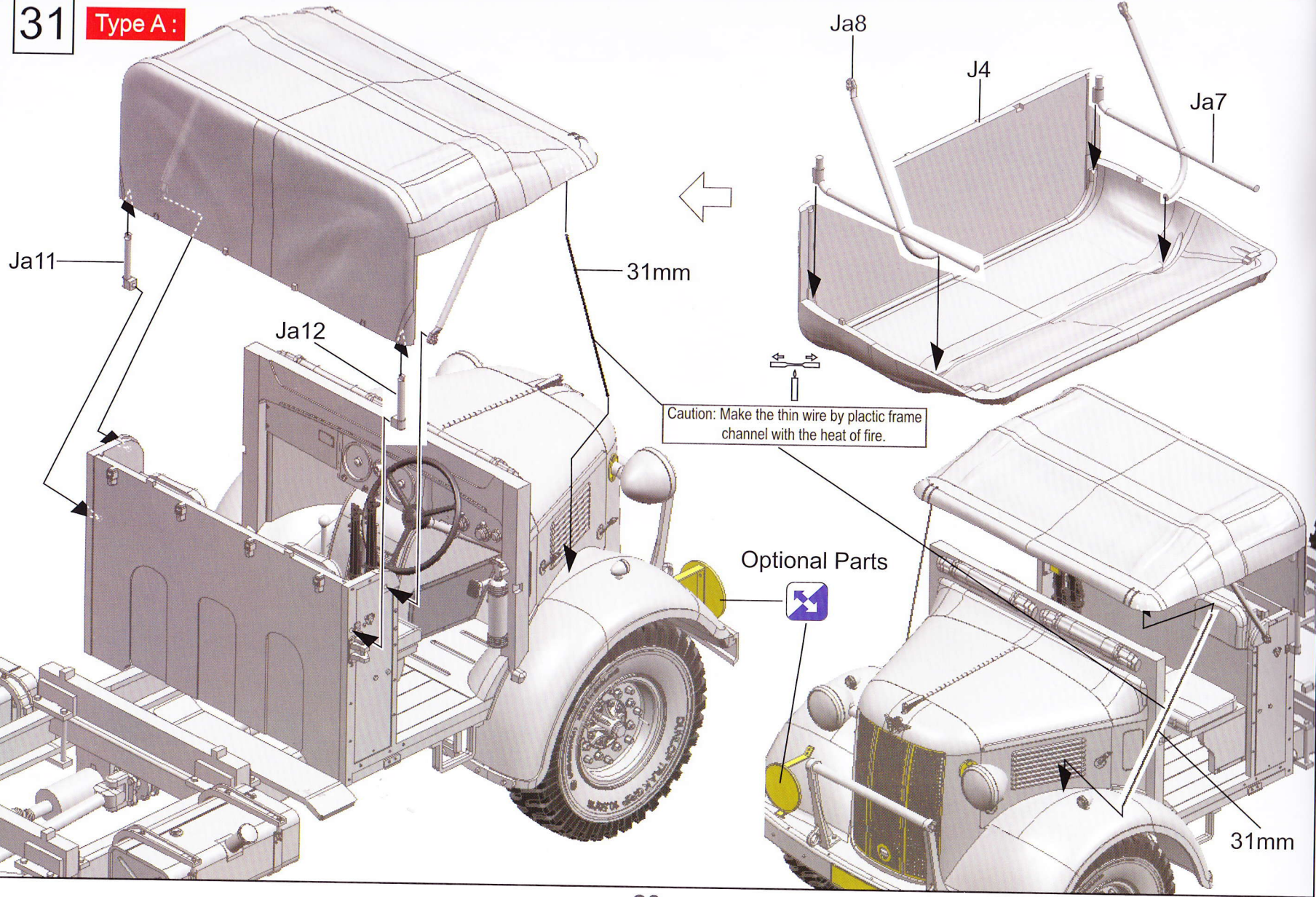

32 Type A:

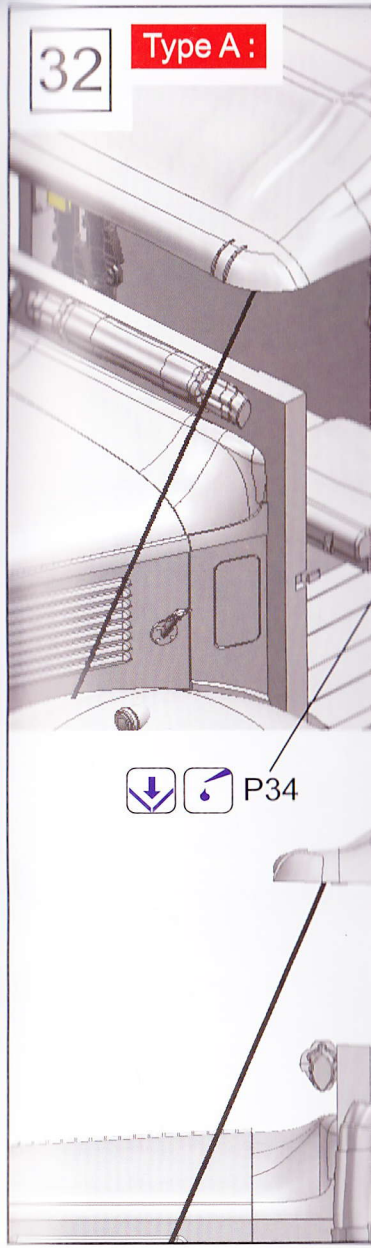

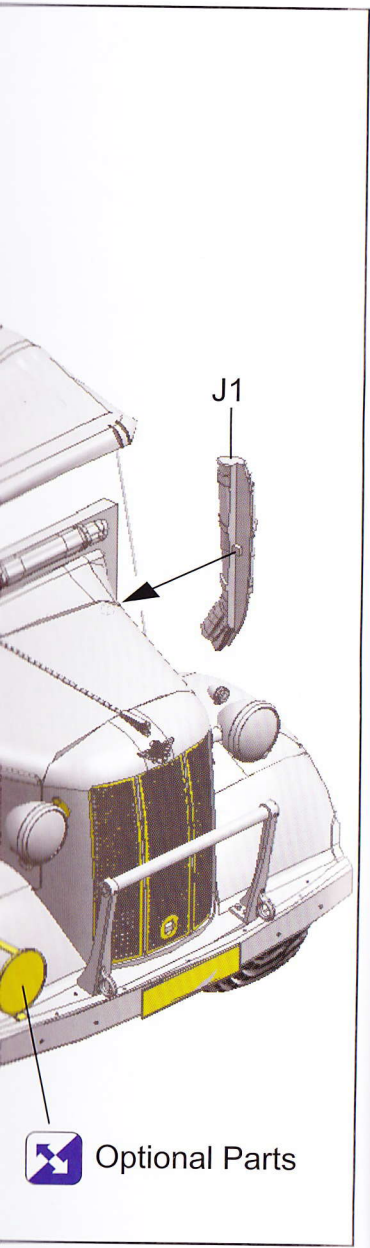

34

Type B :

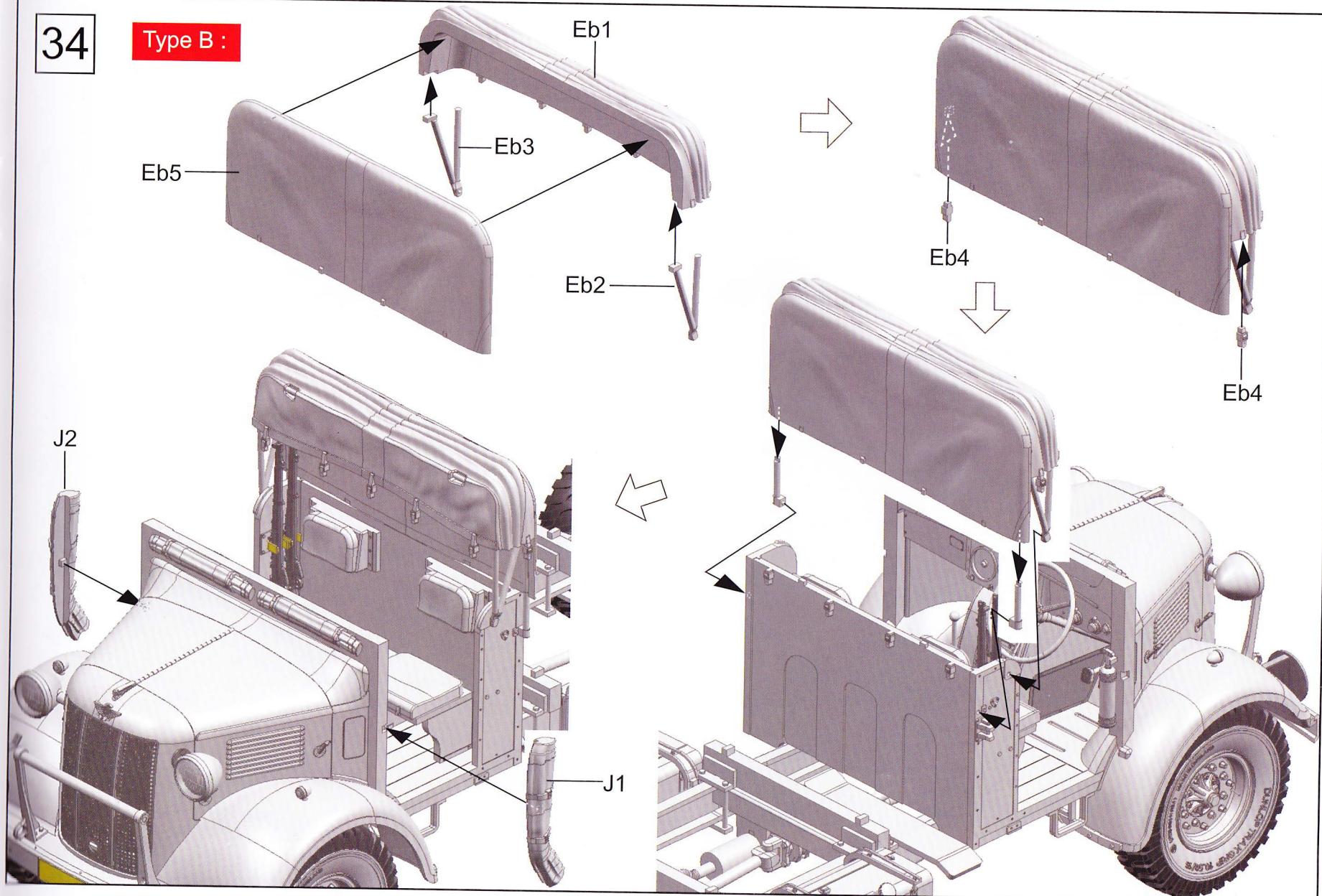

35

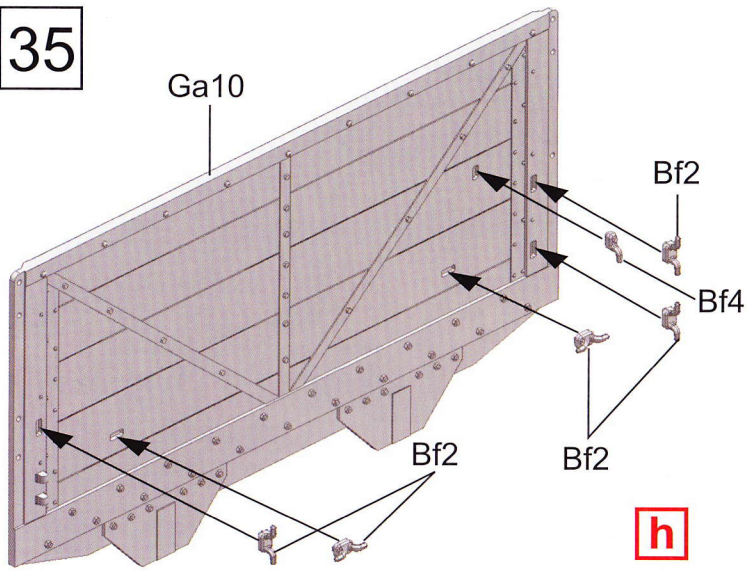

h

i

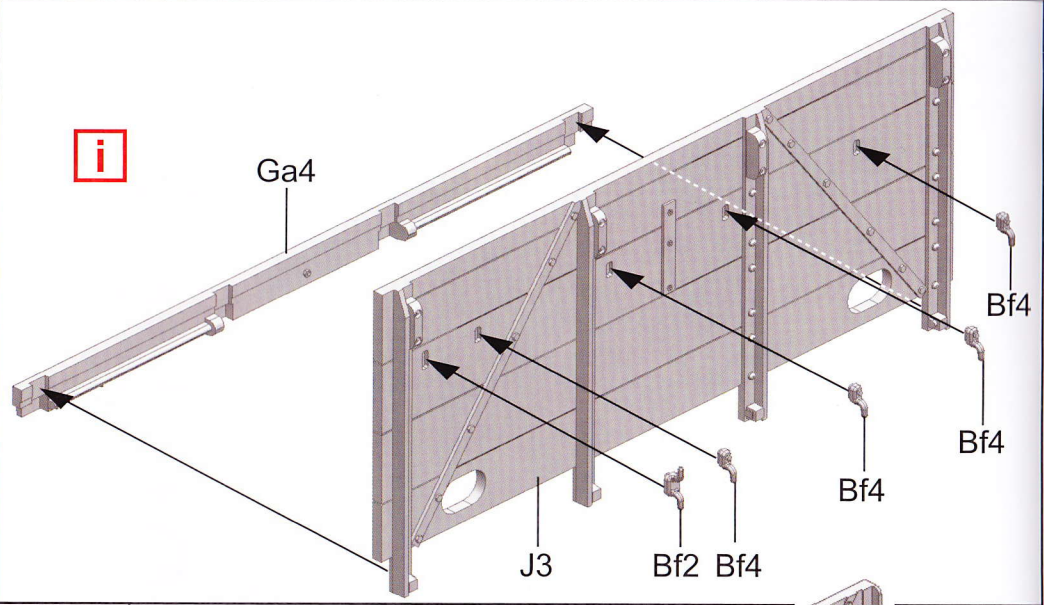

x24

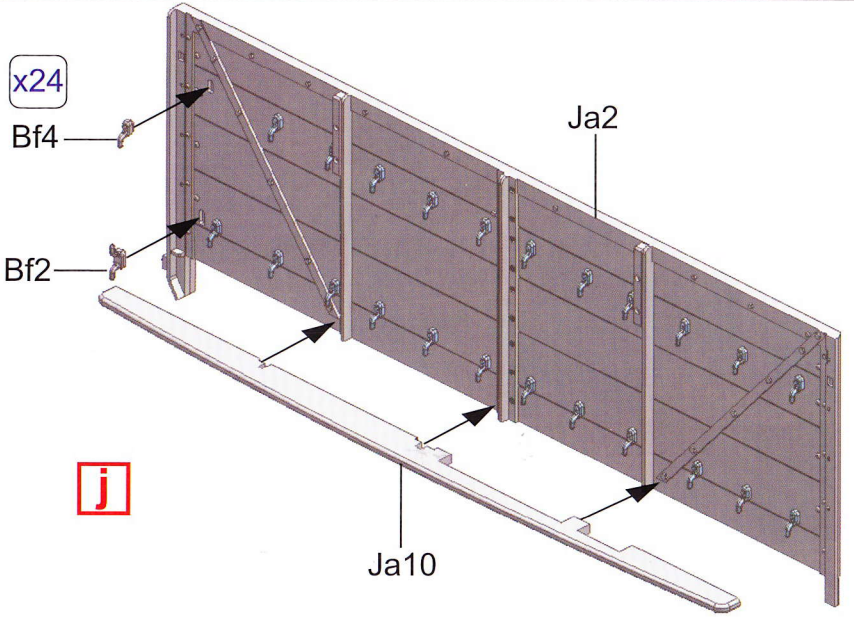

j

Ja1

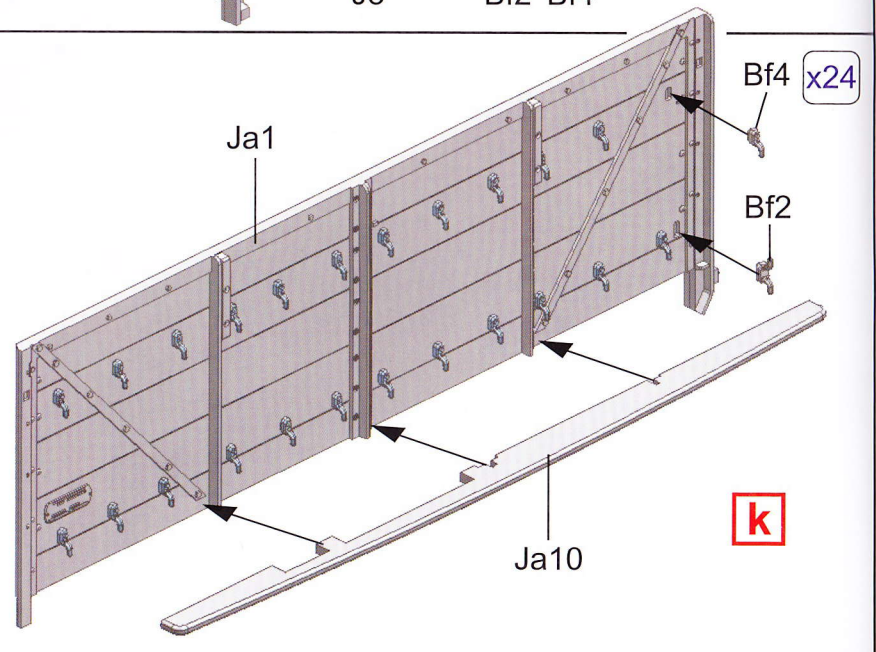

k

36

Option 1 :



k

\* Please pay attention to of the platform during th

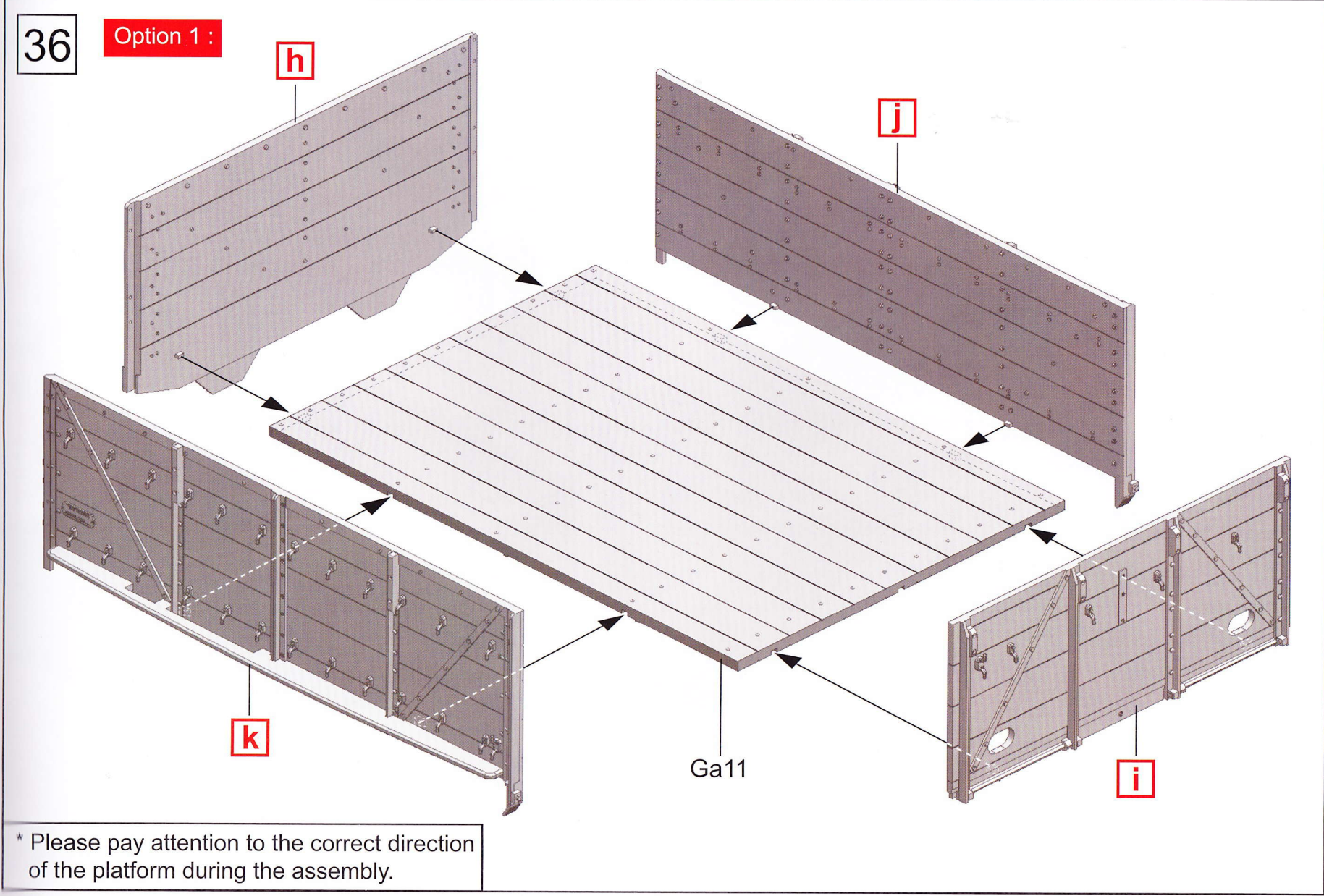
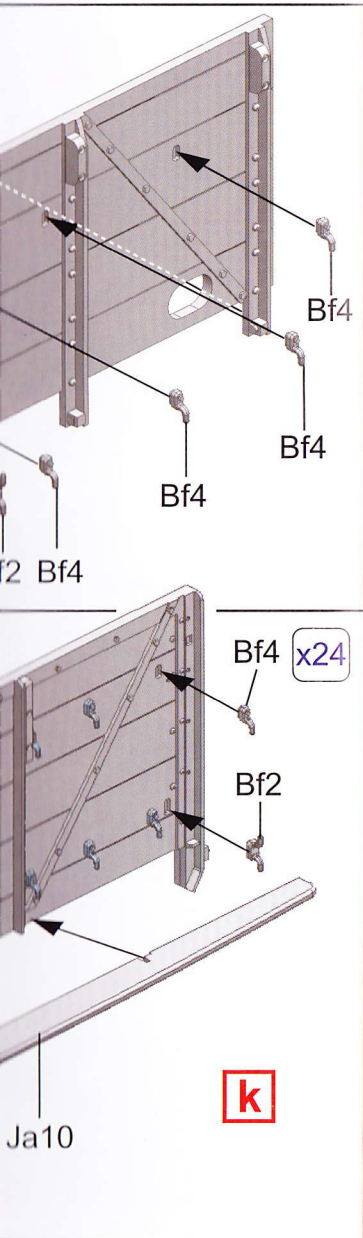

37

Option 1 :

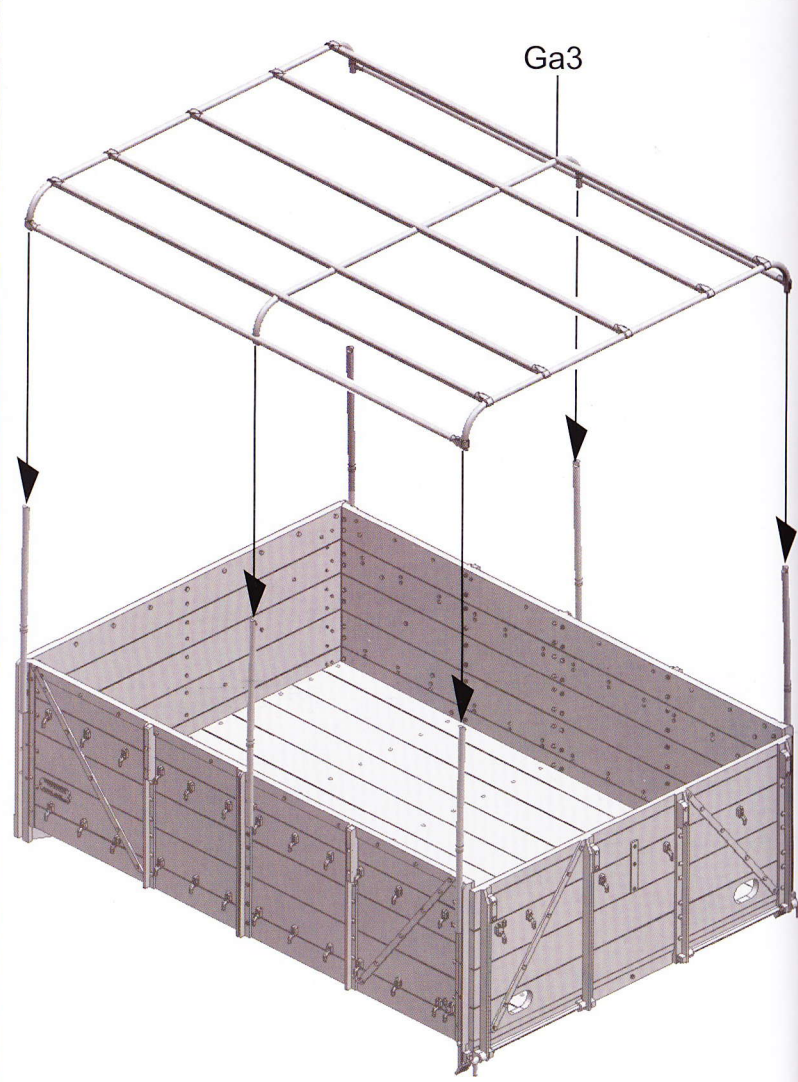
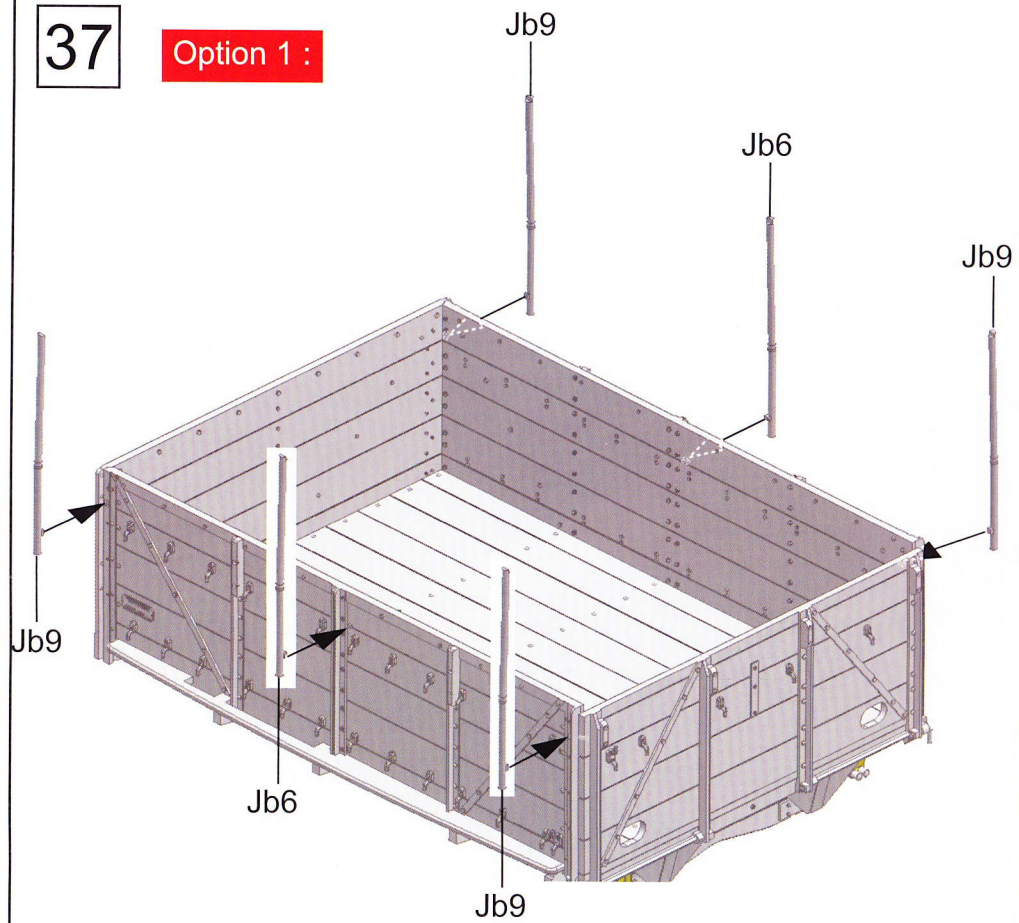

38

Option 2 :

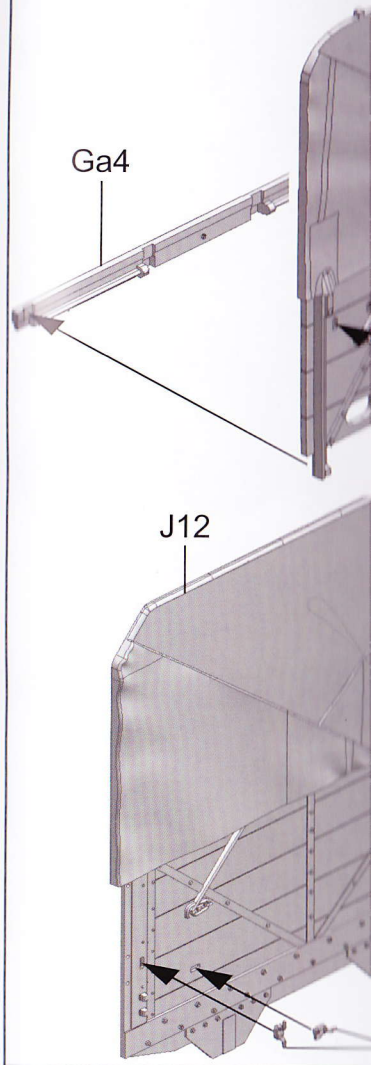

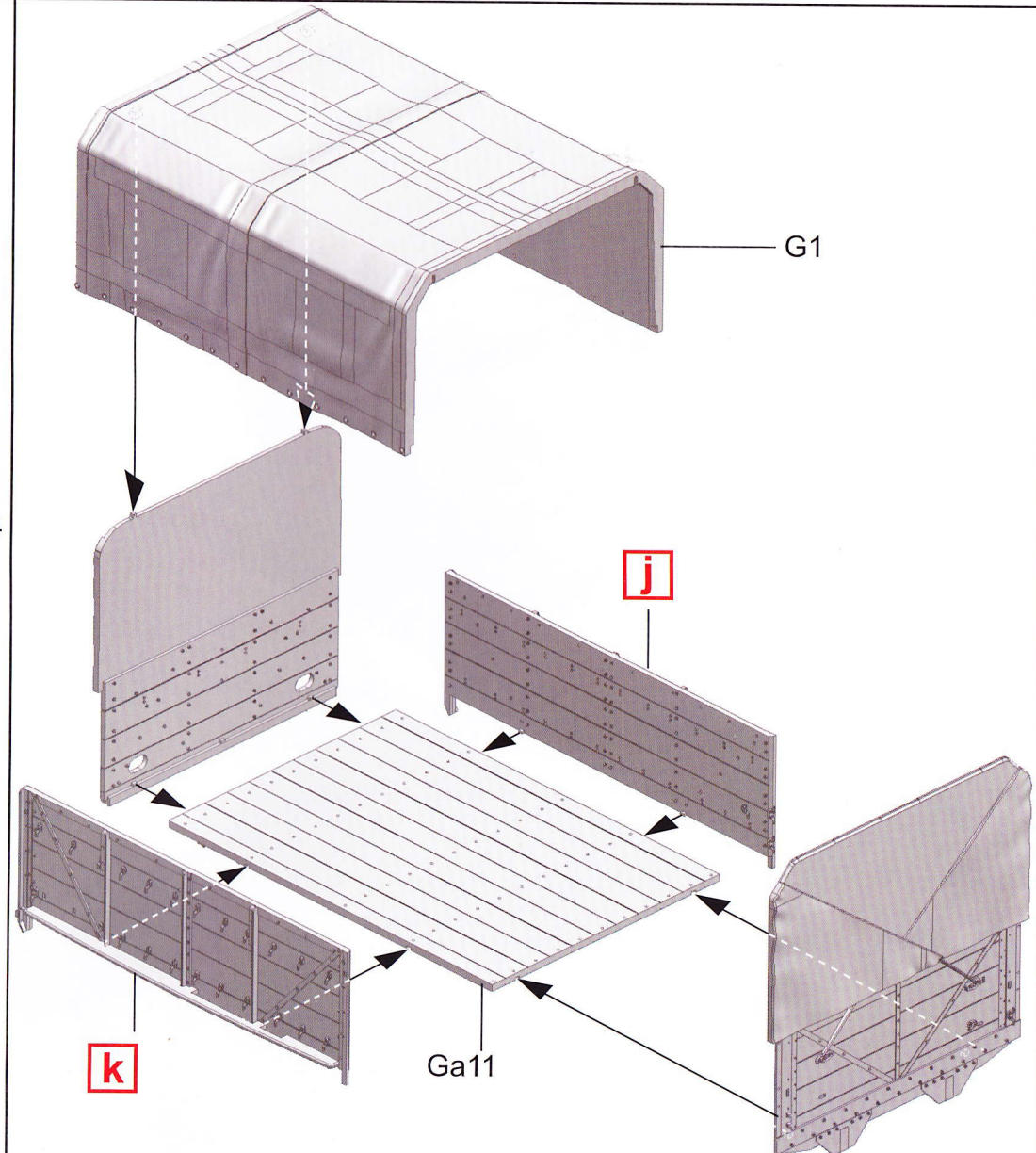
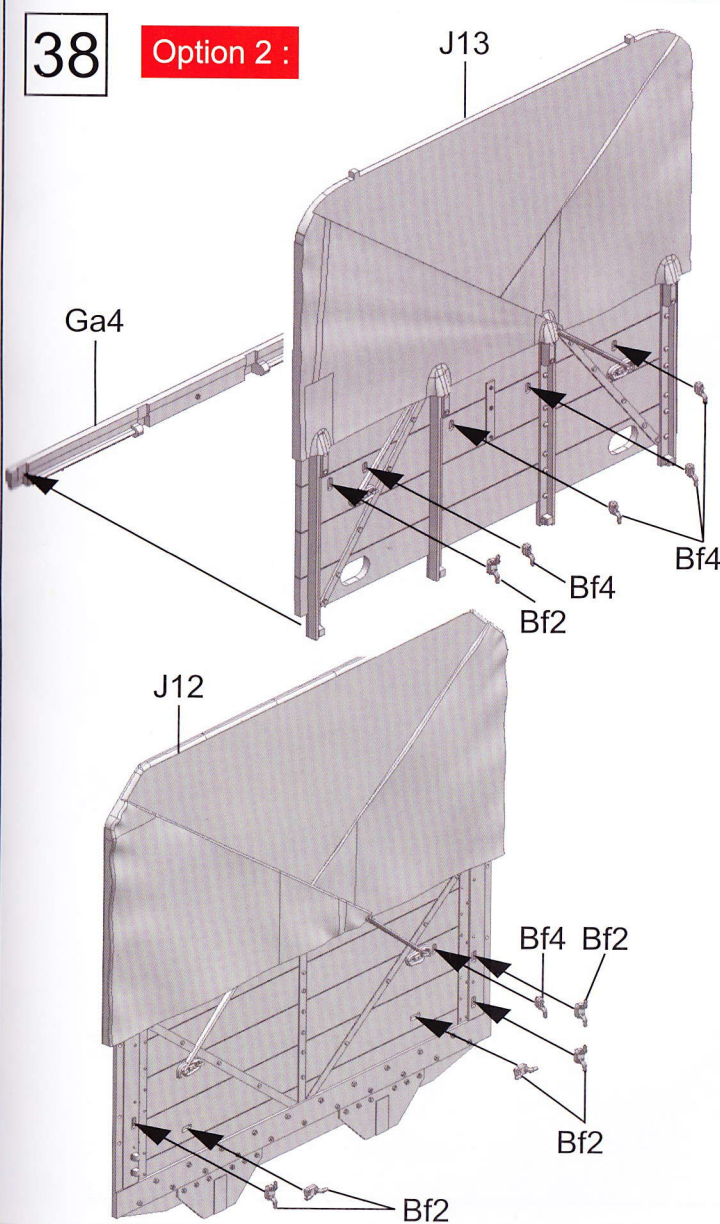
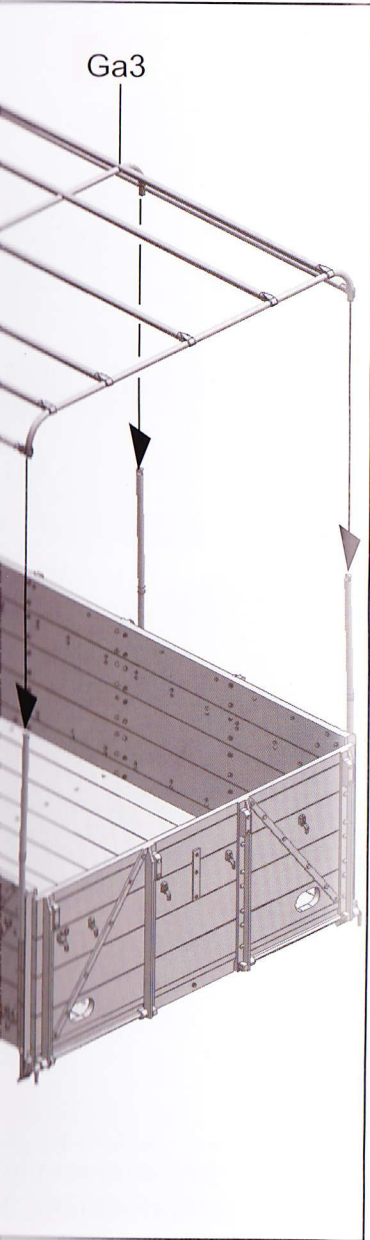



40

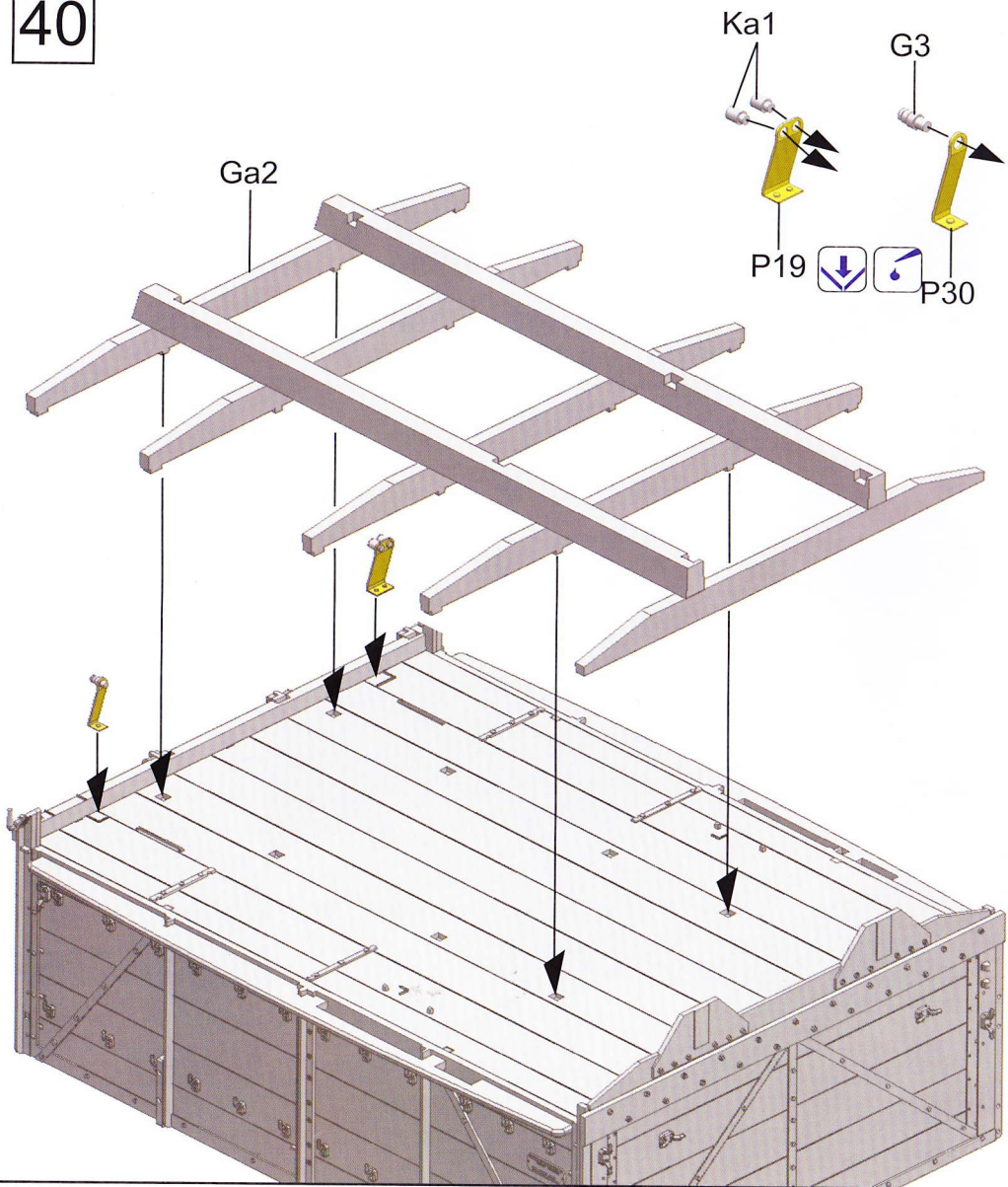

28

39

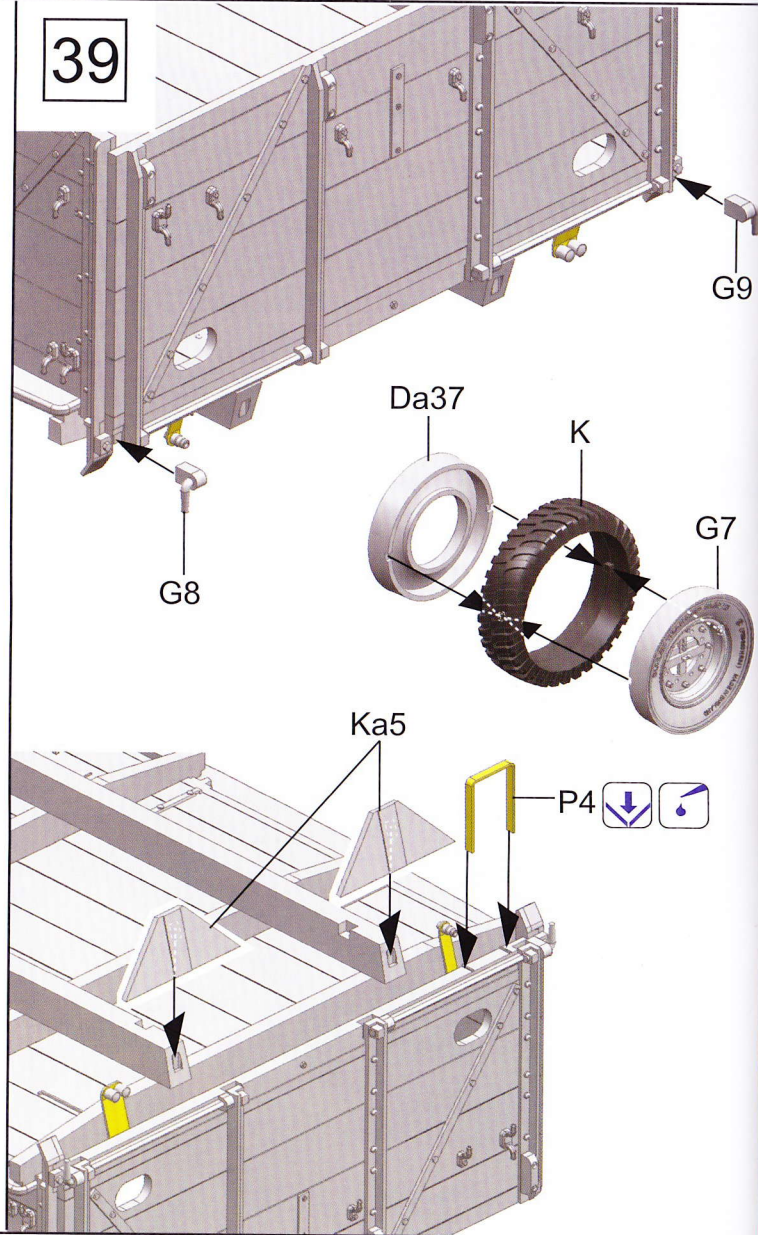

41

Option 1 :

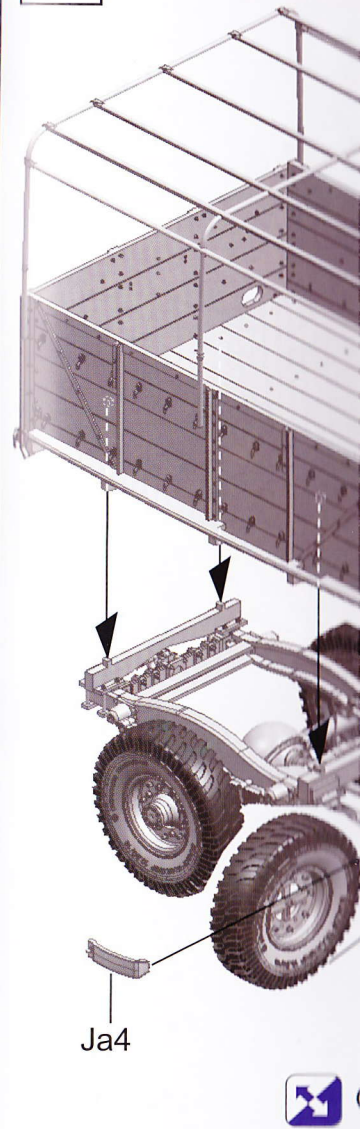



41

Option 1 :

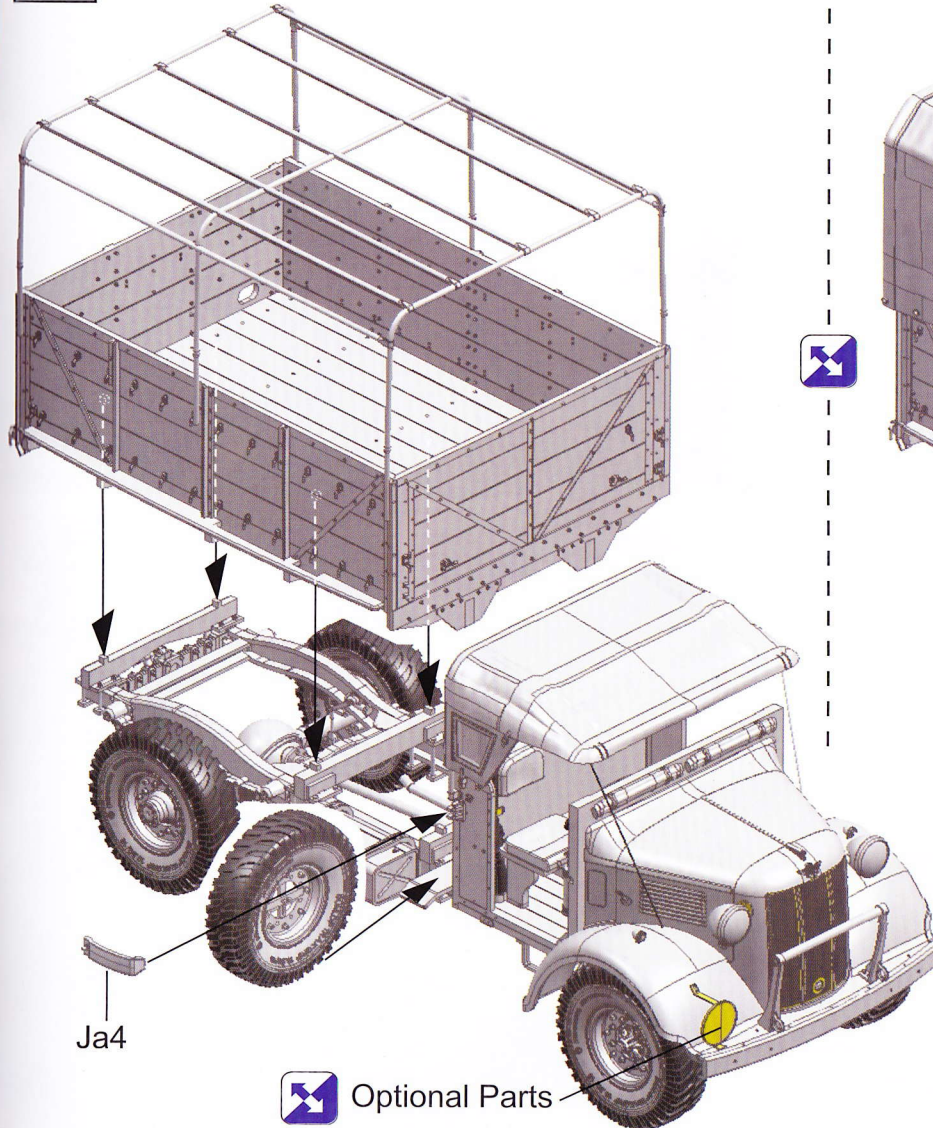

 Optional Parts

Option 2 :

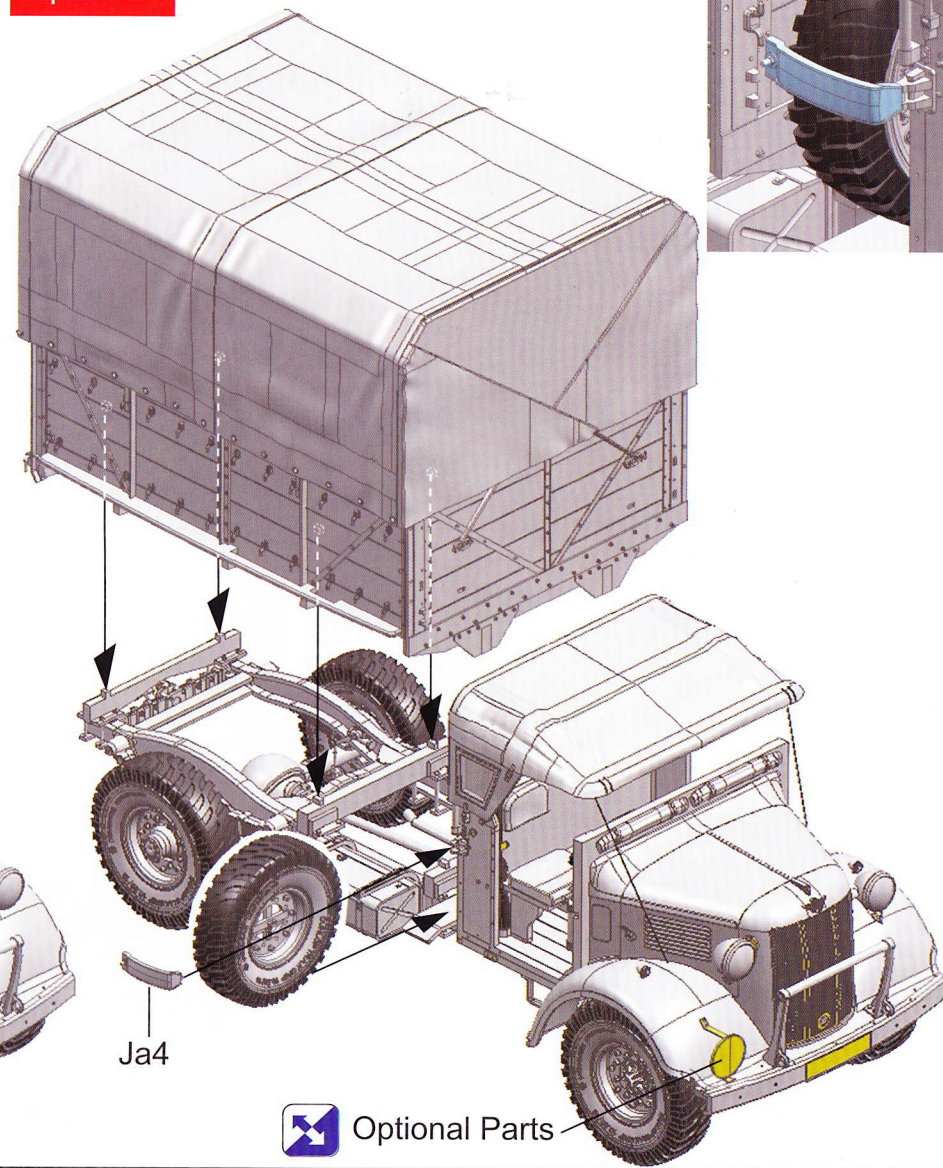

 Optional Parts

42

m

German Version only

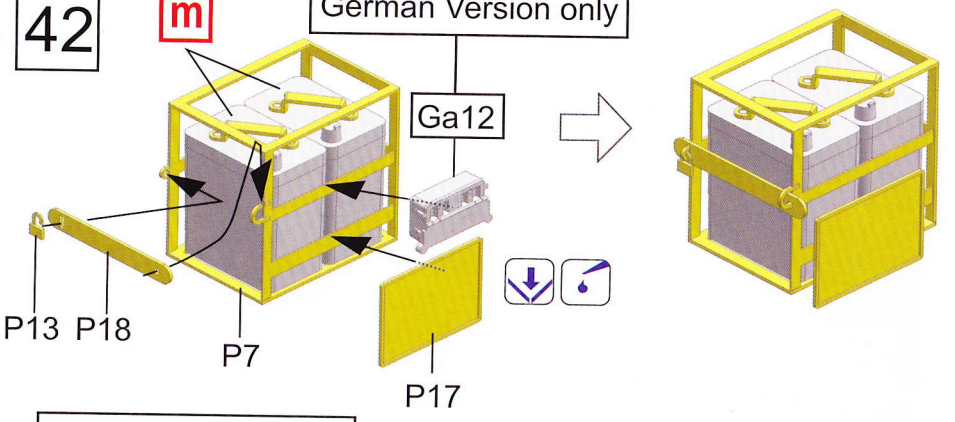

German Version only

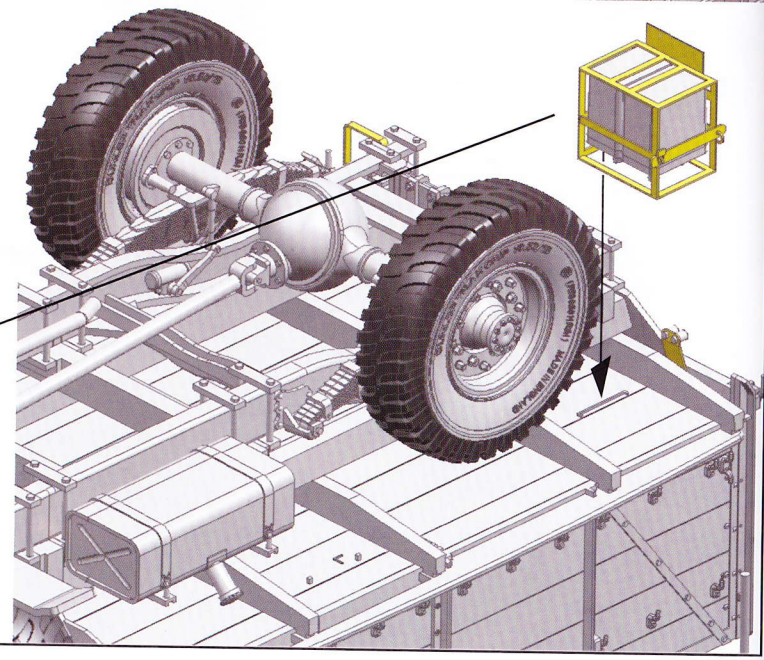
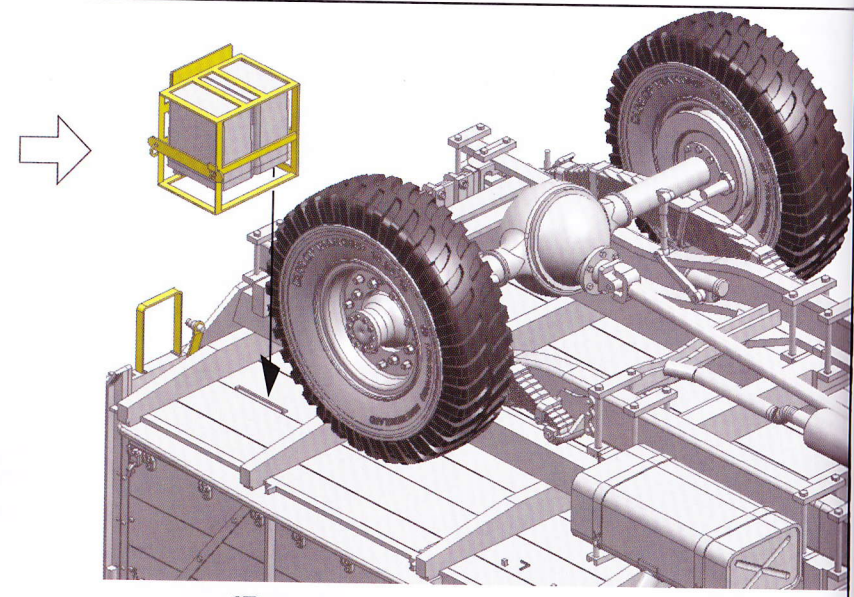
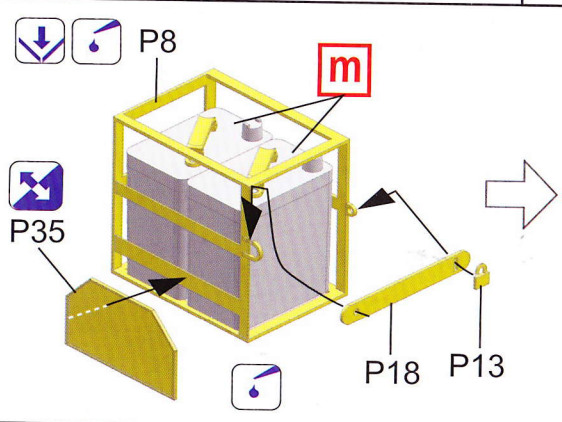
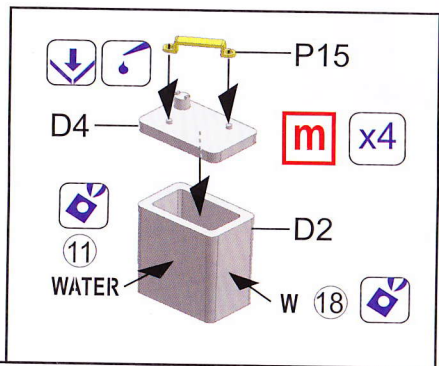
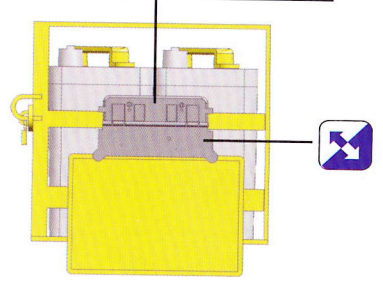

43

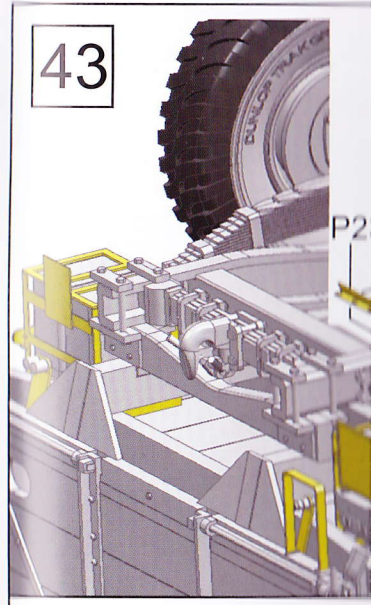

44

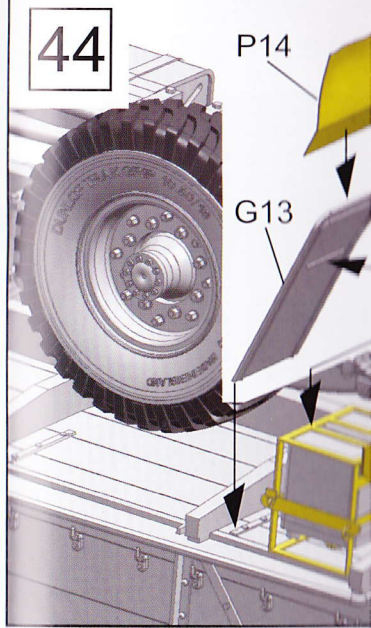

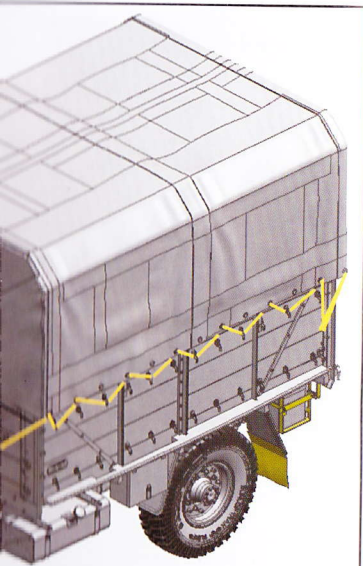

ing:0.5mmX20mmX2

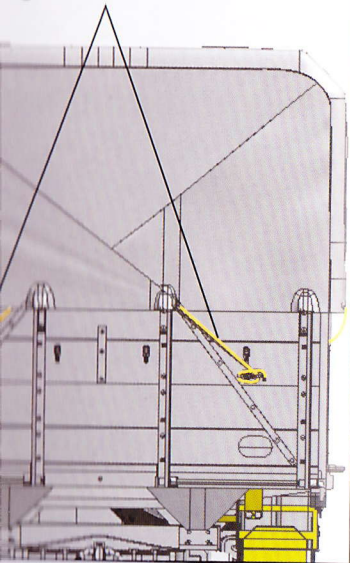

Option 1: II Corps, 33rd Section, 2nd Personnel Company, Royal Army Service Corps, Dunkirk, May 1940.

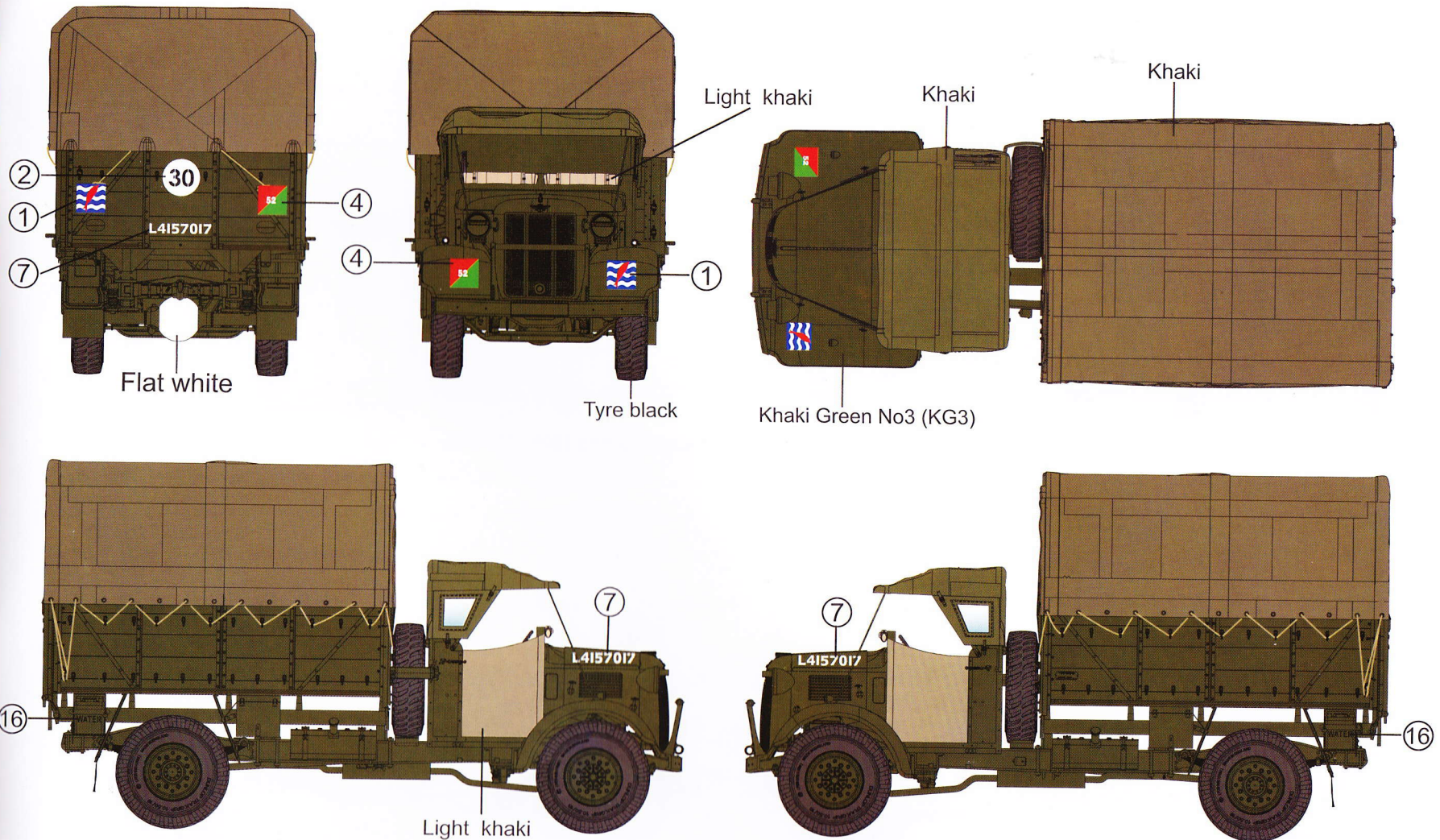

Option 2: 1st Btn, Royal Fusiliers, 5th Indian Infantry Brigade, 4th Indian Infantry Division, Western Desert Force, August 1941.

Option 3: K30 Butew

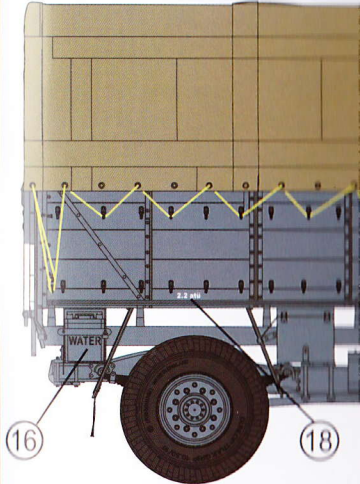
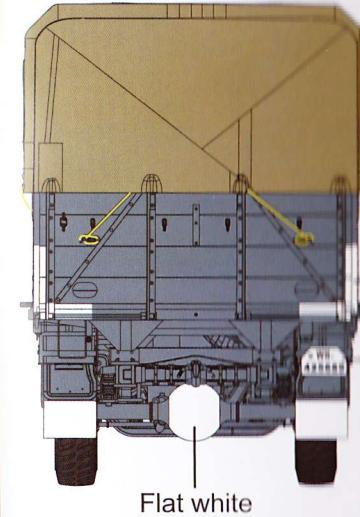
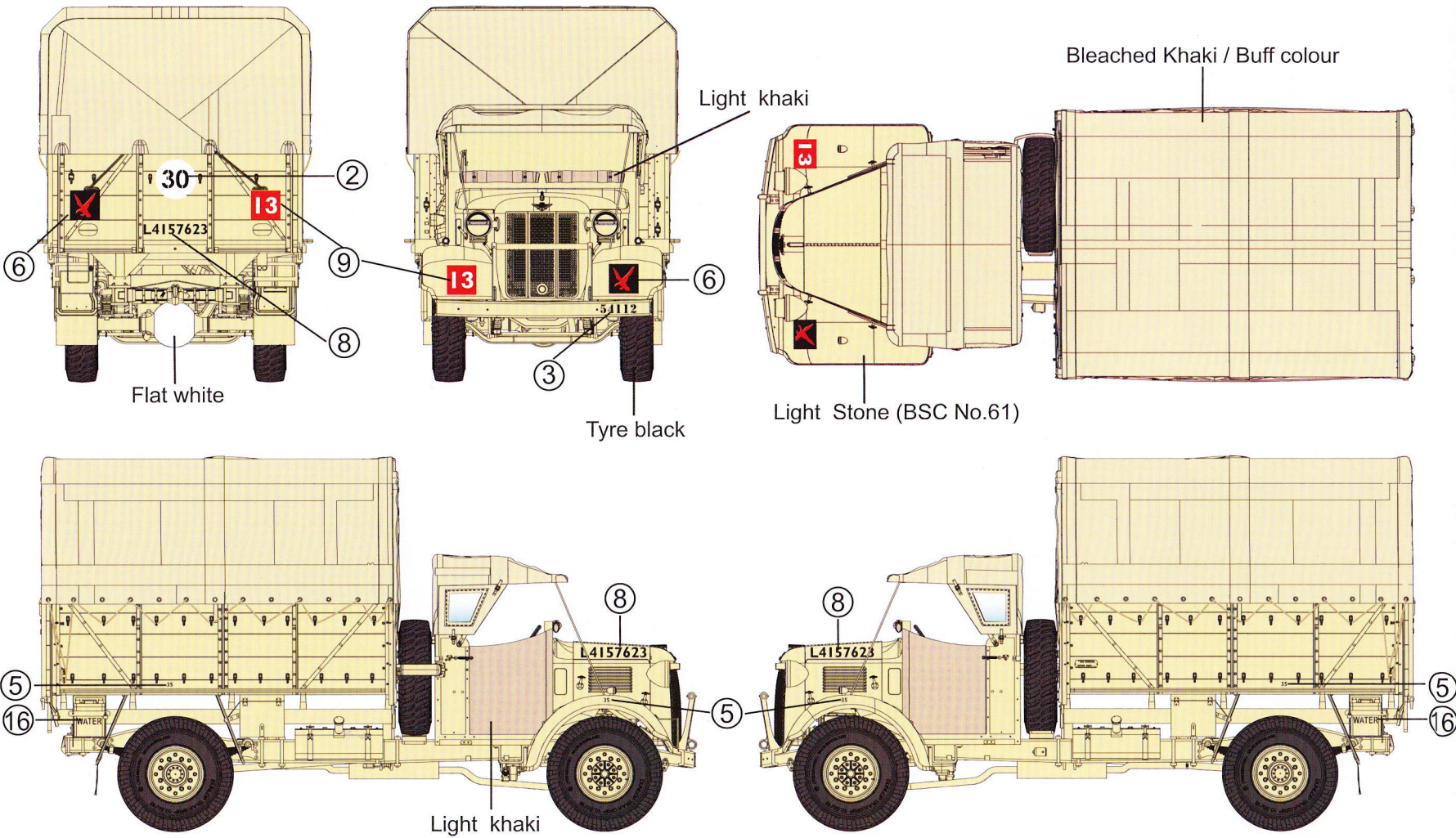

Western Desert Force,

Khaki / Buff colour

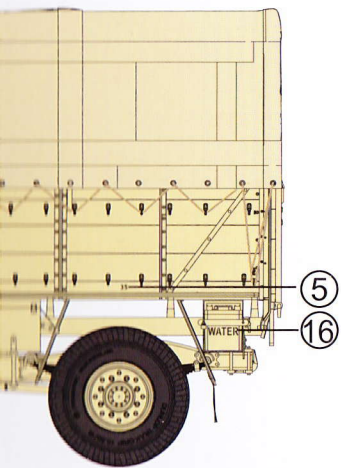
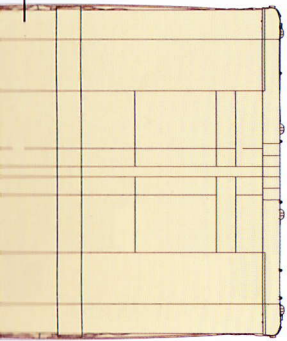

Option 3: K30 Beutewagen, Wehrmacht Heer, Operation Barbarossa, USSR, August 1941.

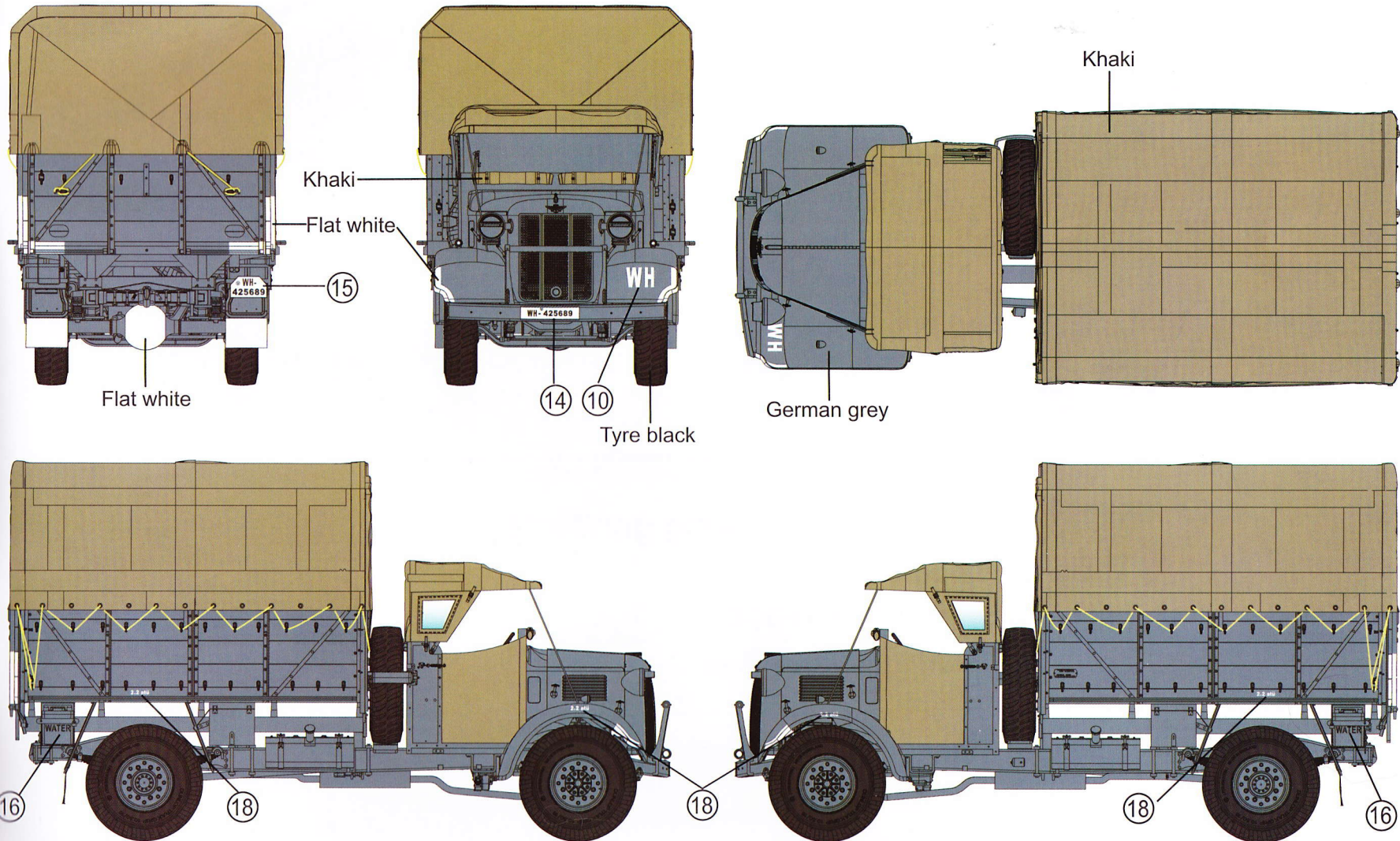

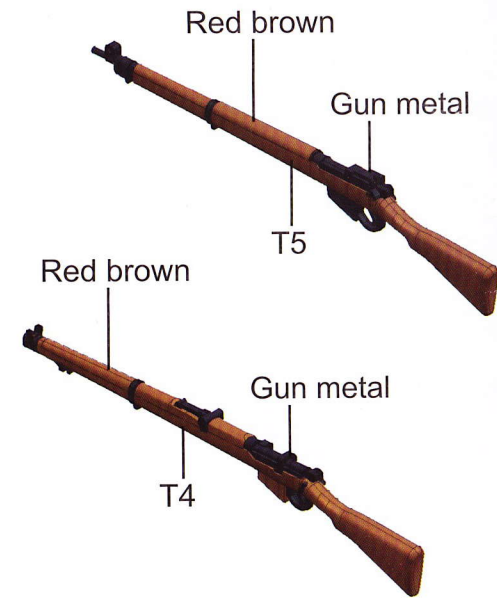
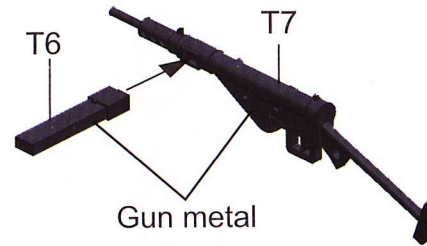
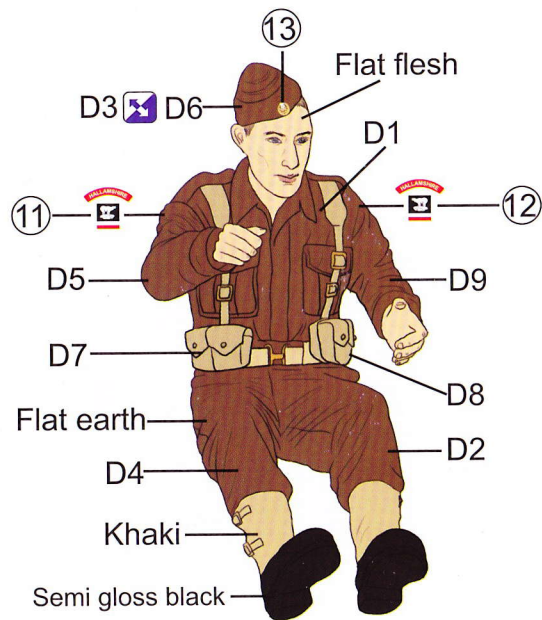

\*Many thanks to the following gentlemen for their assistance.  
 They are: - Simon King  
 Andrew Gadd  
 Kurtis Tsang

